

**1.1 Experimental design**

**1.2 Methods of purification and analysis**

**1.3 Identification of ions and gases**

- 1 A gas is less dense than air and dissolves in water.

Which diagram shows the correct method of collecting this gas?

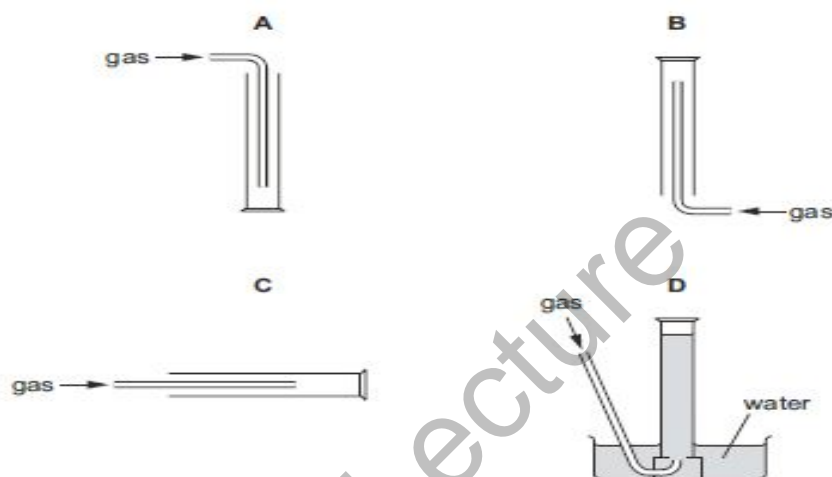

- 2 Which mixture can be separated into its components by adding water, stirring and filtering?

- A calcium carbonate and sodium chloride
- B magnesium and iron
- C sodium chloride and copper(II) sulfate
- D sulfuric acid and hydrochloric acid

- 3 Tests were carried out on an aqueous solution of an unknown compound, P. The observations are recorded in the table.

test	observation
aqueous sodium hydroxide added	green precipitate, soluble in excess giving a green solution
dilute nitric acid added then aqueous barium nitrate	white precipitate
dilute nitric acid added then aqueous silver nitrate	no precipitate

Which ions are present in P?

- A  $\text{Cr}^{3+}$  and  $\text{Cl}^-$
- B  $\text{Cr}^{3+}$  and  $\text{SO}_4^{2-}$
- C  $\text{Fe}^{2+}$  and  $\text{Cl}^-$
- D  $\text{Fe}^{2+}$  and  $\text{SO}_4^{2-}$

**Experimental Chemistry MCQS**

**Compiled by Mustafa Asif**

- 4 A student wants to show that the rate of the reaction between calcium carbonate and dilute hydrochloric acid doubles for every 10 °C rise in temperature.

The method the student uses is to measure the volume of carbon dioxide released.

The student has a Bunsen burner and a gas syringe.

What other essential apparatus must the student use?

- A balance, burette, pipette, measuring cylinder
  - B balance, measuring cylinder, clock, thermometer
  - C burette, pipette, clock, thermometer
  - D pipette, measuring cylinder, clock, thermometer
- 5 Which row gives the correct tests to identify both ammonia and sulfur dioxide?

	test to identify ammonia	test to identify sulfur dioxide
A	damp blue litmus paper	acidified potassium manganate(VII)
B	damp blue litmus paper	damp red litmus paper
C	damp red litmus paper	acidified potassium manganate(VII)
D	damp red litmus paper	damp blue litmus paper

- 6 A student titrates aqueous sodium hydroxide from a burette with dilute hydrochloric acid in a conical flask.

After the titration is complete, the conical flask is emptied.

What is the correct procedure before the next titration?

- A Rinse out the conical flask with aqueous sodium hydroxide.
  - B Rinse out the conical flask with dilute hydrochloric acid.
  - C Rinse out the conical flask with distilled water.
  - D Use the conical flask again without rinsing.
- 7 The results of a paper chromatography experiment are shown.

X is an aqueous solution of a salt of a Group I element.

Y is an aqueous solution of a salt of a transition element.

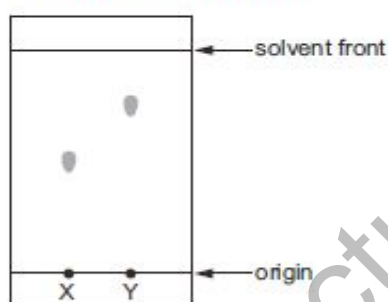

Which row is correct?

	larger $R_f$ value	requires a locating agent
A	X	X
B	X	Y
C	Y	X
D	Y	Y

- 8 A substance dissolves in water to form a colourless solution. This solution reacts with aqueous silver nitrate in the presence of dilute nitric acid to give a yellow precipitate.

What is the possible identity of the substance?

- A calcium iodide
- B copper(II) chloride
- C iron(II) iodide
- D sodium chloride

**Experimental Chemistry MCQS**

**Compiled by Mustafa Asif**

- 9 When heated, magnesium reacts with oxygen in the air to form magnesium oxide, a white powder.

A student investigates the change in mass that occurs during this reaction. He is given a balance and the three sets of apparatus shown.

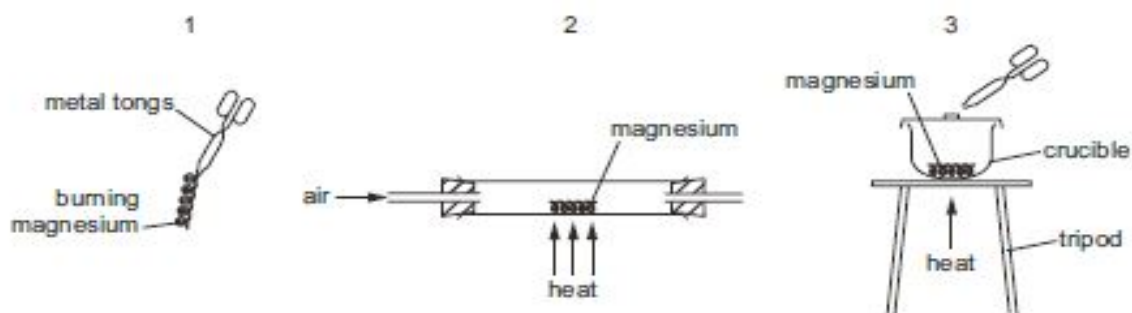

Which sets of apparatus are suitable for this investigation?

- A 1, 2 and 3    B 1 and 3 only    C 2 and 3 only    D 2 only
- 10 Four substances are heated gently. The temperatures at which they start and finish melting are recorded.

substance	temperature	
	start melting /°C	finish melting /°C
1	117	117
2	0	0
3	38	40
4	101	105

Which statement about the substances is correct?

- A Substance 1 is the only pure substance.  
 B Substance 3 and substance 4 are impure.  
 C Substance 4 is water.  
 D They are all solids at room temperature.
- 11 The results of two tests on solution X are shown.

reagent added	observation on adding a few drops of reagent	observation on adding an excess of reagent
aqueous sodium hydroxide	white precipitate	precipitate dissolves
aqueous ammonia	white precipitate	precipitate remains

Which ion is present in solution X?

- A  $Al^{3+}$     B  $Ca^{2+}$     C  $Cu^{2+}$     D  $Zn^{2+}$

**Experimental Chemistry MCQS**

**Compiled by Mustafa Asif**

- 12 A student follows the rate of the reaction between marble chips,  $\text{CaCO}_3$ , and dilute hydrochloric acid.

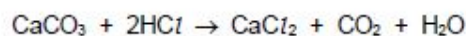

Which diagrams show apparatus that is suitable for this experiment?

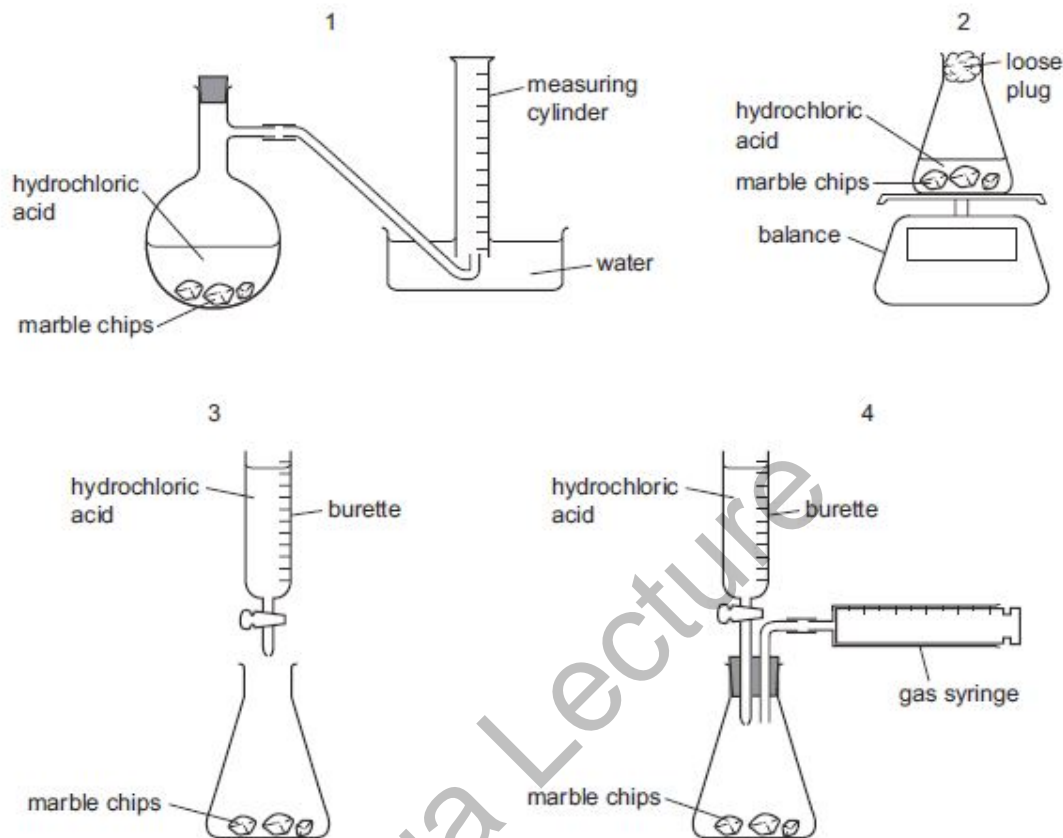

- A 1 and 2 only    B 1 and 3    C 1 and 4 only    D 1, 2 and 4

- 13 A mixture of sand and sodium chloride can be separated in three steps.

Step 1 is to add water to the mixture.

The diagram shows step 2 and step 3.

Where is pure sodium chloride collected?

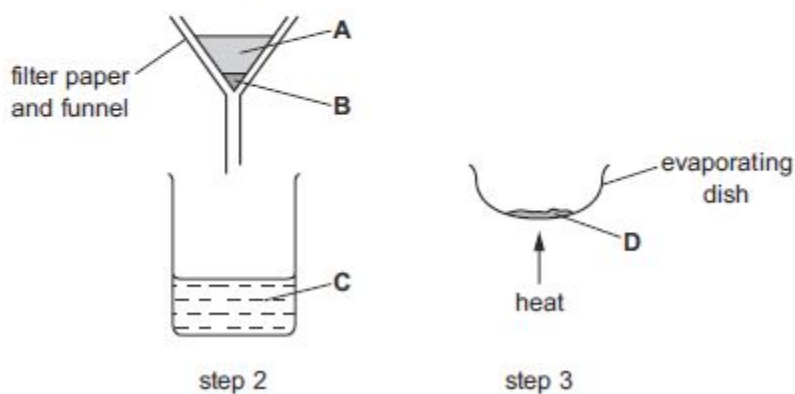

- 14 A chemist wishes to separate and identify a mixture of substances using paper chromatography. The diagram shows the apparatus used. The solvent is water.

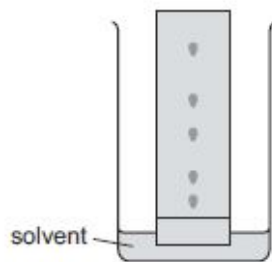

The solvent front is allowed to reach the top of the paper before the chemist removes the paper from the solvent.

Which problem does this cause?

- A This causes the spot nearest the bottom of the paper to catch up with the spot above it.
  - B This makes it impossible to calculate  $R_f$  values.
  - C This makes it impossible to use a locating agent.
  - D This results in a safety hazard caused by solvent fumes.
- 15 Gas X has the following properties.
- 1 colourless
  - 2 no effect on either red or blue litmus papers
  - 3 no effect on limewater
  - 4 flammable

What is gas X?

- A ammonia
  - B chlorine
  - C hydrogen
  - D oxygen
- 16 A gas is evolved during a reaction.
- Which two pieces of apparatus would enable the rate of this reaction to be measured?
- A balance and pipette
  - B gas syringe and thermometer
  - C stopclock and gas syringe
  - D stopclock and pipette

17 An aqueous solution of zinc chloride is tested by adding reagents.

Which observation is correct?

	reagent added to zinc chloride (aq)	observations
A	acidified aqueous barium nitrate	forms a white precipitate
B	aqueous ammonia	forms a white precipitate, soluble in excess of the reagent
C	aqueous sodium hydroxide	forms a white precipitate, insoluble in excess of the reagent
D	powdered copper	forms a grey precipitate

18 The diagram shows four pieces of apparatus that are used to measure the volume of a gas or liquid.

Which piece of apparatus should always be filled to the same level?

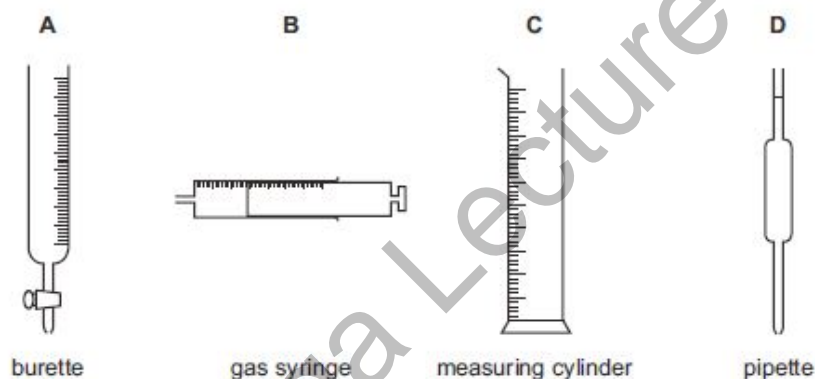

19 Four samples are spotted onto chromatography paper. It is known that one of these samples is pure compound Q. A separate sample of pure compound Q is also spotted onto the paper. The paper is placed in a solvent.

The diagram shows the chromatogram produced.

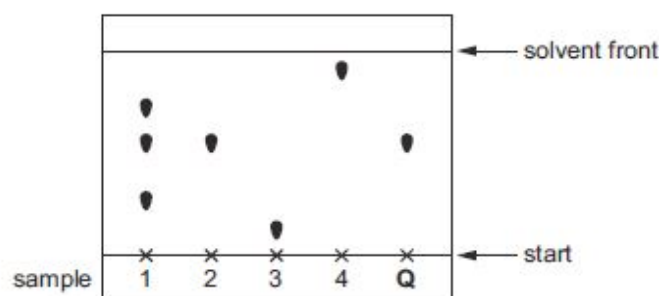

Which statement is correct?

- A Sample 2 has travelled the furthest and sample 3 is pure compound Q.
- B Sample 3 has travelled the furthest and sample 2 is pure compound Q.
- C Sample 4 has travelled the furthest and sample 1 is pure compound Q.
- D Sample 4 has travelled the furthest and sample 2 is pure compound Q.

20 The diagrams show four pieces of laboratory equipment.

balance

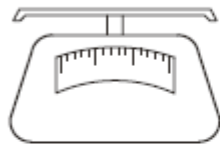

pipette



stop-clock



thermometer



Which equipment is essential to find out if dissolving a salt in water is an exothermic process?

	balance	pipette	stop-clock	thermometer
A	x	x	x	✓
B	✓	x	x	✓
C	x	✓	x	✓
D	✓	x	✓	x

21 Salt is added to pure water to form an aqueous solution.

Which statement is correct?

- A The melting point and the boiling point of the water both decrease.
- B The melting point and the boiling point of the water both increase.
- C The melting point of the water decreases but its boiling point increases.
- D The melting point of the water increases but its boiling point decreases.



- 22 A student uses the apparatus shown in the diagram below to measure the volume of carbon dioxide gas made when different masses of marble chips are added to 25 cm<sup>3</sup> of dilute hydrochloric acid.

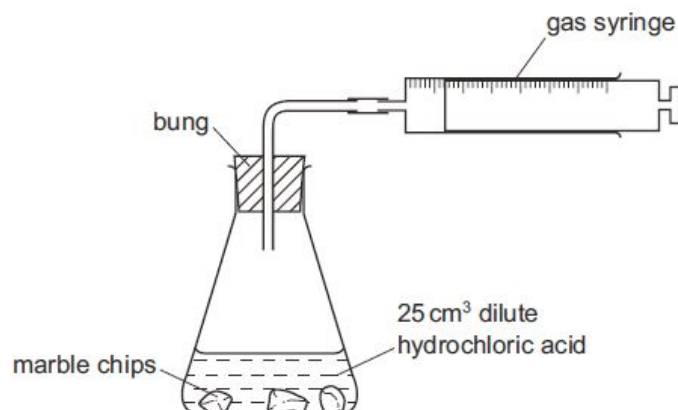

Which other items of apparatus are needed?

- A funnel and balance
  - B funnel and stopwatch
  - C measuring cylinder and balance
  - D measuring cylinder and stopwatch
- 23 A student is investigating a coloured mixture using chromatography.

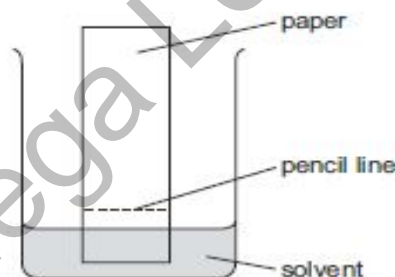

Where should the student place the coloured mixture?

- A in the solvent
- B just above the pencil line
- C just below the pencil line
- D on the pencil line

24 The diagrams show liquids in a burette and a measuring cylinder.

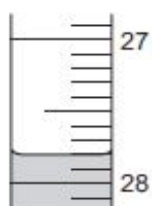

burette

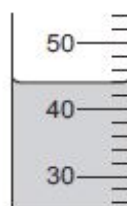

measuring cylinder

Which row shows the correct readings for the burette and the measuring cylinder?

	burette	measuring cylinder
<b>A</b>	27.8	42
<b>B</b>	27.8	44
<b>C</b>	28.2	42
<b>D</b>	28.2	44

25 Which piece of apparatus is used to measure exactly 26.3 cm<sup>3</sup> of a liquid?

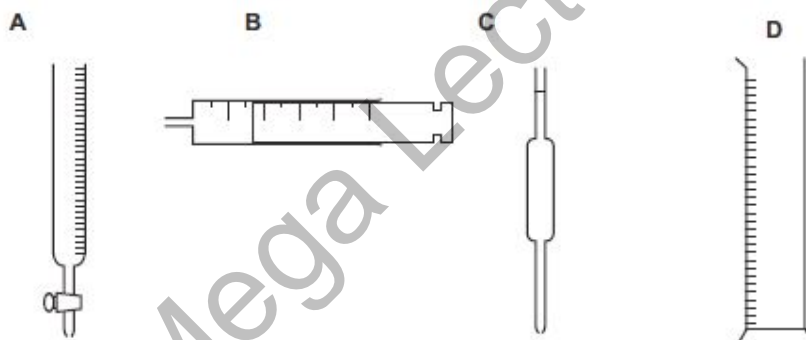

26 The melting points and boiling points of pure substances W, X and Y are shown.

	W	X	Y
melting point/°C	-114	115	-101
boiling point/°C	78	445	-34

The substances are chlorine, ethanol and sulfur.

Which row identifies W, X and Y?

	W	X	Y
<b>A</b>	chlorine	ethanol	sulfur
<b>B</b>	ethanol	sulfur	chlorine
<b>C</b>	sulfur	chlorine	ethanol
<b>D</b>	sulfur	ethanol	chlorine

27 Diagram 1 shows the paper chromatogram of substance X.

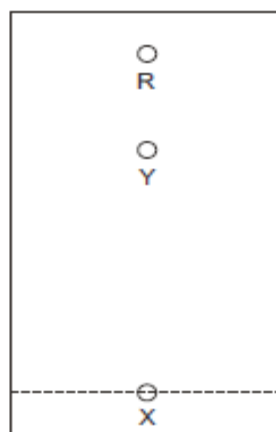

diagram 1

Diagram 2 shows the cooling curve for substance Y.

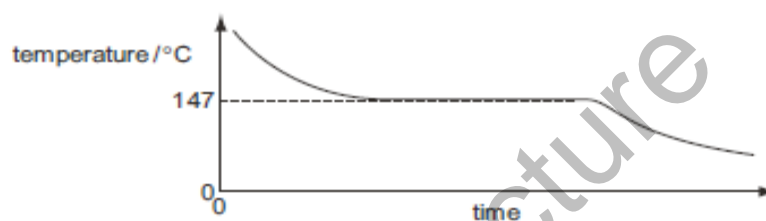

diagram 2

Which statement about X and Y is correct?

- A X is a mixture and Y is a pure substance.
- B X is a pure substance and Y is a mixture.
- C X and Y are mixtures.
- D X and Y are pure substances.

28 A solid mixture contains an ionic salt, X, and a covalent organic compound, Y.

Two students suggest methods of separating the mixture as shown.

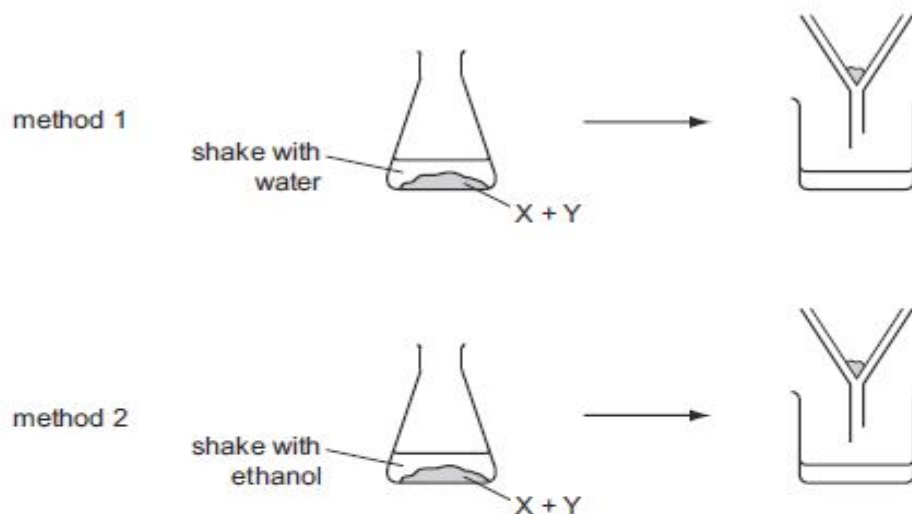

Which methods of separation are likely to work?

	1	2
<b>A</b>	✓	✓
<b>B</b>	✓	x
<b>C</b>	x	✓
<b>D</b>	x	x

29 Which method can be used to separate a mixture of salt and water to obtain both parts of the mixture?

- A crystallisation
- B distillation
- C evaporation
- D filtration

30 A student put 25.0 cm<sup>3</sup> of dilute hydrochloric acid into a conical flask.

The student added 2.5g of solid sodium carbonate and measured the change in temperature of the mixture.

Which apparatus does the student need to use to obtain the most accurate results?

- A balance, measuring cylinder, thermometer
- B balance, pipette, stopwatch
- C balance, pipette, thermometer
- D burette, pipette, thermometer

- 31 A mixture is separated using the apparatus shown.

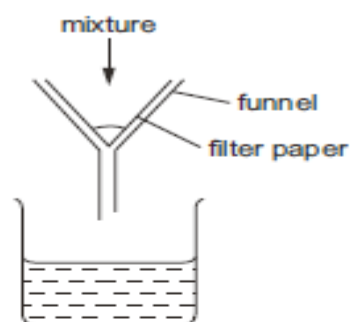

What is the mixture?

- A aqueous copper chloride and copper
  - B aqueous copper chloride and sodium chloride
  - C ethane and methane
  - D ethanol and water
- 32 Ethanol is made by fermentation.

How is ethanol obtained from the fermentation mixture?

- A chromatography
- B crystallisation
- C electrolysis
- D fractional distillation

33 Two experiments were carried out.

In experiment 1, ammonium carbonate was reacted with dilute hydrochloric acid.

In experiment 2, ammonium carbonate was heated with aqueous sodium hydroxide.

In each experiment, the gas evolved was tested with damp blue litmus paper and damp red litmus paper.

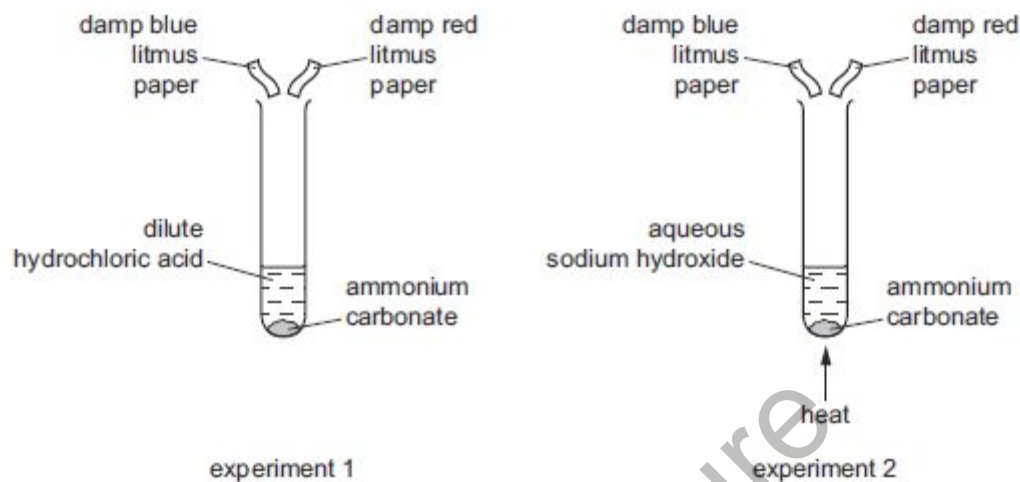

Which row correctly shows the colour of both the pieces of litmus paper at the end of each experiment?

	experiment 1	experiment 2
<b>A</b>	blue	blue
<b>B</b>	blue	red
<b>C</b>	red	blue
<b>D</b>	red	red

- 34 A paper chromatography experiment is carried out to find an  $R_f$  value for  $\text{Fe}^{3+}(\text{aq})$ . The result is shown.

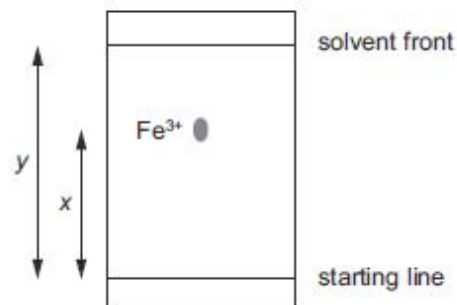

To make the spot containing  $\text{Fe}^{3+}(\text{aq})$  more visible, the paper is sprayed with aqueous sodium hydroxide so that a precipitate of iron(III) hydroxide forms.

Under the conditions of the experiment, the  $R_f$  of  $\text{Fe}^{3+}(\text{aq})$  is given by .....1..... and the colour of the precipitate is .....2.....

Which row correctly completes gaps 1 and 2?

	gap 1	gap 2
<b>A</b>	$\frac{x}{y}$	red-brown
<b>B</b>	$\frac{x}{y}$	green
<b>C</b>	$\frac{y}{x}$	red-brown
<b>D</b>	$\frac{y}{x}$	green

35 When calcium carbonate is added to dilute hydrochloric acid, carbon dioxide gas is released.

Three sets of apparatus are shown.

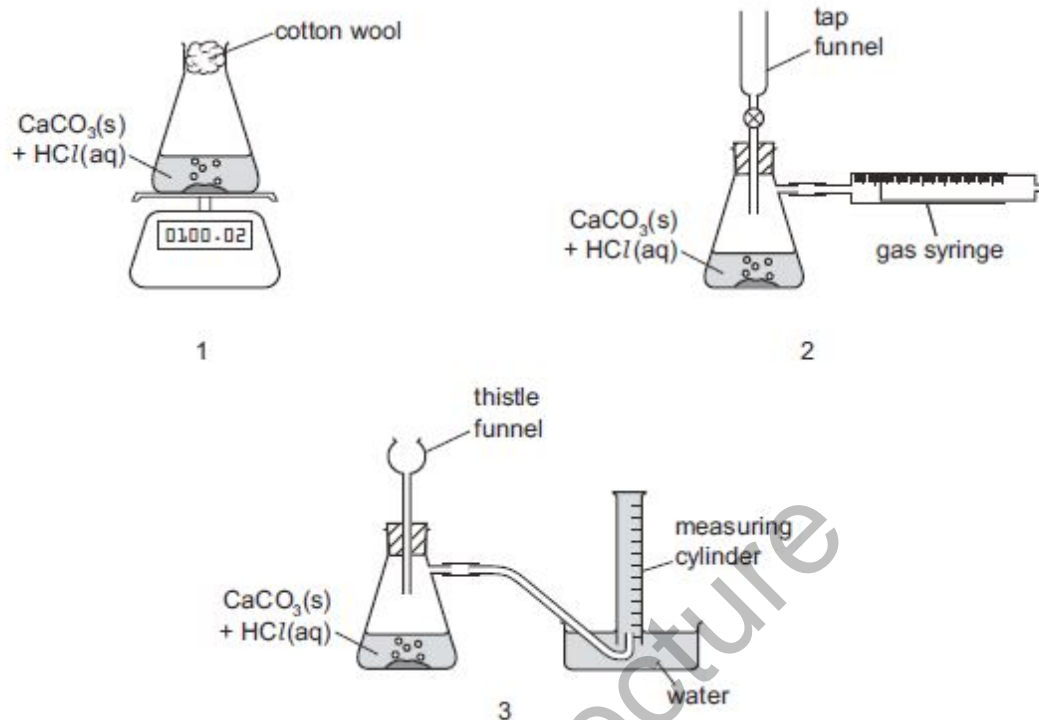

Which sets of apparatus are suitable, together with a stopwatch, for following the rate of this reaction?

- A 1, 2 and 3      B 1 and 2 only      C 2 only      D 2 and 3 only



36 The diagram shows the result of dropping a purple crystal into water.

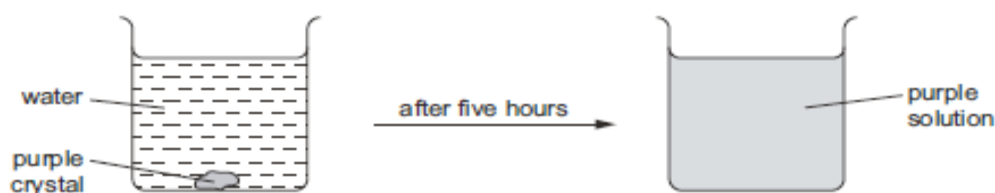

Which processes take place in this experiment?

	chemical reaction	diffusing	dissolving
<b>A</b>	✓	✓	✓
<b>B</b>	✓	x	✓
<b>C</b>	x	x	✓
<b>D</b>	x	✓	✓

37 Alcohol and water are completely miscible. This means when mixed together they form only one liquid layer.

Which method is used to separate alcohol from water?

- A** crystallisation
- B** filtration
- C** fractional distillation
- D** precipitation

38 The four pieces of apparatus shown below are used in chemical experiments.

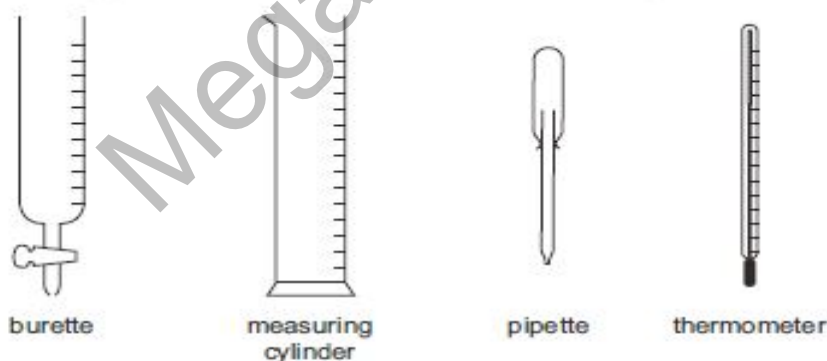

Which statement about the apparatus is correct?

- A** The burette measures the volume of liquid added in a titration.
- B** The measuring cylinder measures the mass of a substance used in an experiment.
- C** The pipette measures the volume of gas given off in a reaction.
- D** The thermometer measures the density of a solution.

**Experimental Chemistry MCQS**

**Compiled by Mustafa Asif**

- 39 Four gas jars each contain one of the gases ammonia, chlorine, hydrogen chloride and oxygen. A strip of damp blue litmus paper and a strip of damp red litmus paper are placed in each jar.

In which gas jar will both the damp blue litmus paper and the damp red litmus paper change colour?

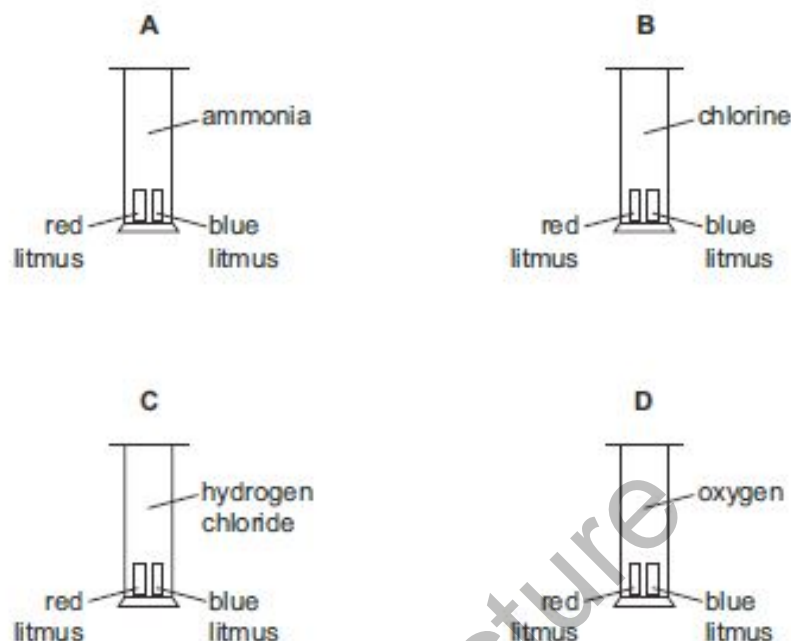

- 40 How can a pure sample of barium sulfate be obtained from barium carbonate?

- A Dissolve it in dilute hydrochloric acid, add dilute sulfuric acid, filter and crystallise.
- B Dissolve it in dilute hydrochloric acid, add dilute sulfuric acid, filter and wash.
- C Dissolve it in water, add dilute sulfuric acid, filter and crystallise.
- D Dissolve it in water, add dilute sulfuric acid, filter and wash.

41 Which row correctly identifies the gas?

	gas	test	observation
A	Cl <sub>2</sub>	damp litmus paper	the litmus paper turns blue
B	NH <sub>3</sub>	damp litmus paper	the litmus paper turns red
C	O <sub>2</sub>	limewater	no change is observed
D	SO <sub>2</sub>	acidified aqueous potassium manganate(VII)	the colour of the solution changes from purple to colourless

42 A student plans two experiments.

experiment 1 find the concentration of a solution of sodium hydroxide by titration with dilute hydrochloric acid

experiment 2 find the rate of the reaction between pieces of calcium carbonate and dilute hydrochloric acid by measuring the volume of gas given off every minute

A flask is provided.

Which other apparatus is needed?

	experiment 1	experiment 2
A	balance, measuring cylinder, thermometer	gas syringe, clock
B	burette, pipette	balance, measuring cylinder, thermometer
C	burette, pipette	gas syringe, clock
D	gas syringe, clock	burette, pipette

43 Q is a pure sample of a substance that has a single R<sub>f</sub> value of 0.9.

In the chromatogram shown, which letter represents Q?

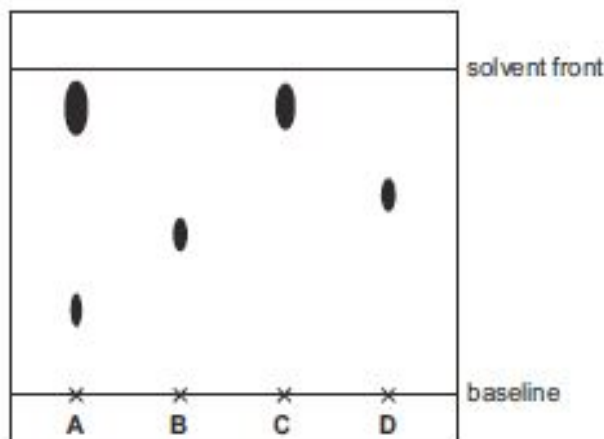

44 Which piece of apparatus is used to measure variable quantities of liquid in a titration?

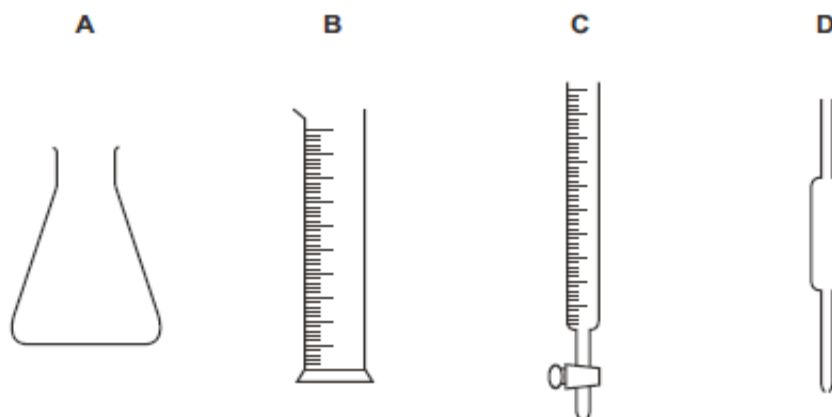

45 Which method separates a mixture of sugar and glass?

- A dissolve, filter and evaporate
- B distil and filter
- C fractionally distil
- D use chromatography

46 The diagram shows the fractional distillation of an aqueous solution of ethanol.

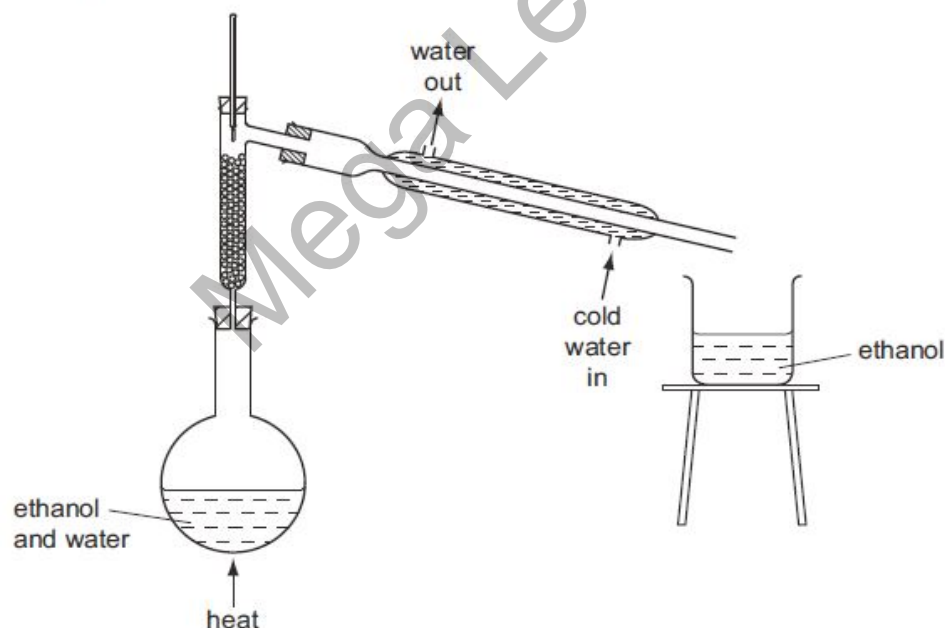

Which statement explains why ethanol is collected as the distillate?

- A Ethanol has a higher boiling point than water.
- B Ethanol has a higher melting point than water.
- C Ethanol has a lower boiling point than water.
- D Ethanol has a lower melting point than water.

- 47 In a titration between an acid (in the burette) and an alkali, you may need to re-use the same titration flask.

Which is the best procedure for rinsing the flask?

- A Rinse with distilled water and then with the alkali.
- B Rinse with tap water and then with distilled water.
- C Rinse with tap water and then with the acid.
- D Rinse with the alkali.

- 48 A colourless solution is known to contain a sodium salt.

Tests were carried out to determine the identity of the anion in the solution.

test	observation
dilute hydrochloric acid	no reaction
dilute nitric acid followed by aqueous silver nitrate	no precipitate
dilute nitric acid followed by aqueous barium nitrate	no precipitate

Which anion could the solution contain?

- A carbonate
- B chloride
- C nitrate
- D sulfate

For Live Classes, Recorded Lectures, Notes & Past Papers visit:

[www.megalecture.com](http://www.megalecture.com)

Experimental Chemistry MCQS

**Compiled by Mustafa Asif**

**Marking Key**

1.B	25.A
2.A	26.B
3.B	27.A
4.B	28.A
5.C	29.B
6.C	30.C
7.C	31.A
8.A	32.D
9.C	33.C
10.B	34.A
11. C	35.B
12.D	36.D
13.D	37.C
14.B	38.A
15.C	39.B
16.C	40.B
17.B	41.D
18.D	42.C
19.D	43.C
20.A	44.C
21.C	45.A
22.C	46.C
23.D	47.B
24.B	48.C

[FACEBOOK.COM/CAMBRIDGE O/A LEVEL AND IGCSE\(GROUP\)](https://www.facebook.com/CAMBRIDGE_O/A_LEVEL_AND_IGCSE(GROUP))

[youtube.com/c/MegaLecture/](https://www.youtube.com/c/MegaLecture/)

+92 336 7801123