

**0**  
**Level**

Classified ★ Topical ★  
**3** in **1**  
Yearly

# CHEMISTRY

## Topical Solved Paper-2





# CHEMISTRY PAPER 2

**Solved Topical and Yearly**

**(2005-2016)**

**Niaz Ahmed Awan**



9-F, Main Market Gulberg II, Lahore.  
Tel: 042-35714038 Cell: 0336-5314141  
E-mail: [readandwrite.publications@gmail.com](mailto:readandwrite.publications@gmail.com)  
Facebook page: [readandwritepublications/Shop](https://www.facebook.com/readandwritepublications/Shop)

*All rights reserved. No part of this publication may be reproduced, stored in a retrieval system or transmitted, in any form or by any means, electronic, mechanical, photocopying, recording or otherwise, without the prior written permission of the Publisher.*  
*Cambridge International has not provided these questions or answers and can take no responsibility whatsoever for their accuracy or suitability for the examinations.*

|                   |  |
|-------------------|--|
| Title             | <b>O-Level Chemistry P-2</b>   |
| Author            | Niaz Ahmed Awan<br>Cell: +92 300 425 5956<br>Email: niaz.awan564@gmail.com |
| Published by      | Read & Write Publications  |
| Printed by        | Sadaat Printers Urdu Bazar, Lahore.  |
| Composed by       | Rashid Mehmood, Salman Bukhsh  |
| Title designed by | Rashid Mehmood   |
| Edition           | 2016-17  |
| Price             | <b>Rs.500/-</b>  |

#### DISTRIBUTORS

| LAHORE   | KARACHI  |
|--|--|
| ➤ <b>BOOK WISE</b><br>12-Urdu Bazar, Lahore<br>Tel 042-37112265, 042-37361468              | ➤ <b>BURHANI BOOK CENTRE</b><br>Shop # 6 Hashmi Trust Building Rotson Road<br>New Urdu Bazar Karachi<br>Tel 021-32212640         |
| ➤ <b>BOOKLAND</b><br>16-Urdu Bazar, Lahore<br>Tel 042-37124656, 042-37223210               | ➤ <b>MARYAM ACADEMY</b><br>Mool Chand DiyaRaam Building Sindh Karachi.<br>Tel: 021-32214243 , 021-32634243                       |
| ➤ <b>NATIONAL BOOK SERVICE</b><br>22. Urdu bazar lahore.<br>Ph. 042-37247310, 042-37355262 |  |
|  | ISLAMABAD  |
|  | ➤ <b>BOOK VALLEY</b><br>Shop No. A-P-4, China market 5 Brothers Plaza College Road Rawalpindi<br>Tel: 051-35770894, 051-35551630 |

## Preface

This book has been developed as part of Read and Write Publications past papers solutions series. The book is organized as Solved/Topical/Yearly (3 in 1) series. It provides solutions for theory structured questions taken from past papers starting from June 2005 to June 2016.

Structure Questions testing knowledge of almost every area of the syllabus. This raises need of a solved topical book which could help the students to test their knowledge once they have learnt a particular syllabus area in the class.

This book includes Eleven units which are further divided into sub topics. Each question is labeled with exam year/paper/question no/section. e.g [J05/P2/QA1/d]. Each question is followed by SOLUTION section which provides brief yet comprehensive answers.

Index is added at the end to help reader search each question in chronicle order from 2005 to 2016 through page number given with each question.

Constructive criticism and suggestions to make the subsequent editions more useful would be appreciated and thankfully acknowledged.

Niaz Ahmed Awan  
Cell: +92 300 425 5956  
Email: [niaz.awan564@gmail.com](mailto:niaz.awan564@gmail.com)

## Contents

|               |   |            |
|---------------|---|------------|
| <b>Unit-1</b> | <b>Experimental Chemistry</b> .....                           | <b>6</b>   |
| 1.1           | Identification of Ions And Gases .....                        | 6          |
| 1.2           | Methods Of Separation (Purification) .....                    | 15         |
| <b>Unit-2</b> | <b>The Particulate Nature of Matter</b> .....                 | <b>18</b>  |
| 2.1           | Kinetic Particle Theory .....                                 | 18         |
| 2.2           | Atomic Structure .....  | 21         |
| 2.3           | Structures And Properties Of Materials .....                  | 31         |
| 2.4           | Ionic Bonding .....   | 40         |
| 2.5           | Covalent Bonding .....  | 47         |
| <b>Unit-3</b> | <b>Formulae, Stoichiometry And The Mole Concept</b> .....     | <b>52</b>  |
| <b>Unit-4</b> | <b>Electrolysis</b> .....                                     | <b>84</b>  |
| <b>Unit-5</b> | <b>Energy From Chemicals</b> .....                            | <b>100</b> |
| <b>Unit-6</b> | <b>Chemical Reactions</b> .....                               | <b>110</b> |
| 6.1           | Rate Of Reaction .....  | 110        |
| 6.2           | Redox .....   | 128        |
| 6.3           | Equilibrium & Dynamic Equilibrium .....                       | 135        |
| <b>Unit-7</b> | <b>The Chemistry and Uses of Acids, Bases and Salts</b> ..... | <b>139</b> |
| 7.1           | Properties Of Acids And Bases .....                           | 139        |
| 7.2           | Properties Of Salts .....                                     | 153        |
| 7.3           | Properties And Uses Of Ammonia .....                          | 157        |
| 7.4           | Sulfuric Acid .....   | 160        |
| <b>Unit-8</b> | <b>The Periodic Table</b> .....                               | <b>163</b> |
| 8.1           | Periodic Trends .....   | 163        |
| 8.2           | Group Properties .....  | 165        |
| 8.3           | Transition Elements .....                                     | 177        |
| <b>Unit-9</b> | <b>Metals</b> .....   | <b>181</b> |
| 9.1           | Properties of Metals .....                                    | 181        |
| 9.2           | Reactivity Series .....                                       | 186        |
| 9.3           | Extractions Of Metals .....                                   | 193        |
| 9.4           | Iron .....  | 194        |

|                |  |            |
|----------------|--|------------|
| 9.5            | Aluminium.....                         | 197        |
| <b>Unit-10</b> | <b>Atomsphere and Environment.....</b> | <b>199</b> |
| 10.1           | Air .....                              | 199        |
| 10.2           | Water .....                            | 202        |
| <b>Unit-11</b> | <b>Organic Chemistry.....</b>          | <b>219</b> |
| 11.1           | Alkanes.....                           | 219        |
| 11.2           | Alkenes.....                           | 227        |
| 11.3           | Alcohols.....                          | 238        |
| 11.4           | Carboxylic Acid.....                   | 247        |
| 11.5           | Macromolecules .....                   | 256        |
|                | Past papers.....                       | 269        |
|                | Index.....                             | Last page  |

Mega Lecture

## UNIT-1 EXPERIMENTAL CHEMISTRY

### 1.1 Identification of Ions And Gases

#### 1 [J05/P2/QA1/d]

(d) is an insoluble yellow solid. [1]

#### SOLUTION

(d) Lead (II) iodide

#### 2 [J05/P2/QA5/b]

(b) Describe a chemical test for each of the gases produced during the electrolysis of concentrated aqueous sodium chloride. [2]  
(i) chlorine  
(ii) hydrogen

#### SOLUTION

(b) (i) Chlorine turns damp blue litmus red and then bleaches it  
(ii) Hydrogen produces a pop sound with a burning splint

#### 3 [J06/P2/QA1/e]

Choose from the following elements to answer the questions below.

aluminium      argon      iron      nickel  
   phosphorus      sodium      nitrogen

Each element can be used once, more than once or not at all.

Name an element which

(e) Reacts with chlorine to form a solid that dissolves in water to give a coloured solution. [1]

#### SOLUTION

(e) Iron/Nickel  
(Being transition metals, they form coloured compounds)

#### 4 [J06/P2/QB8/c]

(c) (i) Describe a chemical test to show the presence of the nitrate ion. [2]  
(ii) Suggest why it might be difficult to test for the presence of the nitrate ion in a sample of river water. [1]

#### SOLUTION

(c) (i) Add Al foil and NaOH to the sample and warm it gently. A gas ( $\text{NH}_3$ ) forms, which turns damp red litmus paper blue (Other possible test: Add concentrated  $\text{H}_2\text{SO}_4$  and  $\text{FeSO}_4$  to the sample, brown ring forms)  
(ii) Nitrate ions are too dilute in river water

**5** [J06/P2/QB10/b,c]

- (b) A sample of powdered brass is added to excess dilute nitric acid.  
The mixture is heated gently until all the brass reacts.  
The resulting solution, **A**, contains aqueous copper(II) ions and aqueous zinc ions.
- (i) Suggest the colour of solution **A**. [1]  
(ii) Describe and explain, with the aid of equations, what happens when aqueous sodium hydroxide is slowly added to solution **A**. [5]
- (c) Another sample of powdered brass is added to excess dilute hydrochloric acid.  
The mixture is heated and an aqueous solution of a compound **B** together with a solid **C** are formed.
- (i) Name both **B** and **C**. [2]  
(ii) Write an ionic equation for this reaction. [1]

**SOLUTION**

- (b) (i) Blue  
(ii) Blue precipitate of  $\text{Cu}(\text{OH})_2$  forms;  
$$\text{Cu}^{2+} + 2\text{OH}^- \rightarrow \text{Cu}(\text{OH})_2$$
  
White precipitate of  $\text{Zn}(\text{OH})_2$  also forms in the beginning by small addition of  $\text{NaOH}$ ;  
$$\text{Zn}^{2+} + 2\text{OH}^- \rightarrow \text{Zn}(\text{OH})_2$$
  
This white precipitate of  $\text{Zn}(\text{OH})_2$  is masked by the blue precipitate of  $\text{Cu}(\text{OH})_2$  but due to its presence the color of  $\text{Cu}(\text{OH})_2$  turns light blue. By further addition of  $\text{NaOH}$ , a part of the precipitates obtained disappears as the white precipitate of  $\text{Zn}(\text{OH})_2$  redissolves in an excess of  $\text{NaOH}$ .
- (c) (i) **B** is zinc chloride  
**C** is copper  
(*Zn being more reactive reacts with HCl*)  
(ii) 
$$\text{Zn} + 2\text{H}^+ \rightarrow \text{Zn}^{2+} + \text{H}_2$$

**6** [N06/P2/QA5/a(ii)]

The diagram shows the stages in water purification.

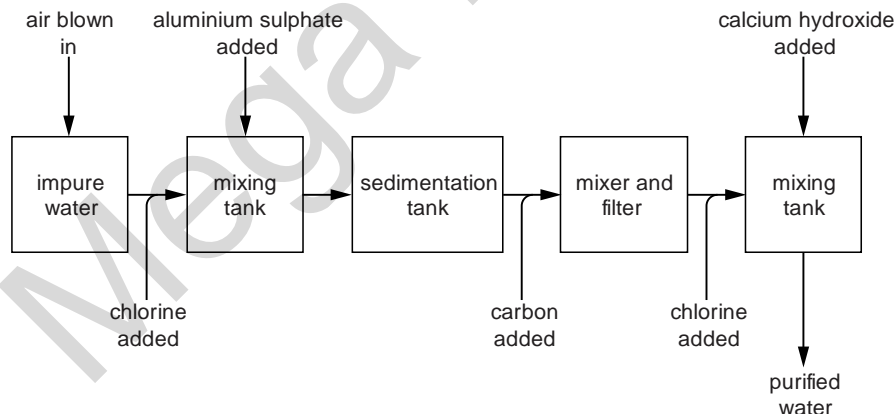

- (a) (ii) Describe a test for iron(III) ions.  
test  
result [2]



**SOLUTION**

- (a) (ii) **Test:** Add aqueous sodium hydroxide or aqueous ammonia  
**Result:** Red brown precipitate forms

**7** [J07/P2/QA2/b]

- (b) Aqueous iron(II) ions and aqueous iron(III) ions can be distinguished by reaction with aqueous sodium hydroxide. Describe what you would observe as a result of each reaction.  
observation with aqueous iron(II) ions [2]

**SOLUTION**

- (b) Observation with aqueous iron (II) ions:  
grey-green precipitate forms  
Observation with aqueous iron (III) ions:  
red-brown precipitate forms

**8** [J07/P2/QA7/a]

The carbonates of many metallic elements decompose when heated.

- (a) Name the gas produced during the decomposition of a metal carbonate and describe a chemical test for this gas.  
produced [2]

**SOLUTION**

- (a) Gas produced: Carbon dioxide  
Chemical test: It turns limewater milky  
(Metal carbonates decompose into metal oxides and CO<sub>2</sub>)

**9** [N07/P2/QA1/c]

- (c) produced when aqueous sodium nitrate is warmed with aqueous sodium hydroxide and aluminium foil, [1]

**SOLUTION**

- (c) Ammonia

**10** [N07/P2/QA3/d]

- (d) An aqueous solution of germanium(II) chloride reduces iron(III) ions to iron(II) ions. Describe a test for iron(II) ions and give the result.  
test  
result [2]

**SOLUTION**

- (d) **Test:** Add aqueous sodium hydroxide or aqueous ammonia  
**Result:** grey green precipitate forms.

**11** [N07/P2/QA6/d]

- (d) Sodium sulphate is often used in fireworks to give yellow sparks. Describe a test for sulphate ions and give the result.  
test  
result [2]

**SOLUTION**

- (d) **Test:** Add aqueous barium nitrate or lead nitrate;  
**Result:** White precipitate forms.

**12**

**[N07/P2/QB10/d]**

Soda-lime glass is made by heating a mixture of calcium carbonate, sodium carbonate and sand in a furnace to a high temperature.

Other glasses contain compounds called silicates. The simplified structures of a silicate and sodalime glass are shown.

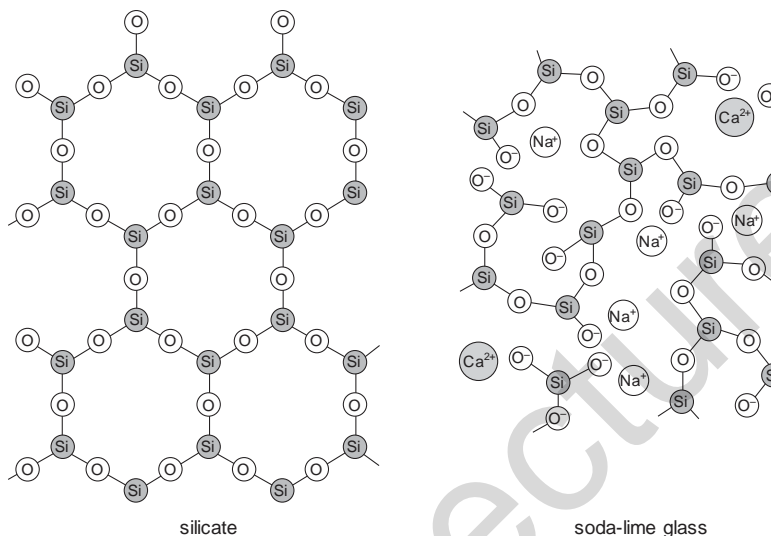

- (d) Some types of glass contain lead ions,  $Pb^{2+}$ .  
Dishwasher powders are highly alkaline.
- (i) Which ion is responsible for alkalinity? [1]
- (ii) When glasses containing lead ions are washed repeatedly in a dishwasher they go slightly white in colour.  
Suggest a chemical explanation for why the glass goes white. Write an equation for the reaction which occurs. [2]

**SOLUTION**

- (d) (i)  $OH^-$   
(ii) Lead ion reacts with alkaline soap to produce lead (ii) hydroxide which is white in color  
 $Pb^{2+} + 2OH^- \rightarrow Pb(OH)_2$ .

**13**

**[J08/P2/QA2/b,c]**

- (b) A sample of iron(II) sulphate is dissolved in water. Describe a test to show the presence of sulphate ions in this solution.  
reagents  
observation [2]
- (c) In the presence of aqueous hydrogen ions and dissolved oxygen, aqueous iron(II) ions are oxidised to form iron(III) ions and water.  
Write an ionic equation for this reaction. [2]

**SOLUTION**

- (b) **Reagents:** Barium nitrate + nitric acid  
(Other possible reagents: any soluble barium salt / lead nitrate salt + nitric / hydrochloric acid)  
**Observation:** White precipitate is formed chloride.

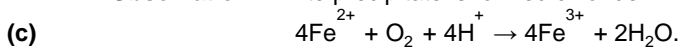

(In a balanced ionic equation, net charge on both sides must be equal; +12 in this case)

**14** [J08/P2/QB10/d]

- (d) Describe how aqueous ammonia can be used to show that only the zinc in the sample reacted with the acid. [3]

**SOLUTION**

- (d) The mixture obtained is filtered and aqueous ammonia is added to the filtrate. White precipitate is produced indicating the presence of  $\text{Zn}^{2+}$  ions. Blue precipitate is not formed indicating that  $\text{Cu}^{2+}$  ions are not present. This shows that the copper present in the alloy has not reacted with dilute HCl

**15** [N08/P2/QB10/b]

- (b) Name a reagent that reacts with iodide ions to form iodine molecules.  
Describe the colour change that occurs in this reaction. [2]

**SOLUTION**

- (b) Reagent: aqueous chlorine  
Color change: colorless to brown  
(Other possible reagents: aqueous bromine/nitric acid/potassium manganate/ potassium dichromate)

**16** [J09/P2/QA1/b]

- (b) Has an aqueous solution that reacts with aqueous sodium hydroxide to give a blue precipitate, [1]

**SOLUTION**

- (b) Copper (II) chloride  
( $\text{Cu}^{2+}$  ion reacts with NaOH to produce  $\text{Cu}(\text{OH})_2$  precipitate which is blue in color)

**17** [J09/P2/QA6/d,e]

- (d) Excess aqueous sodium hydroxide is added, a small volume at a time, to a sample of the aqueous industrial waste.  
Describe and explain what you would observe. [3]
- (e) Describe how you would confirm the presence of dissolved nitrate ions in the sample. [4]

**SOLUTION**

- (d) Grey-green precipitate of iron (II) hydroxide forms and white precipitate of calcium hydroxide forms which is masked by the grey green precipitate
- (e) Add excess sodium hydroxide followed by aluminium foil and heat the mixture. Ammonia is given off which turns moist red litmus paper blue indicating the presence of nitrate ions

**18** [N09/P2/QA1/a(ii)]

Choose from the following compounds to answer the questions below.

ammonium sulfate  
ethane

calcium oxide  
nitrogen dioxide

copper(II) chloride  
sodium iodide

ethanoic acid  
sulfur dioxide

Each compound can be used once, more than once or not at all.

Which compound

- (a) (ii) forms a yellow precipitate with aqueous silver nitrate, [1]

**SOLUTION**

- (a) (ii) Sodium iodide

**19** [N09/P2/QA5/b]

- (b) The bromine is purified by treatment with sulfur dioxide.  
Describe a test for sulfur dioxide. [2]

**SOLUTION**

- (b) **Test:** Take acidified potassium dichromate paper into the gas jar  
**Result:** Paper turns from orange to green  
(SO<sub>2</sub> is a reducing agent and can also be tested by using other colored oxidising agents such as KMnO<sub>4</sub>)

**20** [N10/P2/QA4/c(ii)]

- (c) (ii) Describe a positive test for iodide ions.  
test  
observation [2]

**SOLUTION**

- (c) (ii) **Test:** Add a few drops of dil nitric acid followed by aq. Lead II nitrate.  
**Observation:** A yellow ppt forms which is insoluble in excess ammonia.

**21** [N10/P2/QB7/d]

- (d) Describe a positive test for zinc ions.  
test  
observations [3]

**SOLUTION**

- (d) **Test:** Add aqueous sodium hydroxide  
**Observation:** white ppt forms which are soluble in excess NaOH

**22** [J11/P2/QA1/a,b,c]

Choose from the following compounds to answer the questions below.

|                    |                 |                      |                     |
|--------------------|-----------------|----------------------|---------------------|
| ammonia            | carbon monoxide | copper(II) carbonate | copper(II) chloride |
| copper(II) sulfate | sodium chloride | sodium hydroxide     | sodium sulfate      |
| sulfur dioxide     | sulfuric acid   | zinc carbonate       | zinc nitrate        |

Each compound can be used once, more than once or not at all.

Which compound

- (a) is a white solid with a high melting point that dissolves in water to form an alkaline solution, [1]  
(b) is a blue solid which, when dissolved in water, gives a white precipitate with aqueous barium nitrate, [1]  
(c) is a colourless gas that turns moist red litmus paper blue, [1]

**SOLUTION**

- (a) Sodium hydroxide  
NaOH is an ionic compound and hence has a high melting point

- All **compounds of sodium** are **soluble**  
NaOH produces **OH<sup>-</sup>** ion when dissolved in water and hence it is **alkaline**
- (b) Copper(II) sulfate  
**Copper compounds** are **blue/green** in color. With Barium nitrate they give a **white ppt** of **Barium sulfate**
- (c) Ammonia  
It is an **alkaline** gas

**23** [J11/P2/QB8/d]

- (d) Dilute hydrochloric acid reacts with aqueous silver nitrate to form a white precipitate.  
Write an ionic equation, with state symbols, for this reaction. [2]

**SOLUTION**

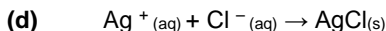

**24** [N11/P2/QA4/a(ii)]

Coal is largely carbon.

- (a) (ii) Give a test for carbon dioxide.  
test  
observation [2]

**SOLUTION**

- (a) (ii) **Test:** pass the gas through limewater  
**Observation:** Limewater turns milky

**25** [J12/P2/QA2/a,b]

Small pieces of a silver coloured metal, X, were added to concentrated nitric acid. A brown gas, Z, and a colourless solution containing salt Y were formed.

Analysis of a 0.0914 mol sample of Z showed it contained 1.28 g of nitrogen and 2.93 g of oxygen.

The small sample of the colourless solution was diluted with water and then divided into two portions.

- To one portion, aqueous sodium hydroxide was added drop by drop until it was in excess. A white precipitate, W, was formed that redissolved in the excess sodium hydroxide.
- To the other portion, aqueous ammonia was added drop by drop until it was in excess. A white precipitate, W, was formed that redissolved in the excess ammonia.

- (a) (i) Name the white precipitate, **W**. [1]  
(ii) Construct the ionic equation, with state symbols, for the formation of **W**. [2]

- (b) Name **X** and **Y**.  
**X** is  
**Y** is [2]

**SOLUTION**

- (a) (i) Zinc hydroxide  
(ii)  $\text{Zn}^{2+}_{(\text{aq})} + 2\text{OH}^-_{(\text{aq})} \rightarrow \text{Zn}(\text{OH})_{2(\text{s})}$
- (b) X- Zinc  
Y-Zinc nitrate

**26** [J13/P2/QA1/b]

Choose from the following elements to answer the questions below.

|               |                |                |               |               |                 |
|---------------|----------------|----------------|---------------|---------------|-----------------|
| <b>barium</b> | <b>calcium</b> | <b>carbon</b>  | <b>copper</b> | <b>helium</b> | <b>hydrogen</b> |
| <b>iron</b>   | <b>lead</b>    | <b>lithium</b> | <b>sulfur</b> | <b>zinc</b>   |                 |

Each element can be used once, more than once or not at all.

Name an element which

- (b) has an ion which, in aqueous solution, reacts with aqueous sodium hydroxide to give a green precipitate, [1]

**SOLUTION**

- (b) Iron II Hydroxide  
(Fe(OH)<sub>2</sub> is formed which has dirty green precipitate)

**27** [J13/P2/QA5/c]

- (c) Aqueous sodium hydroxide is added to solid X and the mixture is warmed.  
A colourless gas that turns moist red litmus blue is evolved.  
Deduce the formula of each of the two ions present in X. [2]

**SOLUTION**

- (c) NH<sub>4</sub><sup>+</sup> and NO<sub>3</sub><sup>-</sup>  
(NH<sub>4</sub><sup>+</sup> is alkaline and turns moist red litmus paper blue)

**28** [J13/P2/QB10/c(i)]

Solid sodium chloride and magnesium oxide have the same structure and bonding.  
This is the structure of sodium chloride.



The table shows the melting point of these two compounds.

| compound        | melting point / °C |
|-----------------|--------------------|
| magnesium oxide | 2852               |
| sodium chloride | 801                |

- (c) Sodium chloride is dissolved in distilled water.  
Excess aqueous silver nitrate is added to this solution and 0.232 g of a white precipitate is formed.  
(i) Construct an ionic equation, including state symbols, for the formation of the white precipitate. [2]

**SOLUTION**

- (c) (i)  $Ag^+(aq) + Cl^-(aq) \rightarrow AgCl(s)$

**29** [N13/P2/QB8/d]

- (d) An aqueous solution of hydrogen iodide contains iodide ions.  
Describe a test for iodide ions. [2]

**SOLUTION**

- (d) Add aqueous silver nitrate or lead nitrate, a yellow precipitate of AgI or PbI forms

30

[J14/P2/QA6]

The flow chart shows the reactions of metal **A** and some of its compounds.

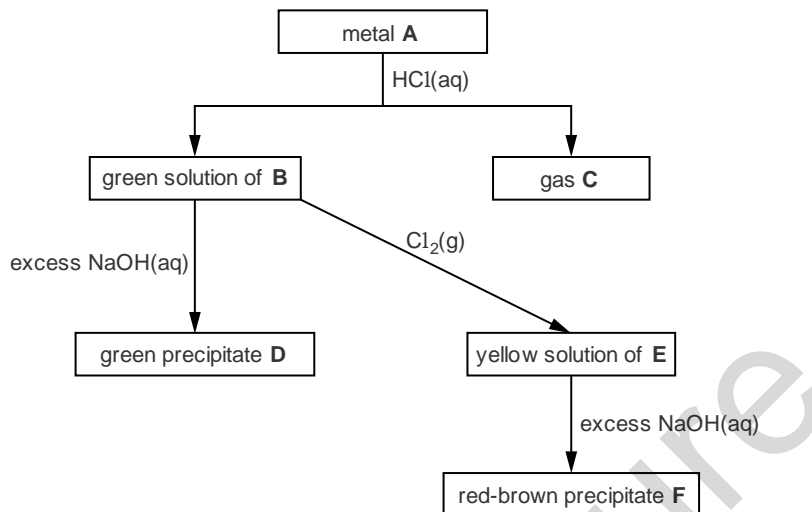

Identify, by name, each of the substances.

**A**    **B**    **C**    **D**    **E**    **F**

[6]

**SOLUTION**

- A**    Iron  
(Iron (II) compounds are green in color)
- B**    Iron(II) chloride  
( $\text{Fe} + 2\text{HCl} \rightarrow \text{FeCl}_2 + \text{H}_2$ )
- C**    Hydrogen  
( $\text{Fe} + 2\text{HCl} \rightarrow \text{FeCl}_2 + \text{H}_2$ )
- D**    Iron(II) hydroxide  
( $\text{FeCl}_2 + 2\text{NaOH} \rightarrow \text{Fe(OH)}_2 + 2\text{NaCl}$ )
- E**    Iron(III) chloride  
( $2\text{FeCl}_2 + \text{Cl}_2 \rightarrow 2\text{FeCl}_3$ )
- F**    Iron(III) hydroxide  
( $\text{FeCl}_3 + 3\text{NaOH} \rightarrow \text{Fe(OH)}_3 + 3\text{NaCl}$ )

31

[J14/P2/QB8/b]

(b) Describe the chemical test for hydrogen.

[1]

**SOLUTION**

(b) Hydrogen pops with a lighted splint.

32

[N14/P2/QA1/a(v)]

The diagram shows part of the Periodic Table. Only some of the elements are shown.

|  |  |  |  |  |  |  |  |  |  |  |  |  |  |  |  |  |  |  |  |  |  |
|--|--|--|--|--|--|--|--|--|--|--|--|--|--|--|--|--|--|--|--|--|--|
|  |  |  |  |  |  |  |  |  |  |  |  |  |  |  |  |  |  |  |  |  |  |
|  |  |  |  |  |  |  |  |  |  |  |  |  |  |  |  |  |  |  |  |  |  |
|  |  |  |  |  |  |  |  |  |  |  |  |  |  |  |  |  |  |  |  |  |  |
|  |  |  |  |  |  |  |  |  |  |  |  |  |  |  |  |  |  |  |  |  |  |
|  |  |  |  |  |  |  |  |  |  |  |  |  |  |  |  |  |  |  |  |  |  |
|  |  |  |  |  |  |  |  |  |  |  |  |  |  |  |  |  |  |  |  |  |  |
|  |  |  |  |  |  |  |  |  |  |  |  |  |  |  |  |  |  |  |  |  |  |
|  |  |  |  |  |  |  |  |  |  |  |  |  |  |  |  |  |  |  |  |  |  |
|  |  |  |  |  |  |  |  |  |  |  |  |  |  |  |  |  |  |  |  |  |  |
|  |  |  |  |  |  |  |  |  |  |  |  |  |  |  |  |  |  |  |  |  |  |
|  |  |  |  |  |  |  |  |  |  |  |  |  |  |  |  |  |  |  |  |  |  |
|  |  |  |  |  |  |  |  |  |  |  |  |  |  |  |  |  |  |  |  |  |  |

- (a) (v) as a chloride of type  $XC_3$  whose aqueous solution forms a reddish-brown precipitate on addition of aqueous ammonia, [1]

**SOLUTION**

- (a) (v) Iron (III) Hydroxide  
 ( $Fe(OH)_3$  is formed which has red-brown precipitate)

**1.2 Methods Of Separation (Purification)**

**33** [N07/P2/QA5/a]

Red grapes contain a number of coloured pigments. Some red grapes are crushed and the pigments extracted with a solvent. The deep red solution contains a mixture of pigments.

- (a) Name the technique used to separate the pigments in this mixture and draw a labeled diagram of the apparatus you would use. name of technique [3]

**SOLUTION**

- (a) Chromatography

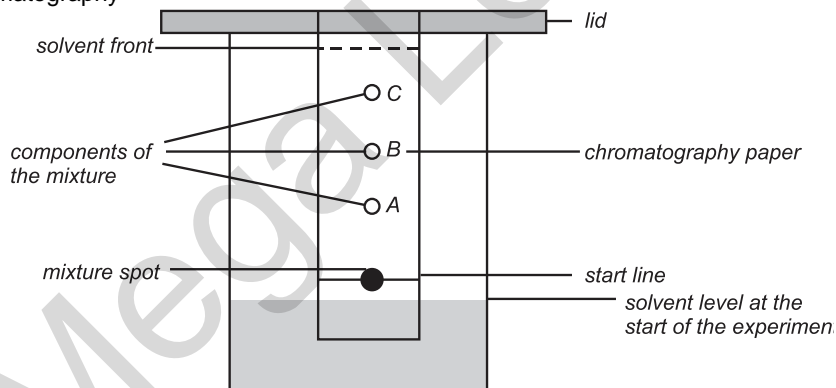

**34** [N08/P2/QB8/a]

Sorrel is a small green plant.

- (a) The pigments in the sorrel leaf can be separated by chromatography. (i) Describe how chromatography can be used to separate different pigments. [2]  
 (ii) Explain what is meant by  $R_f$  value. [1]



**SOLUTION**

- (a) (i) A dot of the mixture pigments is placed on a piece of filter paper marked with pencil line and the paper is then hung in the trough of solvent such that the dot does not immerse in the solvent. The solvent travels up the paper taking different components of the pigments to different heights, therefore separating them.
- (ii)  $R_f$  value refers to the ratio of the distance travelled by the pigment to the distance travelled by the solvent

$$R_f = \frac{\text{Distance travelled by the solute}}{\text{Distance travelled by the solvent}}$$

**35**

**[J14/P2/QA3/c]**

- (c) Proteins are hydrolysed to give a mixture of colourless amino acids. Describe, with the aid of a labelled diagram, how paper chromatography can be used to identify the amino acids present in a mixture of amino acids. [4]

**SOLUTION**

(c)

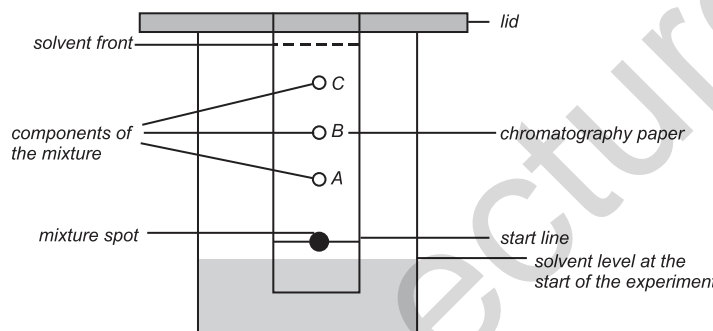

A dot of the mixture of colorless amino acids is placed on a piece of filter paper and the paper is hung in the trough of solvent such that the dot does not immerse in the solvent and the solvent just touches the lower end of the filter paper. The solvent travels up the paper taking different amino acids to different heights due to the difference of solubilities, therefore separating them. Filter paper is then removed from the jar, dried and sprayed with a locating agent such as ninhydrin to make the spots of separated amino acids visible.  $R_f$  values are then measured for each spot and compared with the known  $R_f$  values of amino acids.

**36**

**[N14/P2/QA3/a,b(i,iii)]**

Seawater contains a variety of dissolved salts.

- (a) The diagram shows a simple distillation apparatus that can be used to produce purified water from seawater.

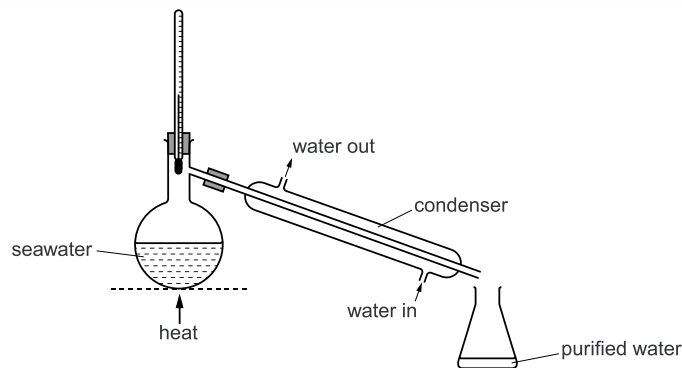

- Explain how distillation purifies seawater. [3]
- (b) (i) Write the formulae for the ions present in magnesium chloride. [1]
- (iii) Aqueous silver nitrate is added to a small sample of seawater. Describe what you would observe. [1]

**SOLUTION**

- (a) Water has much lower boiling point than dissolved salts and so it evaporates first when the heat energy is provided. Water vapours enter the condenser and condense to liquid form which is then collected in a beaker. The dissolved salts remain in the round-bottom flask.
- (b) (i)  $Mg^{2+}$  and  $Cl^-$
- (iii) White precipitate  
(White precipitate of  $AgCl$  forms when silver nitrate is added to seawater containing magnesium chloride)

## UNIT-2 THE PARTICULATE NATURE OF MATTER

### 2.1 Kinetic Particle Theory

1

[N07/P2/QA2]

A student set up the apparatus shown below.

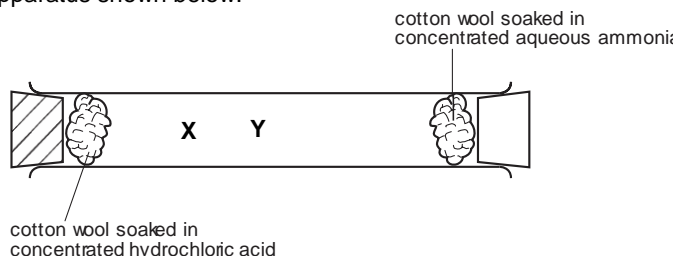

Colourless fumes of hydrogen chloride are given off by the hydrochloric acid.  
Colourless fumes of ammonia are given off by the aqueous ammonia.

- (a) After a few seconds, white fumes were seen at point X in the tube. Name the compound formed at point X. [1]
- (b) Use the kinetic particle theory to explain this observation. [3]
- (c) The student repeated the experiment using a solution of methylamine,  $\text{CH}_3\text{NH}_2$ , in place of ammonia,  $\text{NH}_3$ . The white fumes were seen at point Y in the tube, rather than at point X. Explain this difference. [2]

#### SOLUTION

- (a) Ammonium chloride ( $\text{NH}_3(\text{aq}) + \text{HCl}(\text{aq}) \rightarrow \text{NH}_4\text{Cl}(\text{aq})$ .)
- (b) The particles of HCl and  $\text{NH}_3$  diffuse from their respective cotton wools and collide at point X. HCl ( $M_r = 36.5$ ) being heavier, diffuses slower than  $\text{NH}_3$  ( $M_r = 17$ ) and that is why fumes produce closer to cotton wool soaked in HCl.
- (c) Methylamine ( $M_r = 31$ ) is heavier than ammonia and has a similar  $M_r$  to that of HCl, therefore it diffuses at similar rates to HCl and fumes are produced halfway at point Y.

2

[N09/P2/QA5/d]

- (d) Bromine is a liquid with a low boiling point and a strong smell. A technician spilt some bromine in the corner of a room which is free of draughts. After thirty seconds the bromine could be smelt on the other side of the room.

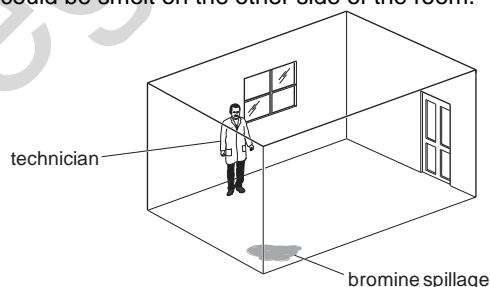

Fig. 2

Use the kinetic particle theory to explain why the bromine could be smelt on the otherside of the room. [3]

**SOLUTION**

- (d) Air molecules collide with liquid bromine molecules and transfer energy to bromine molecules. The bromine molecules which gather enough energy, change into vapors and move randomly through the air to reach the other corner of the room.

**3 [N11/P2/QA5/c(i,ii)]**

- (c) (i) Draw a diagram to show the arrangement of the molecules in liquid bromine.

Show a bromine molecule as .

- (ii) A small amount of liquid bromine was placed in the bottom of a sealed flask. After thirty minutes the brown colour of the bromine had spread throughout the flask.

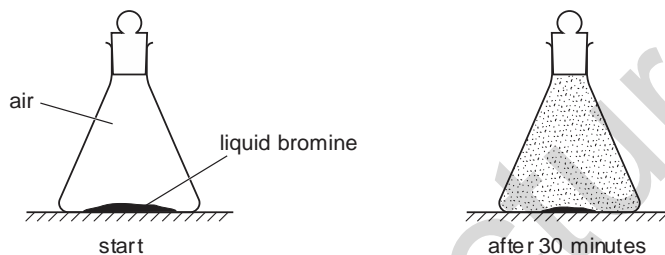

Use the kinetic particle theory to explain these observations. [3]

**SOLUTION**

- (c) (i)

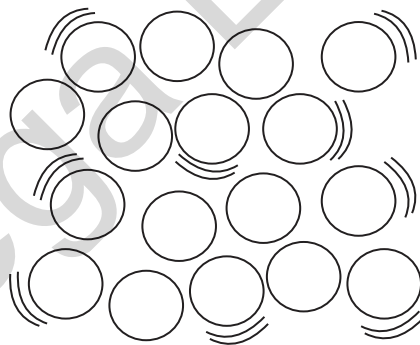

- (c) (ii) Higher energy bromine molecules escape from liquid and mix with air molecules. The liquid molecules move randomly diffusing into the air. After 30 minutes, liquid molecules diffuse completely giving a uniform brown colour.  
(Bromine molecules **move** from a region of **higher concentration** to a region of **lower concentration**, filling up the flask)

**4** [N12/P2/QB7(b)]

(b) Old wine glasses often appear cloudy because they have many small cracks on their surface.

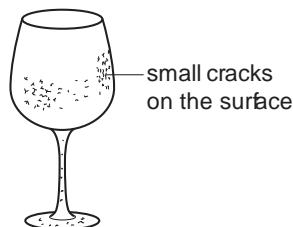

The cracks are caused by differences in the rate of diffusion of sodium ions and hydrogen ions in the glass.

- (i) Explain the meaning of the term *diffusion*. [1]  
 (ii) Suggest why sodium and hydrogen ions do not diffuse at the same rate. [1]

**SOLUTION**

- (b) (i) Diffusion refers to the random movement of particles in any direction  
 (ii) Hydrogen ion is lighter and smaller

**5** [J13/P2/QA3/b]

(b) At room temperature iodine is a solid and bromine is a liquid. Describe the difference between both the arrangement and the motion of particles in a solid and a liquid. [2]

**SOLUTION**

(b) In a solid, particles are regularly arranged and vibrate about their mean positions only. However, in a liquid, particles are irregularly arranged and move randomly, sliding over each other

**6** [N15/P2/QA5]

(a) Two students set up tubes as shown.

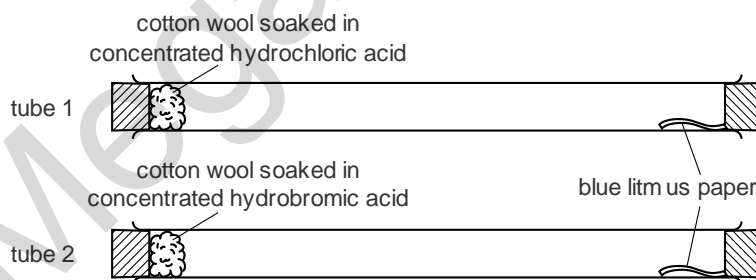

Concentrated hydrochloric acid produces fumes of hydrogen chloride.  
 Concentrated hydrobromic acid produces fumes of hydrogen bromide.  
 Four minutes after setting up the experiment, the litmus paper in tube 1 turns red.  
 Seven minutes after setting up the experiment, the litmus paper in tube 2 turns red.

- Use the kinetic particle theory to explain
- (i) how the gases move through the tubes, [2]  
 (ii) why the gases take different times to reach the litmus paper. [1]
- (b) A gas syringe is filled with  $80 \text{ cm}^3$  of hydrogen chloride gas at  $20^\circ \text{C}$ .  
 The syringe is placed in some hot water at  $50^\circ \text{C}$ .  
 The atmospheric pressure does not change but the volume of the gas in the syringe increases to  $88 \text{ cm}^3$ .

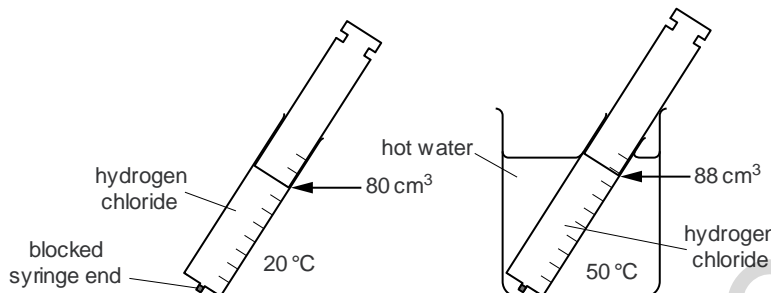

Use the kinetic particle theory to explain why the volume increases. [2]

**SOLUTION**

- (a) (i) Through diffusion, the gases move randomly from higher to lower concentration. Thus molecules spread out evenly throughout the tube  
 (ii) The gases have different relative molecular masses (*gases with higher Mr take more time to diffuse and vice versa*)
- (b) At higher temperature, molecules gain more kinetic energy and hence move faster hence they move furthest away from each other creating large intermolecular spaces

**2.2 Atomic Structure**

7

[J06/P2/QA2]

The diagram shows the nuclei of five different atoms.

key

○ neutron

● proton

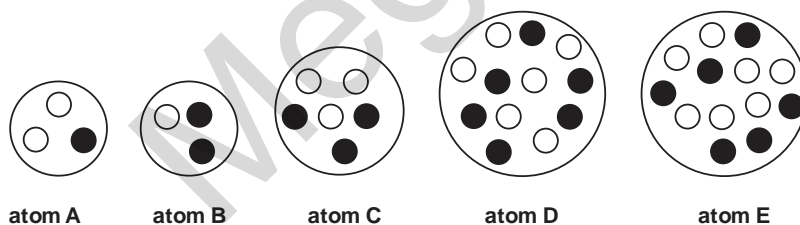

- (a) Which atom has an atomic number of 3? [1]  
 (b) Which atom has a mass number of 6? [1]  
 (c) Which **two** atoms are isotopes of the same element? [1]

- (d) Complete the table below to show the number of sub-atomic particles in both an atom and an ion of potassium.

|                     | potassium atom ${}^{39}_{19}\text{K}$ | Potassium ion ${}^{39}_{19}\text{K}^+$ |
|---------------------|---------------------------------------|--|
| number of protons   |                                       |  |
| number of electrons |                                       |  |
| number of neutrons  |                                       |  |

[2]

**SOLUTION**

- (a) C  
(Atomic number = number of protons present in the nucleus)
- (b) C  
(Mass number = number of protons + number of neutrons)
- (c) D and E  
(Isotopes of the same element having the same number of protons but different number of neutrons in their nuclei)
- (d)

|                     | potassium atom ${}^{39}_{19}\text{K}$ | Potassium ion ${}^{39}_{19}\text{K}^+$ |
|---------------------|---------------------------------------|--|
| number of protons   | 19                                    | 19                                     |
| number of electrons | 19                                    | 18                                     |
| number of neutrons  | 20                                    | 20                                     |

(Number of protons = atomic number; for atom and ion both  
Number of electrons = number of protons; for atom only  
However, in potassium ion, one electron has been removed giving the ion a charge of +1  
Number of neutrons = mass number; for atom and ion both)

**8**

**[N06/P2/QA4/c.]**

- (c) Complete the table to show the number of particles in two isotopes of argon.

| Isotope                 | number of protons | numbers of electrons | number of neutrons |
|-------------------------|-------------------|----------------------|--------------------|
| ${}^{36}_{18}\text{Ar}$ |                   |                      |                    |
| ${}^{40}_{18}\text{Ar}$ |                   |                      |                    |

[2]

**SOLUTION**

- (c)
- | Isotope                 | number of protons | number of electrons | number of neutrons |
|-------------------------|-------------------|---------------------|--------------------|
| ${}^{36}\text{Ar}_{18}$ | 18                | 18                  | 18                 |
| ${}^{40}\text{Ar}_{18}$ | 18                | 18                  | 22                 |

(Isotopes have same number of protons but different number of neutrons  
Number of protons and electrons = atomic number of the element  
Number of neutrons = mass number – atomic number)

**9**

**[J07/P2/QA3]**

Complete the table below to show the number of subatomic particles in each of the two ions.

| Ion                   | number of protons | number of neutrons | number of electrons |
|-----------------------|-------------------|--------------------|---------------------|
| $^{40}\text{Ca}^{2+}$ |                   |                    |                     |
| $^{37}\text{Cl}^{-}$  |                   |                    |                     |

[2]

**SOLUTION**

| Ion                   | number of protons | number of neutrons | number of electrons |
|-----------------------|-------------------|--------------------|---------------------|
| $^{40}\text{Ca}^{2+}$ | 20                | 20                 | 18                  |
| $^{37}\text{Cl}^{-}$  | 17                | 20                 | 18                  |

(Number of protons = proton number

Number of neutrons = nucleon number - proton number

In a neutral atom, number of electrons = number of protons but in  $\text{Ca}^{2+}$ , 2 electrons have been removed while in  $\text{Cl}^{-}$ , 1 electron is removed)

**10**

**[J07/P2/QB9/c]**

(c) Write an equation for the formation of aluminium oxide from its elements.

[1]

**SOLUTION**

(c)  $4\text{Al} + 3\text{O}_2 \rightarrow 2\text{Al}_2\text{O}_3$ .

**11**

**[J08/P2/QA3/a,b,c]**

A student found a copy of a Periodic Table published in the year 1930. Several elements were missing from this table because they had not yet been discovered. One of these elements was technetium, Tc.

One isotope of technetium has the symbol  $^{98}_{43}\text{Tc}$ .

(a) Complete the table below to show the number of subatomic particles in one atom of this isotope.

|                     |  |
|---------------------|--|
| number of protons   |  |
| number of electrons |  |
| number of neutrons  |  |

[2]

(b) Suggest the symbol of another isotope of technetium.

[1]

(c) Explain, in terms of subatomic particles and their charge, why an atom of  $^{98}_{43}\text{Tc}$  is electrically neutral.

[2]

**SOLUTION**

(a)

|                     |    |
|---------------------|----|
| number of protons   | 43 |
| number of electrons | 43 |
| number of neutrons  | 55 |



(In a neutral atom, number of protons=number of electrons.  
And number of neutrons = mass number – atomic number)

(b)  $\text{Tc}_{43}^{97}$

(Any mass number between 86 and 110 is suitable)

(c) The atom is neutral because it contains equal number of protons (+ve) and electrons (-ve)

12

[N08/P2/QB10/a]

Radioactive iodine is used to treat some cancerous tumours.

(a) Two radioactive isotopes of iodine are  $^{125}_{53}\text{I}$  and  $^{131}_{53}\text{I}$ .

For each isotope state the type and number of subatomic particles present.

[2]

**SOLUTION**

(a)

| Isotope               | Protons | Electrons | Neutrons |
|-----------------------|---------|-----------|----------|
| $^{125}_{53}\text{I}$ | 53      | 53        | 72       |
| $^{131}_{53}\text{I}$ | 53      | 53        | 78       |

13

[J09/P2/QA4]

The diagram shows the atomic structure of an atom of element X.

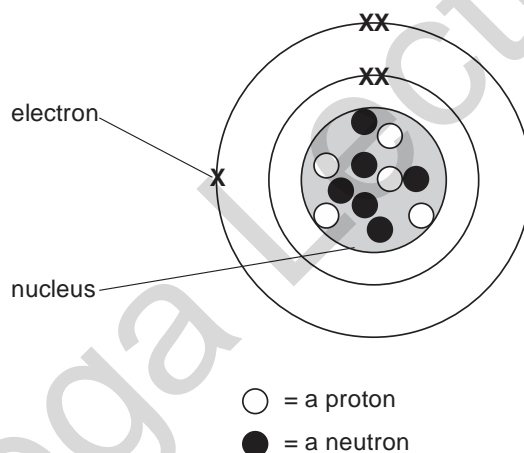

(a) Complete the table.

| sub-atomic particle | relative charge | relative mass |
|---------------------|-----------------|---------------|
| electron            | -1              |               |
| neutron             |                 |               |
| proton              |                 | 1             |

[2]

(b) Carbon-12 has the symbol  $^{12}_6\text{C}$ .

Write the symbol for an atom of element X.

[2]

(c) Draw a diagram to show the atomic structure of **another** isotope of element X.

[2]

**SOLUTION**

(a)

| Sub-atomic particle | Relative charge | Relative mass |
|---------------------|-----------------|---------------|
| Electron            | -1              | 1/1840        |
| Neutron             | 0               | 1             |
| Proton              | +1              | 1             |

(Other possible answer: relative mass of electron= negligible)

(b)



(c)

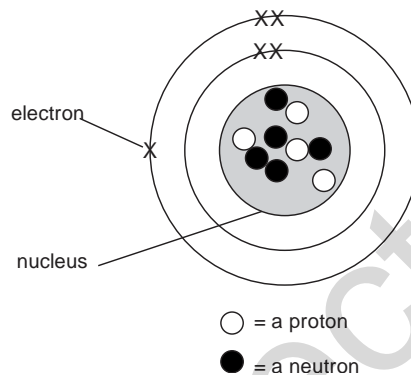

(Number of neutrons can be anywhere from 3 to 10)

**14**

**[N09/P2/QA3/b]**

- (b) Dry air contains about 1% of the argon-40 isotope,  ${}^{40}_{18}\text{Ar}$ .
- (i) What do you understand by the term *isotope*? [1]
- (ii) State the number of electrons and neutrons in this isotope of argon.  
 number of electrons [1]  
 number of neutrons [1]

**SOLUTION**

- (b) (i) Atoms of the same element having same proton number but different nucleon number  
 (ii) 18 electrons and 22 neutrons  
 (number of electrons=number of protons  
 number of neutrons=nucleon number-proton number)

**15**

**[J10/P2/QA2/a,b]**

Lithium, sodium and potassium are elements in Group I of the Periodic Table. Francium, Fr, is another element in Group I.

- (a) How many electrons are there in the outer shell of a francium atom? [1]  
 (b) Complete the following table about an atom of francium.

|                        |     |
|------------------------|-----|
| mass number            | 223 |
| proton (atomic) number |     |
| number of protons      |     |
| number of electrons    |     |
| number of neutrons     |     |

[2]

**SOLUTION**

- (a) 1 electron  
Group number = number of valence electrons.
- (b)

|                        |     |
|------------------------|-----|
| mass number            | 223 |
| proton (atomic) number | 87  |
| number of protons      | 87  |
| number of electrons    | 87  |
| number of neutrons     | 136 |

Atomic number of Fr is 87 as stated in periodic table.  
Number of protons is same as atomic number.  
Number of electrons is same as number of protons.  
Number of neutrons = mass number - atomic number i.e.  $223 - 87 = 136$ .

**16**

[J11/P2/QA4/b,e(i,ii)]

Fluorine, chlorine, bromine and iodine are elements in Group VII of the Periodic Table. Scientists are trying to synthesise a new element in Group VII with a proton number of 117.

- (b) Complete the following table about an isotope of this new element.

|                    |     |
|--------------------|-----|
| nucleon number     | 280 |
| number of protons  |     |
| number of neutrons |     |

**SOLUTION**

- (b)

|                           |                                     |
|---------------------------|-------------------------------------|
| <b>Nucleon number</b>     | <b>280</b>                          |
| <b>Number of protons</b>  | <b>117</b>                          |
| <b>Number of neutrons</b> | <b><math>280 - 117 = 163</math></b> |

Number of protons = proton number  
Number of neutrons = Nucleon number - proton number

**17**

[N11/P2/QA5/a,b,c(ii)]

Bromine is a halogen. It has two naturally-occurring isotopes.

- (a) Define the term *isotopes*. [1]
- (b) One isotope of bromine has the symbol  ${}_{35}^{81}\text{Br}$ .  
State the number of protons, neutrons and electrons in this isotope of bromine.  
protons

neutrons  
electrons

[2]

**SOLUTION**

- (a) Isotopes are the atoms of the same element having same number of protons but different number of neutrons  
 (b) Protons: **35**  
 Neutrons: **46**  
 Electrons: **35**

**18**

**[J12/P2/QA1/a,c,d,e,f]**

Choose from the following particles to answer the questions below.

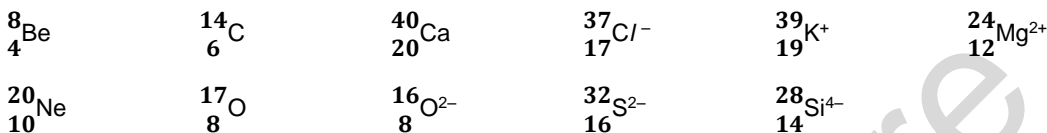

Each particle can be used once, more than once or not at all.

Which particle

- (a) has only eight electrons, [1]  
 (c) has only four electrons in its outer shell, [1]  
 (d) has only eight neutrons [1]  
 (e) has only ten protons, [1]  
 (f) has four occupied electron shells? [1]

**SOLUTION**

- (a) O (Proton number = number of electrons; in case of neutral atom not ions)  
 (c) C (Carbon has 2 electrons in its inner shell and 4 electrons in its outer shell)  
 (d) C/O<sup>2-</sup> (Neutrons = nucleon number – proton number)  
 (e) Ne (Protons = proton number)  
 (f) Ca (Electronic configuration = (2,8,8,2))

**19**

**[N12/P2/QA2/b(iii)]**

A student heated different mixtures of metals and metal oxides.

The table shows his results.

| mixture                | reacts or no reaction |
|------------------------|-----------------------|
| iron(III) oxide + zinc | reacts                |
| lead(II) oxide + iron  | reacts                |
| lead(II) oxide + zinc  | reacts                |
| magnesium oxide + zinc | no reaction           |

- (b) Aluminium is high in the reactivity series but does not appear to react with either water or acids.  
 (iii) Only one naturally-occurring isotope of aluminium is known.  
 State the number of protons and neutrons in this isotope of aluminium.  
 number of protons  
 number of neutrons

[1]

**SOLUTION**

- (b) (iii) Protons= 13  
Neutrons= 14  
(number of neutrons: 27-13 = 14)

**20** [N13/P2/QA3/a,b]

Silicon is an element in Group IV of the Periodic Table.

- (a) Give the electronic configuration for a silicon atom. [1]  
(b) Silicon has three naturally occurring isotopes.  
Complete the following table for two of these isotopes.

| Isotope             | <sup>28</sup> Si | <sup>30</sup> Si |
|---------------------|------------------|------------------|
| number of protons   |                  |                  |
| number of electrons |                  |                  |
| number of neutrons  |                  |                  |

[3]

**SOLUTION**

- (a) 2,8,4  
(b)

| Isotope             | <sup>28</sup> Si | <sup>30</sup> Si |
|---------------------|------------------|------------------|
| number of protons   | 14               | 14               |
| number of electrons | 14               | 14               |
| number of neutrons  | 14               | 16               |

(Isotopes have the same number of protons but different number of neutrons)

**21** [J14/P2/QB10/a]

Astatine, At, is an element in Group VII of the Periodic Table.  
The table shows some information about two isotopes of astatine.

| symbol                          | number of protons | number of electrons | number of neutrons |
|---------------------------------|-------------------|---------------------|--------------------|
| <sup>210</sup> <sub>85</sub> At | .....             | .....               | .....              |
| <sup>211</sup> <sub>85</sub> At | .....             | .....               | .....              |

- (a) (i) Complete the table. [2]  
(ii) What is meant by the term *isotopes*? [1]

**SOLUTION**

- (a) (i)

|                                 | Protons | Electrons | Neutrons |
|---------------------------------|---------|-----------|----------|
| <sup>210</sup> <sub>85</sub> At | 85      | 85        | 125      |
| <sup>211</sup> <sub>85</sub> At | 85      | 85        | 126      |

- (ii) Isotopes refers to the atoms of the same element having same atomic number but different mass numbers.  
(Isotopes have same number of protons but different number of neutrons)

22

[J15/P2/QA3]

Two isotopes of phosphorus are  $^{31}_{15}\text{P}$  and  $^{32}_{15}\text{P}$ .

- (a) State one difference and one similarity between these two isotopes.  
Difference  
Similarity [2]
- (b) Phosphorus forms simple molecules which have a relative molecular mass of 124.  
Suggest the formula of a phosphorus molecule. [1]
- (c) Phosphorus has a low melting point and does not conduct electricity.  
(i) Explain why phosphorus has a low melting point. [1]  
(ii) Explain why phosphorus does not conduct electricity. [1]
- (d) Complete the table for  $^{31}_{15}\text{P}^{3-}$ . [3]
- |                          |  |
|--------------------------|--|
| number of neutrons       |  |
| number of protons        |  |
| electronic configuration |  |
- (e) Phosphorus forms a compound called phosphine,  $\text{PH}_3$ .  
Draw the 'dot-and-cross' diagram to show the bonding in a molecule of phosphine.  
Only draw the outer shell electrons. [2]
- (f) Phosphine ignites in air to make water and phosphorus(V) oxide.  
Construct the equation for this reaction. [2]

**SOLUTION**

- (a) **Both these isotopes have different number of neutrons** (*number of neutrons = number of nucleons – number of protons*)  
Both the isotopes have same number of protons
- (b)  $\text{P}_4$  (*four atoms per molecule i.e.  $124/4=4$* )
- (c) (i)  $\text{P}_4$  has weak intermolecular forces between its molecules  
(ii) Phosphorus has no mobile electrons, all electrons are being used in the molecule

|                          |        |
|--------------------------|--------|
| number of neutrons       | 16     |
| number of protons        | 15     |
| electronic configuration | 2,8,10 |

(number of neutrons = nucleon number – proton number;  $31 - 15 = 16$   
electron number = proton number = 15,  $-3$  charge indicates that the element has gained 3 more electrons;  $15 + 3 = 18$  electrons)

(e)

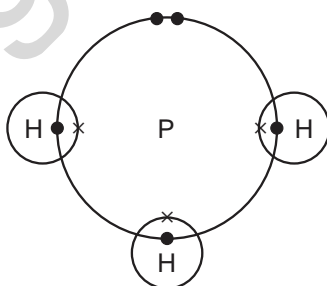

- (f)  $2\text{PH}_3 + 4\text{O}_2 \rightarrow \text{P}_2\text{O}_5 + 3\text{H}_2\text{O}$ .

23

[N15/P2/QB7/g,h]

- (g) An isotope of silicon is represented by the symbol  ${}_{14}^{29}\text{Si}$ .  
Deduce the number of protons and neutrons in this isotope.  
number of protons  
number of neutrons [1]
- (h) Silicon has a relative atomic mass of 28.  
Define the term *relative atomic mass*. [1]

**SOLUTION**

- (g) number of protons :14  
number of neutrons:  $29-14=15$  (*no. of neutrons = mass number – proton number*)
- (h) mass of an atom on a scale where carbon 12 atom weighs 12 units

24

[J16/P2/QA5/a,b,c,d]

The statements give some of the chemical properties of cobalt and its compounds.

- Cobalt does not react with cold water.
  - Cobalt fizzes slowly with dilute hydrochloric acid.
  - Cobalt does not react with aqueous zinc nitrate.
  - Cobalt reacts with aqueous silver nitrate.
  - Cobalt(II) oxide reacts with magnesium to form cobalt.
- (a) Use the information to help arrange the following metals in order of reactivity.  
cobalt, magnesium, silver, sodium and zinc  
most reactive  
least reactive [2]
- (b) Construct the equation for the reaction between cobalt(II) oxide, CoO, and magnesium. [1]
- (c) Predict what happens when cobalt(II) carbonate is heated strongly. [1]
- (d) Cobalt has a melting point of 1495 °C.  
Explain, in terms of structure and bonding, why a metal such as cobalt has a high melting point.  
You may use a labelled diagram in your answer. [2]

**SOLUTION**

- (a) **most reactive**  
Sodium  
Magnesium  
Zinc  
Cobalt  
Silver  
**least reactive**  
Silver  
Cobalt  
Zinc  
Magnesium  
Sodium
- (b)  $\text{CoO} + \text{Mg} \rightarrow \text{MgO} + \text{Co}$ .  
(*Mg being more reactive displaces Co from the oxide*)
- (c) It thermally decomposes to give CoO.  
 $\text{CoCO}_3 \rightarrow \text{CoO} + \text{CO}_2$
- (d) Cobalt has a melting point of 1495 °C.

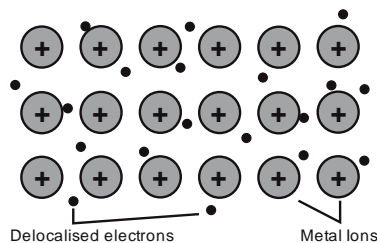

The Co cations have very strong electrostatic force of attraction with the delocalized electrons

## 2.3 Structures And Properties Of Materials

25

[J06/P2/QA5/a,b,c]

The structures of diamond, graphite and silicon carbide are shown below.

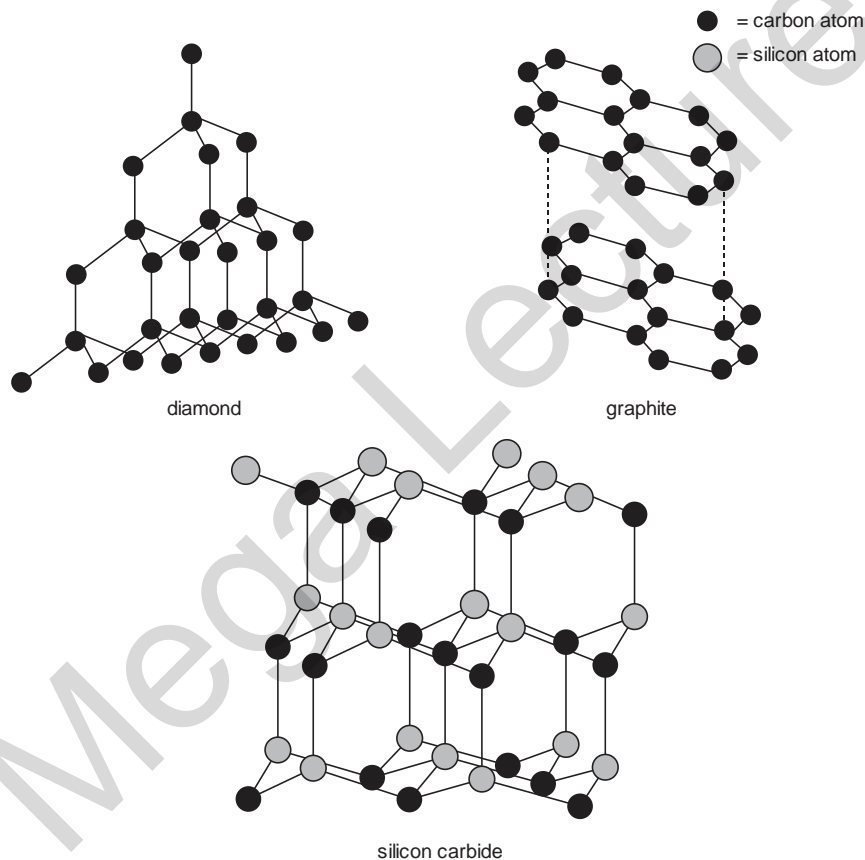

- (a) Suggest the formula for silicon carbide.
- (b) Explain why graphite conducts electricity but silicon carbide does not.
- (c) Silicon carbide has a very high melting point.

[1]  
[2]



- (i) Explain why silicon carbide has a very high melting point. [1]  
(ii) Suggest why the melting point of diamond is higher than that of silicon carbide. [1]

**SOLUTION**

- (a) SiC  
(b) In graphite, each carbon atom is covalently bonded to three other carbon atoms, so the fourth electron of every carbon atom is delocalized between the layers and hence is used in conduction of electricity. SiC has no such delocalized electron present  
(c) (i) SiC has a macromolecular structure with large number of strong covalent bonds present.  
(ii) The covalent bonds between carbon atoms in diamond are much stronger than those between silicon and carbon atoms in SiC

**26**

**[N06/P2/QA1/a(iii)]**

The diagram shows the structures of various compounds.

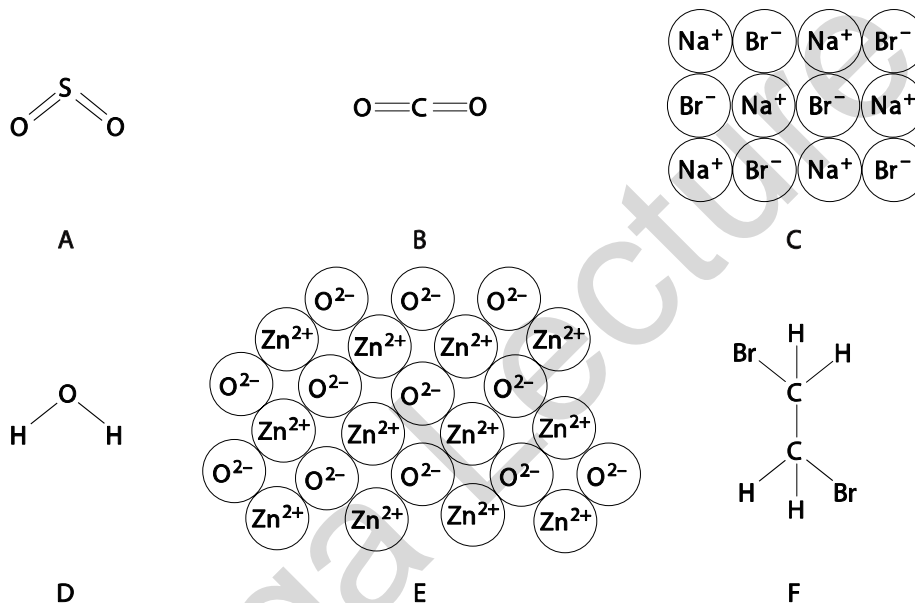

- (a) Use the letters **A** to **F** to answer the following.  
Each compound may be used once, more than once or not at all.  
(iii) Which **two** of these compounds have giant structures? [1]

**SOLUTION**

- (a) (iii) C and E  
(NaBr has a giant ionic lattice and ZnO has a giant metallic lattice)

**27**

**[J07/P2/QB9/d]**

This question is about the chemistry of the elements in Period 3 of the Periodic Table.

- (d) Pure sand is silicon (IV) oxide. It has a giant molecular structure similar to that of diamond.

Suggest **two** physical properties of silicon(IV) oxide.

[2]

**SOLUTION**

- (d) 1. High melting point  
2. Poor electrical conductor.  
(Other possible properties: High boiling point/poor heat conductor/insoluble in water)

**28**

**[N07/P2/QA4/a,b,c,d]**

In recent years scientists have made tube-shaped structures of carbon called nanotubes.

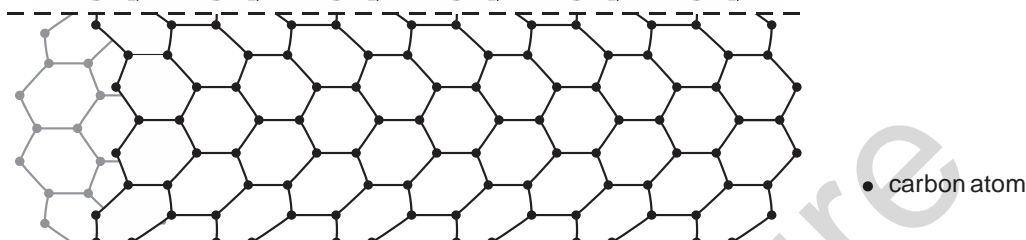

- (a) State **two** differences between the structure of a carbon nanotube and the structure of diamond. [2]  
(b) Carbon nanotubes are fifty times stronger than steel.  
Use ideas about structure and bonding to suggest why these nanotubes are so strong. [1]  
(c) Carbon nanotubes are good electrical conductors.  
(i) State the name of another form of carbon which can conduct electricity. [1]  
(ii) Carbon nanotubes conduct electricity nearly as well as copper.  
Explain why copper is a good conductor of electricity. [1]  
(d) Another form of carbon is buckminsterfullerene.

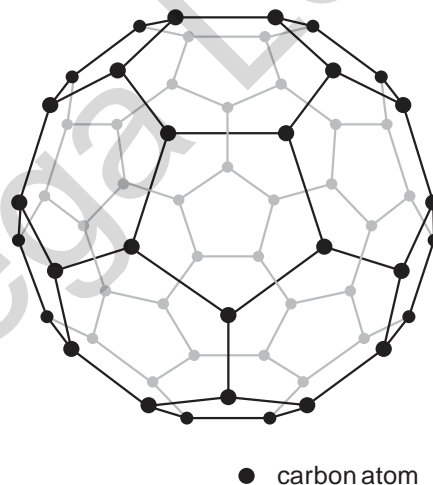

Argon can be trapped inside the cage-like structure of buckminsterfullerene.

- (i) Explain why argon is unreactive. [1]

- (ii) One isotope of argon is  ${}_{18}^{38}\text{Ar}$ .  
Calculate the number of neutrons in this isotope of argon. [1]

**SOLUTION**

- (a) Nanotubes have hexagons of carbon atoms while diamond has tetrahedrally arranged carbon atoms  
In nanotubes, each carbon is bonded to three other carbon atoms while in diamond, each carbon is bonded to four other carbon atoms  
*(Other possible differences: Nanotubes have a tubular structure while diamond has a non tubular structure. Nanotubes have delocalized electrons while diamond has no delocalized electrons)*
- (b) Carbon nanotubes have covalent, three dimensional macromolecular structure which is very strong as compared to metallic structure of iron
- (c) (i) Graphite  
(ii) Copper has delocalized electrons which help in conducting electricity
- (d) (i) Argon has a stable octet electronic configuration *(It has 8 electrons in its outer shell and, hence, does not react)*  
(ii) 20 *(Number of neutrons = nucleon number – proton number)*

**29**

**[N07/P2/QB10/a,b]**

Soda-lime glass is made by heating a mixture of calcium carbonate, sodium carbonate and sand in a furnace to a high temperature.  
Other glasses contain compounds called silicates. The simplified structures of a silicate and sodalime glass are shown.

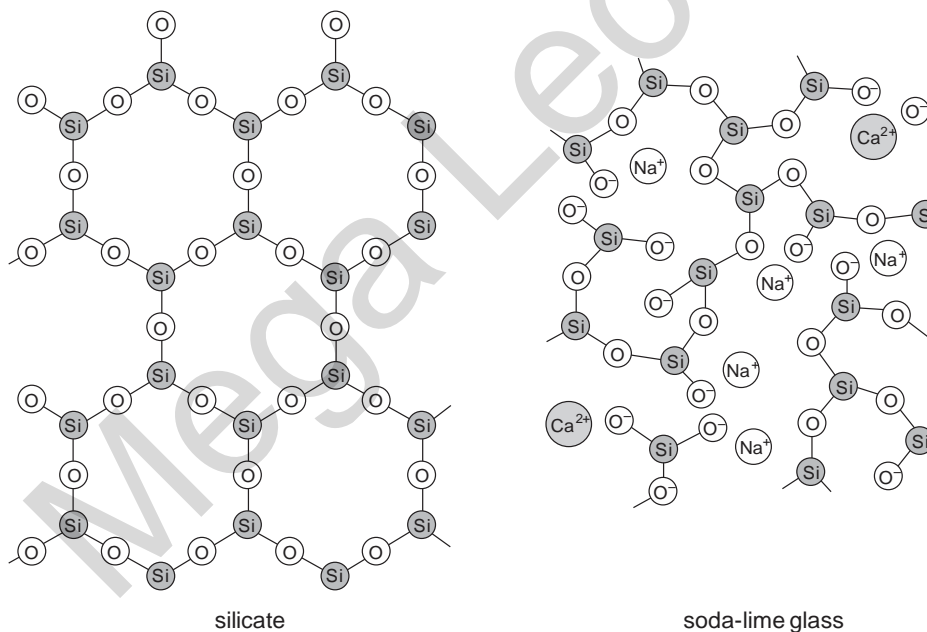

- (a) Describe two differences between the silicate and the soda-lime glass. [2]

- (b) When soda-lime glass is melted, it conducts electricity.  
Use the information in the diagram to explain this fact. [1]

**SOLUTION**

- (a) Silicate has regular arrangement of atoms and soda-lime glass has irregular arrangement of atoms  
Silicate has no ions and all atoms are covalently bonded while soda lime glass has calcium, sodium and oxide ions  
(Other possible differences: All the oxygen atoms are covalently bonded to two silicon atoms in silicate but in soda lime some are only bonded by one covalent bond  
Silicate has larger spaces and an open structure while soda-lime glass has a more compact structure)
- (b) Soda – lime glass has mobile ions ( $\text{Na}^{2+}$  and  $\text{Ca}^{2+}$ ) which help in conducting electricity.

**30**

**[N10/P2/QA5/a,c(ii,iii)]**

Carbon and graphite are two forms of carbon.

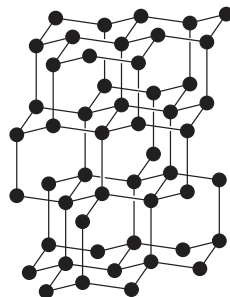

**diamond**

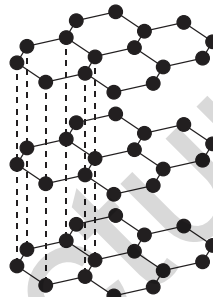

**graphite**

- (a) (i) Describe **two** differences in the structure of diamond and graphite. [2]  
(ii) Explain, in terms of their structure, why graphite is soft but diamond is hard. [2]
- (c) (ii) Carbon monoxide has a triple covalent bond. [2]  
Draw the electronic structure of carbon monoxide. Show only the outer electrons. [2]  
(iii) Carbon monoxide reacts with chromium to form chromium carbonyl. [2]  
The structure of chromium carbonyl is shown below.

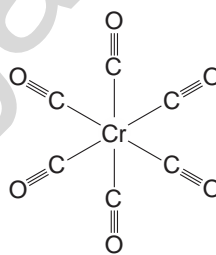

Write the empirical formula for chromium carbonyl. [1]

**SOLUTION**

- (a) (i) 1. In diamond, each carbon atom is bonded to four other carbon atoms while in graphite; each carbon atom is joined to three other carbon atoms.

2. In diamond, atoms are arranged tetrahedrally while in graphite; atoms are arranged in hexagonal layers.

- (ii) In graphite, there are weak intermolecular forces between the layers causing the layers to slide over each other. In diamond, covalent bonds are linked in all directions hence all atoms are in fixed positions.

(c) (ii)

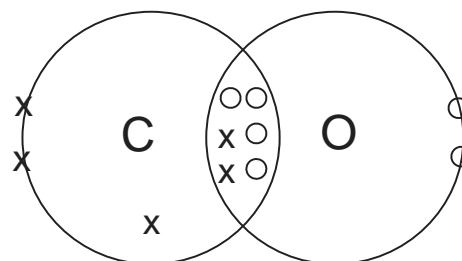

(iii)  $\text{CrC}_6\text{O}_6$

31

[J09/P2/QA2]

Boron nitride, BN, exists in two physical forms. The structures of these forms are shown below.

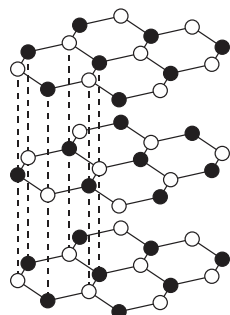

structure A

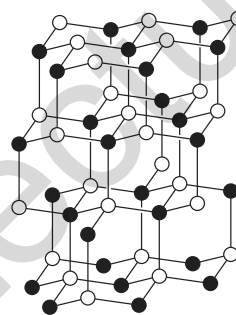

structure B

These two forms of boron nitride resemble two allotropes of carbon.

- (a) Suggest why boron nitride with structure A can be used as a lubricant. [2]  
 (b) Suggest why boron nitride with structure B does **not** conduct electricity. [1]  
 (c) Suggest why boron nitride with structure B can be used in cutting tools and drill bits. [2]

**SOLUTION**

- (a) Since there are weak van der Waals forces present between the layers, the layers can slide over each other, therefore boron nitride can be used as a lubricant (BN has a layered structure like graphite)  
 (b) No delocalized electrons are present in the structure B of BN (Each boron atom is bonded with three nitrogen atoms and each nitrogen atom is bonded with three boron atoms)  
 (c) It is hard and has a high melting point (Many covalent bonds are present in the structure which require a lot of energy to be broken down)

32

[J11/P2/QA5]

Blue diamonds are an impure form of carbon. Part of the structure of a blue diamond is shown below.

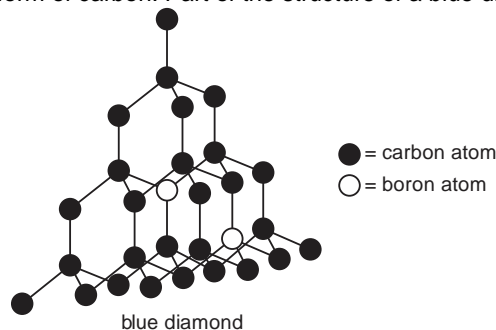

Blue diamonds have a high melting point and can conduct electricity.

- (a) Explain, in terms of structure and bonding, why blue diamonds have a high melting point. [2]
- (b) Normal diamonds are a pure form of carbon. They do not conduct electricity.
- (i) Explain, in terms of structure and bonding, why normal diamonds do **not** conduct electricity. [1]
- (ii) Suggest why blue diamonds can conduct electricity. [1]
- (c) Graphite is another pure form of carbon. Suggest **two** reasons why graphite is often used as an electrode in electrolysis.
- 1 [2]
- 2

**SOLUTION**

- (a) There are many strong covalent bonds which require a lot of energy to break them
- (b) (i) All electrons are involved in bonding and hence no free electrons are available to conduct electricity  
Each carbon is **covalently** bonded to **four** other carbon atoms
- (ii) It has delocalized electrons which are free to move  
**Delocalized electrons** may be present because of **metallic impurity**
- (c) 1. It is an electrical conductor due to the presence of delocalized electrons  
2. Graphite is generally unreactive  
Each carbon atom is **covalently** bonded to **three** other carbon atoms leaving **one** free electron.  
Also graphite has **high** boiling point and **does not** dissolve in water

33

[J12/P2/QA3/e]

- (e) Glass is made from sand.  
Pure sand has a giant molecular structure.

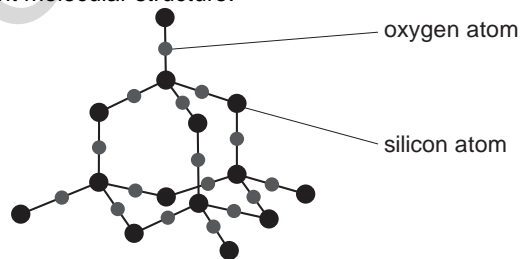

- (i) What is the formula for pure sand? [1]  
 (ii) Explain why sand has a very high melting point. [2]  
 (iii) Explain why sand does not conduct electricity. [1]

**SOLUTION**

- (e) (i)  $\text{SiO}_2$   
 (ii) Many covalent bonds are present in giant macromolecular  $\text{SiO}_2$  which require a lot of energy to break  
 (iii) Free/delocalized electrons are not present in  $\text{SiO}_2$

**34** [N12/P2/QA1/a]

- (a) Define the term *compound*. [1]

**SOLUTION**

- (a) A substance containing two or more elements chemically combines together in a fixed ratio by mass.

**35** [N12/P2/QB7(a)]

Glass contains silicon(IV) oxide and a number of metal oxides.

- (a) The structure of silicon(IV) oxide is shown below.

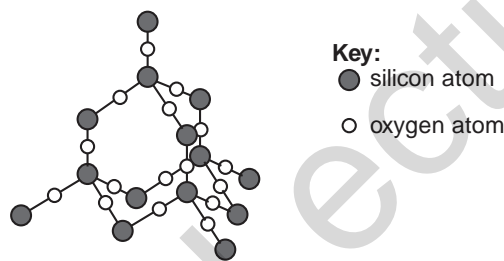

- (i) Describe **two** similarities in the structure of silicon(IV) oxide and diamond. [2]  
 (ii) Explain why silicon(IV) oxide has a high melting point. [2]  
 (iii) Explain why silicon(IV) oxide does not conduct electricity. [1]

**SOLUTION**

- (a) (i) Both have tetrahedral arrangement of atoms and both have giant molecular structures  
 (ii) It is a macromolecule containing many covalent bonds which require a lot of energy to be broken down.  
 (iii) No delocalized electrons are present, all electrons are involved in covalent bonding

**36** [J13/P2/QA1/d]

Choose from the following elements to answer the questions below.

**Barium**      **calcium**      **carbon**      **copper**      **helium**      **hydrogen**  
**Iron**        **lead**        **lithium**      **sulfur**      **zinc**

Each element can be used once, more than once or not at all.

Name an element which

- (d) has two giant molecular structures, [1]

**SOLUTION**

- (d) Carbon  
(Graphite and Diamond are two giant molecular structures made up of carbon atoms)

**37**

**[N13/P2/QA3/e]**

Silicon is an element in Group IV of the Periodic Table.

- (e) Silicon(IV) chloride reacts with water to form silicon(IV) oxide.  
Part of the structure of silicon(IV) oxide is shown below.

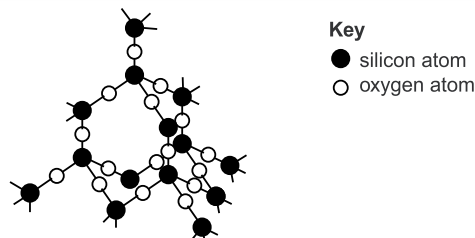

Explain, in terms of structure and bonding, why silicon(IV) oxide has a very high melting point. [2]

**SOLUTION**

- (e) Silicon (IV) oxide has a giant structure consisting of many strong covalent bonds which require a lot of energy to be broken down

**38**

**[N15/P2/QB7/a,b,c,d,e]**

The structures of diamond and silicon dioxide are shown.

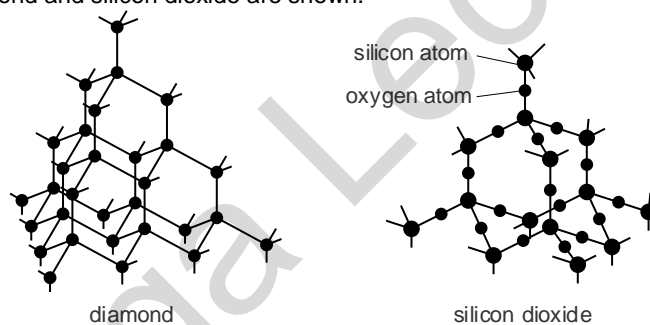

- (a) Describe one similarity in the structures of diamond and silicon dioxide. [1]  
(b) Explain why silicon dioxide has a high melting point. [2]  
(c) Silicon dioxide reacts with hot concentrated sodium hydroxide to form sodium silicate,  $\text{Na}_2\text{SiO}_3$ .  
Deduce the formula of the silicate ion. [1]  
(d) Explain why diamond does not conduct electricity. [1]  
(e) Graphite is a form of carbon which conducts electricity.  
Graphite is used as electrodes in electrolysis.  
What is the meaning of the term *electrolysis*? [1]

**SOLUTION**

- (a) The atoms are arranged tetrahedrally (Also, C in diamond and Si in silicon dioxide are both surrounded by 4 other atoms, both are giant macromolecular structures)  
(b) Silicon dioxide has a giant macromolecule structure and all the bonds are strong covalent bonds which require large amount of energy to break



- (c)  $\text{SiO}_3^{2-}$   
 (d) Diamond has no mobile electrons (or free electrons) as all electrons are involved in bonding  
 (e) Electrolysis refers to the breakdown of substances using electricity

## 2.4 Ionic Bonding

39

[J05/P2/QA1/b]

Choose from the following substances to answer the questions below.

aluminium oxide      ammonia      bariumsulphate      calcium carbonate  
 carbon monoxide      lead(II) iodide      nitrogen dioxide      silicon dioxide

Each substance can be used once, more than once or not at all.

Name a substance which

- (b) has a giant molecular structure, [1]

### SOLUTION

- (b) Silicon dioxide  
 (Silicon and oxygen combine with strong covalent bonds to give large macromolecular structure)

40

[J05/P2/QA6]

The structure of sodium chloride is drawn below

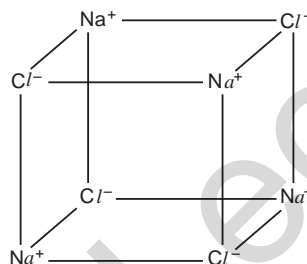

- (a) Sodium chloride is an ionic solid.  
 Draw the electronic structure of both a sodium ion and a chloride ion. sodium ion chloride ion [2]  
 (b) Sodium chloride has a melting point of about 800 °C.  
 (i) Explain why sodium chloride has a high melting point.  
 (ii) Magnesium oxide, MgO, has a similar structure to sodium chloride. Suggest why the melting point of magnesium oxide is higher than that of sodium chloride. [3]  
 (c) Explain why solid sodium chloride will not conduct electricity but molten sodium chloride will. [1]

### SOLUTION

(a)

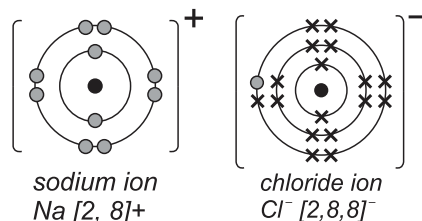

- (b) (i) The electrostatic forces between oppositely charged sodium and chloride ions are very strong.  
 (ii) Since the charges on both magnesium and oxide ions is higher, the electrostatic forces between them are higher than the forces between sodium and chloride ions.  
 (Respective charges on ions:  $Mg^{2+}$ ,  $O^{2-}$ ,  $Na^+$ , and  $Cl^-$ )
- (c) In solid state, ions are held in fixed positions, unable to move and conduct electricity. However, in molten state, ions are free to move and conduct electricity.

**41** [N05/P2/QA1/e]

These diagrams show the electron arrangement in the outer shells of five elements, A to E. All elements are from Period 3 of the Periodic Table

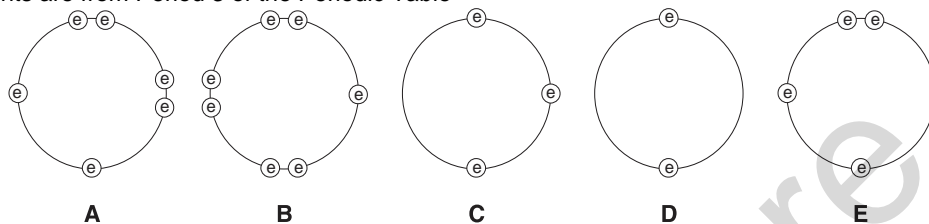

- (e) Which two elements will form an ionic compound with a formula of the type  $YZ_2$ ? [1]

**SOLUTION**

- (e) Element D and B  
 (Element D will transfer 1 electron each to 2 atoms of element B)

**42** [N05/P2/QA6/b]

The table below shows some information about two copper ores, tenorite and cuprite. Both contain copper oxide.

| ore      | formula of copper oxide in ore | oxidation number of copper | percentage of copper by mass |
|----------|--------------------------------|----------------------------|------------------------------|
| tenorite |                                | +2                         | 80.0%                        |
| cuprite  | $Cu_2O$                        |                            |                              |

- (b) Another ore of copper contains copper(II) sulphide. Complete the dot and cross diagram below for copper(II) sulphide showing outer electrons only.

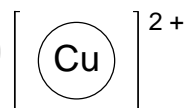

[2]

**SOLUTION**

- (b)

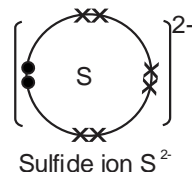

**43** [J06/P2/QB9/d]

(d) Give electronic structures, including the charges, of the ions present in potassium chloride. [2]

**SOLUTION**

(d)

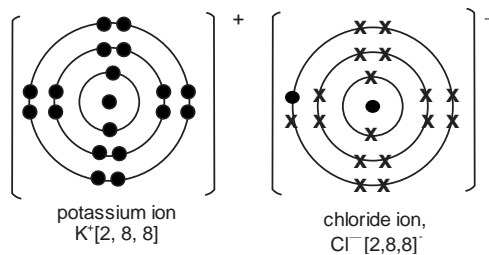

**44** [J07/P2/QB9/b]

(b) Draw electronic structures, including the charges, of the ions present in sodium oxide. Hence deduce the formula for sodium oxide. [2]

**SOLUTION**

(b)

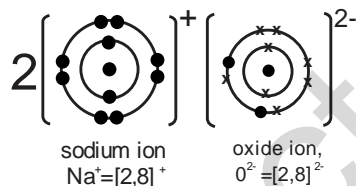

Formula: Na<sub>2</sub>O

**45** [J08/P2/QB7/b]

(b) Magnesium reacts with chlorine to form magnesium chloride. Draw diagrams to show the electronic structures and charges of both ions present in magnesium chloride. [2]

**SOLUTION**

(b)

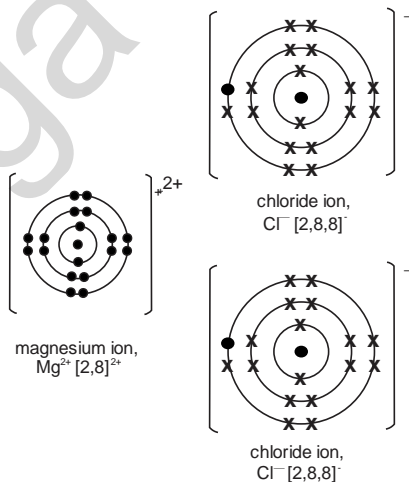

**46** [N08/P2/QB9/c]

- (c) Explain why aqueous sodium chloride solution conducts electricity but solid sodium chloride does not. [2]

**SOLUTION**

- (c) In aqueous sodium chloride, ions are free to move and conduct electricity. However, in solid sodium chloride ions are held in fixed position and, hence, they fail to conduct electricity.

**47** [J09/P2/QA5(b)]

Chlorine forms some compounds that are covalent and others that are ionic.

- (b) Calcium reacts with chlorine to form calcium chloride.  
Draw diagrams to show the electronic structures and charges of both ions present in calcium chloride. [2]

**SOLUTION**

- (b)

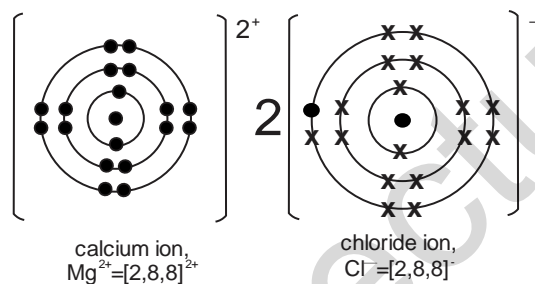

**48** [N09/P2/QA1/b,c]

- (b) Define the term *compound*. [1]  
(c) Explain why sodium iodide will **not** conduct electricity when solid but will conduct when dissolved in water. [2]

**SOLUTION**

- (b) A substance containing two or more elements chemically combine together in a fixed ratio by mass.  
(c) In solid state, ions will be fixed in position while in an aqueous solution, ions will move about freely, conducting electricity

**49** [J11/P2/QA4/d(ii)]

- (d) (ii) Give both the electronic configuration and the charge on the ions which are present in magnesium fluoride.

**SOLUTION**

- (d) (ii) Fluoride ion: electronic configuration: 2, 8 charge:  $\text{F}^-$   
Magnesium ion: electronic configuration: 2, 8 charge:  $\text{Mg}^{2+}$

**50** [N11/P2/QA2/d]

- (d) Oxygen reacts with magnesium to form magnesium oxide.

Draw diagrams to show the complete electronic structure and charges of both ions present in magnesium oxide. [2]

**SOLUTION**

(d)

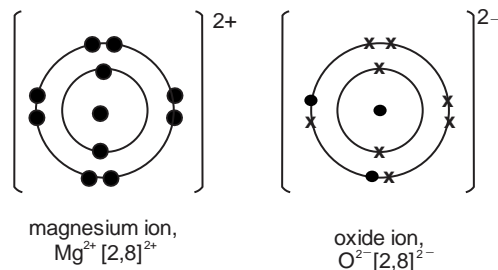

**51**

**[J12/P2/QB7/d(i)]**

(d) (i) Draw the electronic configuration and state the charge on each of the ions in calcium oxide. [2]

**SOLUTION**

(d) (i)

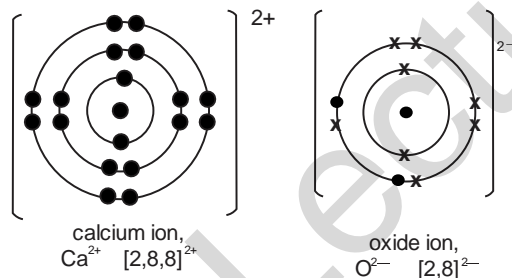

**52**

**[N12/P2/QB7(c)]**

(c) Sodium oxide is an ionic compound. Draw a 'dot-and-cross' diagram to show

- the arrangement of the outer shell electrons,
- the charges on the ions and
- the formula of sodium oxide.

[3]

**SOLUTION**

(c)

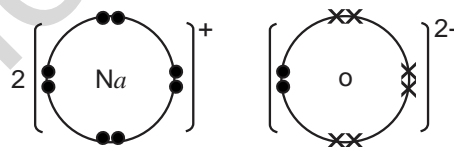

**53**

**[J13/P2/QB10/a]**

Solid sodium chloride and magnesium oxide have the same structure and bonding. This is the structure of sodium chloride.

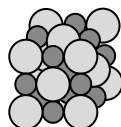

Key

● Na<sup>+</sup>

○ Cl<sup>-</sup>

The table shows the melting point of these two compounds.

| compound        | melting point / °C |
|-----------------|--------------------|
| magnesium oxide | 2852               |
| sodium chloride | 801                |

- (a) (i) What are the formulae for a magnesium ion and an oxide ion? [1]  
(ii) Suggest why magnesium oxide has a much higher melting point than sodium chloride. [1]

**SOLUTION**

- (a) (i) Mg<sup>2+</sup> and O<sup>2-</sup>  
(ii) These ions have higher charges resulting in stronger electrostatic forces of attraction

**54 [J14/P2/QB10/c(i)]**

- (c) (i) Describe how a magnesium ion and an astatide ion are formed from a magnesium atom and an astatine atom. [2]

**SOLUTION**

- (c) (i) Magnesium atom loses two electrons and gets a 2+ charge forming a Mg<sup>2+</sup> ion while two atoms of astatine gain one electron each forming At<sup>-</sup> ions.

**55 [N14/P2/QB6/a,b,c]**

The structures of sodium chloride and chlorine are shown below.

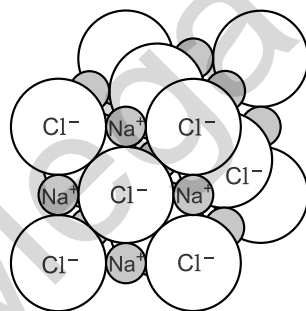

sodium chloride



chlorine

- (a) The melting point of sodium chloride is 801 °C.  
The melting point of chlorine is -101 °C.

- Explain, in terms of structure and bonding, the difference between the melting points of these two substances. [4]
- (b) Explain why molten sodium chloride conducts electricity but solid sodium chloride does not. [1]
- (c) Draw a 'dot-and-cross' diagram for sodium chloride, showing all the electron shells. [2]

**SOLUTION**

- (a) Sodium chloride has giant ionic structure made up of strong ionic bonds which need high temperature to break whereas chlorine is a simple molecule consisting of weak covalent bonds between the atoms. Covalent bonds can be easily broken by providing small amount of energy.
- (b) Molten sodium chloride has mobile ions which can move but solid sodium chloride has ions fixed in place and hence it cannot conduct electricity.
- (c)

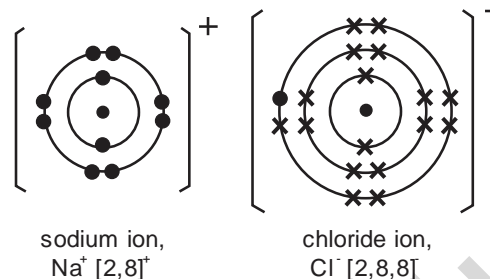

**56**

**[J16/P2/QA2/a,b,d]**

Hydrogen fluoride, HF, has a simple molecular structure. It is soluble in water.

- (a) Suggest **one** other physical property of hydrogen fluoride. [1]
- (b) Hydrogen fluoride dissociates in water to form dilute hydrofluoric acid.  
(i) Write an equation to show the dissociation of hydrogen fluoride. [1]  
(ii) Explain why an acidic solution is formed when hydrogen fluoride dissociates in water. [1]
- (d) Magnesium reacts with fluorine to make the ionic compound magnesium fluoride.  
(i) Predict **two** physical properties of magnesium fluoride. [2]  
(ii) Explain, in terms of electrons, how a magnesium atom reacts with a fluorine molecule,  $\text{F}_2$ , to make a magnesium ion and two fluoride ions. [2]

**SOLUTION**

- (a) It does not conduct electricity  
(simple molecular substances are water soluble, non conductors of heat and electricity, have low melting and boiling points and are gases or liquids at room temperature)
- (b) (i)  $\text{HF} \rightarrow \text{H}^+ + \text{F}^-$  setting needed  
(ii) Presence of  $\text{H}^+$  ions indicates an acidic solution
- (d) (i)  
1. conducts electricity in molten or aqueous solution  
2. High melting and boiling point  
(ii) Magnesium atom loses two valence electrons which are transferred to one fluoride atom each hence a positive magnesium ion and 2 negative fluoride ions are formed

## 2.5 Covalent Bonding

57

[N06/P2/QA6/a]

Methane,  $\text{CH}_4$ , is the major constituent of natural gas.

- (a) Draw a dot-and-cross diagram to show how the outer shell electrons are arranged in methane.  
show hydrogen electrons as  $\bullet$   
show carbon electrons as  $\times$

[1]

**SOLUTION**

(a)

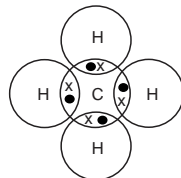

58

[J08/P2/QA4/b]

- (b) Draw a 'dot-and-cross' diagram for ethane.  
You only need to draw the outer electrons of the carbon atoms.

[2]

**SOLUTION**

(b)

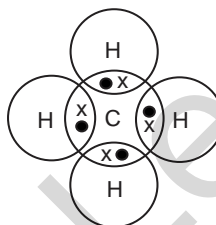

59

[J09/P2/QA5(a)]

Chlorine forms some compounds that are covalent and others that are ionic.

- (a) Draw a 'dot-and-cross' diagram for carbon tetrachloride,  $\text{CCl}_4$ .  
You only need to draw the outer electrons of the carbon and chlorine atoms.

[2]

**SOLUTION**

(a)

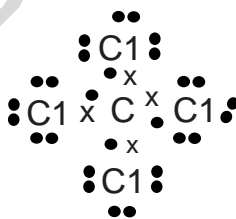

60

[N09/P2/QB9/b]

- (b) Draw a dot-and-cross diagram for carbon dioxide showing the outer electrons only.

[1]



**SOLUTION**

(b)

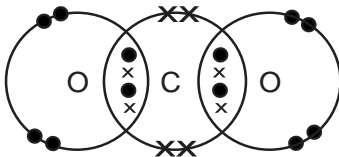

**61**

**[J10/P2/QB7/d(ii)]**

- (d) Hydrazine,  $N_2H_4$ , has similar chemical properties to ammonia.  
(ii) Hydrazine is a covalent compound. Draw a 'dot-and-cross' diagram for hydrazine. [2]

**SOLUTION**

- (d) (ii) • represent Electrons of N  
X represent Electrons of H

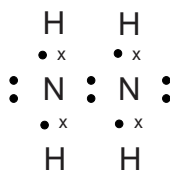

**62**

**[J11/P2/QA4/b,e(i,ii)]**

- (e) (i) Draw a 'dot-and-cross' diagram for a  $CF_3Cl$  molecule. You only need to show the outer electrons for each atom. [2]  
(ii) Trifluorochloromethane does not conduct electricity. Suggest one **other** physical property of trifluorochloromethane. [1]

**SOLUTION**

(e) (i)

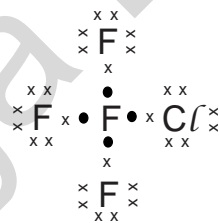

- (ii) It has a low melting point  
Other physical properties of **covalent molecules** include: **Poor** heat conductor, **low** boiling point, **low** density, **insoluble** in water

**63**

**[N11/P2/QA2/c]**

- Pure oxygen for industrial use is obtained from the air.  
(c) Acetylene has a triple covalent bond between its carbon atoms. Draw a 'dot-and-cross' diagram for acetylene. You need only show the outer electrons. [1]

**SOLUTION**

(c)

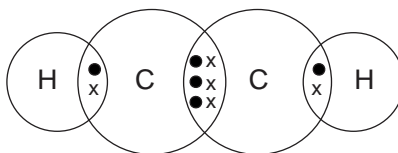

**64**

**[J12/P2/QA4/e]**

- (e) Carbon dioxide is a greenhouse gas. This is because its covalent bonds can absorb infra-red radiation.  
Draw a 'dot-and-cross' diagram to show the bonding in a molecule of carbon dioxide.  
Show only the outer shell electrons. [1]

**SOLUTION**

(e)

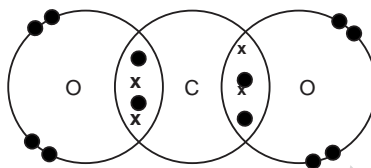

**65**

**[N12/P2/QA1/c]**

- (c) Draw a 'dot-and-cross' diagram for a molecule of water.  
Show only the outer shell electrons. [2]

**SOLUTION**

(c)

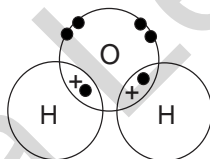

**66**

**[N12/P2/QA5/a(i)]**

Nickel can be refined by reacting the impure metal with carbon monoxide. The impurities do not react with carbon monoxide.  
A volatile compound called nickel carbonyl is formed.  
This is decomposed to give pure nickel and carbon monoxide.

- (a) (i) Explain the meaning of the term *volatile*. [1]

**SOLUTION**

- (a) (i) A substance is volatile if it evaporates easily to form a gas at normal room temperature and pressure

**67**

**[J13/P2/QA3/c]**

- (c) Iodine and bromine form the compound iodine bromide, IBr.  
Draw the 'dot-and-cross' diagram for IBr.

Only draw the outer shell electrons.

[1]

**SOLUTION**

(c)

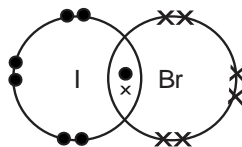

**68**

**[N13/P2/QA3/d(ii)]**

(d) (ii) Draw a 'dot-and-cross' diagram for silicon(IV) chloride.  
 You only need to show the outer shell electrons for each atom.

[2]

**SOLUTION**

(d) (ii)

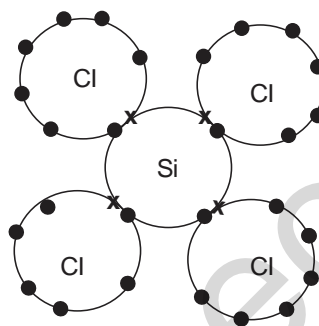

**69**

**[J14/P2/QB10/b]**

(b) Astatine forms a diatomic molecule with the same type of bonding as in a chlorine molecule.  
 Draw the 'dot-and-cross' diagram for an astatine molecule.  
 Only draw the outer shell electrons.

[1]

**SOLUTION**

(b)

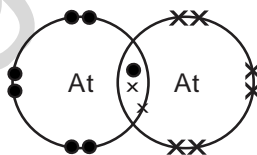

**70**

**[J16/P2/QA6/a]**

River water contains dissolved minerals and gases.

(a) Carbon dioxide is one of the gases dissolved in river water.  
 Draw the 'dot-and-cross' diagram to show the bonding in a molecule of carbon dioxide. Only draw the outer-shell electrons.

[1]

**SOLUTION**

(a)

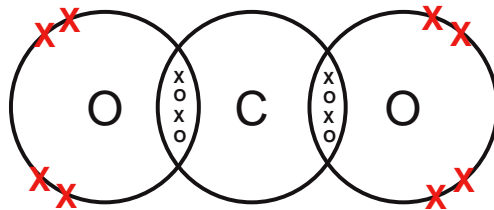

Mega Lecture

## UNIT-3 Formulae, Stoichiometry And The Mole Concept

### 1 [J05/P2/QA2/e]

- (e) A sample of a compound of iron is analysed. The sample contains 0.547 g of potassium, 0.195 g of iron, 0.252 g of carbon and 0.294 g of nitrogen.  
 Calculate the empirical formula of this compound. [3]

#### SOLUTION

| (e) Element        | P             | Fe      | C       | N       |
|--------------------|---------------|---------|---------|---------|
| Mass               | 0.547         | 0.195   | 0.252   | 0.294   |
| $A_r$              | 39            | 56      | 12      | 14      |
| No. of moles       | .547/39       | .195/56 | .252/12 | .294/14 |
| =                  | 0.014         | 0.003   | 0.021   | 0.020   |
| Simple ratio       | 4             | 1       | 6       | 6       |
| Empirical formula: | $K_4FeC_6N_6$ |         |         |         |

### 2 [J05/P2/QB7/c(iii)]

- (c) At room temperature ozone decomposes slowly to form oxygen,  $O_2$ .  
 The decomposition can be represented by the equation below. The reaction is exothermic. One mole of ozone will release 143 kJ when it is fully decomposed.  

$$2O_3 \rightarrow 3O_2$$
- (iii) Calculate the energy released when 16 g of ozone is decomposed. [6]

#### SOLUTION

- (c) (iii) Mass of ozone = 16 g  
 Molecular mass of ozone =  $3 \times 16 = 48$   
 Moles of ozone =  $16/48 = 0.333$   
 Energy released by 1 mole of ozone = 143 kJ  
 Energy released by 0.333 moles of ozone =  $143 \times 0.333 = 47.7$  kJ  
 (Moles = mass/ $M_r$ )

### 3 [J05/P2/QB8/a]

Sunglasses can be made from photochromic glass. When bright light strikes photochromic glass it darkens. Photochromic glass contains small amounts of silver chloride,  $AgCl$ , and copper(I) chloride,  $CuCl$ . In the presence of bright light, silver chloride decomposes into silver atoms which make the glass go dark, and into chlorine atoms.

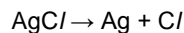

Chlorine atoms immediately react with copper(I) chloride to make copper(II) chloride.

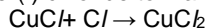

When the exposure to bright light ends, silver atoms reduce copper(II) chloride back into copper(I) chloride and silver chloride.

- (a) Calculate the maximum mass of silver that can be formed when 0.287 g of silver chloride decomposes. [2]

#### SOLUTION

- (a) Mass of silver chloride: 0.287 g

Molecular mass of silver chloride =  $108 + 35.5 = 143.5$  g  
 Moles of silver chloride =  $0.287/143.5 = 0.002$   
 Therefore, moles of silver =  $0.002$   
 Mass of silver =  $0.002 \times 108 = 0.216$  g  
 (Moles = mass/ $M_r$ )

**4** [J05/P2/QB10/e,f]

- (e) Magnesium reacts with ethanoic acid to make magnesium ethanoate and hydrogen. Write the equation for this reaction. Use the equation to calculate the mass of magnesium needed to react completely with  $50 \text{ cm}^3$  of  $1.0 \text{ mol/dm}^3$  of ethanoic acid. [3]
- (f) Suggest why the reaction between magnesium and  $1.0 \text{ mol/dm}^3$  ethanoic acid is much slower than the reaction between magnesium and  $1.0 \text{ mol/dm}^3$  hydrochloric acid. [2]

**SOLUTION**

- (e)  $\text{Mg} + 2\text{CH}_3\text{CO}_2\text{H} \rightarrow \text{Mg}(\text{CH}_3\text{CO}_2)_2 + \text{H}_2$   
 Moles of acid =  $(1.0/1000) \times 50 = 0.05$   
 Moles of Magnesium needed =  $0.05/2 = 0.025$   
 Mass of Magnesium =  $0.025 \times 24 = 0.60$  g  
 (Moles = mass x  $M_r$ )  
 (Moles = concentration x volume)
- (f) Ethanoic acid is a weak acid and ionizes partially giving lower concentration of  $\text{H}^+$  ions, therefore its reaction is slower than that of HCl which is a strong acid and ionizes completely when dissolved in water.

**5** [N05/P2/QA5/a(ii)]

An experiment was carried out to measure the rate of reaction between excess powdered calcium carbonate and dilute acids.

- (a) In **Experiment 1**,  $25 \text{ cm}^3$  of  $1.5 \text{ mol/dm}^3$  hydrochloric acid was used. Complete the equation for the reaction by filling in the missing state symbols.
- (ii) Calculate the total volume of carbon dioxide that is made from this reaction at r.t.p. [4]

**SOLUTION**

- (a) (ii) Moles of HCl =  $(25/1000) \times 1.5 = 0.0375$   
 Moles of  $\text{CO}_2$  produced =  $0.0375/2 = 0.01875$   
 Volume of  $\text{CO}_2$  =  $0.01875 \times 24 = 0.45 \text{ dm}^3$   
 (Moles = concentration x volume)  
 (Volume = moles x  $24 \text{ dm}^3$ )

**6** [N05/P2/QA6/a(iii)]

The table below shows some information about two copper ores, tenorite and cuprite. Both contain copper oxide.

| ore      | formula of copper oxide in ore | oxidation number of copper | percentage of copper by mass |
|----------|--------------------------------|----------------------------|------------------------------|
| tenorite |                                | +2                         | 80.0%                        |
| Cuprite  | $\text{Cu}_2\text{O}$          |                            |                              |

- (a) (iii) Calculate the percentage of copper by mass in  $\text{Cu}_2\text{O}$ . [5]

**SOLUTION**

- (a) (iii)  $(128/144) \times 100 = 88.73\%$   
 ( $M_r$  of  $\text{Cu}_2\text{O} = (64 \times 2 + 16) = 142$ )

**7 [J06/P2/QA4/d]**

- (d) Cement is made by heating calcium carbonate and clay together at a very high temperature. One of the compounds produced is a form of calcium silicate,  $\text{Ca}_3\text{SiO}_5$ . In the presence of water a chemical reaction takes place that helps in the setting of cement.  

$$2\text{Ca}_3\text{SiO}_5 + 6\text{H}_2\text{O} \rightarrow \text{Ca}_3\text{Si}_2\text{O}_7 \cdot 3\text{H}_2\text{O} + 3\text{Ca}(\text{OH})_2$$
 Calculate the mass of calcium hydroxide formed from 912 g of  $\text{Ca}_3\text{SiO}_5$ . [3]

**SOLUTION**

- (d)  $M_r$  of  $\text{Ca}_3\text{SiO}_5 = (40 \times 3) + 28 + (16 \times 5) = 228$   
 $M_r$  of  $\text{Ca}(\text{OH})_2 = 40 + (16 + 1) \times 2 = 74$   
 Mole ratio of  $\text{Ca}_3\text{SiO}_5 : \text{Ca}(\text{OH})_2 = 2 : 3$   
 45g of  $\text{Ca}_3\text{SiO}_5$  gives  $\text{Ca}(\text{OH})_2 = 222\text{g}$   
 912g of  $\text{Ca}_3\text{SiO}_5$  gives  $\text{Ca}(\text{OH})_2 = (222/456) \times 912 = 444\text{g}$

**8 [J06/P2/QA5(d)]**

- (d) When a 1.20 g sample of **graphite** is completely burnt in oxygen, 4.40 g of carbon dioxide are produced. What mass of carbon dioxide is made when a 1.20 g sample of **diamond** is completely burnt in oxygen? mass of carbon dioxide ..... g [1]

**SOLUTION**

- (d) 4.40 g  
 (*Diamond and graphite are allotropes of carbon having the same combustion equation*)

**9 [J06/P2/QB8/d]**

- (d) The concentration of dissolved oxygen in river water can be determined by a series of reactions that is summarised by the equation below.  

$$2\text{H}_2\text{O}(\text{l}) + \text{O}_2(\text{aq}) + 4\text{I}^-(\text{aq}) \rightarrow 4\text{OH}^-(\text{aq}) + 2\text{I}_2(\text{aq})$$
 When a 2000  $\text{cm}^3$  sample of river water was tested, 0.508 g of iodine was liberated. Calculate the concentration, in  $\text{mol/dm}^3$ , of dissolved oxygen in the river water sample. [3]

**SOLUTION**

- (d) Number of moles of  $\text{I}_2$  liberated =  $0.508 / (127 \times 2) = 0.02$  mole  
 (*Moles = mass/ $M_r$* )  
 Molar ratio of  $\text{I}_2$  to  $\text{O}_2 = 1 : 2$   
 Number of moles of  $\text{O}_2$  present =  $0.02 / 2 = 0.01$  mole  
 Volume of river water used = 2  $\text{dm}^3$   
 Concentration of oxygen =  $0.01 / 2 = 0.005$   $\text{mol/dm}^3$   
 (*Concentration = number of moles/volume*)

10

[J06/P2/QB9/c]

- (c) Potassium sulphate can be prepared by the reaction between dilute sulphuric acid and potassium carbonate.

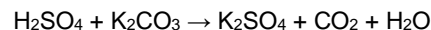

Calculate the mass of potassium sulphate that can be prepared from 3.45 g of potassium carbonate.

[3]

**SOLUTION**

- (c)  $M_r \text{ K}_2\text{CO}_3 = (39 \times 2) + 12 + (16 \times 3) = 138$   
 Number of moles of  $\text{K}_2\text{CO}_3$  being used =  $3.45/138 = 0.025$  mole  
 (Moles = mass/ $M_r$ )  
 molar ratio between  $\text{K}_2\text{CO}_3$  and  $\text{K}_2\text{SO}_4 = 1 : 1$   
 number of moles of  $\text{K}_2\text{SO}_4$  formed = 0.025 mole  
 mass of  $\text{K}_2\text{SO}_4$  formed =  $0.025 \times M_r$   
 $M_r$  of  $\text{K}_2\text{SO}_4 = (39 \times 2) + 32 + (1 \times 4) = 174$   
 Therefore, required mass =  $0.025 \times 174 = 4.35\text{g}$

11

[N06/P2/QA1/b]

The diagram shows the structures of various compounds.

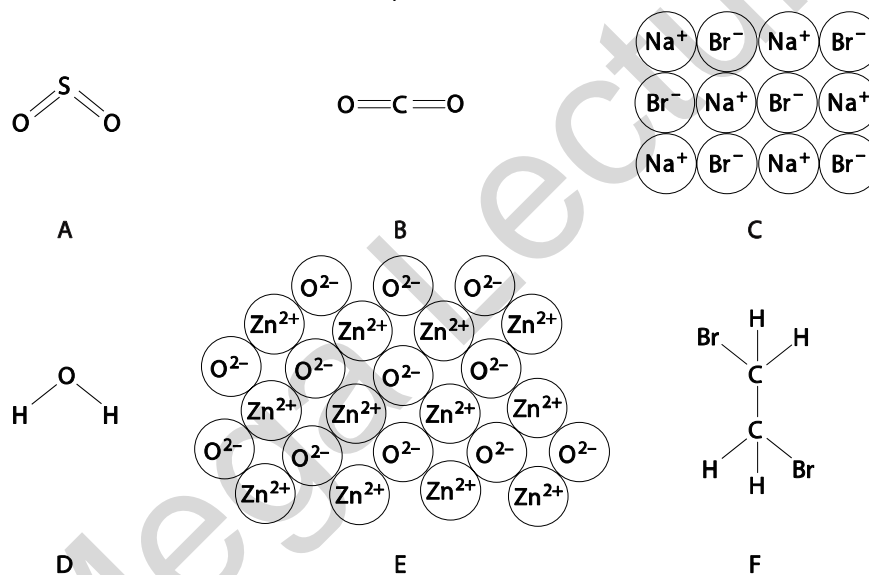

- (b) What is the empirical formula of compound F?

[1]

**SOLUTION**

- (b)  $\text{CH}_2\text{Br}$   
 (Empirical formula is the simplest ratio of the atoms present in a compound)



**12** [N06/P2/QA5/b(ii)]

- (b) (ii) Aluminiumsulphate contains  $\text{Al}^{3+}$  ions and  $\text{SO}_4^{2-}$  ions.  
Deduce the formula of aluminiumsulphate. [1]

**SOLUTION**

- (b) (ii)  $\text{Al}_2(\text{SO}_4)_3$

**13** [N06/P2/QB7/d]

- (d) Fertilisers are added to the soil to improve crop yields.  
A farmer has the choice of two fertilisers, ammonium nitrate,  $\text{NH}_4\text{NO}_3$ , or diammoniumhydrogen phosphate,  $(\text{NH}_4)_2\text{HPO}_4$ .  
Show by calculation which of these fertilisers contains the greater percentage of nitrogen bymass.  
You must show your working. [3]

**SOLUTION**

- (d)  $M_r$  of  $\text{NH}_4\text{NO}_3 = 14 + (1 \times 4) + 14 + (16 \times 3) = 80$   
%age of nitrogen by mass in  $\text{NH}_4\text{NO}_3 = (28/80)100 = 35\%$   
 $M_r$  of  $(\text{NH}_4)_2\text{HPO}_4 = (14 \times 2) + (1 \times 8) + 1 + 31 + (16 \times 4) = 132$   
%age of nitrogen by mass in  $(\text{NH}_4)_2\text{HPO}_4 = (28/132)100 = 21.2\%$

**14** [N06/P2/QB8/d]

- (d)  $12.0 \text{ cm}^3$  of an aqueous solution of sulphuric acid exactly neutralised  $20.0 \text{ cm}^3$  of a solution of sodium hydroxide of concentration  $0.150 \text{ mol/dm}^3$ .  
 $\text{H}_2\text{SO}_4 + 2\text{NaOH} \rightarrow \text{Na}_2\text{SO}_4 + 2\text{H}_2\text{O}$   
Calculate the concentration, in  $\text{mol/dm}^3$  of the aqueous sulphuric acid. [3]

**SOLUTION**

- (d) Moles of  $\text{NaOH} = 0.15 \times (20/1000) = 3 \times 10^{-3} \text{ mol}$   
(Moles = concentration  $\times$  volume)  
Mole ratio of  $\text{NaOH} : \text{H}_2\text{SO}_4 = 2 : 1$   
Therefore, moles of  $\text{H}_2\text{SO}_4 = 3 \times 10^{-3}/2 = 1.5 \times 10^{-3} \text{ mol}$   
Concentration =  $1.5 \times 10^{-3} \times 12/1000 = 0.125 \text{ mol dm}^{-3}$

**15** [N06/P2/QB9/c]

- (c) Butanoic acid can be converted into an ester by heating it with an alcohol and a few drops of concentrated sulphuric acid.  
A sample of an ester contains  $0.18 \text{ g}$  of carbon,  $0.03 \text{ g}$  of hydrogen and  $0.08 \text{ g}$  of oxygen.  
The relative molecular mass of the ester is  $116$ .  
Calculate both the empirical and molecular formulae of this ester. [3]

**SOLUTION**

| (c) | Element      | C             | H            | O             |
|-----|--------------|---------------|--------------|---------------|
|     | Mass         | 0.18          | 0.03         | 0.08          |
|     | $A_r$        | 12            | 1            | 16            |
|     | No. of moles | $0.18/12$     | $0.03/1$     | $0.08/16$     |
|     | =            | 0.015         | 0.03         | 0.005         |
|     | Simple ratio | $0.015/0.005$ | $0.03/0.005$ | $0.005/0.005$ |
|     | =            | 3             | 6            | 1             |

Thus, empirical formula =  $C_3H_6O$   
 Empirical formula mass of  $C_3H_6O = (12 \times 3) + (1 \times 6) + 16 = 58$   
 (Empirical formula mass)  $n =$  molecular formula mass  
 $(58) n = 116$   
 $n = 2$

Therefore, molecular formula of X =  $(C_3H_6O) \times 2 = C_6H_{12}O_2$   
 (Empirical formula mass  $\times n =$  molecular formula mass)

**16**

**[J07/P2/QA2/a,d]**

A fertiliser contains three compounds:

- ammonium sulphate,  $(NH_4)_2SO_4$ ,
- iron(II) sulphate,  $FeSO_4$ ,
- sand,  $SiO_2$ .

(a) Calculate the percentage by mass of nitrogen in ammonium sulphate. [2]

(d) The mass of iron(II) ions in a sample of fertiliser can be determined by the reaction between iron(II) ions and acidified potassium manganate(VII),  $KMnO_4$ .

A student analysed a sample of the fertiliser. He dissolved the sample in 25.0 cm<sup>3</sup> of dilute sulphuric acid and titrated the solution formed with 0.0200 mol / dm<sup>3</sup> potassium manganate(VII).

The student used 22.5 cm<sup>3</sup> of potassium manganate(VII) to reach the end-point.

(i) Calculate the number of moles of potassium manganate(VII) used in the titration. moles [1]

(ii) One mole of potassium manganate(VII) reacts with five moles of iron(II) ions. Calculate the mass, in grams, of iron(II) ions in the sample analysed. [2]

**SOLUTION**

(a)  $M_r$  of ammonium sulphate =  $[(14+4) \times 2] + 32 + (16 \times 4) = 132$

mass of nitrogen in ammonium sulphate =  $2 \times 14 = 28$

%age of nitrogen =  $(28/132) \times 100 = 21.2\%$

(d) (i) Moles of potassium manganate (VII) =  $(22.2/1000) \times 0.02 = 0.00045$   
 (Moles = concentration  $\times$  volume)

(ii) Moles of iron (II) ions =  $0.00045 \times 5 = 0.00225$

Mass of iron (II) ions =  $0.00225 \times 56 = 0.126g$

(Mass = moles  $\times M_r$ )

**17**

**[J07/P2/QA7/d]**

(d) The nitrates of metallic elements also decompose when heated.

Calcium nitrate decomposes to form calcium oxide, nitrogen dioxide and oxygen.

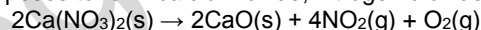

A 0.010 mol sample of calcium nitrate is heated. Calculate the number of moles of gas produced when this sample is completely decomposed. [1]

**SOLUTION**

(d) 2 moles of calcium nitrate produces 5 moles of gas ( $NO_2$  and  $O_2$ )

0.010 moles of calcium nitrate  $(5/2) \times 0.010 = 0.025$  moles

**18**

**[J07/P2/QA8/c]**

(c) Verdigris has the formula  $[Cu(CH_3CO_2)_2]_2 \cdot Cu(OH)_2 \cdot xH_2O$ .  
 It has a relative formula mass of 552.

Calculate the value of  $x$  in the formula.

[2]

**SOLUTION**

- (c)  $M_r$  of  $[\text{Cu}(\text{CH}_3\text{CO}_2)_2]_x \cdot x\text{H}_2\text{O} = 552$   
 $M_r$  of  $[\text{Cu}(\text{CH}_3\text{CO}_2)_2]_2 = 462$   
 $M_r$  of  $\text{H}_2\text{O} = 18$   
 Therefore,  $464 + x(18) = 552$   
 $18x = 552 - 462 = 90$   
 $x = 90/18 = 5$   
 $x = 5$

**19**

**[J07/P2/QB10/c(ii,iii)]**

- (C) The exhaust system of a motor car is fitted with a catalytic converter. When nitrogen monoxide passes through the converter it reacts with carbon monoxide.

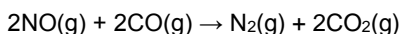

The diagram shows the energy profile for this reaction.

The catalyst increases the rate of this reaction.

- (ii) During the course of a journey  $2.4 \text{ dm}^3$  of nitrogen monoxide was produced by the engine. Calculate the volume of nitrogen gas produced if all the nitrogen monoxide reacted in the converter. [1]
- (iii) In reality, only  $1.0 \text{ dm}^3$  of nitrogen was produced after the gases had passed over the catalytic converter. Calculate the percentage of nitrogen monoxide that had reacted. [2]

**SOLUTION**

- (C) (ii) Volume on NO:  $2.4 \text{ dm}^3$   
 From the equation:  $\text{NO} : \text{N}_2 :: 2 : 1$   
 Therefore, volume of nitrogen gas produced =  $2.4/2 = 1.2 \text{ dm}^3$
- (iii) %age of NO = (volume of nitrogen produced/volume of nitrogen expected)  $\times 100$   
 =  $(1.0/1.2) \times 100 = 83.3\%$

**20**

**[J07/P2/QB11/c(ii)]**

- (c) (ii) The fermentation of glucose can be represented by the following equation.

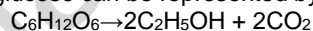

Calculate the maximum mass of ethanol that could be made from 36 tonnes of glucose. [3]

**SOLUTION**

- (c) (ii)  $M_r$  of  $\text{C}_6\text{H}_{12}\text{O}_6 = (12 \times 6) + (1 \times 12) + (16 \times 6) = 180$   
 $M_r$  of  $\text{C}_2\text{H}_5\text{OH} = (12 \times 2) + (1 \times 5) + 16 + 1 = 46$   
 Moles of glucose =  $36/180 = 0.2$  tonnes moles  
 Moles of ethanol =  $0.2 \times 2 = 0.4$  tonnes moles  
 Mass of ethanol =  $0.4 \times 46 = 18.4$  tonnes  
 (Moles = Mass/ $M_r$ )

**21**

**[J07/P2/QB12/d(ii)]**

- (d) (ii) What is the maximum mass of poly(ethene) that can be made from 28 tonnes of ethene? [1]

**SOLUTION**

- (d) (ii) 28 tonnes  
(No by product is formed in addition polymerization, and, hence, mass of polymer remains same as the mass of ethene)

**22** [N07/P2/QA5/b(ii,iii)]

- (b) (ii) A solution of tartaric acid was titrated with 0.100 mol/ dm<sup>3</sup> potassium hydroxide.  

$$\text{C}_2\text{H}_2(\text{OH})_2(\text{CO}_2\text{H})_2 + 2\text{KOH} \rightarrow \text{C}_2\text{H}_2(\text{OH})_2(\text{CO}_2\text{K})_2 + 2\text{H}_2\text{O}$$
 tartaric acid  
 It required 6.00 cm<sup>3</sup> of the potassium hydroxide solution to neutralise 20.0 cm<sup>3</sup> of tartaric acid. Calculate the concentration, in mol / dm<sup>3</sup>, of the tartaric acid solution. [3]
- (iii) Tartaric acid is purified by recrystallisation.  
 On analysis, 8.00 g of impure tartaric acid was found to contain 7.40 g of pure tartaric acid. Calculate the percentage purity of the impure tartaric acid. [1]

**SOLUTION**

- (b) (ii) Moles of KOH = 0.100 (6.00/1000) = 0.0006  
 Tartaric acid : KOH :: 1 : 2  
 Therefore, moles of tartaric acid = 0.0006/2 = 0.0003  
 Concentration of tartaric acid = (0.0003/20) 1000 = 0.015 mol dm<sup>-3</sup>  
 (Moles = concentration x volume)
- (iii) (7.40/8.00) x 100 = 92.5 %  
 [Percentage purity: (mass of pure substance/mass of impure substance) x 100]

**23** [N07/P2/QB7/c]

- (c) Carbon monoxide reacts with nickel to form a compound containing nickel, carbon and oxygen only. Analysis of 5.70 g of this compound showed that it contained 1.97 g nickel, 1.60 g carbon and 2.13 g oxygen.  
 Determine the empirical formula of this compound. [3]

**SOLUTION**

| Element      | Ni            | C             | O             |
|--------------|---------------|---------------|---------------|
| Mass         | 1.97          | 1.60          | 2.13          |
| Ar           | 59            | 12            | 16            |
| No. of moles | 1.97/59       | 1.60/12       | 2.13/16       |
|              | = 0.0333      | 0.1333        | 0.1331        |
| Simple ratio | 0.0333/0.0333 | 0.1333/0.0333 | 0.1331/0.0333 |
|              | = 1           | 4             | 4             |

Thus, empirical formula = NiC<sub>4</sub>O<sub>4</sub>

**24** [N07/P2/QB8/c]

- (c) Magnesium reacts with propanoic acid to form magnesium propanoate and hydrogen.

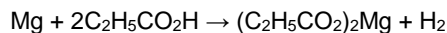

A student added 4.80 g of magnesium to 30.0 g of propanoic acid.

- (i) Which one of these reactants, magnesium or propanoic acid, is in excess?

- (ii) Explain your answer. [2]  
 Calculate both the number of moles of hydrogen and the volume of hydrogen formed at r.t.p. [2]

**SOLUTION**

- (c) (i) Moles of Mg =  $4.80/24 = 0.20$   
 Moles of propanoic acid =  $30.0/74 = 0.405$   
 0.20 moles of Mg reacts with 0.40 moles of propanoic acid, therefore propanoic acid is in excess (Moles = mass/M<sub>r</sub>)  
 (ii) Moles of H<sub>2</sub> = 0.20  
 Volume of H<sub>2</sub> =  $0.20 \times 24 = 4.80 \text{ dm}^3$   
 (Volume of gas = moles x 24dm<sup>3</sup>)

**25**

**[J08/P2/QA2/a,e]**

Iron(II) sulphate, FeSO<sub>4</sub>, is easily oxidised to iron(III) sulphate.

- (a) Calculate the percentage by mass of iron in iron(II) sulphate. [2]  
 (e) An impure sample of iron(II) sulphate was analysed by titration.  
 The sample was dissolved in 25.0 cm<sup>3</sup> of dilute sulphuric acid and then titrated against 0.0400 mol/dm<sup>3</sup> potassium dichromate(VI) solution.  
 19.0 cm<sup>3</sup> of potassium dichromate(VI) solution was required to reach the end-point.  
 (i) Calculate the number of moles of potassium dichromate(VI) used in the titration. [1]  
 (ii) One mole of potassium dichromate(VI) reacts with six moles of iron(II) ions.  
 Calculate the mass, in grams, of iron(II) ions in the sample analysed.  
 mass of iron(II) ions..... g [2]

**SOLUTION**

- (a) M<sub>r</sub> of FeSO<sub>4</sub> =  $56+32+(16 \times 4) = 152$   
 %age of Fe in FeSO<sub>4</sub> =  $(56/152) \times 100 = 36.8\%$   
 (e) (i) Number of moles of K<sub>2</sub>Cr<sub>2</sub>O<sub>7</sub> =  $0.0400 \times (19.0/1000) = 0.00076$  moles  
 (Moles = concentration x volume)  
 (ii) Moles of Fe<sup>2+</sup> =  $0.00076 \times 6 = 0.00456$  moles  
 Mass of Fe<sup>2+</sup> =  $0.00456 \times 56 = 0.255$  g  
 (Moles = mass x M<sub>r</sub>)

**26**

**[J08/P2/QB9/b]**

- (b) Magnesium ribbon reacts with hydrochloric acid as shown in the equation.

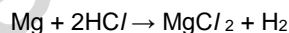

A 0.24 g sample of magnesium ribbon is added to 5.0 cm<sup>3</sup> of 2.0 mol/dm<sup>3</sup> hydrochloric acid.

- (i) Which reactant, magnesium or hydrochloric acid, is in excess? Use calculations to explain your answer. [2]  
 (ii) Calculate the maximum mass of magnesium chloride that can be formed in this reaction. [2]  
 (iii) A 0.24 g sample of magnesium ribbon is added to 5.0 cm<sup>3</sup> of 2.0 mol/dm<sup>3</sup> ethanoic acid.  
 Explain why this reaction forms the same volume of hydrogen but takes place much more slowly than the reaction of the same mass of magnesium with 5.0 cm<sup>3</sup> of 2.0 mol/dm<sup>3</sup> hydrochloric acid. [3]

**SOLUTION**

- (b) (i) Moles of Mg =  $0.24/24 = 0.01$   
 Moles of HCl =  $2 \times (5/1000) = 0.01$   
 According to equation, 0.01 mole of Mg needs 0.02 moles of HCl, therefore Mg is in excess  
 (Moles = mass/ $M_r$ )  
 (Moles = concentration x volume)
- (ii) 0.01 moles of HCl will produce 0.05 moles of  $MgCl_2$   
 therefore, mass of  $MgCl_2 = 0.005 \times 95 = 4.75$  g  
 (Moles = mass/ $M_r$ )
- (iii) Moles of Mg =  $0.24/24 = 0.01$   
 Moles of  $CH_3COOH = (2.0 \times 5)/1000 = 0.01$   
 Moles of  $H^+$  ions = 0.01  
 As the number of moles of  $H^+$  produced is same as in the case of HCl, therefore same volume of hydrogen will be produced.  
 Ethanoic acid will react slowly as compared to HCl, because ethanoic acid being weak acid will not ionize completely, therefore  $H^+$  ions produced will not be of the same concentration.

**27**

**[J08/P2/QB10/c(ii,iii)]**

- (c) A 1.2 g sample of powdered brass was analysed by reaction with excess dilute sulphuric acid. The zinc reacts as shown in the equation to form  $0.072 \text{ dm}^3$  of hydrogen measured at room temperature and pressure.
- $$Zn + 2H^+ \rightarrow Zn^{2+} + H_2$$
- (ii) Calculate the mass of zinc in the sample of brass. [2]  
 (iii) Calculate the percentage of zinc in the sample of brass. [1]

**SOLUTION**

- (c) (ii) Moles of hydrogen produced =  $0.072/24 = 0.003$   
 Moles of Zn (from equation) = 0.003  
 Mass of Zn =  $0.003 \times 65 = 0.195$  g  
 (Moles = mass x  $M_r$ )  
 Moles = volume/ $24 \text{ dm}^3$
- (iii) %age of Zn =  $(0.195/102) \times 100 = 16.25\%$

**28**

**[N08/P2/QA2/d,e]**

- (d) When 2 moles of magnesium react with one mole of carbon dioxide, 810 kJ of energy are released. Calculate the energy released when 2.0 g of magnesium reacts completely with carbon dioxide. [2]
- (e) In a second experiment 6.0 g of magnesium and 4.4 g of carbon dioxide are used. Which solid, magnesium or carbon dioxide is in excess? Show your working. [2]

**SOLUTION**

- (d) Moles of Mg =  $2/24 = 0.08333$   
 When 2 moles of Mg react with  $CO_2$ , energy released = 810 kJ  
 When 0.08333 moles of Mg react with  $CO_2$ , energy released =  $(810/2) \times 0.08333 = 33.75$  kJ  
 (Moles = Mass/ $M_r$ )
- (e) Moles of Mg =  $6/24 = 0.25$   
 Moles of  $CO_2 = 4.4/44 = 0.10$

0.10 moles of  $\text{CO}_2$  need 0.20 moles of Mg. Therefore, Mg is in excess  
(Moles = Mass/ $M_r$ )

**29** [N08/P2/QA4/c]

(c) Part of the chain structure of antimony sulphide is shown below.

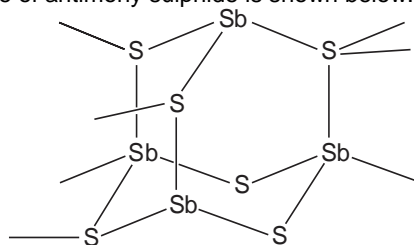

Deduce the empirical formula of antimony sulphide. [1]

**SOLUTION**

(c)  $\text{Sb}_2\text{S}_3$

**30** [N08/P2/QA5,b(iii)]

(b) (iii) 25.0  $\text{cm}^3$  of an aqueous solution of calcium hydroxide is exactly neutralised by 18.0  $\text{cm}^3$  of 0.040  $\text{mol/dm}^3$  hydrochloric acid.

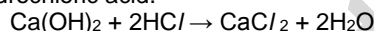

Calculate the concentration, in  $\text{mol/dm}^3$ , of the aqueous calcium hydroxide.  
concentration =  $\text{mol/dm}^3$

[3]

**SOLUTION**

(b) (iii) Moles of HCl = 0.040 (18/1000) =  $7.2 \times 10^{-4}$   
(CaOH) $_2$  and HCl react in the ratio 1:2  
Therefore, moles of (CaOH) $_2$  = ( $7.2 \times 10^{-4}$ )/2 =  $3.6 \times 10^{-4}$   
Concentration of Ca(OH) $_2$  = ( $3.6 \times 10^{-4}$ /25)  $\times$  1000 = 0.0144  $\text{mol/dm}^3$   
(Concentration = moles/volume 1 $\text{dm}^3$  = 1000 $\text{cm}^3$ )

**31** [N08/P2/QB8/c]

(c) Analysis of 10.0 g of carboxylic acid X shows that it contains 2.67 g carbon, 0.220 g hydrogen and 7.11 g oxygen.

(i) Deduce the empirical formula of X. [3]

(ii) The relative molecular mass of X is 90. Deduce the molecular formula of X. [1]

**SOLUTION**

| Element      | C           | H           | O           |
|--------------|-------------|-------------|-------------|
| Mass         | 2.67        | 0.220       | 7.11        |
| $A_r$        | 12          | 1           | 16          |
| No. of moles | 2.67/12     | 0.220/1     | 7.11/16     |
|              | = 0.2225    | 0.220       | 0.444       |
| Simple ratio | 0.223/0.220 | 0.220/0.220 | 0.446/0.220 |
|              | = 1         | 1           | 2           |

Thus, empirical formula =  $\text{CHO}_2$

(ii) Empirical formula mass of  $\text{CHO}_2$  = 12+1+ (16 $\times$ 2) = 45

(Empirical formula mass)  $n = 90$

(45)  $n = 90$

$n = 2$

Therefore, molecular formula of X =  $(\text{CHO}_2) \times 2 = \text{C}_2\text{H}_2\text{O}_4$

(Empirical formula mass  $\times n =$  molecular formula mass)

**32**

**[J09/P2/QA6/c]**

- (c) Calculate the mass of dissolved iron(II) ions,  $\text{Fe}^{2+}$ , in  $25 \text{ dm}^3$  of the aqueous waste.  
mass of iron(II) ions = ..... g [2]

**SOLUTION**

- (c) Moles of iron (II) ions =  $25 \times 0.450 = 11.25$   
mass of iron (II) ions =  $56 \times 11.25 = 630\text{g}$   
(Moles = concentration  $\times$  volume **AND** moles = mass  $\times$  Mr)

**33**

**[J09/P2/QB8/b]**

- (b) Octane burns in air.  
$$2\text{C}_8\text{H}_{18} + 25\text{O}_2 \rightarrow 16\text{CO}_2 + 18\text{H}_2\text{O}$$
  
A petrol-powered motor car travels at a constant speed of 80 km/h. For every kilometer travelled 108 g of carbon dioxide are formed.  
When the motor car travels 100 km calculate  
(i) the mass of carbon dioxide emitted by the car, [1]  
(ii) the mass of petrol burned by the car assuming that petrol is 100% octane. [4]

**SOLUTION**

- (b) (i)  $108 \times 100 = 10800\text{g} / 10.8 \text{ kg}$   
(ii) Moles of carbon dioxide =  $10\ 800 / 44 = 245.45$   
Molar ratio of  $\text{CO}_2$  : Octane:: 16 : 2 **OR** 1 : 8  
Moles of octane =  $245.45 / 8 = 30.68$   
 $M_r$  of octane 114  
Mass of octane =  $114 \times 30.68 = 3497.5\text{g}$   
(Moles = mass  $\times$  Mr)

**34**

**[J09/P2/QB9/d]**

- (d) Ethanol can also be manufactured from glucose,  $\text{C}_6\text{H}_{12}\text{O}_6$ .  
$$\text{C}_6\text{H}_{12}\text{O}_6 \rightarrow 2\text{CO}_2 + 2\text{C}_2\text{H}_5\text{OH}$$
  
A solution containing 18 kg of glucose makes only 0.92 kg of ethanol.  
Calculate the percentage yield of ethanol. [3]

**SOLUTION**

- (d) Moles of glucose =  $18 \times 1000 / 180 = 100$  moles  
Molar ratio of glucose to ethanol :: 1 : 2  
Moles of alcohol =  $100 \times 2 = 200$  moles  
Mass of alcohol =  $200 \times 46 = 9200 \text{ g} = 9.20 \text{ kg}$   
Actual (experimental) yield = 0.92 kg  
& age yield =  $(0.92/9.2)100 = 10\%$



35

[J09/P2/QB10/a]

Fertilisers supply the essential elements, nitrogen, phosphorus and potassium for plant growth. A bag of fertiliser contains 500 g of ammonium sulfate,  $(\text{NH}_4)_2\text{SO}_4$ , and 500 g of potassium nitrate,  $\text{KNO}_3$ .

- (a) Calculate the percentage by mass of nitrogen in the bag of fertiliser. [4]

**SOLUTION**

- (a)  $M_r$  of  $(\text{NH}_4)_2\text{SO}_4 = (14+4) \times 2 + 32 + (16 \times 4) = 132$   
 $M_r$  of  $\text{KNO}_3 = 39 + 14 + (16 \times 3) = 101$   
 Mass of nitrogen in 500 g of  $(\text{NH}_4)_2\text{SO}_4 = (28/132) 500 = 106.1 \text{ g}$   
 Mass nitrogen in 500 g  $\text{KNO}_3 = (14/101) 500 = 69.3 \text{ g}$   
 Total mass on nitrogen in the bag of fertilizer =  $106.1 + 69.3 = 175.4 \text{ g}$   
 %age of nitrogen in the bag of fertilizer =  $(175.4/1000) 100 = 17.5\%$

36

[N09/P2/QA3/d]

- (d) A small amount of xenon is present in the air. Several compounds of xenon have been made in recent years.  
 A compound of xenon contained 9.825 g of xenon, 1.200 g of oxygen and 5.700 g of fluorine. Determine the empirical formula of this compound. [3]

**SOLUTION**

| (d) | Element      | Xe                       | O                     | F                   |
|-----|--------------|--------------------------|-----------------------|---------------------|
|     | Mass         | 9.825                    | 1.200                 | 5.700               |
|     | Ar           | 131                      | 16                    | 19                  |
|     | No. of moles | $9.825/131$<br>$= 0.075$ | $1.200/16$<br>$0.075$ | $5.700/19$<br>$0.3$ |
|     | Simple ratio | $0.075/0.075$<br>$= 1$   | $0.075/0.075$<br>$1$  | $0.3/0.075$<br>$4$  |

Thus, empirical formula =  $\text{XeOF}_4$

37

[N09/P2/QA4/c,d(ii)]

Methylamine,  $\text{CH}_3\text{NH}_2$ , is a base which has similar properties to ammonia. When methylamine dissolves in water, the following equilibrium is set up.

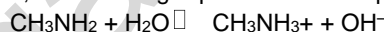

- (c) Methylamine is a gas. Calculate the volume occupied by 6.2 g of methylamine at room temperature and pressure. [2]  
 (d) (ii) Calculate the theoretical yield of methylamine that can be obtained from 240 kg of methanol. [2]

**SOLUTION**

- (c)  $M_r$  of methylamine =  $12 + (1 \times 3) + 14 + (1 \times 2) = 31$   
 Moles of methylamine =  $6.2/31 = 0.2$   
 Volume of methylamine =  $0.2 \times 24 = 4.8 \text{ dm}^3$   
 (Moles = mass/ $M_r$ )  
 Volume of gas = moles  $\times 24 \text{ dm}^3$   
 (d) (ii)  $M_r$  of  $\text{CH}_3\text{OH} = 12 + (1 \times 3) + 16 + 1 = 32$   
 Moles of  $\text{CH}_3\text{OH} = (240 \times 1000)/32 = 7500$

Molar ratio of  $\text{CH}_3\text{OH} : \text{CH}_3\text{NH}_2 :: 1 : 1$   
Hence, moles of  $\text{CH}_3\text{NH}_2 = 7500$   
Therefore, Mass of  $\text{CH}_3\text{NH}_2 = 7500 \times 31 = 232.5\text{kg}$

**38** [N09/P2/QB8/b]

- (b) A solution of fumaric acid was titrated against aqueous sodium hydroxide.  
 $\text{HO}_2\text{CCH}=\text{CHCO}_2\text{H} + 2\text{NaOH} \rightarrow \text{NaO}_2\text{CCH}=\text{CHCO}_2\text{Na} + 2\text{H}_2\text{O}$   
 18.0 cm<sup>3</sup> of 0.200 mol/dm<sup>3</sup> sodium hydroxide were required to neutralise 60.0 cm<sup>3</sup> of fumaric acid solution.  
 Calculate the concentration, in mol / dm<sup>3</sup>, of the fumaric acid solution. [3]

**SOLUTION**

- (b) Moles of NaOH =  $0.200 \times (18/1000) = 0.0036$   
 Molar ratio of NaOH to fumaric acid :: 2 : 1  
 Therefore, moles of fumaric acid =  $0.0036/2 = 0.0018$   
 Concentration of fumaric acid =  $0.0018/(60/1000) = 0.03\text{mol/dm}^3$   
 (Moles = concentration  $\times$  volume)

**39** [J10/P2/QA3/e]

- (e) Zinc is added to excess hydrochloric acid. Aqueous sodium hydroxide is added drop by drop to this reaction mixture until it is in excess. Describe what you would observe. [2]

**SOLUTION**

- (e) A white ppt will form which will dissolve in excess NaOH.  
*In the reaction of Zn and HCl, Zn<sup>2+</sup> ions are formed. These ions react with NaOH to produce white ppt of Zn(OH)<sub>2</sub> which is soluble in excess.*

**40** [J10/P2/QB8/a(iii)]

An ester is made from a carboxylic acid and an alcohol.  
 The carboxylic acid has the molecular formula C<sub>4</sub>H<sub>8</sub>O<sub>2</sub>. Analysis of the alcohol shows it has the following percentage composition by mass:  
 52.2% carbon; 13.0% hydrogen; 34.8% oxygen.

- (a) (iii) What is the empirical formula for the carboxylic acid? [1]

**SOLUTION**

(a) (iii) C<sub>2</sub>H<sub>4</sub>O

Empirical formula is the simplest whole number ratio of the atoms present in a compound.

| Element        | C            | H            | O             |
|----------------|--------------|--------------|---------------|
| Percentage     | 52.2         | 13.0         | 34.8          |
| A <sub>r</sub> | 12           | 1            | 16            |
| No. of moles   | $52.2/12$    | $13.0/1$     | $34.8/16$     |
|                | = 4.35       | 13.0         | 2.175         |
| Simple ratio   | $4.35/2.175$ | $13.0/2.175$ | $2.175/2.175$ |
|                | = 2          | 6            | 1             |

**41** [J10/P2/QB9/c,d(i)]

- (c) Calculate the maximum mass of hydrogen iodide that can be made from 45.3 g of hydrogen.  
 maximum mass of hydrogen iodide = ..... g [3]

- (d) Hydrogen iodide is dissolved in water to make solution X.  
(i) X is acidified with dilute nitric acid and then aqueous lead(II) nitrate is added. A yellow precipitate is formed.  
Write an ionic equation, including state symbols, for this reaction. [2]

**SOLUTION**

- (c) Moles of hydrogen = Mass(g)/Mr = 45.3/2 = 22.65 mol  
Molar ratio of H<sub>2</sub> to HI = 1 : 2  
Moles of HI = 22.65 × 2 = 45.3 mol  
Mass of HI = Moles of HI × Mr = 45.3 × 128 = 5798.4g
- (d) (i)  $\text{Pb}^{2+}(\text{aq}) + 2\text{I}^{-}(\text{aq}) \rightarrow \text{PbI}_2(\text{s})$   
PbI<sub>2</sub> is a yellow solid

**42 [J10/P2/QB10/b(ii)]**

- (b) (ii) Calculate the percentage by mass of nitrogen in ammonium phosphate.  
% by mass = ..... [2]

**SOLUTION**

- (b) (ii) %age by mass: (Ar of nitrogen/Mr of compound) 100  
Mr of a compound: (14+4) × 3 + 31 + 16 × 4 = 149  
(14×3/149) 100 = 28.2%

**43 [N10/P2/QA4/e]**

- (e) An aqueous solution of calcium hydroxide was titrated with 0.0150 mol / dm<sup>3</sup> hydrochloric acid.  
 $\text{Ca}(\text{OH})_2 + 2\text{HCl} \rightarrow \text{CaCl}_2 + 2\text{H}_2\text{O}$   
It required 6.00 cm<sup>3</sup> of this aqueous hydrochloric acid to neutralise 20.0 cm<sup>3</sup> of the calcium hydroxide solution.  
Calculate the concentration, in mol / dm<sup>3</sup>, of the calcium hydroxide solution. [3]

**SOLUTION**

- (e) Moles of HCl = 0.0150 × 0.006 = 0.00009 mol  
Molar ratio of Ca(OH)<sub>2</sub> to HCl = 1 : 2  
Moles of Ca(OH)<sub>2</sub> = 0.00009/2 = 0.000045 mol  
Concentration of Ca(OH)<sub>2</sub> = 0.000045/0.02 = 0.00225 mol dm<sup>-3</sup>  
Moles = concentration(mol/dm<sup>3</sup>) × volume (dm<sup>3</sup>)

**44 [N10/P2/QB7/e]**

- (e) Solid zinc chloride absorbs ammonia to form tetrammine zinc chloride, Zn(NH<sub>3</sub>)<sub>4</sub>Cl<sub>2</sub>.  
 $\text{ZnCl}_2 + 4\text{NH}_3 \rightarrow \text{Zn}(\text{NH}_3)_4\text{Cl}_2$   
Calculate the maximum yield, in grams, of tetrammine zinc chloride formed when 3.4 g of zinc chloride reacts with excess ammonia. [2]

**SOLUTION**

- (e) Mr of ZnCl<sub>2</sub> = 65.4 + (35.5 × 2) = 136.4  
Mr of Zn(NH<sub>3</sub>)<sub>4</sub>Cl<sub>2</sub> = 65.4 + (14 + 1 × 3) × 4 + (35.5 × 2) = 204.4  
Moles of ZnCl<sub>2</sub> = 3.4/136.4 = 0.0249  
Moles of Zn(NH<sub>3</sub>)<sub>4</sub>Cl<sub>2</sub> also = 0.0249

Mass of  $\text{Zn}(\text{NH}_3)_4\text{Cl}_2 = 0.0249 \times 204.4 = 5.1\text{g}$   
Moles = mass(g)/ $M_r$

**45**

**[J11/P2/QA3/d]**

- (d) Farmers that grow vegetable oil crops often use large quantities of ammonium nitrate fertiliser,  $\text{NH}_4\text{NO}_3$ .  
Calculate the percentage by mass of nitrogen in ammonium nitrate.  
percentage = %

[2]

**SOLUTION**

- (d) Molecular mass of  $\text{NH}_4\text{NO}_3 = 14 + (1 \times 4) + 14 + (16 \times 3) = 80$   
Mass of Nitrogen = 28  
%age of nitrogen =  $28/80 \times 100 = 35\%$

**46**

**[J11/P2/QB7/c]**

Nitric oxide, NO, is an atmospheric pollutant formed inside car engines by the reaction between nitrogen and oxygen.

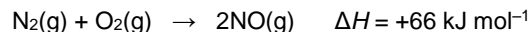

- This reaction is endothermic.  
(c) Calculate the mass of nitric oxide formed when 100 g of nitrogen reacts completely with oxygen. [3]

**SOLUTION**

- (c) Nitric oxide, NO, is an atmospheric pollutant formed inside car engines by the reaction between nitrogen and oxygen.

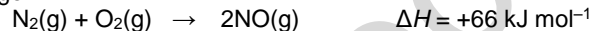

This reaction is endothermic.

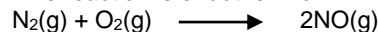

$$\text{moles of N}_2 = \frac{100}{28} = 3.57$$

moles ratio

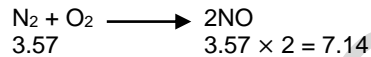

Thus mass of NO =  $7.14 \times 30 = 214.2\text{g}$

**47**

**[J11/P2/QB8/c(i)]**

- (c) In an experiment magnesium ribbon is added to  $25.0 \text{ cm}^3$  of  $1.00 \text{ mol/dm}^3$  hydrochloric acid, an excess.



Every 30 seconds the total volume of hydrogen formed is measured at room temperature and pressure. The results are shown on the grid below.

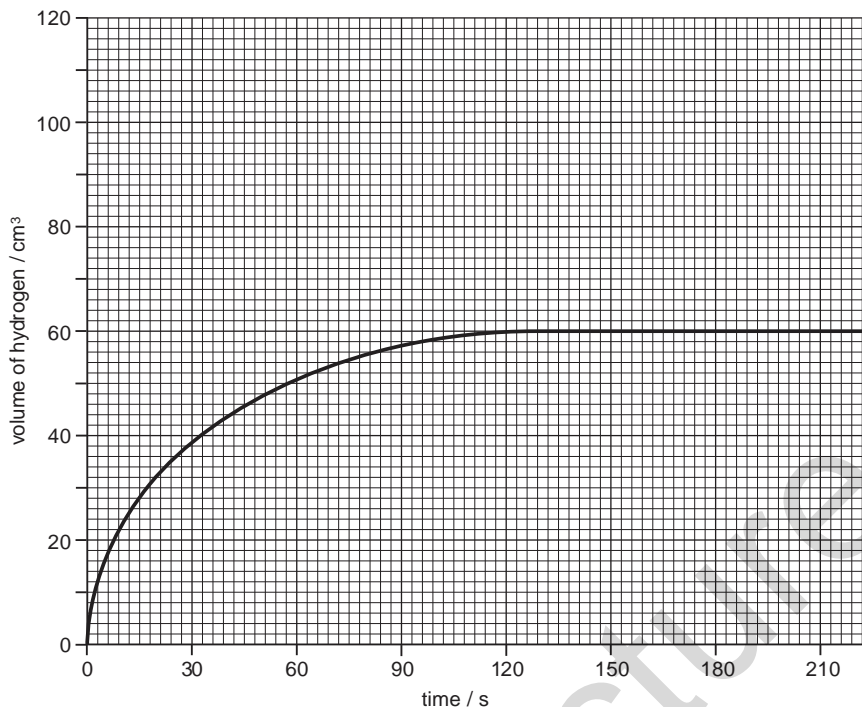

- (i) Use information from the graph to calculate the mass of magnesium ribbon used in the experiment.  
 [One mole of any gas at room temperature and pressure occupies a volume of 24 000 cm<sup>3</sup>.]  
 mass of magnesium ribbon = g [3]

**SOLUTION**

- (c) (i) Moles of hydrogen =  $60/24000 = 0.0025$  mol  
 moles of Magnesium = 0.0025 mol  
 mass of magnesium =  $0.0025 \times 24 = 0.06$  g  
**Moles = mass (g) / M<sub>r</sub>**

**48 [J11/P2/QB10/c(ii)]**

- (c) (ii) Calculate the maximum mass of ethanol that can be made from 1 tonne of glucose.  
 [One tonne is one million grams.]  
 maximum mass of ethanol = tonne [3]

**SOLUTION**

- (c) (ii) Moles of glucose =  $1000000/180 = 5555.55$  mol  
 Molar ratio of glucose : ethanol :: 1 : 2  
 Therefore, moles of ethanol =  $2 \times 5556 = 11112$  mol  
 mass of ethanol =  $11112 \times 46 = 511152$  g or 0.511 tonnes

49

[N11/P2/QA3/d]

- (d) A student ignites a mixture of 15 cm<sup>3</sup> of propane and 100 cm<sup>3</sup> of oxygen. The oxygen is in excess. All measurements of volume are taken at room temperature and pressure.

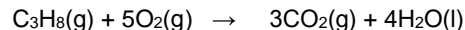

Calculate

the volume of carbon dioxide formed, cm<sup>3</sup>

[1]

the volume of unreacted oxygen remaining. cm<sup>3</sup>

[1]

**SOLUTION**

- (d) **Volume of CO<sub>2</sub> formed** = 15 × 3 = 45 cm<sup>3</sup>

Volume of O<sub>2</sub> used = 15 × 5 = 75 cm<sup>3</sup>

**Volume of unreacted oxygen remaining** = 100 – 75 = 25 cm<sup>3</sup>

Here **1 mole = 15 cm<sup>3</sup>**

ratio of propane : carbon dioxide :: 1 : 3

ratio of propane : oxygen :: 1 : 5

50

[N11/P2/QA5/d(ii)]

- (d) (ii) Another compound of bromine and fluorine is bromine(V) fluoride, BrF<sub>5</sub>.

Calculate the percentage of bromine by mass in bromine(V) fluoride.

[2]

**SOLUTION**

- (d) (ii) M<sub>r</sub> of BrF<sub>5</sub> = 80 + (19 × 5) = 175

A<sub>r</sub> of Br = 80

Percentage = (80/175) × 100 = 45.7%

51

[N11/P2/QB7/d(ii)]

- (d) (ii) A student reacts 3.0 g of magnesium with 2.5 mol / dm<sup>3</sup> sulfuric acid.

Calculate the minimum volume of sulfuric acid that reacts with all the magnesium.

[2]

**SOLUTION**

- (d) (ii) Moles of Mg = 3/24 = 0.125

Molar ratio of Mg : H<sub>2</sub>SO<sub>4</sub> :: 1 : 1

So, moles of H<sub>2</sub>SO<sub>4</sub> = 0.125

Vol. of H<sub>2</sub>SO<sub>4</sub> = (0.125/2.5) × 1000 = 50cm<sup>3</sup>

**Moles = mass/M<sub>r</sub>**

52

[N11/P2/QB8/c(i,ii)]

- (c) (i) Calculate the empirical formula of X.

[2]

- (ii) A molecule of carboxylic acid X contains four carbon atoms. What is its molecular formula?

[1]

**SOLUTION**

- (c) (i)

| Element        | C          | H         | O           |
|----------------|------------|-----------|-------------|
| Percentage     | 55.8       | 7.0       | 37.2        |
| A <sub>r</sub> | 12         | 1         | 16          |
| No. of moles   | 55.8/12    | 7.0/1     | 37.2/16     |
|                | = 4.65     | 7.0       | 2.325       |
| Simple ratio   | 4.65/2.325 | 7.0/2.325 | 2.325/2.325 |
|                | = 2        | 3         | 1           |

Thus, empirical formula = C<sub>2</sub>H<sub>3</sub>O

- (ii)  $C_4H_6O_2$   
*empirical formula x 2*

**53**

**[J12/P2/QA2/c]**

Small pieces of a silvercoloured metal, X, were added to concentrated nitric acid. A brown gas, Z, and a colourless solution containing salt Y were formed.

Analysis of a 0.0914 mol sample of Z showed it contained 1.28 g of nitrogen and 2.93 g of oxygen.

The small sample of the colourless solution was diluted with water and then divided into two portions.

- To one portion, aqueous sodium hydroxide was added drop by drop until it was in excess. A white precipitate, W, was formed that redissolved in the excess sodium hydroxide.
- To the other portion, aqueous ammonia was added drop by drop until it was in excess. A white precipitate, W, was formed that redissolved in the excess ammonia.

- (c) (i) Calculate the relative formula mass,  $M_r$ , for gas Z. [2]  
 (ii) Determine the molecular formula for Z.  
 molecular formula is [2]

**SOLUTION**

- (c) (i) Moles of sample = 0.0914 mol  
 Mass of sample = 1.28 + 2.93 = 4.21 g  
 $M_r = \text{mass/moles} = 4.21/0.0914 = 46$   
 ( $\text{Moles} = \text{mass}/M_r$ )
- (ii) Mole ratio:      Nitrogen                  Oxygen  
                                  1.28/14                          2.93/16  
                                  0.0914                          0.183  
                                  1    2  
 Molecular formula =  $NO_2$

**54**

**[J12/P2/QA5/c(ii),d]**

Aqueous potassium hydroxide, KOH, is added slowly from a burette into a flask containing 25.0 cm<sup>3</sup> of 0.0500 mol/dm<sup>3</sup> dilute sulfuric acid, H<sub>2</sub>SO<sub>4</sub>. At the same time the pH of the contents of the flask is measured until all of the aqueous potassium hydroxide has been added.

The graph shows how the pH changes with the addition of the aqueous potassium hydroxide.

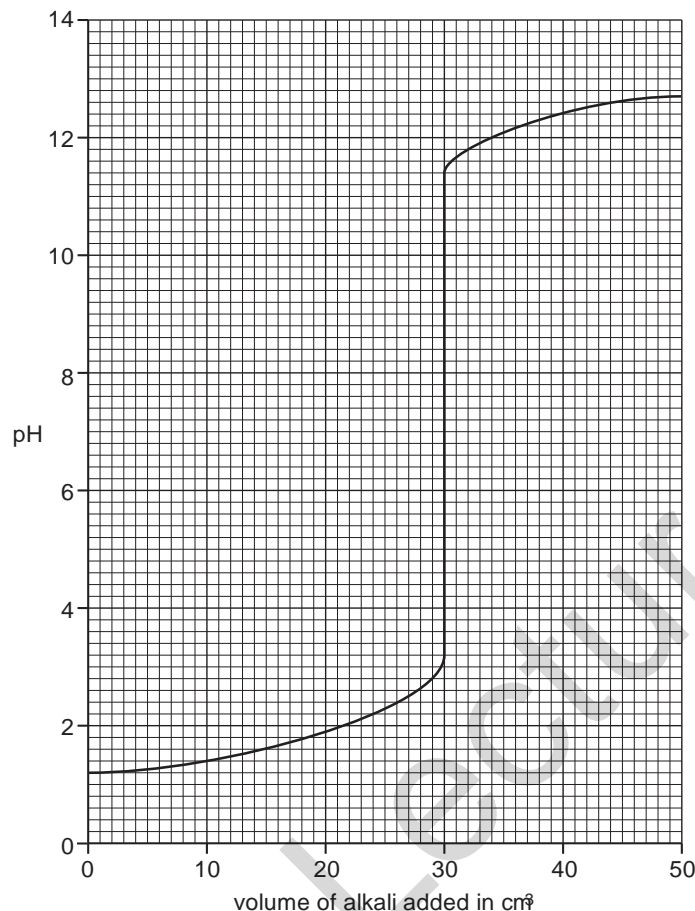

- (c) (ii) Calculate the concentration, in mol / dm<sup>3</sup>, of the aqueous potassium hydroxide.  
concentration = mol / dm<sup>3</sup> [3]
- (d) The experiment is repeated with 25.0 cm<sup>3</sup> of 0.0500 mol / dm<sup>3</sup> ethanoic acid, CH<sub>3</sub>COOH, instead of 25.0 cm<sup>3</sup> of 0.0500 mol / dm<sup>3</sup> sulfuric acid.  
Describe and explain any differences in the graph which would be obtained. [2]

**SOLUTION**

- (c) (ii) Moles of acid = (0.025 x 0.05) = 0.00125  
Moles of KOH = (0.00125 x 2) = 0.00250  
Concentration of KOH = 0.00250/0.030 = 0.0833 mol dm<sup>-3</sup>  
(Moles = concentration x volume)
- (d) Graph will start above pH 1.2 because ethanoic acid is a weak acid  
Vertical section of graph will be smaller because ethanoic acid is a weak acid  
(Another difference would be that the neutralization volume of KOH will be 15.0 cm<sup>3</sup> since CH<sub>3</sub>COOH and KOH react in a molar ratio of 1 : 1)



55

[J12/P2/QA5/a,b,c(i)]

Aqueous potassium hydroxide, KOH, is added slowly from a burette into a flask containing 25.0 cm<sup>3</sup> of 0.0500 mol / dm<sup>3</sup> dilute sulfuric acid, H<sub>2</sub>SO<sub>4</sub>. At the same time the pH of the contents of the flask is measured until all of the aqueous potassium hydroxide has been added.

The graph shows how the pH changes with the addition of the aqueous potassium hydroxide.

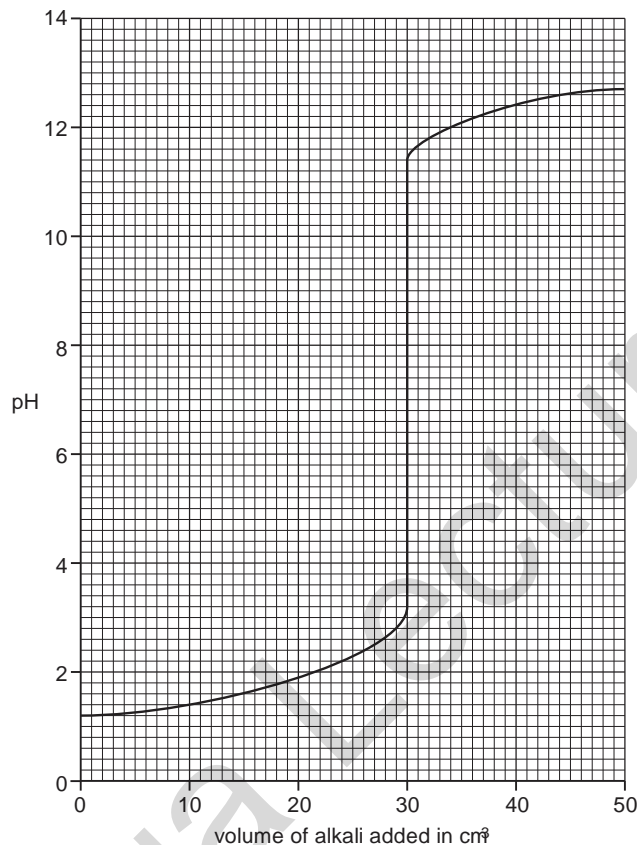

- (a) What is the pH of 0.0500 mol / dm<sup>3</sup> sulfuric acid? [1]  
 (b) Construct the equation for the reaction between sulfuric acid and potassium Hydroxide. [1]  
 (c) (i) What volume of aqueous potassium hydroxide has been added when the mixture has a pH of 7? [1]

**SOLUTION**

- (a) 1.2  
 (Read off from the graph)  
 (b)  $2\text{KOH} + \text{H}_2\text{SO}_4 \rightarrow \text{K}_2\text{SO}_4 + 2\text{H}_2\text{O}$   
 (c) (i) 30.0 cm<sup>3</sup>  
 (Read off from the graph)

**56** [J12/P2/QB6/c]

- (c) A hydrogen-oxygen fuel cell uses 2000 dm<sup>3</sup> of hydrogen measured at room temperature and pressure.  
Calculate the volume of oxygen, measured at room temperature and pressure, used by the fuel cell.  
[One mole of any gas at room temperature and pressure occupies a volume of 24 dm<sup>3</sup>.]  
volume of oxygen = dm<sup>3</sup> [2]

**SOLUTION**

- (c) Molar ratio of hydrogen : oxygen :: 2 : 1  
Volumes of gases are proportional to number of moles, therefore, volume of oxygen at r.t.p =  
2000/2 = 1000 dm<sup>3</sup>

**57** [J12/P2/QB7/a,c]

Many carbonates thermally decompose to form carbon dioxide and an oxide.  
Copper carbonate forms carbon dioxide and copper oxide.

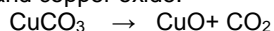

Six 2.00 g samples of carbonates are heated strongly until there is no further change in mass. The table shows the mass of solid remaining at the end of the heating.

| carbonate            | mass before heating / g | mass after heating / g |
|----------------------|-------------------------|------------------------|
| calcium carbonate    | 2.00                    | 1.12                   |
| copper(II) carbonate | 2.00                    | 1.29                   |
| iron(II) carbonate   | 2.00                    | 1.24                   |
| magnesium carbonate  | 2.00                    | 0.95                   |
| sodium carbonate     | 2.00                    | 2.00                   |
| zinc carbonate       | 2.00                    | 1.30                   |

- (a) What is the mass of carbon dioxide formed when 2.00 g of copper(II) carbonate is heated? [1]  
(c) For each carbonate, a 2.00 g sample was heated.  
Explain why the mass of carbon dioxide formed is different for each carbonate. [1]

**SOLUTION**

- (a) Mass of CO<sub>2</sub> = 2.00 – 1.29 = 0.71g  
(c) Percentage of carbon in each compound is different thus producing different masses of CO<sub>2</sub>.  
(Other possible answer: different amount in moles of carbonates may have been used)

**58** [J12/P2/QB9/c]

- (c) In the reaction when 3.0 moles of hydrogen react, 49 kJ of heat energy is released.  
Calculate how much heat energy is released when 500 kg of hydrogen react.  
heat energy = kJ [2]

**SOLUTION**

- (c) Moles of hydrogen = (500 × 1000)/2 = 250 000 mol  
3.0 moles of H<sub>2</sub> gives 49000 J so 250 000 moles of H<sub>2</sub> would give = (49000/3) 250000 = 4083 333  
333 J or 4083 333 KJ

59

[N12/P2/QB6/d]

- (d) The concentration of sodium chlorate(I) in a solution can be found by reacting sodium chlorate(I) with excess acidified potassium iodide and then titrating the iodine liberated with aqueous sodium thiosulfate,  $\text{Na}_2\text{S}_2\text{O}_3$ .

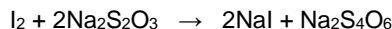

A solution of sodium thiosulfate contains 12.4 g of sodium thiosulfate,  $\text{Na}_2\text{S}_2\text{O}_3 \cdot 5\text{H}_2\text{O}$ , in 1.00 dm<sup>3</sup> of solution.

- (i) Calculate the concentration of the sodium thiosulfate solution in mol / dm<sup>3</sup>. [1]  
 (ii) 23.6 cm<sup>3</sup> of this sodium thiosulfate solution reacts with exactly 12.5 cm<sup>3</sup> of aqueous iodine.  
 Calculate the concentration, in mol / dm<sup>3</sup>, of the aqueous iodine. [3]

**SOLUTION**

- (d) (i) Mr of sodium thiosulfate =  $(23 \times 2) + (32 \times 2) + (16 \times 3) + 5(2+16) = 248$   
 Mass of sodium thiosulfate = 12.4g  
 Moles of sodium thiosulfate =  $12.4/248 = 0.05$  moles  
 Concentration =  $0.05/1.00 = 0.005$  mol dm<sup>-3</sup>  
 (Moles = mass/M<sub>r</sub>)  
 (Moles = conc × vol)  
 (ii) Moles of sodium thiosulfate =  $0.05 \times (23.6/1000) = 1.18 \times 10^{-3}$  mol  
 Moles of sodium thiosulfate and aqueous iodine are in the molar ratio of 2:1  
 Therefore, moles of iodine =  $1.18 \times 10^{-3} / 2 = 5.9 \times 10^{-4}$   
 Volume of aq. iodine in (dm<sup>3</sup>) =  $12.5/1000 = 0.0125$  dm<sup>3</sup>  
 Therefore, concentration of iodine =  $5.9 \times 10^{-4} \times 0.0125 = 0.0472$  mol/dm<sup>3</sup>

60

[N12/P2/QB8/c(i)]

- (c) (i) Calculate the percentage of nitrogen by mass in ammonium nitrate. [3]

**SOLUTION**

- (c) (i) Mr of ammonium nitrate =  $14 + (4 \times 1) + 14 + (16 \times 3) = 80$   
 %age of nitrogen by mass =  $[(2 \times 14)/80] \times 100 = 35\%$

61

[J13/P2/QA5/a]

Analysis of compound X shows it has the following composition.

| element  | percentage by mass |
|----------|--------------------|
| hydrogen | 3.40               |
| nitrogen | 12.0               |
| oxygen   | 41.0               |
| vanadium | 43.6               |

- (a) Show that X has the formula  $\text{H}_4\text{NO}_3\text{V}$ . [2]

**SOLUTION**

| (a) Element | H    | N    | O    | V    |
|-------------|------|------|------|------|
| Percentage  | 3.40 | 12.0 | 41.0 | 43.6 |
| Ar          | 1    | 14   | 16   | 51   |

|                     |           |             |            |             |
|---------------------|-----------|-------------|------------|-------------|
| <b>No. of moles</b> | 3.4/1     | 12/14       | 41/16      | 43.6/51     |
|                     | = 3.4     | 0.875       | 2.56       | 0.855       |
| <b>Simple ratio</b> | 3.4/0.855 | 0.875/0.855 | 2.56/0.855 | 0.855/0.855 |
|                     | = 4       | 1           | 3          | 1           |

Thus, empirical formula=  $H_4NO_3V$

**62**

**[J13/P2/QA6/b]**

A 0.250 g sample of iron filings is added to 25.0 cm<sup>3</sup> of 0.100 mol / dm<sup>3</sup> aqueous copper(II) sulfate.



(b) Show, by calculation, which reactant is in excess. [3]

**SOLUTION**

(b) Moles of Fe =  $0.250/56 = 0.00446$  mol  
 Moles of CuSO<sub>4</sub> =  $0.100 \times (25/1000) = 0.0025$  mol  
 Hence, Iron is in excess because it has a greater number of moles  
 (Moles = mass x M<sub>r</sub> and Moles= concentration x volume)

**63**

**[J13/P2/QB7/b(ii,iii)]**

An antacid tablet contains a mixture of magnesium hydroxide, Mg(OH)<sub>2</sub>, and calcium carbonate, CaCO<sub>3</sub>. Stomach acid contains dilute hydrochloric acid. A student adds a 0.500 g antacid tablet to 50.0 cm<sup>3</sup> of 1.00 mol / dm<sup>3</sup> hydrochloric acid, HCl. The acid is in excess.

The graph shows how the total volume of gas produced at r.t.p. changes with time.

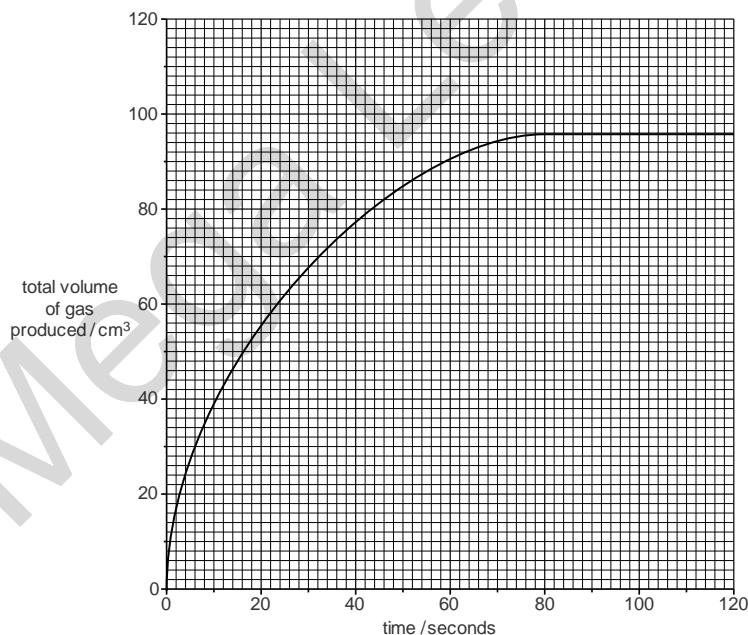

- (b) (ii) Calculate the amount, in moles, of carbon dioxide formed at r.t.p. once the reaction had stopped. [2]  
(iii) Calculate the mass of CaCO<sub>3</sub> in the tablet. [2]

**SOLUTION**

- (b) (ii) Volume of CO<sub>2</sub> produced (read off from the graph) is 96 cm<sup>3</sup>  
1 mol = 24 dm<sup>3</sup>  
x mol = 0.096 dm<sup>3</sup>  
x = 0.004 mol  
(iii) M<sub>r</sub> of CaCO<sub>3</sub> = 100  
Mass of CaCO<sub>3</sub> = 100 x 0.004 = 0.40g  
(Moles = mass x M<sub>r</sub> )

**64**

**[J13/P2/QB9/d]**

Methane reacts with water to produce hydrogen and carbon monoxide.

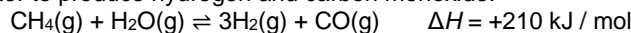

This reaction is endothermic.

The reaction is normally carried out at a pressure of 30 atmospheres and a temperature of 850 °C.

- (d) Calculate the energy absorbed by the reaction when 560 g of CO is formed. [2]

**SOLUTION**

- (d) Moles of CO = 560/28 = 20 mol  
Energy absorbed when 20 moles of CO are formed = 210 × 10 = 4200 KJ

**65**

**[J13/P2/QB10/c(ii)]**

- (c) Sodium chloride is dissolved in distilled water.  
Excess aqueous silver nitrate is added to this solution and 0.232 g of a white precipitate is formed.  
(ii) Calculate the mass of sodium chloride present in the solution. [3]

**SOLUTION**

- (c) (ii) M<sub>r</sub> of AgCl = 143.5 and M<sub>r</sub> of NaCl = 58.5  
Moles of AgCl = 0.232/143.5 = 0.00162  
Mass of NaCl = 0.00162 × 58.5 = 0.0948g  
(Moles = mass × M<sub>r</sub> )

**\*Explanations and other possible answers in Italic**

NOTE; ALWAYS ADD a fullstop when the reaction is complete

**66**

**[N13/P2/QA5/c]**

- (c) Magnesium reacts with carbon to form the compound magnesium carbide.  
Calculate the percentage by mass of magnesium in magnesium carbide, MgC<sub>2</sub>. [2]

**SOLUTION**

- (c) Molar mass of MgC<sub>2</sub>=48  
mass of Mg=24  
percentage=(24/48) × 100 = 50%

**67** [N13/P2/QB6/c(iii)]

(c) (iii) State the formula of aluminium sulfate. [1]

**SOLUTION**

(c) (iii)  $\text{Al}_2(\text{SO}_4)_3$

**68** [N13/P2/QB7/d]

(d) Ethanol can be manufactured by the catalytic addition of steam to ethene.  

$$\text{C}_2\text{H}_4 + \text{H}_2\text{O} \rightarrow \text{C}_2\text{H}_5\text{OH}$$
 If the reactants are not recycled, only 5% of the ethene is converted to ethanol.  
 Calculate the mass of ethanol formed from 0.4 tonnes of ethene when only 5% of the ethene is converted to ethanol.  
 [1 tonne is 1 000 000 grams] [3]

**SOLUTION**

(d) Mr of ethene=28g and Mr of ethanol=46g  
 0.4 tonnes gives  $0.4 \times (46/28)=0.657$  tonnes  
 $(5/100) \times 0.657=0.03$  tonnes ethanol

**69** [N13/P2/QB8/b(i)]

The table shows the concentrations of HI(g), H<sub>2</sub>(g) and I<sub>2</sub>(g) in the equilibrium mixture at 25 °C and 450 °C.

| substance          | concentration at 25 °C<br>/ mol / dm <sup>3</sup> | concentration at 450 °C<br>/ mol / dm <sub>3</sub> |
|--------------------|---|--|
| HI(g)              | 0.94  | 0.79   |
| H <sub>2</sub> (g) | 0.033   | 0.11   |
| I <sub>2</sub> (g) | 0.033   | 0.11   |

(b) (i) The tube has a volume of 50 cm<sup>3</sup>.  
 Calculate the mass of hydrogen iodide in the equilibrium mixture at 25 °C. [2]

**SOLUTION**

(b) (i) moles of HI =  $0.94 \times (50/1000)=0.047$  mol  
 Mass of HI =  $0.047 \times 128 = 6.0\text{g}$   
 (Moles= concentration x volume and moles= mass/Mr)

**70** [N13/P2/QB9/d]

(d) A student titrated 10.0 cm<sup>3</sup> of aqueous calcium hydroxide with hydrochloric acid.  

$$\text{Ca}(\text{OH})_2(\text{aq}) + 2\text{HCl}(\text{aq}) \rightarrow \text{CaCl}_2(\text{aq}) + 2\text{H}_2\text{O}(\text{l})$$
 It required 4.00 cm<sup>3</sup> of 0.0100 mol / dm<sup>3</sup> hydrochloric acid to neutralise 10.0 cm<sup>3</sup> of aqueous calcium hydroxide.  
 Calculate the concentration of the calcium hydroxide. [3]

**SOLUTION**

(d) Moles of HCl =  $0.01 \times (4/1000)= 4 \times 10^{-5}$

Molar ratio of HCl to  $\text{Ca(OH)}_2 = 1:2$   
 Moles of  $\text{Ca(OH)}_2 = 2 \times 10^{-5}$   
 Concentration of  $\text{Ca(OH)}_2 = (2 \times 10^{-5}/0.01) = 2 \times 10^{-3} \text{ mol / dm}^3$

**71**

**[J14/P2/QA2/a,c]**

Farmers use chemicals to improve crop yield.

Ammonium phosphate,  $(\text{NH}_4)_3\text{PO}_4$ , is used as a fertiliser and calcium hydroxide,  $\text{Ca(OH)}_2$ , is used to reduce the acidity of soils.

The relative formula mass of ammonium phosphate is 149.

(a) Calculate the percentage by mass of nitrogen in ammonium phosphate. [1]

(c) A sample of ammonium phosphate can be produced by the reaction of aqueous ammonia and phosphoric acid.

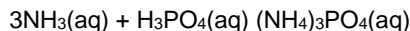

25.0 cm<sup>3</sup> of 1.25 mol / dm<sup>3</sup> phosphoric acid is neutralised by 45.3 cm<sup>3</sup> of aqueous ammonia.

(i) Calculate the concentration, in mol / dm<sup>3</sup>, of the ammonia used. [3]

(ii) Show, by calculation, that 4.66 g of ammonium phosphate would be produced. Assume that the yield is 100%.

[M<sub>r</sub>:  $(\text{NH}_4)_3\text{PO}_4$ , 149] [1]

(iii) In practice, the actual mass of ammonium phosphate produced is 2.93 g. Calculate the percentage yield of ammonium phosphate. [1]

**SOLUTION**

(a)  $[(14 \times 3)/149] \times 100 = 28.2\%$

(M<sub>r</sub> of N is 14 and ammonium phosphate contains 3 atoms of N)

(c) (i) Moles of  $\text{H}_3\text{PO}_4 = 1.25 \times (25/1000) = 0.03125 \text{ mol}$

Molar ratio of  $\text{H}_3\text{PO}_4:\text{NH}_3 = 1:3$

Moles of  $\text{NH}_3 = 0.03125 \times 3 = 0.09375$

Hence, concentration of  $\text{NH}_3 = 0.09375/0.0453 = 2.07 \text{ mol/dm}^3$

(Moles = concentration x volume)

(ii) Mass =  $0.03125 \times 149$

(Mass = moles x M<sub>r</sub>)

(iii)  $(2.93/4.66) \times 100 = 62.9\%$

(Percentage yield = (experimental yield/theoretical yield) x 100)

**72**

**[J14/P2/QB7/d(ii)]**

(d) (ii) Alkane **G** contains 84% carbon by mass.

Calculate the molecular formula for **G**. [3]

**SOLUTION**

|     |      |                    |                           |                         |
|-----|------|--------------------|---------------------------|-------------------------|
| (d) | (ii) | %age of element =  | Carbon (84%)              | Hydrogen (100-84 = 16%) |
|     |      | Moles of element = | $84/12 = 7$               | $16/1 = 16$             |
|     |      | Molecular formula: | $\text{C}_7\text{H}_{16}$ |                         |

**73**

**[J14/P2/QB8/c]**

- (c) A sample containing 0.233 g of an unknown Group I element is added to excess ethanol. The volume of hydrogen gas formed at room temperature and pressure is 400 cm<sup>3</sup>. Calculate the relative atomic mass,  $A_r$ , of the Group I element and suggest the identity of the element.  
relative atomic mass =  
identity of the element =

[4]

**SOLUTION**

- (c) Moles of hydrogen =  $400/24000 = 0.01667$   
(1 mole of a gas = 24000cm<sup>3</sup>)  
Moles of alkali metal =  $0.01667 \times 2 = 0.03334$   
 $A_r$  of alkali metal =  $0.233/0.03334 = 6.98$   
 $A_r$  of an alkali metal corresponds to Lithium

**74**

**[J14/P2/QB9/d]**

- (d) Calculate the mass of Fe<sub>3</sub>O<sub>4</sub> formed when 2.80 g of iron completely reacts with excess steam. [3]

**SOLUTION**

- (d) Moles of iron =  $2.80/56 = 0.05$   
Molar ratio of Fe:Fe<sub>3</sub>O<sub>4</sub> = 3:1  
Moles of Fe<sub>3</sub>O<sub>4</sub> =  $0.05/3 = 0.01667$  (1)  
Mass of Fe<sub>3</sub>O<sub>4</sub> =  $(0.01667 \times 232) = 3.87$  g  
[ $M_r$  of Fe<sub>3</sub>O<sub>4</sub> =  $(56 \times 3 + 16 \times 4 = 232)$ ]  
(Moles = mass/ $M_r$ )

**75**

**[N14/P2/QA3/b(ii),c]**

- (b) (ii) Calculate the concentration of chloride ions, in mol / dm<sup>3</sup>, arising from the magnesium chloride in seawater. [1]  
(c) The concentration of sulfate ions in seawater is 1.24 g / dm<sup>3</sup>. Excess aqueous barium chloride is added to a 50.0 cm<sup>3</sup> sample of seawater. Calculate the mass of barium sulfate precipitated in this reaction.  
 $Ba^{2+}(aq) + SO_4^{2-} \rightarrow (aq) BaSO_4(s)$  [3]

**SOLUTION**

- (b) (ii) Molar ratio of Cl : MgCl<sub>2</sub> :: 2 : 1  
Concentration of Cl ions =  $(1.26)2 = 2.52$ g/dm<sup>3</sup>  
Concentration of Cl ions in mol/dm<sup>3</sup> =  $2.52/96 = 0.027$  mol/dm<sup>3</sup>  
( $M_r$  of MgCl<sub>2</sub> =  $24 + 2(35.5) = 95$ )  
Concentration in mol/dm<sup>3</sup> = concentration in g/dm<sup>3</sup> divide by  $M_r$   
(c)  $96$  g SO<sub>4</sub><sup>2-</sup> →  $233$  g BaSO<sub>4</sub>  
Therefore,  $1.24$  g SO<sub>4</sub><sup>2-</sup> →  $(233/96) \times 1.24 = 3.01$  g BaSO<sub>4</sub>

**76**

**[N14/P2/QA4/b(ii)]**

The graph below shows how the pH changes when aqueous sulfuric acid is added slowly to 45.0 cm<sup>3</sup> of 0.150 mol / dm<sup>3</sup> sodium hydroxide until the acid is in excess.



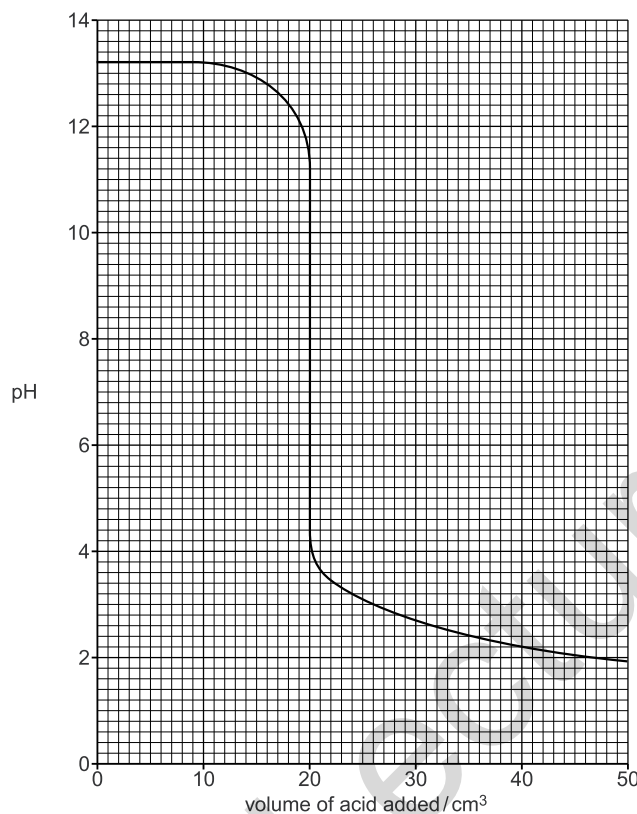

- (b) (ii) Use your answer to part (i) to calculate the concentration, in mol / dm<sup>3</sup>, of the sulfuric acid.  
concentration = mol / dm<sup>3</sup> [3]

**SOLUTION**

- (b) (ii) Moles of NaOH =  $0.15 \times 45/1000 = 0.00675$   
Moles of H<sub>2</sub>SO<sub>4</sub> =  $0.00675/2 = 0.003375$   
Concentration of H<sub>2</sub>SO<sub>4</sub> =  $0.003375 / (20/1000) = 0.17$  mol/dm<sup>3</sup>  
(Moles = concentration x volume)

**77**

**[N14/P2/QB7/e(i)]**

- (e) (i) Calculate the mass of hydrogen cyanide that can be formed from 500 g of methane if the percentage yield of hydrogen cyanide is 65%. [2]

**SOLUTION**

- (e) (i) 16 g methane → 27 g HCN  
Therefore, 500 g methane →  $(500/16) \times 27 = 843.75$  g HCN  
Experimental yield =  $0.65 \times 843.75 = 548.4$  g of HCN  
(%age yield = experimental yield/theoretical yield)

**78**

**[N14/P2/QB8/a(i,ii)]**

The ester, ethyl ethanoate, reacts with hydroxide ions to form ethanoate ions and ethanol.

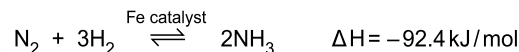

- (a) (i) Use the information in the graph to deduce the mass of ethanoate ions in 200 cm<sup>3</sup> of solution when the reaction is complete. [2]  
 (ii) Use the information in the graph to calculate the average rate of reaction, in mol / dm<sup>3</sup> / s, during the first 300 seconds. [1]

**SOLUTION**

- (a) (i) Concentration of CH<sub>3</sub>COO<sup>-</sup> ions when the reaction completes = 0.45 mol / dm<sup>3</sup>  
 Moles of CH<sub>3</sub>COO<sup>-</sup> ions in 200cm<sup>3</sup> = 0.09  
 [(0.45 × 200)/1000] = 0.09  
 Mass of CH<sub>3</sub>COO<sup>-</sup> ions in 200cm<sup>3</sup> = 0.09 × 59 = 5.31 g  
 (Moles = mass × Mr)  
 (ii) 0.17/300 = 5.67 × 10<sup>-4</sup> mol / dm<sup>3</sup> / s  
 (Rate = concentration/time)

**79**

**[N14/P2/QB9/e]**

- (e) Ammonia is used to make fertilisers such as ammonium phosphate, (NH<sub>4</sub>)<sub>3</sub>PO<sub>4</sub>. Calculate the percentage by mass of nitrogen in ammonium phosphate. [2]

**SOLUTION**

- (e) %age by mass of N in (NH<sub>4</sub>)<sub>3</sub>PO<sub>4</sub> = mass of nitrogen / total Mr of ammonium nitrate  
 (Mr of (NH<sub>4</sub>)<sub>3</sub>PO<sub>4</sub> = (14 × 3) + (12 × 1) + (16 × 4) + 31 = 149)  
 $\frac{(14)^3}{149} \times 100 = 28.2\%$

**80**

**[N15/P2/QA6]**

When one mole of sulfur burns, 247 kJ of energy is released.

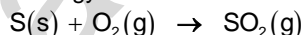

- (a) Calculate the energy released when 9.60 g of sulfur is burnt. [2]  
 (b) When sulfur dioxide is passed through aqueous sodium hydroxide, sodium hydrogensulfite is formed. Sodium hydrogensulfite contains the hydrogensulfite ion, HSO<sub>3</sub><sup>-</sup>.  
 Construct the ionic equation for this reaction. [1]  
 (c) The hydrogensulfite ion is a weaker acid than ethanoic acid.  
 Samples of 0.1 g of magnesium are added separately to 0.1 mol / dm<sup>3</sup> ethanoic acid and 0.1 mol / dm<sup>3</sup> hydrogensulfite ions.  
 Explain why the reaction is faster with ethanoic acid. [2]  
 (d) Calculate the volume of 0.10 mol / dm<sup>3</sup> sodium hydroxide which contains 3.2 g of sodium hydroxide. [2]

**SOLUTION**

- (a) Moles of sulphur =  $9.60/32 = 0.30$  mol (*Moles = mass/Mr*)  
Energy released when 9.60g or 0.30 mol burns =  $0.30 \times 247 = 74$ kJ
- (b)  $\text{NaOH}_{(aq)} + \text{SO}_{2(g)} \rightarrow \text{NaHSO}_{3(aq)}$ .  
 $\text{Na}^{+}_{(aq)} + \text{OH}^{-}_{(aq)} + \text{SO}_{2(g)} \rightarrow \text{Na}^{+}_{(aq)} + \text{HSO}_{3}^{-}_{(aq)}$ .  
 $\text{OH}^{-}_{(aq)} + \text{SO}_{2(g)} \rightarrow \text{HSO}_{3}^{-}_{(aq)}$ .
- (c) Ethanoic acid dissociates readily being the stronger acid and hence produces more  $\text{H}^{+}$  ions, this increases the collision frequency between Mg and  $\text{OH}^{-}$
- (d)  $\text{NaOH} = 3.2/40 = 0.08$  mol (*Moles = mass/Mr*)  
Volume of NaOH =  $0.08/0.10 = 0.8$ dm<sup>3</sup> = 800cm<sup>3</sup> (*Volume = moles/concentration*)

**81**

**[N15/P2/QB8/a]**

Chlorine reacts with sodium hydroxide.



- (a) A volume of 144 cm<sup>3</sup> of chlorine gas, measured at room temperature and pressure, is passed into 38.0 cm<sup>3</sup> of 0.250 mol / dm<sup>3</sup> sodium hydroxide.  
Show by calculation which reactant is in excess. [3]

**SOLUTION**

- (a) Moles of  $\text{Cl}_2 = 0.144/24 = 0.006$  mol (*Moles = vol/24dm<sup>3</sup>*)  
Moles of NaOH =  $0.250 \times 0.038 = 0.0095$  mol (*Moles = concentration x volume*)  
Moles of  $\text{Cl}_2$  required to react with 0.0095 mol NaOH =  $0.0095/2 = 0.00475$  mol  
Moles of  $\text{Cl}_2$  available = 0.006 mol, hence  $\text{Cl}_2$  is present in excess

**82**

**[J16/P2/QA2/c]**

Hydrogen fluoride, HF, has a simple molecular structure. It is soluble in water.

- (c) Dilute hydrofluoric acid reacts with aqueous calcium hydroxide.  
 $2\text{HF}(\text{aq}) + \text{Ca}(\text{OH})_2(\text{aq}) \rightarrow \text{CaF}_2(\text{aq}) + 2\text{H}_2\text{O}(\text{l})$   
What is the minimum volume, in cm<sup>3</sup>, of 0.150 mol / dm<sup>3</sup>  $\text{Ca}(\text{OH})_2$  required to react completely with a solution containing 0.200 g of HF? [3]

**SOLUTION**

- (c) Moles of HF =  $0.200/20 = 0.01$  mol  
Therefore, moles of  $\text{Ca}(\text{OH})_2 = 0.01/2 = 0.005$  moles  
Volume of  $\text{Ca}(\text{OH})_2$  required =  $0.005/0.15 = 0.033$  dm<sup>3</sup> or 33.33 cm<sup>3</sup>  
(*moles = mass/Mr*)  
*Molar ratio* → HF :  $\text{Ca}(\text{OH})_2 = 2 : 1$   
*Moles = concentration x volume*  
volume of  $\text{Ca}(\text{OH})_2(\text{aq}) = \underline{\underline{33.33}}$  cm<sup>3</sup>

**83**

**[J16/P2/QA4/d]**

Sulfuric acid is manufactured by the contact process.

- (d) Sulfuric acid is used to make the fertiliser potassium sulfate,  $\text{K}_2\text{SO}_4$ .  
Calculate the percentage by mass of potassium in this fertiliser. [2]

**SOLUTION**

(d) 
$$\frac{\text{mass of K}}{\text{mass of K}_2\text{SO}_4} = \frac{80}{(40 \times 2) + 32 + (16 \times 4)} = 44.8\%$$

**84**

**[J16/P2/QB8/d,e(i)]**

(d) Cyclohexene can be manufactured from hexane as shown in the equation.

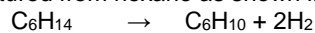

Calculate the mass of cyclohexene that can be made from 258g of hexane.

[ $M_r$  of cyclohexene = 82]

[2]

(e) Another cycloalkene has the following percentage composition by mass.

C, 88.2%; H, 11.8%

(i) Use the percentage composition by mass to show that the empirical formula of this cycloalkene is  $\text{C}_5\text{H}_8$ .

[2]

**SOLUTION**

(d) Moles of hexane =  $258/86 = 3$  mol

Molar ratio of hexane : cyclohexene :: 1 : 1

Hence, moles of cyclohexene = 3

Mass of cyclohexene =  $3 \times 82 = 246$ g

(Moles = mass/ $M_r$ )

mass of cyclohexene = **246** g

(e) (i)

|                               |           |
|-------------------------------|-----------|
| Carbon                        | Hydrogen  |
| 88.2/12                       | 11.8/1    |
| Moles=7.35                    | 11.8      |
| 7.35/7.35                     | 11.8/7.35 |
| 1                             | 1.6       |
| 1×5                           | 1.6×5     |
| 5                             | 8         |
| Hence, $\text{C}_5\text{H}_8$ |           |

Mega Lecture

## UNIT-4

## Electrolysis

### 1 [J05/P2/QA5/a]

Chlorine, hydrogen and sodium hydroxide are made by the electrolysis of concentrated aqueous sodium chloride.

- (a) Aqueous sodium chloride contains the following ions,  $\text{Na}^+$ ,  $\text{H}^+$ ,  $\text{OH}^-$  and  $\text{Cl}^-$ .  
Concentrated aqueous sodium chloride can be electrolysed using inert electrodes.  
The electrode reactions are represented below.  
Cathode  $2\text{H}^+ + 2\text{e}^- \rightarrow \text{H}_2$   
anode  $2\text{Cl}^- \rightarrow \text{Cl}_2 + 2\text{e}^-$
- (i) Explain why hydrogen, **not** sodium, is formed at the cathode.  
(ii) Suggest why, as the electrolysis proceeds, the concentration of sodium hydroxide in the electrolyte increases. [2]

#### SOLUTION

- (a) (i) Hydrogen is below sodium in the reactivity series and it is less reactive than sodium (ease of discharge)  
(*Element lower in reactivity series preferably discharges during electrolysis*)  
(ii) Chloride ions being in excess are oxidized at anode leaving  $\text{OH}^-$  in the solution

### 2 [J05/P2/QA5/d]

- (d) Describe an advantage of using hydrogen as a possible fuel in the future. [1]

#### SOLUTION

- (d) Burning of hydrogen does not produce any pollutants  
(Alternative answer: *hydrogen is a renewable source*)

### 3 [N05/P2/QB10]

A student carried out an electrolysis of dilute sulphuric acid and collected the gases formed.

- (a) Draw a labelled diagram to show the apparatus used. [2]  
(b) (i) Give the formulae of all the ions present in the solution.  
(ii) Write half equations for the reactions at the anode and cathode. Use the half equations to construct an overall equation for the reaction and give tests for any gases evolved.  
(iii) Use your equations to explain how the composition of the solution changes after the electrolysis has been running for some time. [6]  
(c) Describe another method for making hydrogen from dilute sulphuric acid. Your answer should include names of the reagents you use and an equation for the reaction. [2]

#### SOLUTION

- (a)

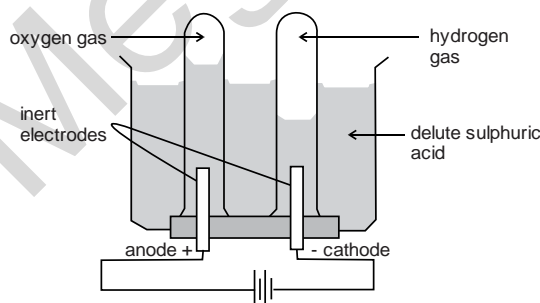

- (b) (i) Ions in sulphuric acid:  $\text{H}^+$ ,  $\text{SO}_4^{2-}$ , and  $\text{OH}^-$ .
- (ii) At cathode:  $2\text{H}^+(\text{aq}) + 2\text{e}^- \rightarrow \text{H}_2(\text{g})$ .  
At anode:  $4\text{OH}^-(\text{aq}) \rightarrow \text{O}_2(\text{g}) + 2\text{H}_2\text{O}(\text{l}) + 4\text{e}^-$ .  
Overall equation:  $2\text{H}_2\text{O}(\text{l}) \rightarrow 2\text{H}_2(\text{g}) + \text{O}_2(\text{g})$ .  
Oxygen at anode rekindles a glowing splint while hydrogen at cathode extinguishes a lighted splint with a pop sound.
- (iii) As electrolysis continues, hydrogen ions and hydroxide ions continue to be discharged at the cathode and anode respectively.  
Essentially, water molecules are split into its elements hydrogen and oxygen thus the electrolyte becomes more and more acidic.  
At the end of electrolysis, a solution of concentrated sulphuric acid is formed.
- (c) React sulphuric acid with a reactive metal. Hydrogen gas is produced  
 $\text{M} + \text{H}_2\text{SO}_4 \rightarrow \text{H}_2 + \text{MSO}_4$   
(Reactive metal such as zinc or iron can be used)

4

[J06/P2/QA1/b]

- (b) \_\_\_\_\_ is manufactured by electrolysis, [1]

**SOLUTION**

- (b) Aluminium/Sodium  
(Reactive metals above iron in the reactivity series are manufactured by electrolysis)

5

[N06/P2/QA1/a(iv)]

The diagram shows the structures of various compounds.

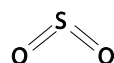

A

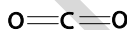

B

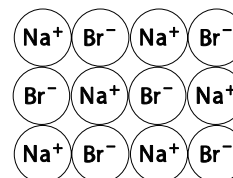

C



D

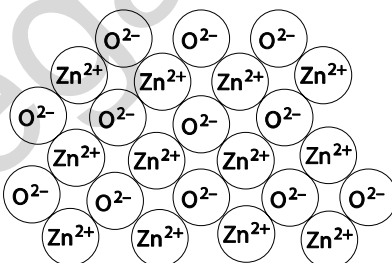

E

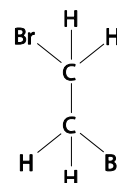

F

- (a) Use the letters A to F to answer the following.  
Each compound may be used once, more than once or not at all.

- (iv) Which **one** of these compounds when molten, releases a reddish brown gas at the anode on electrolysis?

**SOLUTION**

- (a) (iv) C  
(Br<sup>-</sup> ions oxidizes to Bromine gas on anode during electrolysis)

**6** [N06/P2/QB10/a,b,c]

The diagram shows a cell for purifying copper.

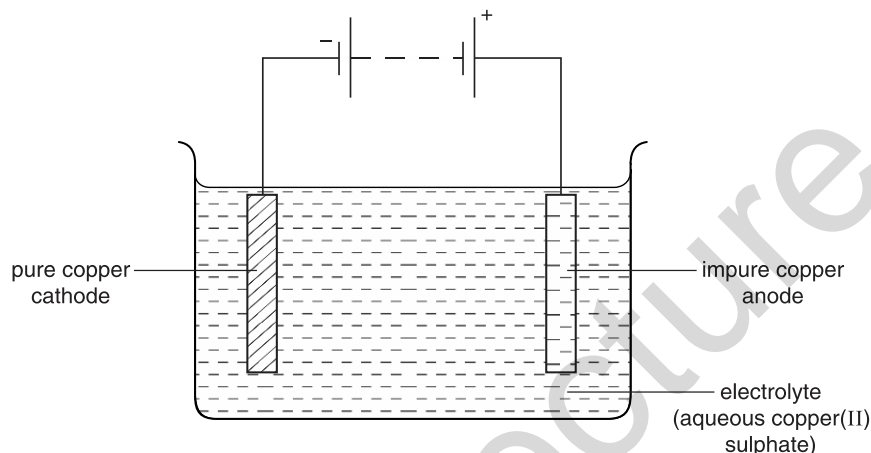

- (a) Describe what you would observe during this electrolysis and write the equations for the reactions at the electrodes. [3]
- (b) The electrodes and the electrolyte conduct electricity.  
 (i) Explain how the structure of metals allows copper electrodes to conduct electricity. [1]  
 (ii) Explain why solid copper(II) sulphate does not conduct electricity but an aqueous solution of copper(II) sulphate does conduct. [2]
- (c) Describe how the apparatus shown in the diagram could be modified in order to electroplate an iron object, such as a knife, with nickel. [2]

**SOLUTION**

- (a) Anode (impure copper electrode) decreases in thickness as solid impurities deposit below the anode as anode sludge  
 $\text{Cu} \rightarrow \text{Cu}^{2+} + 2\text{e}^-$   
 Cathode increases in size as solid, pink copper deposits on it  
 $\text{Cu}^{2+} + 2\text{e}^- \rightarrow \text{Cu}$
- (b) (i) The sea of delocalized electrons in metals helps to conduct electricity  
 (ii) Solid copper sulphate has ions in fixed position while in aqueous solutions, ions are free to move.
- (c) Iron object/knife is made the cathode while anode is made of nickel and nickel soluble salt is made the electrolyte.  
 (Examples of nickel salt: nickel nitrate, nickel sulphate, nickel chloride)

**7** [J07/P2/QA5]

- (a) Concentrated aqueous sodium chloride contains  $H^+$  and  $OH^-$  ions.  
 (i) Give the formulae of **two** other ions present in concentrated aqueous sodium chloride. [1]  
 (ii) Concentrated aqueous sodium chloride is electrolysed using inert graphite electrodes.  
 Name the product formed at each electrode.  
 product at anode  
 product at cathode [2]
- (b) Impure copper can be purified by electrolysis.  
 Draw a labelled diagram of the electrolytic cell that can be used to purify copper. [3]
- (c) Aluminium is extracted commercially from an aluminium ore by electrolysis.  
 (i) Name an ore containing aluminium. [1]  
 (ii) Name the element used as the anode in this process. [1]

**SOLUTION**

- (a) (i)  $Na^+$  and  $Cl^-$   
 ( $NaCl$  ionizes to produce  $Na^+$  and  $Cl^-$ )  
 (ii) Anode: Chlorine gas  
 Cathode: Hydrogen gas  
 (Chloride ion being negative and higher in concentration is oxidized at anode while hydrogen ions is preferably reduced at cathode)

(b)

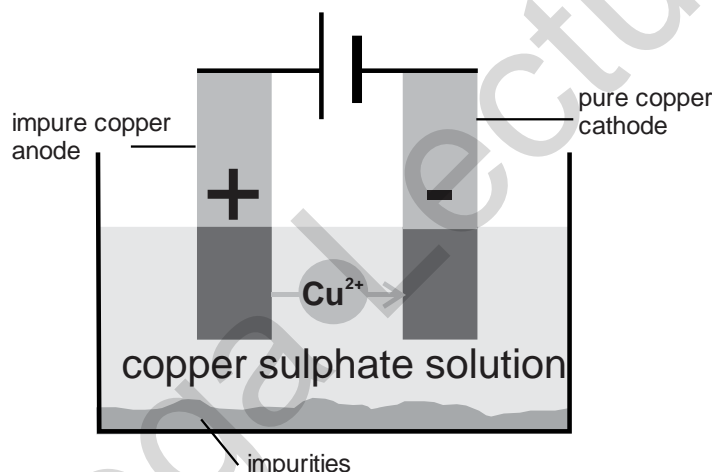

- (c) (i) Bauxite  
 (Other possible answers: Alumina/cryolite/diaspore/gibbsite/ böhmite)  
 (ii) Carbon/Graphite

**8** [N07/P2/QA1/f]

Choose from the following gases to answer the questions below.

**Ammonia**      **butane**      **carbon dioxide**      **carbon monoxide**  
**Hydrogen**      **methane**      **nitrogen**      **nitrogen dioxide**      **oxygen**

- (f) formed at the cathode when an aqueous solution of sulphuric acid is electrolysed? [1]



**SOLUTION**

- (f) Hydrogen  
(Cation ( $H^+$ ) is reduced to hydrogen at cathode)

**9** [N07/P2/QB9]

One of the first buses to use hydrogen as a fuel was operated in Erlangen, Germany, in 1996. The hydrogen was stored in thick pressurised tanks on the roof of the bus.

- (a) Describe **two** advantages of using hydrogen as a fuel rather than petrol. [2]  
 (b) Suggest one disadvantage of using hydrogen as a fuel. [1]  
 (c) Some buses use hydrogen to generate electrical energy from a fuel cell.  
 The structure of a typical fuel cell is shown.

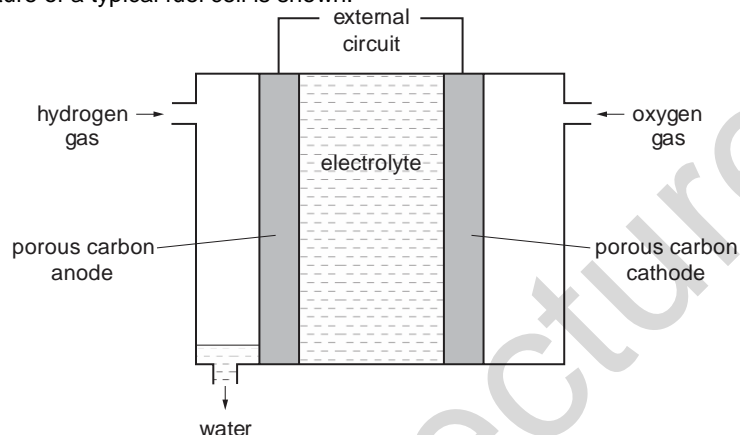

- (i) The equation for the reaction at the anode is shown.  

$$H_2(g) + 2OH^-(aq) \rightarrow 2H_2O(l) + 2e^-$$
 What type of reaction is this? Explain your answer. [1]  
 (ii) At the cathode oxygen reacts with water to form hydroxide ions. Write an ionic equation for this reaction. [1]  
 (d) In some fuel cells an acidic electrolyte is used.  
 anode reaction:  $H_2(g) \rightarrow 2H^+(aq) + 2e^-$   
 cathode reaction:  $O_2(g) + 4H^+(aq) + 4e^- \rightarrow 2H_2O(l)$   
 (i) Write an overall equation for the reaction occurring in this fuel cell. [1]  
 (ii) Suggest a suitable electrolyte for this fuel cell. [1]  
 (e) An electric current can also be generated by a simple electrochemical cell such as the one shown.

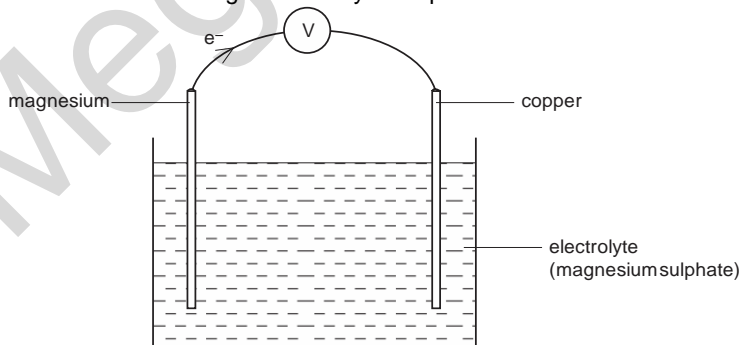

- (i) Explain why the flow of electrons is in the direction shown in the diagram. [2]  
(ii) Suggest why silver nitrate would not be a good electrolyte to use in this cell. [1]

**SOLUTION**

- (a) Hydrogen can be obtained from a renewable source such as water  
Hydrogen burns to produce only water as a product which is non polluting.  
(Other possible advantages: Larger amount of energy released per unit mass Less dense as compared to petrol)
- (b) Hydrogen is flammable or explosive  
(Other possible disadvantages: Method of storage is expensive/needs to be stored under high pressure)
- (c) (i) Oxidation because electrons are being lost and hydrogen increases its oxidation number.  
(ii)  $O_2 + 2H_2O + 4e^- \rightarrow 4OH^-$
- (d) (i)  $2H_2 + O_2 \rightarrow 2H_2O$ .  
(ii) HCl or  $H_2SO_4$
- (e) (i) Since Mg is higher than Cu in the reactivity series, it loses electrons more readily therefore electrons move from Mg to Cu.  
(ii) Mg and Cu being more reactive than silver, react with silver nitrate, displacing silver. Solid silver deposits on electrodes.  
(Other possible answer: Silver nitrate is very expensive and has lower conductivity)

**10**

**[N08/P2/QB9/a,b]**

Electrolysis can be used to remove unwanted hair. The customer holds a metal bar which acts as a positive electrode. A needle, which acts as the negative electrode, is held by the operator.

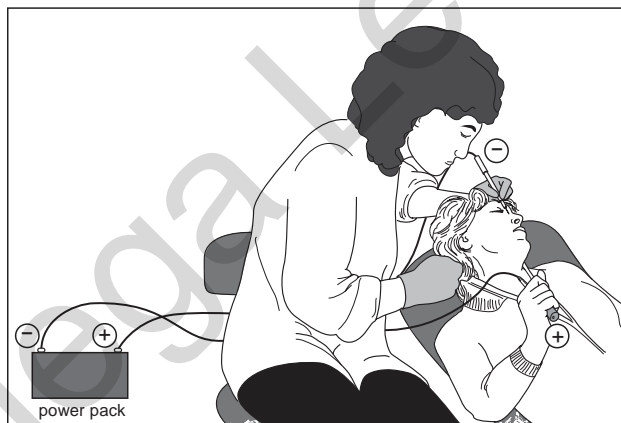

- (a) What do you understand by the term *electrolysis* ? [1]  
(b) The solution around the tip of the needle is mainly a dilute aqueous solution of sodium chloride.

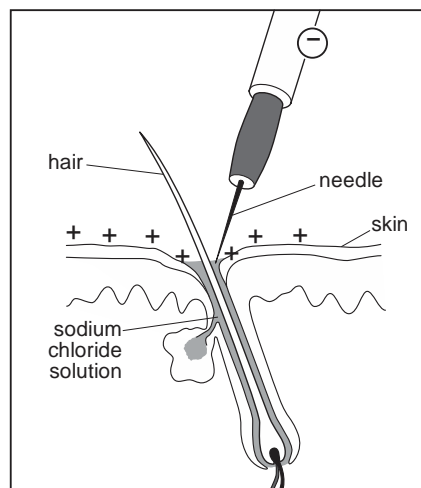

- (i) Name all the ions present in the solution during this electrolysis. [1]  
 (ii) During electrolysis a small amount of chlorine is formed at the surface of the skin. Write an ionic equation for this reaction. [1]  
 (iii) During electrolysis, a gas forms at the tip of the needle and the solution changes from pH 7 to pH 10. Explain both these changes. [2]

**SOLUTION**

- (a) Electrolysis refers to the chemical decomposition of an aqueous or molten electrolyte into its ions, which then move towards oppositely charged electrodes.  
 (b) (i) Sodium ions, chloride ions, hydrogen ions and hydroxide ions  
 (ii)  $2\text{Cl}^- \rightarrow \text{Cl}_2 + 2\text{e}^-$   
 (iii) Hydrogen ions from water change to hydrogen gas while  $\text{OH}^-$  remains in the solution making the solution alkaline and changing the pH from 7 to 10

11

[J09/P2/QA3]

Electrolysis involves the decomposition of a compound by the passage of an electric current.

- (a) (i) Complete the table, which relates to the electrolysis of different solutions using inert electrodes.

| Electrolyte                          | ions in electrolyte  | product at anode | product at cathode |
|--------------------------------------|--|------------------|--------------------|
| dilute aqueous potassium nitrate     | $\text{K}^+$ , $\text{H}^+$ , $\text{OH}^-$ and $\text{NO}_3^-$        | oxygen           | Hydrogen           |
| Concentrated aqueous sodium chloride | $\text{Na}^+$ , $\text{H}^+$ , $\text{OH}^-$ and $\text{Cl}^-$         | chlorine         | hydrogen           |
| dilute aqueous copper(II) sulfate    | $\text{Cu}^{2+}$ , $\text{SO}_4^{2-}$ , $\text{H}^+$ and $\text{OH}^-$ | .....            | .....              |
| dilute sulfuric acid                 | .....  | oxygen           | Hydrogen           |

[3]

- (ii) Explain why the electrolysis of concentrated aqueous sodium chloride liberates hydrogen rather than sodium at the cathode. [1]
- (iii) The electrolysis of **dilute** aqueous sodium chloride liberates oxygen at the anode. Suggest why the electrolysis of **concentrated** aqueous sodium chloride liberates chlorine rather than oxygen. [1]
- (b) Aqueous copper(II) sulfate was electrolysed using copper electrodes. The copper anode lost mass as copper(II) ions were formed and the copper cathode gained mass as copper atoms were formed.
- (i) State one industrial application of this electrolysis. [1]
- (ii) The results of an experiment involving the electrolysis of aqueous copper(II) sulfate are shown below.

| temperature of electrolyte / °C | current used / amps | time of electrolysis / s | mass of copper formed at the cathode / g |
|---------------------------------|---------------------|--------------------------|--|
| 20                              | 1.0                 | 1000                     | 0.329                                    |
| 20                              | 2.0                 | 1000                     | 0.658                                    |
| 20                              | 2.0                 | 2000                     | 1.320                                    |
| 25                              | 2.0                 | 2000                     | 1.320                                    |
| 30                              | 1.0                 | 1000                     | 0.329                                    |

Use the information in the table to describe how each of the variables affects the mass of copper formed at the cathode.

temperature  
current  
time

[3]

### SOLUTION

- (a) (i)

| Electrolyte                          | Ions in electrolyte   | Product at anode | Product at cathode |
|--------------------------------------|---|------------------|--------------------|
| dilute aqueous potassium nitrate     | $K^+$ , $H^+$ , $OH^-$ and $NO_3^-$                                   | oxygen           | hydrogen           |
| concentrated aqueous sodium chloride | $Na^+$ , $H^+$ , $OH^-$ and $Cl^-$                                    | chlorine         | hydrogen           |
| dilute aqueous copper(II) sulfate    | $Cu^{2+}$ , $SO_4^{2-}$ , $H^+$ and $OH^-$                            | <b>oxygen</b>    | <b>copper</b>      |
| dilute sulfuric acid                 | <b><math>H^+</math>, <math>OH^-</math> and <math>SO_4^{2-}</math></b> | oxygen           | hydrogen           |

- (ii) Hydrogen ions has a lower position in reactivity series than sodium and hence hydrogen ions are easier to reduce (Reduction takes place on cathode)
- (iii) Chloride ion concentration is greater than hydroxide ion concentration therefore chloride ion has a greater chance to discharge at anode
- (b) (i) Purification of copper
- (ii) **Temperature:** no effect  
**Current:** increasing the current increases the mass of copper deposited  
**Time:** increasing the time increases the mass of copper deposited

12

[N09/P2/QB7/a,b]

Copper is purified by the electrolysis of aqueous copper(II) sulfate using copper electrodes.

- (a) Explain how this process is carried out in the laboratory and give relevant equations for the electrode reactions. [4]
- (b) Aqueous copper(II) sulfate can also be electrolysed using carbon electrodes. [1]
- (i) Write an equation for the reaction which takes place at the anode in this electrolysis. [1]
- (ii) Explain why the colour of the copper(II) sulfate solution fades during this electrolysis. [1]

**SOLUTION**

- (a) Aqueous copper (II) sulphate (electrolyte) is taken in a beaker. Impure copper is made anode and pure copper is made as cathode. Electrodes are dipped into the electrolyte and the battery is connected to them. Pure copper atoms from the electrolyte deposit at cathode and copper ions from the anode dissolve in the electrolyte. The process is continued until whole anode is used up.  
Reaction at cathode:  $\text{Cu}^{2+} + 2\text{e}^- \rightarrow \text{Cu}$ .  
Reaction at anode:  $\text{Cu} \rightarrow \text{Cu}^{2+} + 2\text{e}^-$   
(Reduction takes place at cathode while oxidation takes place at anode)
- (b) (i)  $4\text{OH}^- \rightarrow 2\text{H}_2\text{O} + \text{O}_2 + 4\text{e}^-$ .  
(ii) As copper (II) ions are reduced at cathode, the concentration of copper (II) ions decreases and the color fades away.

**13**

**[J10/P2/QA4]**

The electrical conductivity of a substance is related to its structure and bonding.

- (a) Graphite and diamond are both forms of solid carbon. Explain why graphite conducts electricity but diamond does not. [2]
- (b) Explain why solid sodium chloride does not conduct electricity whereas aqueous sodium chloride does conduct electricity. [2]
- (c) Complete the following table about electrolysis using inert graphite electrodes.

| Electrolyte                | product at cathode | product at anode |
|----------------------------|--------------------|------------------|
| molten lead(II) bromide    |                    |                  |
| aqueous copper(II) sulfate | copper             |                  |
| dilute sulfuric acid       |                    | Oxygen           |

- (d) Describe one commercial use of electrolysis. [3]  
Use electrolyte used ionic equation for reaction at the cathode [3]

**SOLUTION**

- (a) Graphite has mobile electrons which help in conducting electricity while diamond does not have mobile electrons.  
In graphite, each carbon atom is covalently bonded to 3 other carbon atoms while in diamond, each carbon is covalently bonded to four other carbon atoms.
- (b) Solid sodium chloride has ions fixed in position while aqueous sodium chloride has ions which are mobile/free to move about.  
Ionic compounds can only conduct electricity in molten or aqueous state due to the availability of mobile ions.

(c)

| Electrolyte                | product at cathode | product at anode |
|----------------------------|--------------------|------------------|
| molten lead(II) bromide    | lead               | bromine          |
| aqueous copper(II) sulfate | copper             | oxygen           |
| dilute sulfuric acid       | hydrogen           | oxygen           |

Molten lead (II) bromide: It has only two ions;  $\text{Pb}^{2+}$  and  $\text{Br}^-$ .  $\text{Pb}^{2+}$  is reduced on cathode while  $\text{Br}^-$  is oxidised on anode.

Aqueous copper (II) sulfate: It has four ions;  $\text{H}^+$ ,  $\text{Cu}^{2+}$ ,  $\text{OH}^-$  and  $\text{SO}_4^{2-}$ .  $\text{Cu}^{2+}$  is preferably reduced on cathode while  $\text{OH}^-$  is preferably oxidised on anode producing oxygen.

Dilute sulfuric acid: It has three ions;  $\text{H}^+$ ,  $\text{OH}^-$  and  $\text{SO}_4^{2-}$ .  $\text{H}^+$  is reduced on cathode while  $\text{OH}^-$  is preferably oxidised on anode producing oxygen.

(d) Use: extraction of aluminium.

Electrolyte use: Molten aluminium oxide dissolved in cryolite.

Ionic equation for reaction at cathode:  $\text{Al}^{3+} + 3\text{e}^- \rightarrow \text{Al}$

Other commercial uses: production of  $\text{NaOH}$ , electroplating, purification of copper.

14

[N10/P2/QB7/a,b,c]

Zinc chloride is an ionic solid. It can be electrolysed using the apparatus shown below.

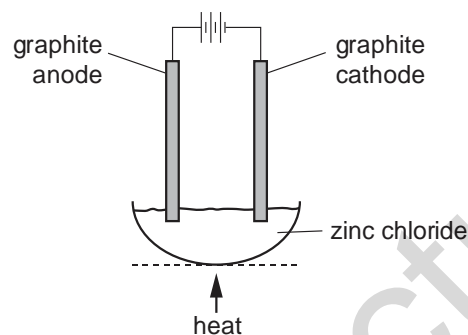

- (a) Explain why zinc chloride conducts electricity when molten, but not when solid. [2]
- (b) Predict the products of this electrolysis at the anode, the cathode. [1]
- (c) When a dilute aqueous solution of zinc chloride is electrolysed, hydroxide ions are converted to oxygen at the anode. Write the ionic equation for this reaction. [2]

**SOLUTION**

- (a) In molten state, ions are free to move while in solid state, ions are **held** in fixed positions-unable to move.
- (b) **The anode:** Chlorine gas  
**The cathode:** Zinc metal  
Anion discharges at anode while cation discharges at cathode
- (c)  $4\text{OH}^- \rightarrow \text{O}_2 + 2\text{H}_2\text{O} + 4\text{e}^-$

15

[J11/P2/QB9/b(ii)]

- (b) (ii) Describe how impure copper can be purified. [2]

**SOLUTION**

- (b) (ii) It can be purified by electrolysis of aq.  $\text{CuSO}_4$  where impure copper is made the anode, pure copper is made the cathode. When the current is passed, copper from anode dissolves in electrolyte and copper ions deposit at cathode

16

[N11/P2/QA1/e]

Choose from the following list of elements to answer the questions below.

Calcium            chlorine            hydrogen            iodine  
Nickel            Sodium            vanadium            zinc

Each element can be used once, more than once, or not at all.

Which element

(e) is formed at the cathode when a dilute aqueous solution of sodium chloride is electrolysed, [1]

**SOLUTION**

(e) Hydrogen  
*H<sup>+</sup> and Na<sup>+</sup> are the cations present in dilute sodium chloride. On electrolysis, H<sup>+</sup> ions are preferably discharged at cathode*

17

[N11/P2/QB7/b,c]

(b) Compare and explain the difference in the electrical conductivity between a strong and a weak acid. [1]

(c) A dilute solution of sulfuric acid contains hydrogen ions, hydroxide ions and sulfate ions. When this solution is electrolysed, hydrogen gas is formed at the cathode and oxygen gas is formed at the anode.

(i) Explain why hydrogen is formed at the cathode. [1]

(ii) Write the ionic equation for the reaction at the anode. [2]

**SOLUTION**

(b) Strong acid produces more H<sup>+</sup> ions and hence shows better conductivity.  
*(Mobile ions conduct electricity)*

(c) (i) Hydrogen ions are cations (positively charged) and hence move towards cathode (negative electrode) where they are reduced to form hydrogen gas

(ii)  $4\text{OH}^- \rightarrow \text{O}_2 + 2\text{H}_2\text{O} + 4\text{e}^-$

18

[J12/P2/QA1/b]

(b) is attracted to the cathode during electrolysis, [1]

**SOLUTION**

(b) K<sup>+</sup>/Mg<sup>2+</sup>  
*(Cations are attracted towards cathode during electrolysis)*

19

[N12/P2/QA5/a(ii,iii),b,c]

Nickel can be refined by reacting the impure metal with carbon monoxide. The impurities do not react with carbon monoxide.

A volatile compound called nickel carbonyl is formed.

This is decomposed to give pure nickel and carbon monoxide.

(a) (ii) Suggest how nickel carbonyl might be decomposed. [1]

(iii) Explain how this method separates nickel from its impurities. [1]

(b) Nickel carbonyl has the formula Ni(CO)<sub>x</sub>.  
The relative molecular mass of nickel carbonyl is 171.  
Calculate the value of x. [1]

- (c) Nickel is refined by electrolysis in a similar way to copper.  
Draw a labelled diagram of the apparatus you would use to purify nickel by electrolysis in the laboratory. [4]

**SOLUTION**

- (a) (ii) By providing high temperature  
(iii) Nickel carbonyl being volatile, evaporates leaving behind the solid impurities
- (b)  $M_r$  of  $Ni(CO)_x = 171$   
 $59 + (12+16)x = 171$   
 $M_r$  of  $(CO)_x = 171 - 59 = 112$   
 $(12+16)x = (28)x = 112$   
 $x = 112/28 = 4$

- (c)

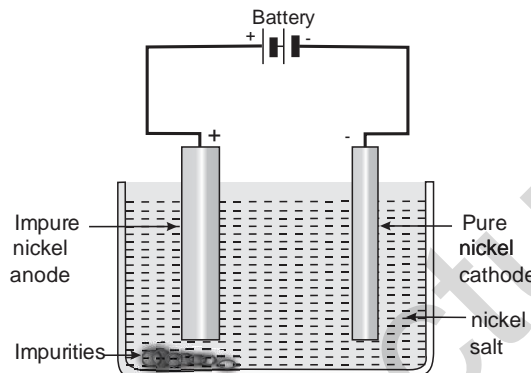

(nickel nitrate)

**20 [J13/P2/QB10/b]**

- (b) (i) Explain why pure sodium chloride can be electrolysed at 1000 °C but not at 600 °C.[2]  
 (ii) Construct an equation for the anode reaction in the electrolysis of pure sodium chloride at 1000 °C. [1]

**SOLUTION**

- (b) (i) At 600 °C, NaCl is a solid so the ions are held in fixed position and cannot move. At 1000°C, NaCl melts and the ions are free to move.  
 (ii)  $2Cl^- \rightarrow Cl_2 + 2e^-$   
 (Anode, the positive electrode attracts anions towards it)

**21 [N13/P2/QA1/a]**

Choose from the following elements to answer the questions below.

|                 |                 |                  |                |               |
|-----------------|-----------------|------------------|----------------|---------------|
| <b>Chlorine</b> | <b>hydrogen</b> | <b>iron</b>      | <b>lithium</b> | <b>nickel</b> |
| <b>Nitrogen</b> | <b>oxygen</b>   | <b>potassium</b> | <b>silver</b>  | <b>sulfur</b> |
| <b>Vanadium</b> | <b>zinc</b>     |                  |                |               |

Each element can be used once, more than once or not at all.  
Which element

- (a) is liberated at the anode when an aqueous solution of potassium sulfate is electrolysed, [1]



**SOLUTION**

- (a) Oxygen  
 $(4\text{OH}^-_{(\text{aq})} \rightarrow \text{O}_{2(\text{g})} + 2\text{H}_2\text{O}_{(\text{l})} + 4\text{e}^-)$

**22** [N13/P2/QB6/a]

Choose from the following elements to answer the questions below.

Chlorine            hydrogen            iron            lithium            nickel            nitrogen  
 Oxygen            potassium            silver            sulfur            vanadium            zinc

Each element can be used once, more than once or not at all.  
 Which element

- (a) Describe how this electrolysis is carried out and construct equations for the reactions occurring at both the anode and cathode. [4]

**SOLUTION**

- (a) Bauxite is purified to form aluminium oxide which is used as an electrolyte in the process. Electrolyte should be molten to conduct electricity but aluminium oxide has a very high melting point (above 2000 °C). So it is dissolved in molten cryolite which lowers the melting point of aluminium around 900 °C. The electrodes are made up of carbon.  
 The following reactions take place at the electrodes;  
 Anode reaction:  $2\text{O}^{2-} \rightarrow \text{O}_2 + 4\text{e}^-$   
 Cathode reaction:  $\text{Al}^{3+} + 3\text{e}^- \rightarrow \text{Al}$   
 The oxygen produced reacts with carbon anodes to produce  $\text{CO}_2$  and hence the anodes (of graphite) have to be replaced regularly

**23** [J14/P2/QA4]

Only liquids that contain moving ions can be electrolysed. These liquids are called electrolytes.

- (a) Complete the following table which shows the products formed when some liquids are

| electrolyte                          | ions present in electrolyte  | product formed at the positive electrode | product formed at the negative electrode |
|--------------------------------------|--|--|--|
| aqueous copper(II) sulfate           | $\text{Cu}^{2+}$ , $\text{H}^+$ , $\text{OH}^-$ and $\text{SO}_4^{2-}$ | .....                                    | .....                                    |
| concentrated aqueous sodium chloride | $\text{H}^+$ , $\text{Na}^+$ , $\text{Cl}^-$ and $\text{OH}^-$         | chlorine                                 | Hydrogen                                 |
| molten lead(II) bromide              | $\text{Pb}^{2+}$ and $\text{Br}^-$                                     | .....                                    | .....                                    |

- (b) When concentrated aqueous sodium chloride is electrolysed, chlorine is formed at the positive electrode (anode) and hydrogen at the negative electrode (cathode). [3]  
 (i) Construct the ionic equation to show the formation of chlorine at the positive electrode. [1]  
 (ii) Explain why hydrogen is formed at the negative electrode rather than sodium. [1]  
 (c) Name a metal manufactured by the electrolysis of a molten ionic compound. [1]

**SOLUTION**

(a)

| electrolyte                          | ions present in electrolyte  | product formed at the positive electrode | product formed at the negative electrode |
|--------------------------------------|--|--|--|
| aqueous copper(II) sulfate           | $\text{Cu}^{2+}$ , $\text{H}^+$ , $\text{OH}^-$ and $\text{SO}_4^{2-}$ | <b>oxygen</b>                            | <b>copper</b>                            |
| concentrated aqueous sodium chloride | $\text{H}^+$ , $\text{Na}^+$ , $\text{Cl}^-$ and $\text{OH}^-$         | chlorine                                 | hydrogen                                 |
| molten lead(II) bromide              | $\text{Pb}^{2+}$ and $\text{Br}^-$                                     | <b>bromine</b>                           | <b>lead</b>                              |

- (b) (i)  $2\text{Cl}^- \rightarrow \text{Cl}_2 + 2\text{e}^-$ .  
 (ii) Hydrogen is lower than sodium in the reactivity series and hence forms at the negative electrode.  
 (Hydrogen is less reactive than sodium)
- (c) Aluminium (Other possible answers: Calcium / Sodium / Potassium / Lithium / Barium / Magnesium  
 Reactive metals above iron in the reactivity series are manufactured by electrolysis)

**24** **[N14/P2/QA5/b,c]**

- (b) A simple electrochemical cell contains two electrodes in an electrolyte.  
 (i) Complete the diagram below to show how you could measure the voltage between the two different metal electrodes X and Y.

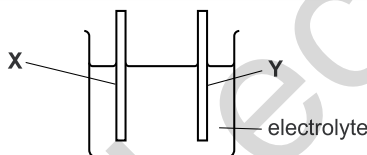

- (ii) The order of reactivity of some metals is shown below. [1]

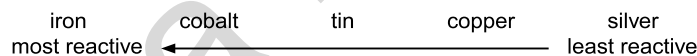

Which combination of metals from this list would produce the highest voltage when used as electrodes in an electrochemical cell? [1]

- (c) Strips of zinc can be attached to the hull of a ship to stop the steel from rusting. [1]  
 Explain how these strips of zinc stop the steel from rusting. [2]

**SOLUTION**

(b) (i)

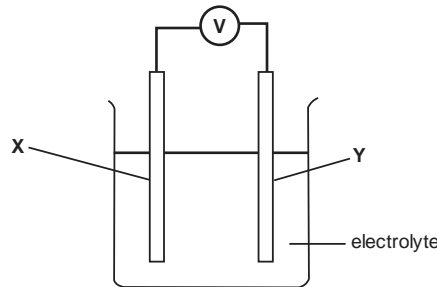

(ii) Iron and silver  
(Highest difference in electric potential)

(c) Since zinc is more reactive than iron, it corrodes and loses electrons in preference to the iron.  
(The process is termed as sacrificial protection)

**25**

**[N14/P2/QB6/d]**

(d) The electrode reactions occurring when molten sodium chloride is electrolysed are shown below.

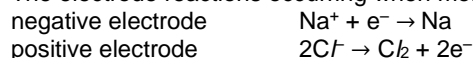

Refer to these equations to explain why this electrolysis involves both oxidation and reduction.[2]

**SOLUTION**

(d) At cathode, reduction takes place where sodium ions gain electrons.  
At anode oxidation takes place where chloride ions lose electrons

**26**

**[J15/P2/QA5]**

Electrolysis is often used in the extraction and purification of elements.

(a) Magnesium is manufactured by the electrolysis of molten magnesium chloride.  
Write equations for the two electrode reactions that occur during this electrolysis. [2]

(b) Copper can be purified using the electrolysis of aqueous copper(II) sulfate.  
(i) What is used as the anode (positive electrode)? [1]  
(ii) What is used as the cathode (negative electrode)? [1]

(c) Chlorine can be made by the electrolysis of concentrated aqueous sodium chloride.  
The overall process can be represented by the following equation.

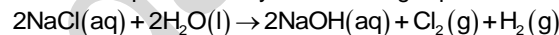

55 dm<sup>3</sup> of 3.5 mol / dm<sup>3</sup> aqueous sodium chloride is electrolysed.  
What is the maximum volume of chlorine that can be formed, measured at room temperature and pressure? [3]

**SOLUTION**

(a)  $\text{Mg}^{2+} + 2\text{e}^- \rightarrow \text{Mg}$ . (cations always get reduced on the negative electrode; cathode)  
 $2\text{Cl}^- \rightarrow \text{Cl}_2 + 2\text{e}^-$ . (anions always get oxidized on the positive electrode; anode)

(b) (i) **Impure copper**  
(ii) **Pure copper**

(c) Moles of NaCl<sub>(aq)</sub>: concentration x volume = 55 x 3.5 = 192.5 mol  
Moles of Cl<sub>2</sub> = 192.5/2 = 96.3 mol  
Volume of Cl<sub>2</sub> = moles x 24dm<sup>3</sup> = 96.3 x 24 = 2311 dm<sup>3</sup>

**27**

**[J16/P2/QB7/c]**

The formula of lead(II) nitrate is  $\text{Pb}(\text{NO}_3)_2$ .

(c) Aqueous lead(II) nitrate is electrolysed using graphite electrodes. Bubbles of colourless gas are formed at both electrodes.

(i) Identify the gas formed at each electrode.

negative electrode (cathode)

positive electrode (anode)

[2]

(ii) Construct the equation for the reaction at the cathode.

[1]

**SOLUTION**

(c) (i) negative electrode (cathode) hydrogen

positive electrode (anode) oxygen

*(hydrogen ions reduce at cathode while hydroxide ions oxidize at anode)*

(ii)  $2\text{H}^+ + 2\text{e}^- \rightarrow \text{H}_2$ .

Mega Lecture

## UNIT-5

## Energy From Chemicals

**1** [J05/P2/QB7/c(i)]

- (c) (i) In terms of the energy changes that take place during bond breaking and bond making, explain why this reaction is exothermic.

### SOLUTION

- (c) (i) Bond breaking is endothermic (absorbs energy) and bond forming is exothermic (releases energy)  
In this reaction more energy is released than absorbed so the overall reaction is exothermic.

**2** [N06/P2/QA6/e]

- (e) In the presence of light methane reacts with chlorine.

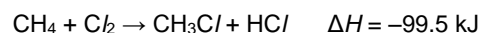

Draw an energy profile diagram for this reaction.

Show:

- the reactants and products,
- the activation energy,
- the enthalpy change.

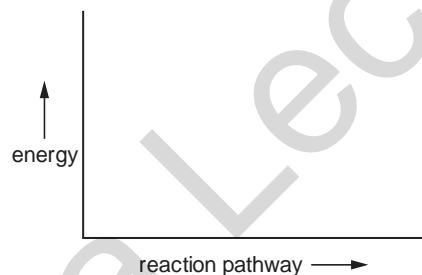

### SOLUTION

- (e)

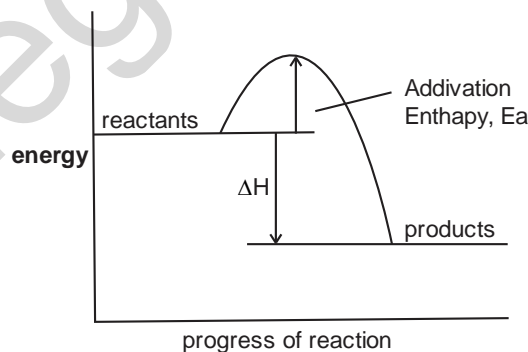

[3]

3

[J07/P2/QB10/a,b,c(i)]

Oxides of nitrogen are atmospheric pollutants. Nitrogen monoxide, NO, is formed in an internal combustion engine when nitrogen and oxygen react together.

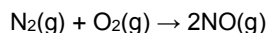

The diagram shows the energy profile for this reaction.

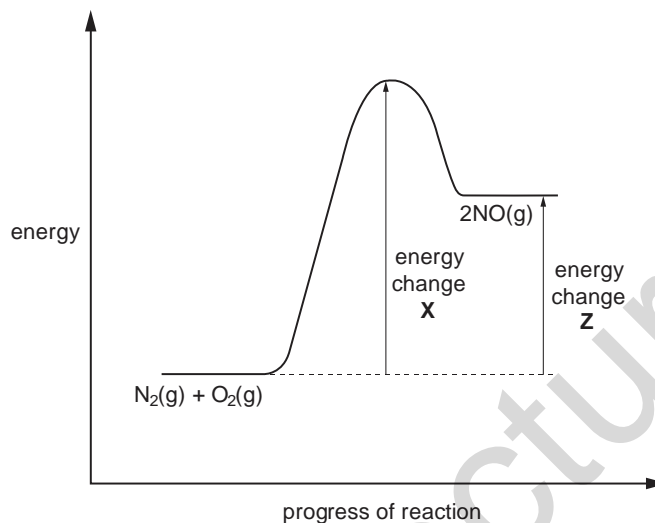

- (a) Identify the energy changes **X** and **Z**. [2]  
 (b) The reaction between nitrogen and oxygen is endothermic. [1]  
 (i) Explain how you can tell from the diagram that the reaction is endothermic. [1]  
 (ii) Explain, using ideas about bond breaking and bond making, why the overall reaction is endothermic. [3]  
 (c) (i) Explain how the catalyst in the converter increases the rate of this reaction. [1]

**SOLUTION**

- (a) **X** = Activation energy  
**Z** = enthalpy change of reaction  
 (Activation energy is the minimum amount of energy required by reactants to start the reaction while enthalpy change of reaction is the energy difference between the reactants and the products)
- (b) (i) Energy profile diagram of this reaction shows that the products have more energy than the reactants  
 (Other possible answer: Enthalpy change is positive)  
 (ii) The process of bond breaking is endothermic while the process of bond formation is exothermic. As more energy is absorbed in bond breaking than the energy released in bond forming, hence the overall reaction is endothermic.
- (c) (i) Catalyst provides a faster alternative reaction route by lowering down the activation energy of the reaction.

4

[J08/P2/QA6/c]

- (c) Sulphur dioxide and nitrogen dioxide react together as shown in the equation.



Draw an energy profile diagram for this reaction.

Indicate both the enthalpy change and the activation energy on your diagram.



**SOLUTION**

- (c)

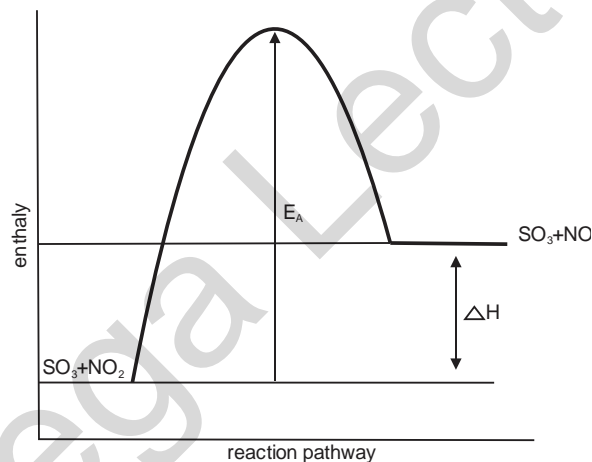

5

[N08/P2/QA2/f]

- (f) Explain, in terms of the energy changes taking place in both bond-making and bondbreaking, why the reaction is exothermic. [2]

**SOLUTION**

- (f) Bond formation releases energy while bond breaking absorbs energy. In this reaction, more energy is released while bond formation than the energy absorbed in bond breaking.

6

[N08/P2/QB7/a]

Ammonia is made by the Haber process using an iron catalyst.



- (a) On the same axes draw energy profile diagrams to show both the catalysed and the uncatalysed reaction. Label the diagram to show
- the catalysed and uncatalysed reactions,
  - the reactants and products,
  - the enthalpy change for the reaction.
- [3]

**SOLUTION**

(a)

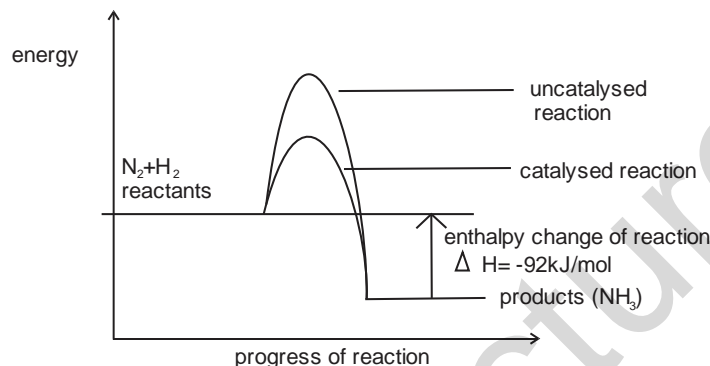

(A catalysed reaction has lower activation energy than an uncatalysed reaction in an exothermic reaction, the energy of the product is lower than the energy of the reactants enthalpy change of reaction is the difference of energies of reactants and products)

7

[J10/P2/QB7b,c]

- (b) Explain, in terms of the energy changes which occur during bond breaking and bond forming, why the combustion of hydrazine is exothermic. [2]
- (c) (i) Calculate the volume of oxygen, measured at room temperature and pressure, needed to completely combust 1.00 tonne of hydrazine. [3]  
[One tonne is  $10^6$  grams. One mole of any gas at room temperature and pressure occupies a volume of  $24 \text{ dm}^3$ .]
- (ii) A rocket burns hydrazine in an atmosphere of oxygen. Both hydrazine and oxygen are stored in the rocket as liquids. Suggest why oxygen is stored as a liquid rather than as a gas. [1]

**SOLUTION**

- (b) Bond breaking is an endothermic process while bond making is an exothermic process. In combustion of hydrazine, more energy is released during bond making and less energy is absorbed during bond breaking.
- (c) (i) Moles of  $\text{N}_2\text{H}_4 = \frac{\text{Mass in grams}}{\text{Mr of } \text{N}_2\text{H}_4} = \frac{1000000}{32} = 31\,250 \text{ mol}$   
According to the equation molar ratio of  $\text{N}_2\text{H}_4 : \text{O}_2 = 1 : 1$   
Volume of  $\text{O}_2 = \text{Moles of } \text{O}_2 \times 24 \text{ dm}^3 = 31\,250 \times 24 = 750\,000 \text{ dm}^3$



- (ii) Oxygen in liquid state occupies lesser space. This allows maximum storage capacity.

**8** [J11/P2/QB7/a,b]

Nitric oxide, NO, is an atmospheric pollutant formed inside car engines by the reaction between nitrogen and oxygen.

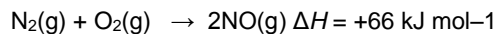

This reaction is endothermic.

- (a) Explain the meaning of the term *endothermic*. [1]  
 (b) Complete the energy profile diagram for the reaction between nitrogen and oxygen. On your diagram label the product, activation energy,  $E_a$ , enthalpy change for the reaction,  $\Delta H$ .

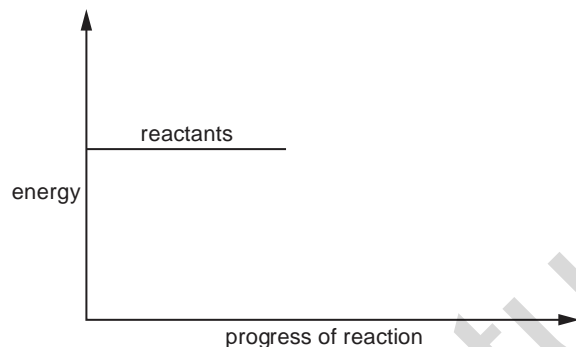

[3]

**SOLUTION**

- (a) Endothermic refers to a system which absorbs energy from the surroundings  
 (b)

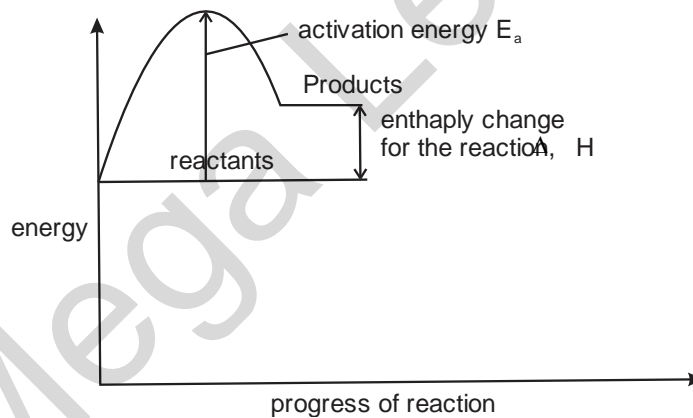

**9** [N11/P2/QA4/a(i)]

Coal is largely carbon.

- (a) Carbon burns in excess air to form carbon dioxide.  

$$\text{C}(\text{s}) + \text{O}_2(\text{g}) \rightarrow \text{CO}_2(\text{g}) \quad \Delta H = -393.5 \text{ kJ / mol}$$
  
 (i) Draw an energy profile diagram for this reaction on the axes below. On your diagram label the reactants and products

- the enthalpy change for the reaction
- the activation energy

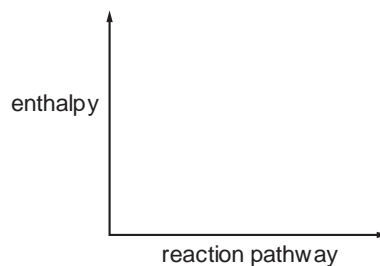

[3]

**SOLUTION**

(a) (i)

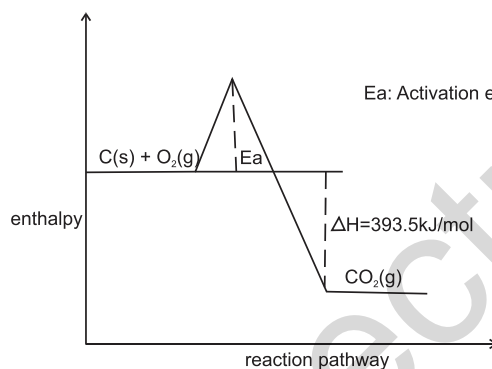

**10**

[J12/P2/QB6/a,b,e]

Hydrogen-oxygen fuel cells are used to generate electricity.  
The overall reaction in a hydrogen-oxygen fuel cell is shown below.

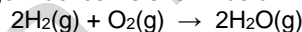

This reaction is exothermic.

- (a) Explain the meaning of the term *exothermic*. [1]
- (b) Explain, in terms of the energy changes associated with bond breaking and bond forming, why the reaction is exothermic. [2]
- (e) Name one source of the hydrogen needed for a fuel-cell. [1]

**SOLUTION**

- (a) An exothermic reaction refer to a system which releases heat energy to the surroundings.
- (b) Bond breaking takes in energy and bond forming releases energy. This reaction is exothermic because more energy is released in bond forming than energy absorbed in bond breaking.
- (e) Water/hydrocarbons  
Advantage: The hydrogen-oxygen fuel cell directly converts chemical energy into electrical an energy.  
(Other advantages: Fuel cell is more energy efficient, makes no pollutants and uses a renewable resource to provide energy)  
Disadvantage: Storage problems are associated with hydrogen and oxygen as hydrogen is highly

flammable.

(Other disadvantages: pressurized tanks are needed. There are pollution problems on disposal of fuel cell and pollution problems while manufacturing fuel cells)

**11**

**[N12/P2/QA3/b(ii)]**

**(b) (ii)** Draw a labelled enthalpy profile diagram for the overall reaction.

- On your diagram include
- the enthalpy change of reaction,
  - the activation energy,
  - reactants,
  - products.

[3]

**SOLUTION**

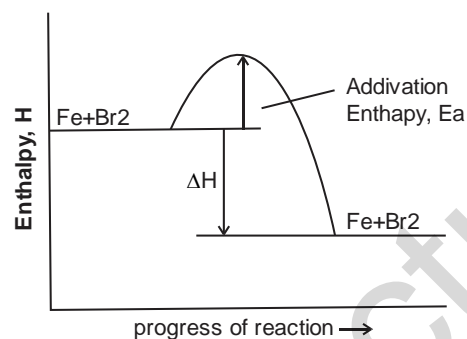

**12**

**[J13/P2/QA2/c]**

**(c)** Respiration is an exothermic reaction.

**(i)** Explain, in terms of the energy changes that occur during bond breaking and bond making, why respiration is an exothermic reaction. [2]

**(ii)** Complete the energy profile diagram for respiration.

- On your diagram label the
- products,
  - enthalpy change for the reaction,  $\Delta H$ ,
  - activation energy,  $E_a$ .

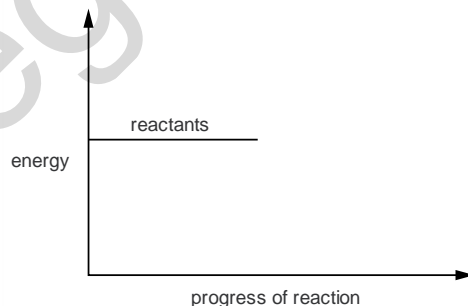

[3]

**SOLUTION**

- (c) (i) Bond breaking absorbs energy (endothermic) while bond formation releases energy (exothermic). In respiration, more energy is released in bond formation than less energy is absorbed in bond breaking hence it is an exothermic reaction.

(ii)

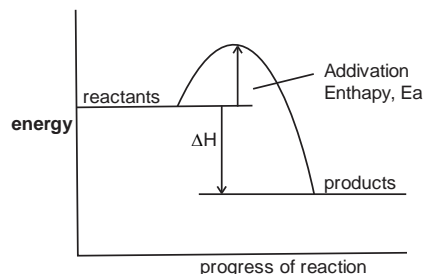

**13**

**[J13/P2/QB9/a(ii)]**

Methane reacts with water to produce hydrogen and carbon monoxide.

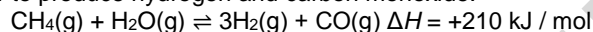

This reaction is endothermic.

The reaction is normally carried out at a pressure of 30 atmospheres and a temperature of 850 °C.

- (a) The reaction is carried out at 30 atmospheres pressure and at **600 °C** rather than 850 °C.

Predict and explain the effect of lowering the temperature on

- (ii) the position of equilibrium.

[2]

**SOLUTION**

- (a) (ii) Since the reaction is endothermic, lowering the temperature shifts the equilibrium to the left side which is exothermic (lowering the temperature shifts the equilibrium to the side which releases heat)

**14**

**[N13/P2/QB8/c]**

- (c) Complete the energy profile diagram for the decomposition of hydrogen iodide.

On your diagram label

- the products,
- the enthalpy change of the reaction,  $\Delta H$ .

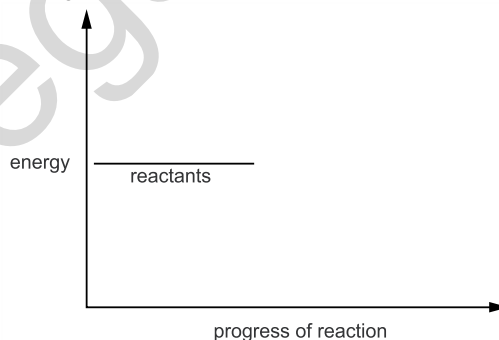

[2]

**SOLUTION**

(c)

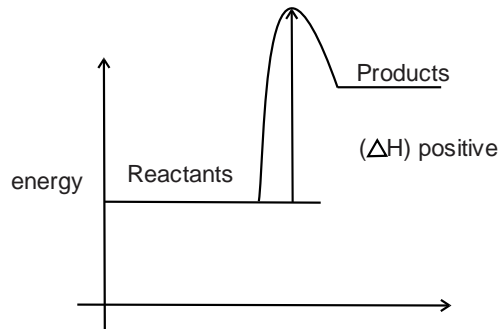

**15**

[J14/P2/QB9/a]

Choose from the following gases to answer the questions below.

CCl<sub>4</sub>      CH<sub>4</sub>      CO      CO<sub>2</sub>      H<sub>2</sub>  
N<sub>2</sub>      NH<sub>3</sub>      O<sub>2</sub>      SO<sub>2</sub>

Each gas can be used once, more than once or not at all.

Which gas is

(a) The forward reaction is endothermic. What is the meaning of the term *endothermic*? [1]

**SOLUTION**

(a) Endothermic refers to heat energy being absorbed

**16**

[N14/P2/QA2/b(iii)]

The table shows some properties of the Group I metals.

| metal     | density<br>in g / cm <sup>3</sup> | melting point<br>/ °C | boiling point<br>/ °C |
|-----------|-----------------------------------|-----------------------|-----------------------|
| lithium   | 0.53                              | 181                   | 1342                  |
| sodium    | 0.97                              | 98                    | 883                   |
| potassium | 0.86                              | 63                    |                       |
| rubidium  | 1.53                              | 39                    | 686                   |
| caesium   | 1.88                              | 29                    | 669                   |

(b) (iii) The reaction of rubidium with water is exothermic. What is meant by the term *exothermic*? [1]

**SOLUTION**

(b) (iii) Exothermic reaction releases heat energy to the surroundings where products have lower energy than reactants and  $\Delta H$  is negative

**17**

[J15/P2/QA2/b]

Hydrogen reacts with halogens to form hydrogen halides.

(b) The reaction between hydrogen and chlorine is exothermic.

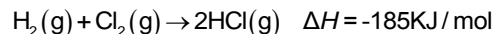

- (i) Explain, in terms of bond breaking and bond forming, why this reaction is exothermic. [2]  
(ii) When one mole of chlorine molecules reacts, 185 kJ of energy is released.  
Calculate the amount of energy released when 106.5 g of chlorine reacts. [2]

**SOLUTION**

- (b) (i) Bond breaking is endothermic and absorbs energy while bond formation is exothermic and releases energy. In this reaction, less energy is absorbed than the energy released hence the reaction is exothermic  
(ii) Moles in 106.5 g of chlorine =  $106.5/71 = 1.5 \text{ mol}$  (*Moles = mass/Mr*)  
Amount of energy release by 1.5 mol =  $1.5 \times 185 = 277.5 \text{ kJ}$

**18**

**[J16/P2/QB9/a,b]**

Carbon monoxide reacts with hydrogen in a reversible reaction.

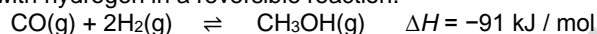

The reaction reaches an equilibrium if carried out in a closed container.

- (a) Explain, in terms of bond breaking and bond forming, why this reaction is exothermic. [2]  
(b) When one mole of methanol, CH<sub>3</sub>OH, is formed, 91 kJ of energy is released.  
Calculate the amount of energy released when 160g of methanol is formed.  
[M<sub>r</sub> of methanol = 32] [2]

**SOLUTION**

- (a) Breaking of bonds absorbs energy and is endothermic while making of bonds releases energy and is exothermic. In this reaction, more bonds are formed than broken and hence more energy is released than absorbed so the above the reaction is exothermic  
(b) Moles of methanol =  $160/32 = 5 \text{ mol}$   
When 1 mole releases 91kJ of energy, 5 mole will release  $(5 \times 91) = 455 \text{ kJ}$  of energy  
energy released = **455 kJ**

## UNIT-6

## CHEMICAL REACTIONS

### 6.1 Rate Of Reaction

#### 1 [J05/P2/QB7/c(ii)]

- (c) At room temperature ozone decomposes slowly to form oxygen, O<sub>2</sub>.  
The decomposition can be represented by the equation below. The reaction is exothermic. One mole of ozone will release 143 kJ when it is fully decomposed.

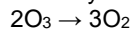

- (ii) Explain why the **rate** of this decomposition increases as the **temperature** increases.

#### SOLUTION

- (c) (ii) An increase in the temperature increases the kinetic energy of the molecules. The molecules move faster and cause more frequent collisions increasing the reaction rate.

#### 2 [N05/P2/QA5/a(i),b,c]

An experiment was carried out to measure the rate of reaction between excess powdered calcium carbonate and dilute acids.

- (a) In **Experiment 1**, 25 cm<sup>3</sup> of 1.5 mol/dm<sup>3</sup> hydrochloric acid was used.  
Complete the equation for the reaction by filling in the missing state symbols.  
(i)  $2\text{HCl}(\dots\dots\dots) + \text{CaCO}_3(\dots\dots\dots) \rightarrow \text{CaCl}_2(\text{aq}) + \text{H}_2\text{O}(\dots\dots\dots) + \text{CO}_2(\dots\dots\dots)$
- (b) A further experiment using hydrochloric acid, **Experiment 2**, was carried out.  
The results of **Experiments 1** and **2** are shown on the graph.

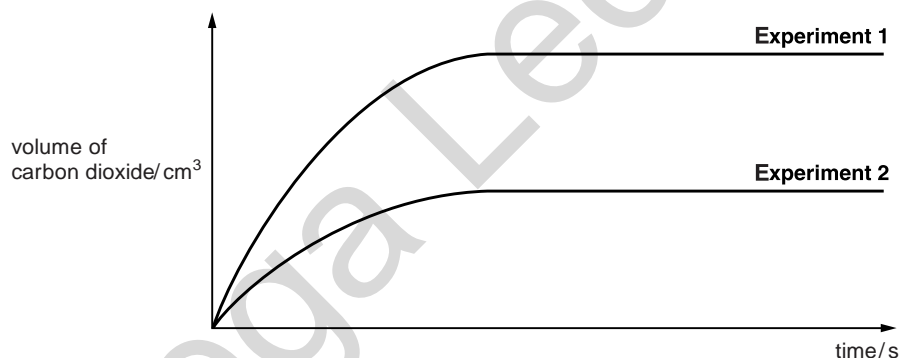

- (c) Suggest the **concentration** and **volume** of acid used for **Experiment 2**. [2]  
**Experiment 3** was carried out using 25 cm<sup>3</sup> of 1.5 mol/dm<sup>3</sup> sulphuric acid.  
The initial rate of reaction for **Experiment 3** was faster than for the other experiments but the reaction stopped suddenly after only a small amount of gas had been given off.
- (i) Name the salt formed in **Experiment 3**.  
(ii) Explain why the reaction stops suddenly.  
(iii) Explain why the initial rate of reaction was faster than for the other experiments. [4]

#### SOLUTION

- (a) (i)  $2\text{HCl}(\text{aq}) + \text{CaCO}_3(\text{s}) \rightarrow \text{CaCl}_2(\text{aq}) + \text{H}_2\text{O}(\text{l}) + \text{CO}_2(\text{g})$

- (b) Experiment 2: Concentration of HCl =  $0.75 \text{ mol/dm}^3$   
Volume =  $12.5 \text{ cm}^3$   
(The rate of reaction in experiment 2 is approximately half the rate of reaction in experiment 1. The volume of  $\text{CO}_2$  is half that produced in experiment 1. Since the HCl is the limiting reactant, the number of mol of HCl used in experiment 2 is half of that in experiment 1)
- (c) (i) Calcium sulphate  
(ii)  $\text{CaSO}_4$  is an insoluble salt. It forms a layer around the remaining calcium carbonate preventing further reaction with sulphuric acid  
(iii) Sulphuric acid is a dibasic acid containing twice the number of moles of hydrogen as compared to hydrochloric acid. Greater number of hydrogen ions increases the frequency of collision at the start of the chemical reaction.

3

[N06/P2/QA3]

A student investigated the reaction of calcium carbonate with hydrochloric acid.

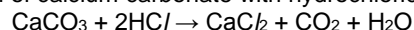

The student used large pieces of calcium carbonate and carried out the reaction at  $20^\circ\text{C}$ .

The concentration of hydrochloric acid was  $1.0 \text{ mol/dm}^3$ .

The results of the experiment were plotted as a graph which is shown below.

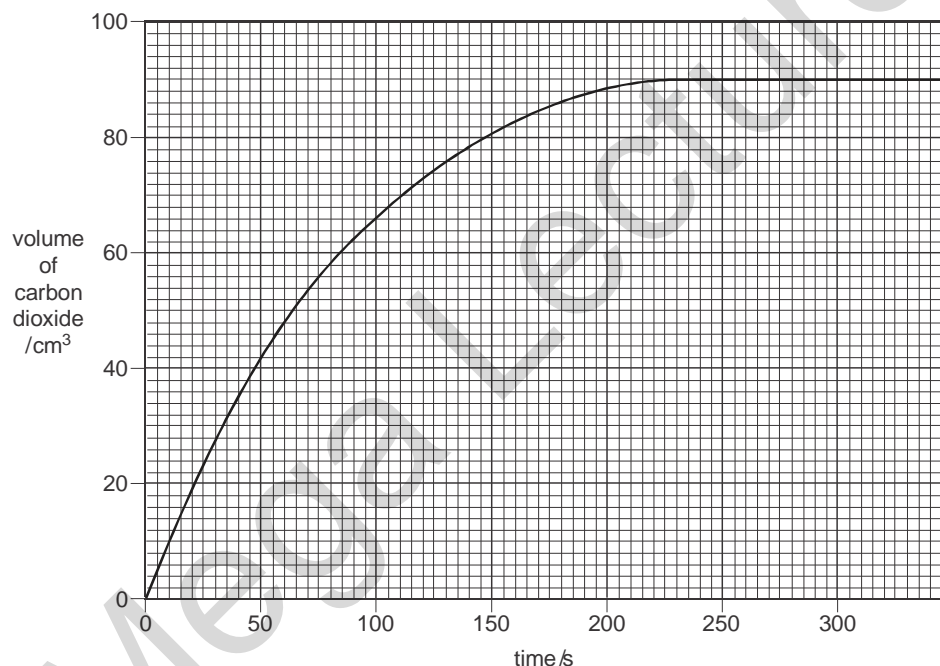

- (a) After how many seconds did the reaction stop? [1]
- (b) Calculate the number of moles of carbon dioxide released during the reaction. [1]  
[The volume of one mole of any gas at r.t.p. is  $24 \text{ dm}^3$ ]
- (c) The student repeated the experiment using the same mass of calcium carbonate and the same concentration of acid at  $20^\circ\text{C}$ . This time the student used small pieces of calcium carbonate. On the grid opposite, sketch the graph for the reaction of small pieces of calcium carbonate with hydrochloric acid. [2]



- (d) When the student repeated the experiment using hydrochloric acid of concentration  $2.0 \text{ mol/dm}^3$ , the speed of reaction increased. Use the kinetic particle theory to explain why the speed of this reaction increased. [2]

**SOLUTION**

- (a) 225 seconds  
(Volume of  $\text{CO}_2$  stays constant at  $90 \text{ cm}^3$  after 225 seconds)
- (b)  $1 \text{ mole} = 24000 \text{ cm}^3$   
 $x \text{ moles} = 90 \text{ cm}^3$   
 $90/24000 = x = 0.0038 \text{ moles}$   
( $24 \text{ dm}^3 = 24000 \text{ cm}^3$ )
- (c)

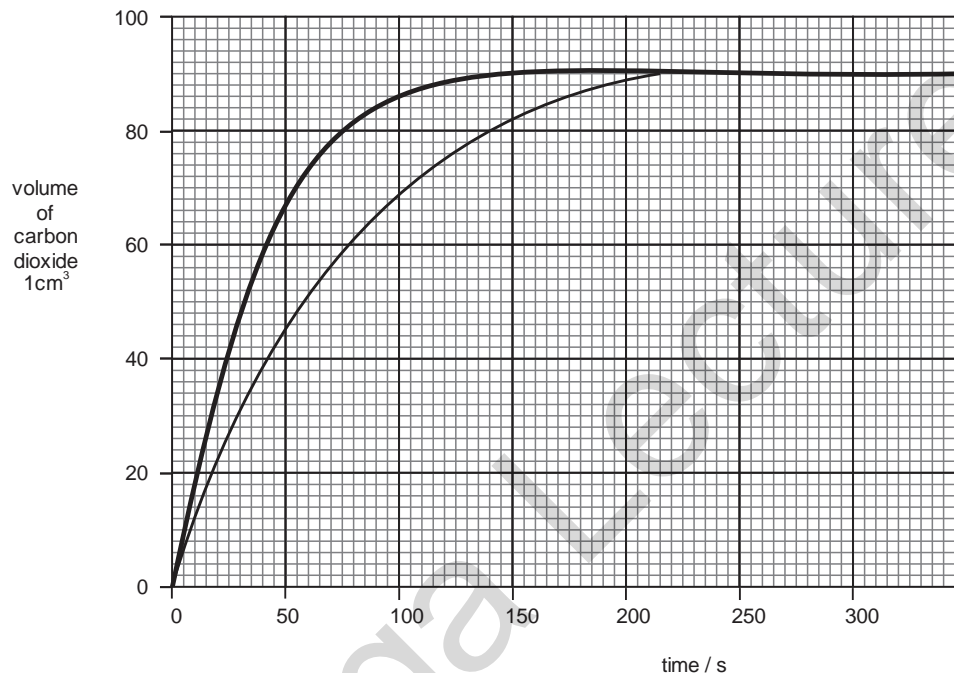

- (Small pieces of calcium carbonate have a greater surface area and hence this increases the rate of reaction)
- (d) There are more  $\text{H}^+$  ions in  $2 \text{ mol dm}^{-3}$  of HCl and hence frequency of collisions with calcium carbonate molecules increases, increasing the speed of reaction.

**4**

**[N06/P2/QB8/b(iii)]**

- (b) In the converter, sulphur dioxide and oxygen are passed over a series of catalyst beds at a temperature of about  $420 \text{ }^\circ\text{C}$ .

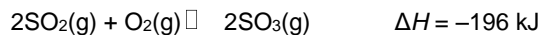

- (iii) In some sulphuric acid plants, the gases are cooled when they pass from one catalyst bed to the next. Use the equation to explain why the gases need to be cooled. [2]

**SOLUTION**

- (b) (iii) Since the reaction is exothermic, the heat given out will cause the reaction to shift backwards. Cooling the gases, however, will favour the forward reaction.

**5** [N07/P2/QA6/c]

- (c) The gases produced by the burning charcoal and sulphur cause the rocket to move upwards. Explain why the charcoal and sulphur in the rocket 'motor' are present as small grains rather than as large lumps. [2]

**SOLUTION**

- (c) Smaller grains have larger surface area resulting in more effective collisions and increased rate of reaction

**6** [N07/P2/QB10/e]

- (e) Calcium carbonate reacts with hydrochloric acid. Describe how you would investigate the rate of reaction of calcium carbonate with hydrochloric acid. Give a brief description of the apparatus you would use and the measurements you would make. [3]

**SOLUTION**

- (e) Weighed mass of  $\text{CaCO}_3$  is taken in a small tube which is inserted in the conical flask containing HCl. The tube is tilted and  $\text{CaCO}_3$  is made to react with dilute HCl. The volume of gas produced is measured with the help of a gas syringe at various time intervals. Total volume of gas and total time is used to calculate the rate of reaction

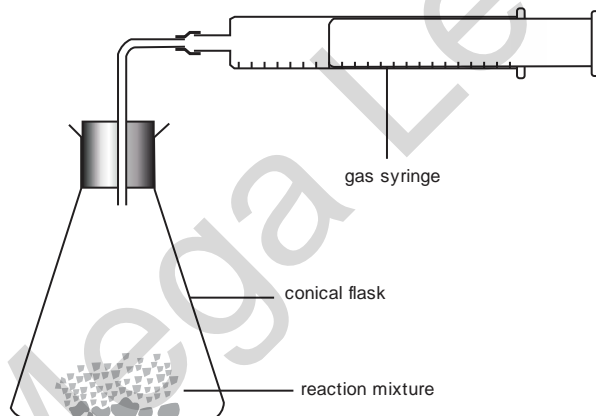

NOTE ; hang a test tube with thread inside a conical flask or copy similar diagram that would be more appropriate.

**7** [J08/P2/QB10/c(i)]

- (c) (i) Suggest why brass was used in a powdered rather than lump form. [1]

**SOLUTION**

- (c) (i) To increase the rate of reaction  
(In the powered form, the surface area of brass increases, thus increasing the rate of reaction)

**8 [N08/P2/QA2/a,b,c]**

Several small pieces of magnesium are placed on a block of solid carbon dioxide. The solid carbon dioxide is at a temperature of  $-60\text{ }^{\circ}\text{C}$ . The magnesium is ignited and another block of solid carbon dioxide is immediately placed on top.

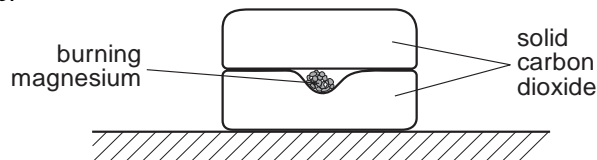

A vigorous reaction is observed.

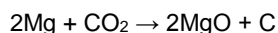

- (a) Suggest what could be seen as the reaction proceeds to completion. [2]  
 (b) Why is another block of solid carbon dioxide placed above the burning magnesium? [1]  
 (c) State **one** factor in the experiment which slows down the reaction. [1]

**SOLUTION**

- (a) Solid carbon dioxide vaporizes  
 White powder is formed  
 (The heat causes solid carbon dioxide to melt and white powder of MgO is formed. Other possible answers: black fumes and bright white light is seen)  
 (b) To stop Mg from reacting with oxygen in the air  
 (c) Low temperature of solid carbon dioxide

**9 [N09/P2/QA2/c,d]**

In the presence of yeast, aqueous glucose,  $\text{C}_6\text{H}_{12}\text{O}_6$ , is changed into carbon dioxide and ethanol.

- (c) Suggest how the speed of this reaction varies as the temperature changes from  $20$  to  $60\text{ }^{\circ}\text{C}$ . [2]  
 (d) Carbon dioxide is also formed when calcium carbonate reacts with hydrochloric acid.



The graph shows how the volume of carbon dioxide changes when calcium carbonate powder reacts with excess  $0.5\text{ mol/dm}^3$  hydrochloric acid.

On the same axes, sketch the curve you would expect when the experiment is repeated using the same amount of calcium carbonate and excess  $1.0\text{ mol/dm}^3$  hydrochloric acid. [2]

**SOLUTION**

- (c) Speed of the reaction increases with increase in temperature. At higher temperature, yeast is denatured; therefore reaction slows down and then stops eventually

(d)

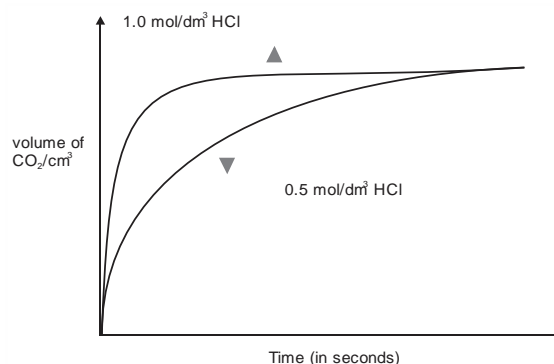

10

[N09/P2/QA4/d(i)]

Methylamine is made by reacting methanol with excess ammonia under pressure in the presence of a catalyst.

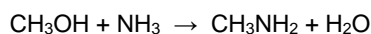

(d) (i) Define the term *catalyst*. [1]

**SOLUTION**

(d) (i) A substance which speeds up a reaction by providing an alternate route thus lowering the activation energy and remains chemically unchanged at the end of the reaction.

11

[N09/P2/QB9/d(i)]

In the oceans carbon dioxide reacts with carbonate ions in seawater to form hydrogen carbonate ions.



(d) (i) Microscopic plants remove carbon dioxide from the surface waters of the oceans. What effect does this have on the reaction above? Explain your answer. [2]

**SOLUTION**

(d) (i) As  $\text{CO}_2$  is removed from the surface, the equilibrium shifts towards left producing more  $\text{CO}_2$ , water and carbonate ions. As a result, concentration of bicarbonate ions decreases.

12

[J10/P2/QA3/a,b,c,d]

The diagram below shows apparatus that can be used to investigate the rate of reaction between zinc and hydrochloric acid.

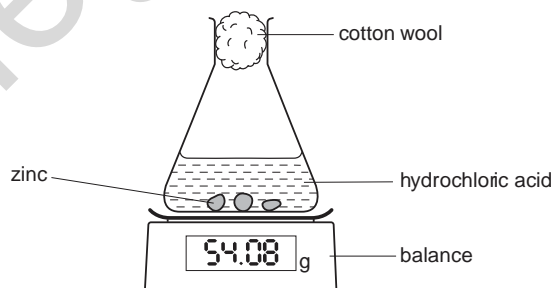

- (a) Write the equation, including state symbols, for the reaction between zinc and hydrochloric acid. [2]  
(b) The graph shows the change in mass that occurs during the reaction between zinc and hydrochloric acid.

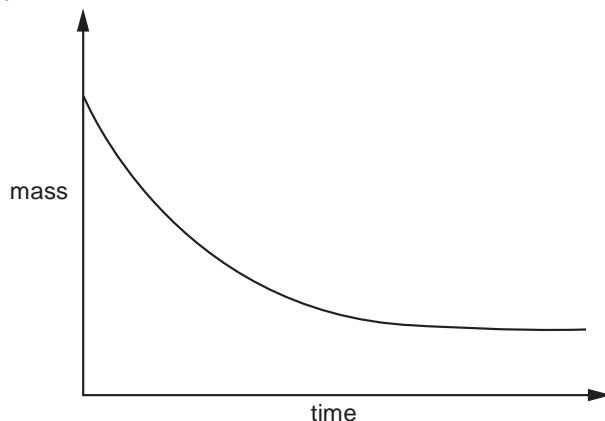

- (i) Explain why the mass decreases during the course of the reaction. [1]  
(ii) Exactly the same experiment was repeated but with a catalyst added. Sketch on the graph the results that would be obtained in the presence of the catalyst. [2]  
(c) Explain why zinc reacts more slowly with dilute hydrochloric acid than with concentrated hydrochloric acid. [2]  
(d) Explain why hydrochloric acid reacts much faster with zinc powder than with lumps of zinc. [2]

**SOLUTION**

- (a)  $\text{Zn}_{(s)} + 2\text{HCl}_{(aq)} \rightarrow \text{ZnCl}_{2(aq)} + \text{H}_{2(g)}$   
(b) (i) Hydrogen gas produced escapes during the reaction decreasing the mass.  
(ii)

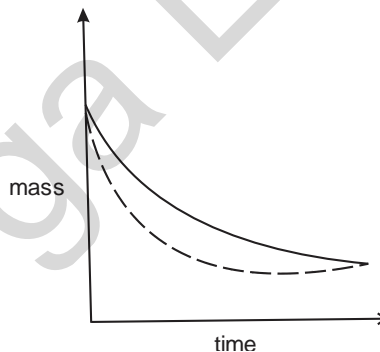

- (c) Particles in dilute HCl are less crowded than those in concentrated HCl and hence frequency of collisions is lower.  
(d) The surface area of Zn is much greater in powder form as compared to lump form. Larger surface area allows greater frequency of collisions and hence reaction proceeds faster. Rate of reaction is inversely proportional to size of the reacting particle.

13

[N10/P2/QA3]

A student measured the volume of hydrogen produced over time when small pieces of zinc reacted with excess sulfuric acid.

The results are shown in the graph below.

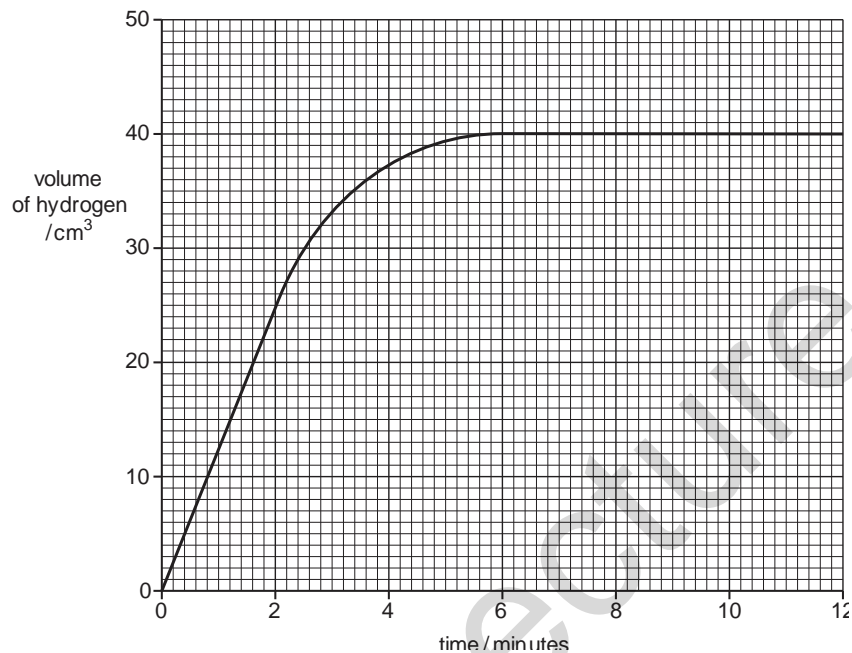

- (a) Use the information from the graph to calculate the average speed of reaction in the first two minutes. [1]
- (b) Explain why the reaction stopped after 6 minutes. [1]
- (c) Copper catalyses this reaction.
- (i) On the axes above, sketch a line to show the expected results for the catalyzed reaction. [1]
- (ii) Explain how a catalyst changes the speed of reaction. [1]
- (d) Explain, using ideas about colliding particles, what happens to the speed of this reaction when larger particles of zinc are used. [2]
- (e) Explain, using ideas about colliding particles, what happens to the speed of this reaction when the temperature of the reaction mixture is increased. [2]

**SOLUTION**

(a)  $\frac{y_2 - y_1}{x_2 - x_1} = \frac{25 - 0}{2 - 0} = 12.5 \text{ cm} / \text{min}$

Gradient = speed of reaction

(b) Since sulfuric acid is in excess, all the zinc must have reacted and hence reaction stopped

(c) (i)

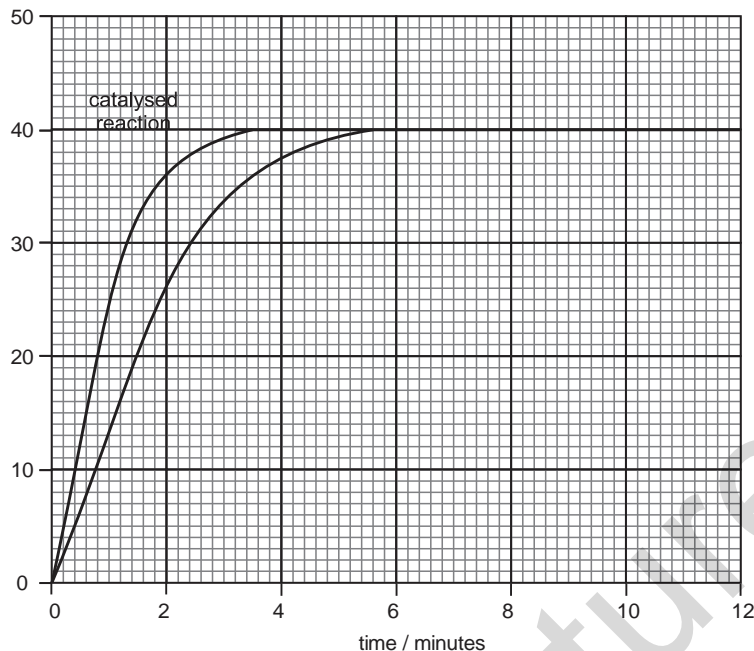

- (ii) A catalyst lowers the activation energy of a reaction.
- (d) The speed of reaction decreases when larger particles of zinc are used due to decrease in surface area of these particles. Less surface area means fewer particles are exposed to react per minute and hence the frequency of collisions decreases.  
Larger surface area increases frequency of collisions
- (e) Speed of the reaction increases with **an** increase in temperature of the reaction mixture. This is because, with an increase in temperature, the energy of reacting particles and the frequency of collisions **also** increase.  
Higher temperature increases frequency of collisions

14

[J11/P2/QB7/d]

Nitric oxide, NO, is an atmospheric pollutant formed inside car engines by the reaction between nitrogen and oxygen.

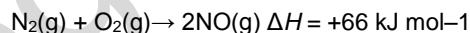

This reaction is endothermic.

- (d) Explain how the speed of reaction between nitrogen and oxygen changes when the pressure of the gaseous mixture is increased from 1 atmosphere to 10 atmospheres. [3]

**SOLUTION**

- (d) An increase in pressure means more number of particles are present in the same volumes. Thus they will collide more frequently, resulting in faster rate of chemical reactions.

15

[J11/P2/QB8/c(ii)]

- (c) In an experiment magnesium ribbon is added to 25.0 cm<sup>3</sup> of 1.00 mol/dm<sup>3</sup> hydrochloric acid, an excess.

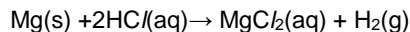

Every 30 seconds the total volume of hydrogen formed is measured at room temperature and pressure. The results are shown on the grid below.

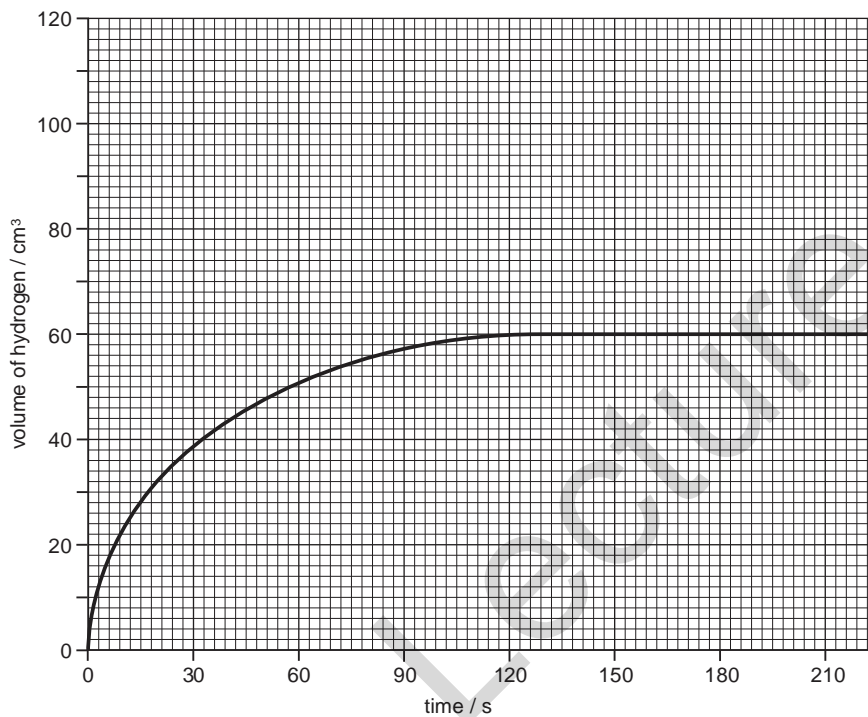

- (ii) The experiment was repeated using the same mass of magnesium ribbon but with 25.0 cm<sup>3</sup> of 1.00 mol/dm<sup>3</sup> propanoic acid, an excess. Draw on the grid a graph of the results for the reaction between magnesium ribbon and propanoic acid.

[2]



**SOLUTION**

(c) (ii)

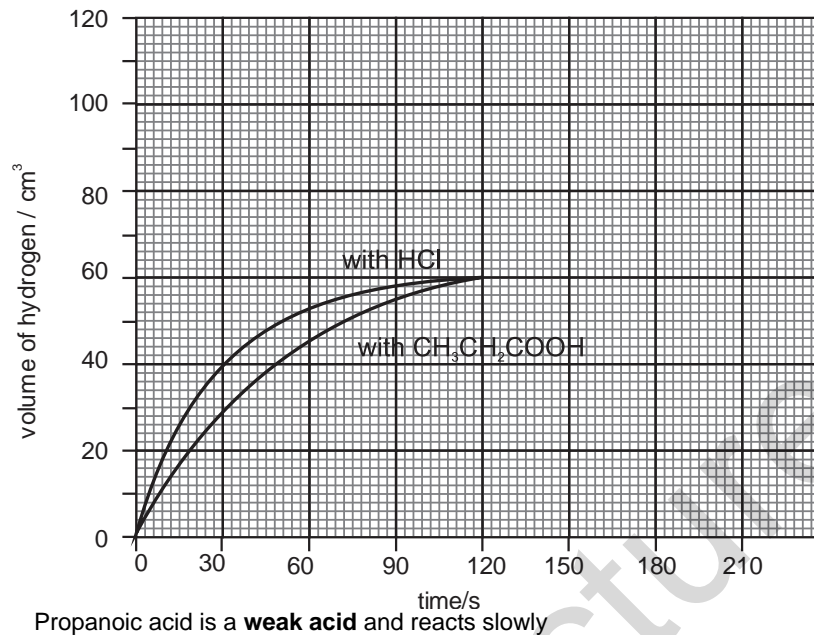

**16**

**[N11/P2/QB7/d(i)]**

(d) Magnesium reacts with dilute sulfuric acid.

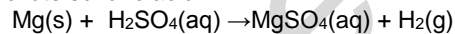

(i) Describe how you can follow the progress of this reaction.  
What measurements can you use to calculate the speed of the reaction? [3]

**SOLUTION**

(d) (i)

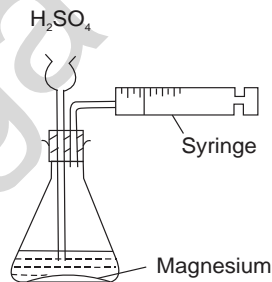

A piece of Magnesium metal is placed in the flat bottomed flask fitted with a dropping funnel and a gas syringe. Sulfuric acid is gradually added through dropping funnel and a stopwatch is started. Volume of the gas collected in the syringe is noted with time and the rate of reaction is calculated with the following formula; rate = change in volume/time

17

[J12/P2/QB6/d]

Hydrogen-oxygen fuel cells are used to generate electricity.  
The overall reaction in a hydrogen-oxygen fuel cell is shown below.

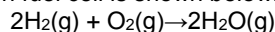

This reaction is exothermic.

(d) The electrode reactions in an oxygen-hydrogen fuel cell are shown below.

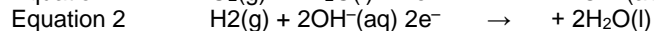
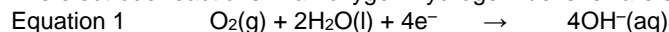

Explain why the reaction in a fuel cell involves both oxidation **and** reduction.

[2]

**SOLUTION**

(d) First equation involves reduction since electrons are gained/oxygen is reduced and second equation involves oxidation since electrons are lost/hydrogen is oxidized.  
(Oxygen's oxidation number decreases and hydrogen's oxidation number increases)

18

[J12/P2/QB9/a]

Methanol,  $\text{CH}_3\text{OH}$ , is manufactured from carbon dioxide and hydrogen.

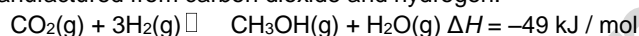

The reaction is carried out in the presence of a catalyst containing copper. The conditions used are 70 atmospheres pressure and a temperature of 250 °C.

(a) If the temperature of the reaction mixture is **increased** to 400 °C, explain, in terms of collisions between reacting particles, what happens to the speed of the forward reaction.

[2]

**SOLUTION**

(a) Speed of the reaction would increase because more particles will collide hence more effective collisions take place

19

[N12/P2/QA3/a,b(i)]

The rate of reaction of iron with aqueous bromine is determined using the apparatus shown below.

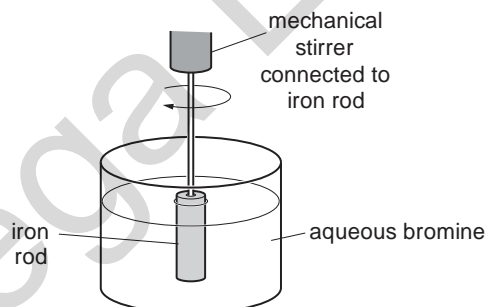

The iron is removed at regular intervals. It is washed, dried and then weighed. The iron is then replaced in the solution.

The experiment is repeated twice, each time with a different concentration of aqueous bromine.

The results are shown in the table below.

| concentration of aqueous bromine<br>mol / dm <sup>3</sup> | speed of reaction<br>mg iron reacted / min |
|---|--|
| 0.050   | 9.2  |
| 0.10  | 18.1                                       |
| 0.15  | 27.2                                       |

- (a) (i) Describe how and explain why the speed of this reaction changes with the concentration of bromine. [2]  
 (ii) Describe and explain the effect of temperature on the speed of this reaction. [2]  
 (iii) Suggest another method of measuring the speed of this reaction. [1]  
 (b) (i) Construct two half-equations for this reaction to show electron loss and gain. [2]

**SOLUTION**

- (a) (i) The speed of the reaction increases with increase in bromine concentration because there are more bromine molecules present in a given volume causing frequency of collisions to increase. Hence, more effective collisions take place  
 (ii) Increasing temperature increases the rate of reaction because more particles have an energy greater than the activation energy and, thus, more effective collisions take place  
 (iii) Remove the iron at regular intervals of one minute and measure the electrical conductivity of the solution. Replace the iron rod and repeat the experiment with different concentrations of bromine  
 (Other possible answer: Measure the color of the solution over time using a colorimeter)  
 (b) (i)  $\text{Fe} \rightarrow \text{Fe}^{2+} + 2\text{e}^{-}$   
 $\text{Br}_2 + 2\text{e}^{-} \rightarrow 2\text{Br}^{-}$

**20**

**[J13/P2/QA5/e]**

Analysis of compound **X** shows it has the following composition.

| element  | percentage by mass |
|----------|--------------------|
| hydrogen | 3.40               |
| nitrogen | 12.0               |
| oxygen   | 41.0               |
| vanadium | 43.6               |

- (e) When solid **X** is heated only V<sub>2</sub>O<sub>5</sub>, water and gas **Z** are formed. Name gas **Z**. [1]

**SOLUTION**

- (e) Ammonia

**21**

**[J13/P2/QB7/a,c]**

- (a) Describe, with the aid of a labelled diagram, the apparatus needed to collect this data. [2]  
 (c) The student repeats the experiment. This time she uses a 0.500 g antacid tablet and 50.0 cm<sup>3</sup> of **2.00 mol / dm<sup>3</sup> HC** instead of 50.0 cm<sup>3</sup> of 1.00 mol / dm<sup>3</sup> HC/. Describe and explain what will happen to the rate of reaction. [2]

**SOLUTION**

(a)

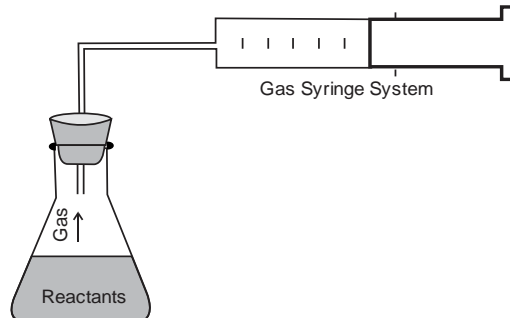

- The gas is collected in the measuring cylinder and the volume is noted on specific time intervals to obtain the graph
- (c) The reaction would be faster because HCl particles are now more crowded resulting in more effective collisions.

**22** **[J13/P2/QB9/a(i)]**

Methane reacts with water to produce hydrogen and carbon monoxide.  

$$\text{CH}_4(\text{g}) + \text{H}_2\text{O}(\text{g}) \rightleftharpoons 3\text{H}_2(\text{g}) + \text{CO}(\text{g}) \quad \Delta H = +210 \text{ kJ / mol}$$

This reaction is endothermic.

The reaction is normally carried out at a pressure of 30 atmospheres and a temperature of 850 °C.

- (a) The reaction is carried out at 30 atmospheres pressure and at **600 °C** rather than 850 °C.  
 Predict and explain the effect of lowering the temperature on  
 (i) the rate of reaction, [2]

**SOLUTION**

- (a) (i) Reaction is slower because particles move slower and there are less number of effective collisions

**23** **[N13/P2/QA5/b]**

- (b) (i) On the axes below draw a sketch graph to show how the volume of gas produced during the reaction varies with time and label this line 'A'.  
 Label the axes with the appropriate units. [2]

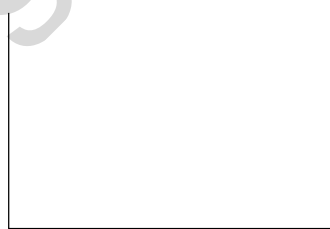

- (ii) The student then carries out the experiment at a **lower** temperature. All the other conditions remain the same. [2]

On the axes above draw another line to show how the volume of gas produced varies with time and label this line 'B'. [1]

**SOLUTION**

(b) (i)

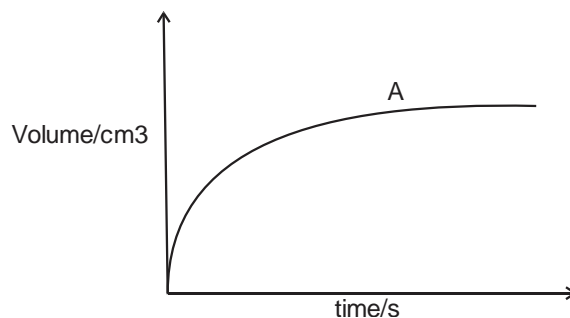

(ii)

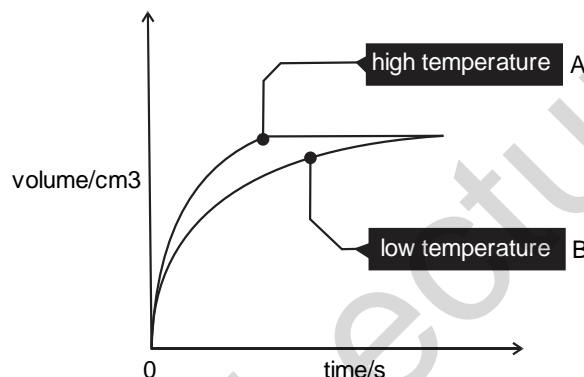

**24**

**[N13/P2/QB8/b(ii)]**

(b) (ii) Describe and explain the differences in the concentrations of reactant and products at 25 °C and 450 °C. [2]

**SOLUTION**

(b) (ii) At 25 °C, there is higher concentration of reactant and lower concentration of products because a decrease in temperature shifts an endothermic reaction to the left hand side. However, at 450 °C, there is lower concentration of reactant and higher concentration of products because an increase in temperature shifts an endothermic reaction to the right hand side.

**25**

**[J14/P2/QB9/b]**

(b) Describe and explain what happens to the rate of the forward reaction when the temperature is increased. The pressure remains constant. [2]

**SOLUTION**

(b) The rate of reaction increases as particles have higher kinetic energy and are moving faster. This results in more fruitful collisions.

26

[J14/P2/QB10/d(i)]

- (d) (i) Bromine reacts with aqueous magnesium astatide. Construct the ionic equation for this reaction. [1]

**SOLUTION**

- (d) (i)  $\text{Br}_2 + 2\text{At}^- \rightarrow 2\text{Br}^- + \text{At}_2$ .

27

[N14/P2/QA4/b(i)]

- (b) The graph below shows how the pH changes when aqueous sulfuric acid is added slowly to 45.0 cm<sup>3</sup> of 0.150 mol / dm<sup>3</sup> sodium hydroxide until the acid is in excess.

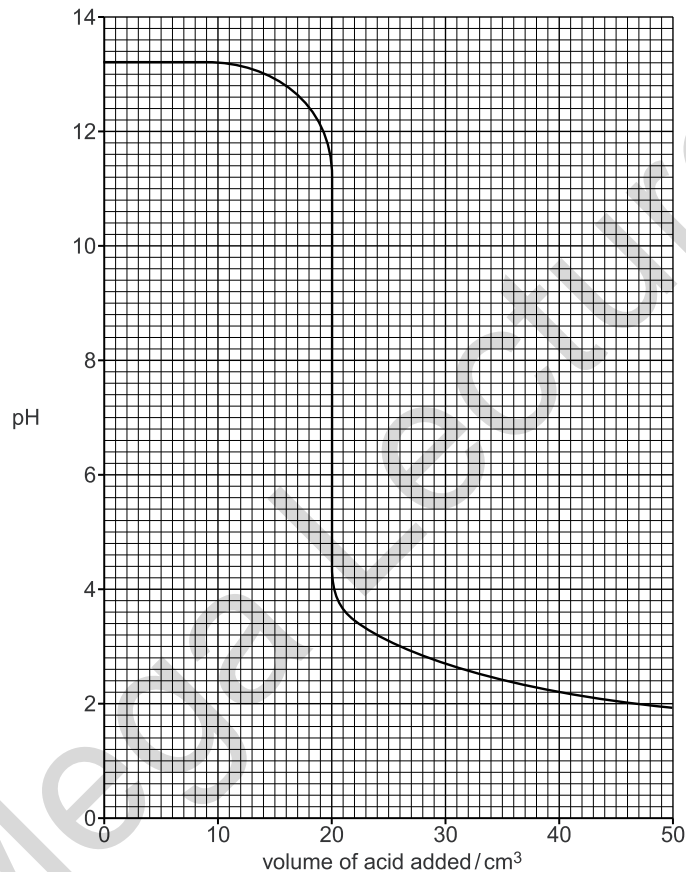

- (i) What volume of acid has been added when the pH is 7? [1]

**SOLUTION**

- (b) (i) 20 cm<sup>3</sup>  
(Read from the graph)

28

[N14/P2/QB3/a(iii)]

The ester, ethyl ethanoate, reacts with hydroxide ions to form ethanoate ions and ethanol.

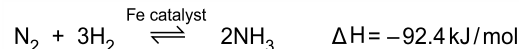

- (a) The graph shows how the concentration of ethanoate ions,  $\text{CH}_3\text{COO}^-$ , changes as the reaction proceeds.

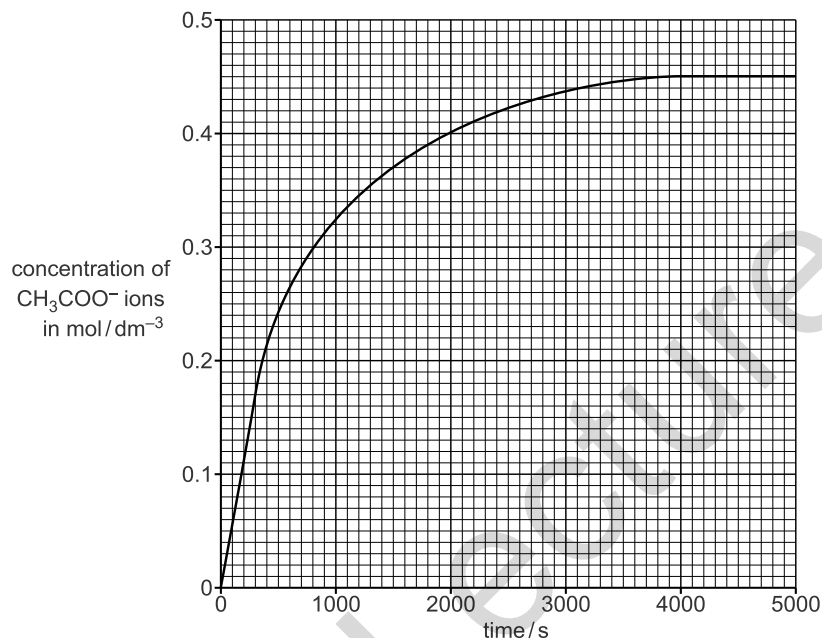

- (iii) Describe and explain, using the kinetic particle theory, the change in the rate of reaction with time. [3]

**SOLUTION**

- (a) (iii) Rate of reaction decreases with time as the reactants are used up and the concentration of  $\text{H}^+$  ions decreases. This results in reduced frequency of collisions between ethyl ethanoate molecules and  $\text{OH}^-$  ions.

29

[N15/P2/QB10]

At 200 °C and 200 atmospheres pressure, phosphorus(V) chloride forms an equilibrium mixture with phosphorus(III) chloride and chlorine.

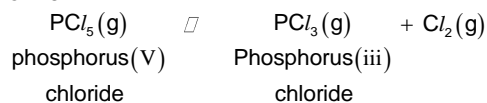

- (a) Predict and explain the effect of decreasing the pressure on the position of this equilibrium. The temperature remains constant. [2]
- (b) Predict and explain the effect of increasing the concentration of chlorine on the position of this equilibrium. [2]

- (c) The table shows the percentage of phosphorus (III) chloride in the equilibrium mixture at different temperatures. The pressure is the same in each case.

| temperature / °C | % $\text{PCl}_3$ in the mixture |
|------------------|---------------------------------|
| 200              | 48                              |
| 300              | 95                              |
| 400              | 99                              |

- (i) Describe how the composition of this equilibrium mixture changes with temperature. [1]  
 (ii) Explain what this tells you about the energy change in this reaction. [1]  
 (d) How is the position of equilibrium affected by the presence of a catalyst? [1]  
 (e) The rate of this reaction increases with increase in temperature. Explain why. [2]  
 (f) Phosphorus(V) chloride reacts with water. Phosphoric acid,  $\text{H}_3\text{PO}_4$ , and hydrogen chloride are formed. Construct the equation for this reaction. [1]

**SOLUTION**

- (a) Decreasing the pressure favors the forward reaction because decrease in pressure always favors the side of reaction with greater number of moles  
 (b) The backward reaction will be favored to produce  $\text{PCl}_5$  so that concentration of  $\text{Cl}_2$  is returned to normal  
 (c) (i) Increasing the temperature increases the %age of  $\text{PCl}_3$  in equilibrium mixture  
 (ii) This tells us that the forward reaction is endothermic because increasing the temp always favours endothermic reactions  
 (d) catalyst does not affect the position of equilibrium  
 (e) As temperature increases, molecules gain kinetic energy and move faster. Thus, more molecules have energy greater than activation energy resulting in more fruitful collisions  
 (f)  $\text{PCl}_5 + 4\text{H}_2\text{O} \rightarrow \text{H}_3\text{PO}_4 + 5\text{HCl}$ .

**30**

[J16/P2/QB10/b,c]

Manganese(IV) oxide,  $\text{MnO}_2$ , can be used in the preparation of both chlorine and oxygen.

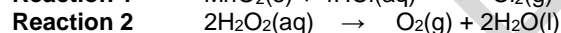
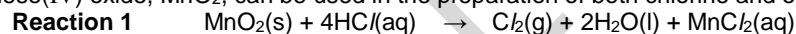

In **reaction 2** manganese(IV) oxide acts as a catalyst.

- (b) **Reaction 1** is investigated using different masses of  $\text{MnO}_2$ . The results are shown in the table.

| volume of HCl / $\text{cm}^3$ | concentration of HCl (aq) in $\text{mol} / \text{dm}^3$ | mass of $\text{MnO}_2$ used / g | volume of $\text{Cl}_2$ formed at room temperature and pressure / $\text{dm}^3$ |
|-------------------------------|---|---------------------------------|---|
| 100                           | 1.0   | 1.74                            | 0.48  |
| 100                           | 1.0   | 0.87                            | 0.24  |

Explain the difference in the volume of chlorine formed. [2]

- (c) **Reaction 2** is investigated using different masses of  $\text{MnO}_2$ . The results are shown in the table.

| volume of $\text{H}_2\text{O}_2(\text{aq})$ / $\text{cm}^3$ | concentration of $\text{H}_2\text{O}_2$ in $\text{mol} / \text{dm}^3$ | mass of $\text{MnO}_2$ used / g | volume of $\text{O}_2$ formed at room temperature and pressure / $\text{dm}^3$ |
|---|---|---------------------------------|--|
| 100   | 1.0   | 1.74                            | 1.20   |
| 100   | 1.0   | 0.87                            |  |



Predict the volume of oxygen, measured at room temperature and pressure, when 0.87g of  $\text{MnO}_2$  is used. Write your answer in the table. [1]

**SOLUTION**

- (b) Manganese (IV) oxide acts as a limiting reagent in reaction 1 while HCl is in excess. So reducing the amount of the limiting reagent to half also halved the volume of  $\text{Cl}_2$   
 (c) *(The mass of catalyst used has no effect on the product formed)*

**6.2 Redox**

**31 [J05/P2/QB8/b]**

- (b) Explain why the reaction between copper(I) chloride and chlorine involves both oxidation and reduction. [3]

**SOLUTION**

- (b) Oxidation is loss of electrons or an increase in oxidation number. Copper (I) is oxidized because it loses an electron and its oxidation number from +1 to +2.  
 Reduction is gain of electrons or a decrease in oxidation number. Chlorine is reduced because it gains an electron and its oxidation number decreases from 0 to -2.

**32 [N05/P2/QA6/a(i,ii)]**

The table below shows some information about two copper ores, tenorite and cuprite. Both contain copper oxide.

| ore      | formula of copper oxide in ore | oxidation number of copper | percentage of copper by mass |
|----------|--------------------------------|----------------------------|------------------------------|
| tenorite |                                | +2                         | 80.0%                        |
| cuprite  | $\text{Cu}_2\text{O}$          |                            |                              |

- (a) (i) What is the formula of the copper compound in tenorite?  
 (ii) What is the oxidation number of copper in cuprite,  $\text{Cu}_2\text{O}$ ?

**SOLUTION**

- (a) (i)  $\text{CuO}$   
 (ii) +1

**33 [N05/P2/QB9/b]**

- (b) Chlorine reacts with water to make a solution that can be used as a bleach. The equation is shown below.  
 $\text{Cl}_2 + \text{H}_2\text{O} \rightarrow \text{HCl} + \text{ClOH}$   
 Use oxidation numbers to show that chlorine is both oxidised and reduced in this reaction. [3]

**SOLUTION**

- (b)  $\text{Cl}_2$  is oxidized to  $\text{ClOH}$  and reduced to  $\text{HCl}$  simultaneously. In the oxidation process, the oxidation number of Cl increases from 0 in  $\text{Cl}_2$  to +1 in  $\text{ClOH}$ .  
 In the reduction process, the oxidation number of Cl decreases from 0 in  $\text{Cl}_2$  to -1 in  $\text{HCl}$   
 Air is liquefied to form a liquid and then fractionally distilled until oxygen boils off and is collected

34

[J06/P2/QA6/c]

- (c) When lithium reacts with water, lithium ions,  $\text{Li}^+$ , are formed.

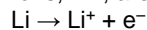

Explain why the formation of a lithium ion from a lithium atom is an example of oxidation. [1]

**SOLUTION**

- (c) Oxidation is the loss of electrons and in this reaction lithium atom loses an electron  
(Oxidation number of lithium increases)

35

[N06/P2/QB7/a,b]

A simplified diagram of the nitrogen cycle is shown below.

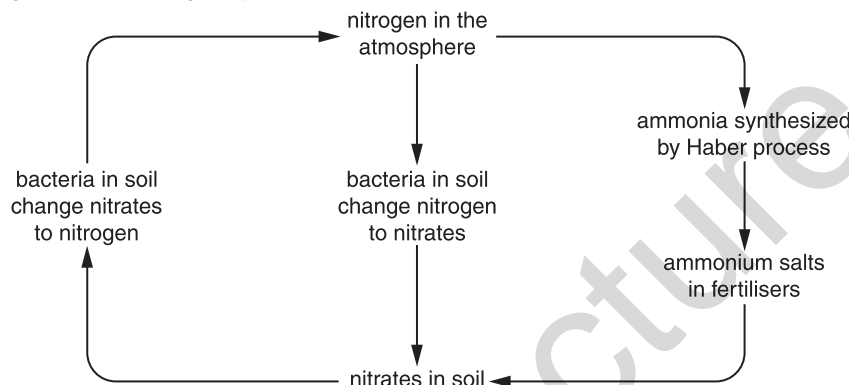

- (a) Although certain bacteria in the soil convert nitrogen gas into nitrates, other bacteria convert nitrogen into ammonium salts. The ionic equation for this second reaction is  

$$\text{N}_2 + 8\text{H}^+ + 6\text{e}^- \rightarrow 2\text{NH}_4^+$$
 Explain why this is a reduction reaction. [1]
- (b) In the presence of hydrogen ions, a different type of bacterium converts nitrate ions into nitrogen gas and water.  
 Give the ionic equation for this reaction. [1]

**SOLUTION**

- (a) Nitrogen has gained electrons and oxidation number of nitrogen has decreased  
(Reduction is gain of electrons and oxidation number of N changes from 0 to -3)
- (b)  $2\text{NO}_3^- + 12\text{H}^+ + 10\text{e}^- \rightarrow \text{N}_2 + 6\text{H}_2\text{O}$ .

36

[J07/P2/QA2/c]

- (c) Aqueous iron(II) ions can be oxidised by reaction with acidified potassium manganate (VII),  $\text{KMnO}_4$ . The colour change during the reaction shows that iron (II) ions act as a reducing agent.
- (i) Describe the colour change during the reaction. [1]
- (ii) In terms of oxidation numbers, explain the meaning of the term *reducing agent*. [1]

**SOLUTION**

- (c) (i) Purple to colorless  
 [( $\text{KMnO}_4$ ) is reduced]

- (ii) Reducing agent is a substance whose oxidation number increases.  
(Reducing agent is a substance which helps other substances to reduce and gets oxidized itself)

**37** [N07/P2/QA6/e(i,ii)]

- (e) (i) An aqueous solution of potassium chlorate (V) is a good oxidising agent.  
Describe a chemical test for an oxidising agent and state the result. [2]
- (ii) When potassium chlorate (V) reacts as an oxidising agent, the chlorate (V) ions are reduced to chloride ions.  
$$\text{ClO}_3^- + 6\text{H}^+ + 6\text{e}^- \rightarrow \text{Cl}^- + 3\text{H}_2\text{O}$$
  
How does this equation show that the chlorate (V) ion gets reduced? [1]

**SOLUTION**

- (e) (i) **Test:** Add aqueous potassium iodide to the oxidising agent  
**Result:** Solution turns from colorless to brown  
(KI solution is colorless which oxidises to iodine giving brown color)
- (ii) Oxidation number of chlorine atom in chlorate (V) ions decreases from +5 to -1. Also, gain of electrons takes place while reduction

**38** [J08/P2/QA1/d]

Choose from the following gases to answer the questions below.

**ammonia**      **argon**      **carbon monoxide**      **chlorine**      **hydrogen**  
**nitrogen**      **nitrogen dioxide**      **oxygen**

Each gas can be used once, more than once or not at all.  
Name a gas which

- (d) is a reducing agent in a Blast Furnace, [1]

**SOLUTION**

- (d) Carbon monoxide  
(CO can be oxidised to CO<sub>2</sub>, therefore acts as a reducing agent)

**39** [J08/P2/QA2/d]

- (d) Aqueous iron(II) ions can also be oxidised by reaction with acidified potassium dichromate(VI), K<sub>2</sub>Cr<sub>2</sub>O<sub>7</sub>. At the same time aqueous dichromate(VI) ions are reduced.  
(i) Describe the colour change of the chromium-containing species during the reaction. [1]  
(ii) Describe the colour change of the iron-containing species during the reaction. [1]

**SOLUTION**

- (d) (i) Orange to green  
(K<sub>2</sub>Cr<sub>2</sub>O<sub>7</sub> (orange) is reduced to Cr<sup>3+</sup> (green))  
(ii) Green to yellow  
(Fe<sup>2+</sup> (green) is oxidised to Fe<sup>3+</sup> (yellow))

**40** [J08/P2/QB7/a]

This question is about the chemistry of chlorine and some of its compounds.

- (a) Describe, with the aid of an ionic equation, the reaction of chlorine with aqueous potassium bromide. Explain why this reaction involves the reduction of chlorine. [3]

**SOLUTION**

- (a) When chlorine gas is passed through colorless potassium bromide, bromine is formed, turning the solution reddish brown  
 $\text{Cl}_2 + 2\text{Br}^- \rightarrow 2\text{Cl}^- + \text{Br}_2$ .  
As the oxidation number of Cl decreases from 0 to -1 by gaining an electron, it is reduced.  
(Reduction is the gain of electrons)

**41**

**[N08/P2/QA4/a]**

The head of a safety match contains potassium chlorate and antimony sulphide. The side of the match box contains red phosphorus.

When a match is struck on the side of the box, the friction produces enough heat to light the match.

- (a) The equation for this reaction is shown.

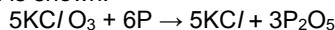

potassium chlorate phosphorus(V) oxide

Which is the oxidant and which is the reductant in this reaction?

Explain your answer.

oxidant

reductant

explanation

[2]

**SOLUTION**

- (a) **Oxidant:** Potassium chlorate  
**Reductant:** Phosphorus  
**Explanation:** Potassium chlorate loses oxygen whereas phosphorus gains oxygen

**42**

**[N08/P2/QB8/b(i)]**

- (b) (i) When **X** is warmed with acidified potassium manganate(VII), the solution changes from pink to colourless. [1]

**SOLUTION**

- (b) (i) Potassium permanganate is an oxidising agent. As it changes the color, this confirms its oxidising behavior. Therefore X is a reducing agent  
(Potassium permanganate changes color from pink to colorless when it is reduced)

**43**

**[N08/P2/QB10/c]**

- (c) Zinc can reduce iodine to iodide ions.  
Write an ionic equation for this reaction. [2]

**SOLUTION**

- (c)  $\text{Zn} + \text{I}_2 \rightarrow \text{Zn}^{2+} + 2\text{I}^-$ .

**44** [J09/P2/QA1/d,e]

- (d) can be used in the test for sulfur dioxide, [1]  
(e) reacts with aqueous potassium iodide to give a brown colour. [1]

**SOLUTION**

- (d) Potassium dichromate (VI)  
(It turns from orange to green in  $\text{SO}_2$ )  
(e) Chlorine  
(Other possible answers: Potassium dichromate (VI) / Manganese (IV) oxide / concentrated sulfuric acid)

**45** [J09/P2/QB11/a]

Aluminium and iron are both metals.  
Iron rusts in the presence of oxygen and water. Rusting involves a series of reactions.  
Initially iron atoms lose electrons to form iron(II) ions.

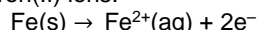

At the same time oxygen,  $\text{O}_2$ , and water molecules react to form hydroxide ions.

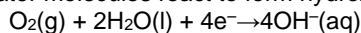

Aqueous iron(II) ions then react with aqueous hydroxide ions to form solid iron(II)hydroxide.

Finally the iron(II) hydroxide is oxidised to give hydrated iron(III) oxide (rust).

- (a) (i) Explain why the formation of iron(II) ions from iron atoms is an example of oxidation. [1]  
(ii) Write the ionic equation, including state symbols, for the reaction between iron(II)ions and hydroxide ions. [2]

**SOLUTION**

- (a) (i) Electrons are lost and the oxidation number of iron increases from 0 to +2  
(ii)  $\text{Fe}^{2+}(\text{aq}) + 2\text{OH}^{-}(\text{aq}) \rightarrow \text{Fe}(\text{OH})_2(\text{s})$ .

**46** [N09/P2/QA5/a]

Bromine is extracted by reacting the potassium bromide in seawater with chlorine.

- (a) Write an equation for this reaction. [1]

**SOLUTION**

- (a)  $2\text{KBr} + \text{Cl}_2 \rightarrow 2\text{KCl} + \text{Br}_2$   
(More reactive chlorine displaces less reactive bromine from its salt)

**47** [J10/P2/QA1/e]

- (e) is orange in colour, [1]

**SOLUTION**

- (e)  $\text{K}_2\text{Cr}_2\text{O}_7$   
 $\text{K}_2\text{Cr}_2\text{O}_7$  is an orange solution.

**48** [J10/P2/QB9/a,d(ii)]

Hydrogen and iodine react together to form hydrogen iodide in a reversible redox reaction.  
The forward reaction is endothermic.

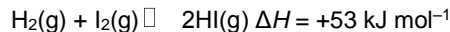

Hydrogen and hydrogen iodide are colourless gases whereas iodine gas is purple.

- (a) What is meant by the term *redox reaction*? [1]
- (d) Hydrogen iodide is dissolved in water to make solution **X**.  
(ii) A small volume of acidified potassium manganate(VII) is added to **X**. The solution changes colour to orange-brown.  
From this description what can you deduce about the chemical properties of **X**? [1]

**SOLUTION**

- (a) Redox reaction is a reaction in which oxidation and reduction takes place simultaneously. In redox reactions, one reactant gains electrons while other loses electrons.
- (d) (ii) X can be oxidised  
X is a reducing agent and helps reduce acidified potassium manganate (VII)

**49**

**[N10/P2/QA5/b(i)]**

Carbon and graphite are two forms of carbon.

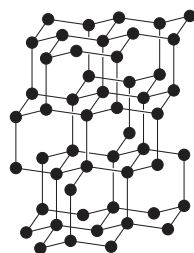

diamond

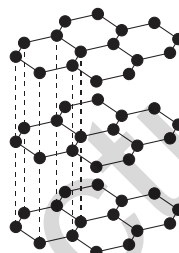

graphite

- (b) Tin is extracted by heating tin(IV) oxide,  $\text{SnO}_2$ , with carbon in a furnace.  
$$\text{SnO}_2 + 2\text{C} \rightarrow \text{Sn} + 2\text{CO}$$
  
(i) How does this equation show that tin(IV) oxide gets reduced? [1]

**SOLUTION**

- (b) (i) Oxygen is removed from tin (IV) oxide and its oxidation number decreases.  
Oxidation number of Sn is decreased from +4 in  $\text{SnO}_2$  to zero in Sn

**50**

**[N11/P2/QB9/c]**

- (c) Barium oxide reacts with aluminium.  
$$3\text{BaO} + 2\text{Al} \rightarrow 3\text{Ba} + \text{Al}_2\text{O}_3$$
  
Explain how this equation shows that aluminium is a reducing agent. [1]

**SOLUTION**

- (c) Aluminium removes oxygen from barium oxide and helps it to reduce. Also, aluminium itself gets oxidised.  
**Reducing agent gets oxidised it self**

**51**

**[N12/P2/QB6/a(i),c]**

Seawater contains chloride, bromide and iodide ions.  
Bromine can be manufactured by bubbling chlorine through seawater.

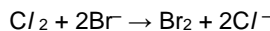

- (a) (i) Explain why the reaction of chlorine with bromide ions involves both oxidation and reduction. [2]
- (c) Chlorine reacts with cold dilute sodium hydroxide to form sodium chlorate (I), NaClO, sodium chloride and water. Construct an equation for this reaction. [1]

**SOLUTION**

- (a) (i) Chlorine gains electrons and is reduced  
Bromide ions loses electrons and is oxidised
- (c)  $\text{Cl}_2 + 2\text{NaOH} \rightarrow \text{NaClO} + \text{NaCl} + \text{H}_2\text{O}$

**52 [J13/P2/QA5/d]**

- (d) An acidified aqueous solution of X reacts with aqueous potassium iodide to form iodine. State and explain what you can deduce about the chemical nature of X. [2]

**SOLUTION**

- (d) X is an oxidizing agent because it causes the oxidation number of iodine to increase (Oxidation number increases from -1 in KI to 0 in I<sub>2</sub>)

**53 [J13/P2/QA6/a]**

A 0.250 g sample of iron filings is added to 25.0 cm<sup>3</sup> of 0.100 mol / dm<sup>3</sup> aqueous copper(II) sulfate.

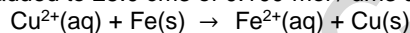

- (a) Explain, using electron transfer, why iron is oxidised in this reaction. [1]
- (c) What would you observe in this reaction? [2]

**SOLUTION**

- (a) Iron loses electrons and so it is oxidised
- (c) Blue solution of CuSO<sub>4</sub> turns pale green (FeSO<sub>4</sub>) and pink solid (Cu) is formed.

**54 [J14/P2/QA5/d]**

(d) When magnesium powder is added to aqueous iron(II) sulfate, the following reaction occurs.

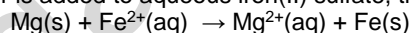

- (i) Explain, using electron transfer, why iron(II) ions are reduced in this reaction. [1]
- (ii) What would you observe in this reaction? [1]

**SOLUTION**

- (d) (i) Iron(II) ions gain electrons and hence are reduced (Reduction is gain of electrons)
- (ii) Green solution fades and magnesium becomes coated with a dark solid

**55 [J16/P2/QB10/a]**

Manganese(IV) oxide, MnO<sub>2</sub>, can be used in the preparation of both chlorine and oxygen.

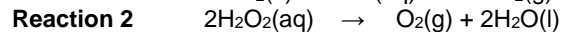
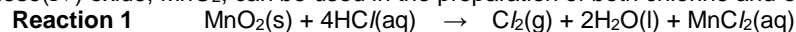

- In **reaction 2** manganese(IV) oxide acts as a catalyst.  
**(a)** **Reaction 1** converts chloride ions into chlorine molecules.  
 Explain why this is an example of oxidation. [1]

**SOLUTION**

- (a)** Chloride ion loses electrons and oxidation state of chlorine increases from -1 to 0.

**6.3 Equilibrium & Dynamic Equilibrium**

**56** [N08/P2/QB7/c]

Ammonia is made by the Haber process using an iron catalyst.



- (c)** Explain how the position of equilibrium in the Haber process is altered by  
**(i)** an increase in pressure, [2]  
**(ii)** an increase in temperature. [2]

**SOLUTION**

- (c)** **(i)** As the pressure increases, equilibrium will shift from larger volume to lower volume, therefore position of equilibrium will move to right side of the equation.  
**(ii)** As the reaction is exothermic, increase in temperature will shift the position of equilibrium towards left hand side of the equation to lower the temperature.

**57** [J10/P2/QB9/b]

Hydrogen and iodine react together to form hydrogen iodide in a reversible redox reaction.  
 The forward reaction is endothermic.

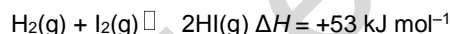

Hydrogen and hydrogen iodide are colourless gases whereas iodine gas is purple.

- (b)** A mixture of  $\text{H}_2(\text{g})$ ,  $\text{I}_2(\text{g})$  and  $\text{HI}(\text{g})$  are in dynamic equilibrium at a pressure of 2 atmospheres and 200 °C.  
 The temperature of the mixture is **increased** to 500 °C but the pressure remains unchanged.  
 Explain why the mixture becomes less purple in colour. [3]

**SOLUTION**

- (b)** Since the reaction is endothermic, increase in temperature favors forward reaction and more HI is produced. Since  $\text{I}_2$  is being used, the purple color of  $\text{I}_2$  gradually fades.

**58** [J12/P2/QB9/b]

Methanol,  $\text{CH}_3\text{OH}$ , is manufactured from carbon dioxide and hydrogen.

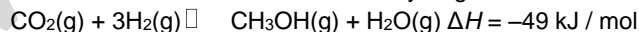

The reaction is carried out in the presence of a catalyst containing copper. The conditions used are 70 atmospheres pressure and a temperature of 250 °C.

- (b)** If the pressure of the reaction mixture is **decreased** to 50 atmospheres, explain what happens to the position of equilibrium. [2]



**SOLUTION**

- (b) Position of equilibrium shifts to the left because more moles of gas are present on the left hand side  
(Decrease in pressure favours that side of reaction which has more moles of gas)

**59 [J13/P2/QB9/b,c]**

Methane reacts with water to produce hydrogen and carbon monoxide.

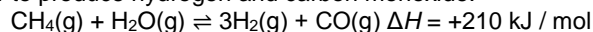

This reaction is endothermic.

The reaction is normally carried out at a pressure of 30 atmospheres and a temperature of 850 °C.

- (b) The reaction is carried out at **50 atmospheres** rather than 30 atmospheres, and at 850 °C.  
Predict and explain the effect of raising the pressure on the position of equilibrium. [2]
- (c) The reaction uses a catalyst.  
(i) What effect does a catalyst have on the position of equilibrium? [1]  
(ii) Explain how a catalyst causes the rate of reaction to increase. [1]

**SOLUTION**

- (b) Since there are fewer moles there, reaction shifts to the left side.  
(raising the pressure shifts the equilibrium to a side with fewer moles)
- (c) (i) No effect  
(ii) A catalyst lowers the activation energy of a reaction.

**60 [N13/P2/QB8/a]**

When hydrogen iodide, HI, is heated in a closed tube, the following dynamic equilibrium is established.

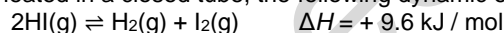

- (a) What is meant by the term *dynamic equilibrium*? [2]

**SOLUTION**

- (a) A closed system is said to be in dynamic equilibrium when the rate of forward reaction equals the rate of backward reaction

**61 [J14/P2/QB9/c]**

- (c) Describe and explain what happens, if anything, to the position of equilibrium when the pressure is increased. The temperature remains constant. [2]

**SOLUTION**

- (c) Position of equilibrium does not change because number of moles of gas on both sides of the equation are same.

**62 [N14/P2/QB9/a,b,c,d]**

Ammonia is manufactured by the Haber process.

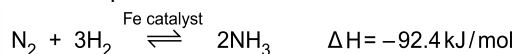

The table below shows how the percentage yield of ammonia at equilibrium varies with both temperature and pressure.

| pressure / atmospheres | % yield at 200 °C | % yield at 300 °C | % yield at 400 °C | % yield at 500 °C |
|------------------------|-------------------|-------------------|-------------------|-------------------|
| 30                     | 68                | 32                | 11                | 4                 |
| 100                    | 81                | 51                | 25                | 10                |
| 200                    | 86                | 63                | 36                | 18                |
| 300                    | 88                | 69                | 40                | 24                |

- (a) Describe how, and explain why, the percentage yield of ammonia at equilibrium changes with temperature. [2]
- (b) Describe how, and explain why, the percentage yield of ammonia at equilibrium changes with pressure. [2]
- (c) Explain why the conditions for the synthesis of ammonia in most chemical plants are between 350–450 °C and 200–300 atmospheres pressure. [2]
- (d) Explain how using a catalyst in the Haber process has an economic advantage. [2]

### SOLUTION

- (a) Percentage yield of ammonia decreases with increase in temperature. This is because the reaction is exothermic and increasing temperature favours the reaction which absorbs heat (*Backward reaction absorbs heat and is favoured*)
- (b) Percentage yield of ammonia increases with increasing pressure because increasing pressure causes the reaction to go in the direction of decreasing number of moles and, hence, the position of equilibrium shifts to right (*Right side has 2 moles of gas while left side has 3*)
- (c) 350–450 °C is the optimum temperature for this reaction because too low temperature makes reaction rate too slow but too high a temperature decreases the percentage yield of ammonia. 200–300 atmospheres pressure is the optimum temperature for this reaction because too low pressure gives poor yield of ammonia but too high a pressure consumes too much energy
- (d) Using a catalyst speeds up the reaction by lowering the activation energy barrier. Since less energy is used, it lowers the energy costs.

63

[J15/P2/QA2/c]

Hydrogen reacts with halogens to form hydrogen halides.

- (c) Hydrogen reacts with iodine in a reversible reaction.  
This reaction reaches an equilibrium if carried out in a closed system.

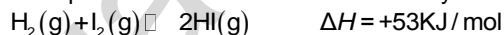

- (i) The reaction is studied at a temperature of 400 °C.  
Describe and explain what happens to the position of equilibrium if the pressure is increased. [2]
- (ii) The reaction is studied at 25 atmospheres pressure.  
Describe and explain what happens to the position of equilibrium if the temperature is decreased. [2]

**SOLUTION**

- (c) (i) The position of equilibrium remains unchanged because the numbers of moles of gas is equal on both the sides  
(increase in pressure shifts equilibrium to the side of the reaction with fewer moles of gas)
- (ii) If the temperature is decreased, the reaction will shift to the exothermic side to return the temperature to normal. Hence, the backward reaction is favored as it is exothermic

**64**

**[J16/P2/QB9/c]**

Carbon monoxide reacts with hydrogen in a reversible reaction.

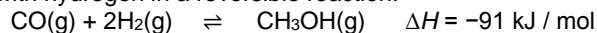

The reaction reaches an equilibrium if carried out in a closed container.

- (c) Predict, with a reason, how the **position of equilibrium** of this reaction changes as the
- (i) pressure is increased at constant temperature, [2]
- (ii) temperature is increased at constant pressure. [2]

**SOLUTION**

- (c) (i) Increasing the pressure favours the side of reaction with lesser number of moles. The equilibrium shifts to the right since the product side has less number of moles
- (ii) Increasing temperature favours endothermic reaction. The equilibrium shifts to the left since the backward reaction is endothermic

## UNIT-7 THE CHEMISTRY AND USES OF ACIDS, BASES AND SALTS

### 7.1 Properties Of Acids And Bases

#### 1 [J05/P2/QA1/c]

Choose from the following substances to answer the questions below.

aluminium oxide

ammonia

bariumsulphate

calcium carbonate

carbon monoxide

lead(II) iodide

nitrogen dioxide

silicon dioxide

(c) is amphoteric, [1]

#### SOLUTION

(c) Aluminium oxide  
(It reacts with both acids and alkalis)

#### 2 [J05/P2/QB10/g]

(g) Aqueous sodium hydroxide neutralizes dilute ethanoic acid.  
Write the ionic equation for this reaction. [1]

#### SOLUTION

(g)  $H^+ + OH^- \rightarrow H_2O$

#### 3 [N05/P2/QA3]

This table shows the soil pH ranges required by different crops for growth

| crop pH range | pH range  |
|---------------|-----------|
| peanut        | 5.0 – 6.5 |
| millet        | 6.0 – 6.5 |
| sunflower     | 6.0 – 7.5 |
| paprika       | 7.0 – 8.5 |
| mango         | 5.5 – 6.0 |

- (a) A farmer plants peanut and millet crops. Only the peanut crop grows well.  
Predict the pH of the soil. [1]
- (b) Which other crop is most likely to grow well in the same soil? [1]
- (c) The farmer adds calcium hydroxide,  $Ca(OH)_2$ , and ammonium sulphate,  $(NH_4)_2SO_4$ , to the soil.  
Explain the purpose of using each compound. [3]
- (d) A reaction occurs between calcium hydroxide and ammonium sulphate.  
(i) Complete the equation for this reaction.  
 $Ca(OH)_2 + (NH_4)_2SO_4 \rightarrow \dots + \dots + 2H_2O$   
(ii) Explain why the farmer should not have added these two compounds to the soil at the same time. [3]

#### SOLUTION

- (a) The pH of the soil is between 5.0 -5.9
- (b) Mango crop  
(It has almost the same pH as the soil)
- (c)  $Ca(OH)_2$  neutralizes the acidic soil by reacting with  $H^+$  ions in the soil

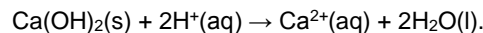

(Ca(OH)<sub>2</sub> is a weak alkali)

(NH<sub>4</sub>)<sub>2</sub>SO<sub>4</sub> serves as a nitrogenous fertilizer to increase plant growth

((NH<sub>4</sub>)<sub>2</sub>SO<sub>4</sub> is a source of nitrogen)

- (d) (i)  $\text{Ca(OH)}_2 + (\text{NH}_4)_2\text{SO}_4 \rightarrow \text{CaSO}_4 + 2\text{NH}_3 + 2\text{H}_2\text{O}.$   
 (ii) Ammonium compounds such as (NH<sub>4</sub>)<sub>2</sub>SO<sub>4</sub> react with alkalis, under the heat of sun to release ammonia gas which results in the loss of nitrogen content of the soil  
 $2\text{NH}_4^+(\text{aq}) + \text{Ca(OH)}_2(\text{s}) \rightarrow 2\text{NH}_3(\text{g}) + \text{Ca}^{2+}(\text{aq}) + 2\text{H}_2\text{O}(\text{l}).$

4

[N06/P2/QA1/a(ii)]

The diagram shows the structures of various compounds.

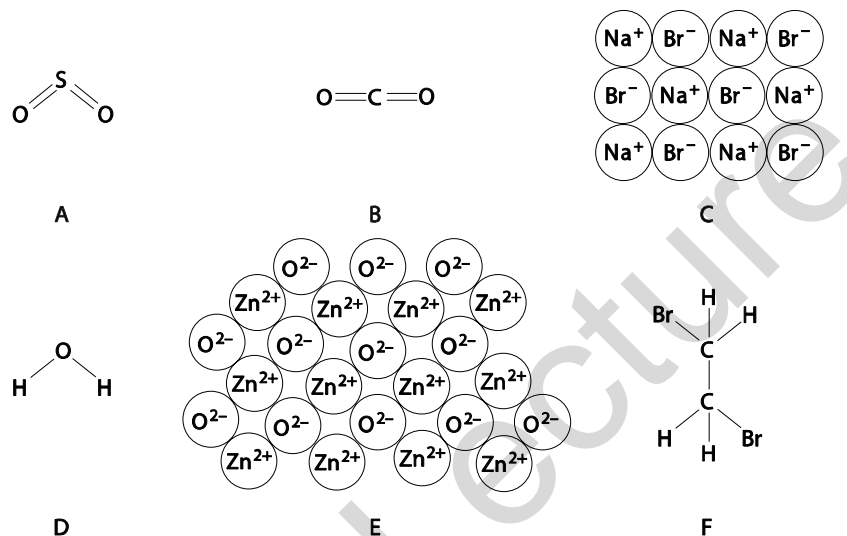

- (a) (ii) Which **one** of these compounds is an amphoteric oxide? [1]

**SOLUTION**

- (a) (ii) E  
 (CO<sub>2</sub> and SO<sub>2</sub> are acidic oxides)

5

[N06/P2/QA5/d]

- (d) Calcium hydroxide is added to neutralise the acidic solution formed after chlorine has been added. This solution contains hydrochloric acid.  
 (i) Write an equation for the reaction of calcium hydroxide with hydrochloric acid. [1]  
 (ii) Write the ionic equation for this reaction. [1]

**SOLUTION**

- (d) (i)  $\text{Ca(OH)}_2 + 2\text{HCl} \rightarrow \text{CaCl}_2 + 2\text{H}_2\text{O}.$   
 (ii)  $\text{OH}^- + \text{H}^+ \rightarrow \text{H}_2\text{O}.$   
 (Ca<sup>2+</sup> and Cl<sup>-</sup> ion are spectator ions)

6

[J07/P2/QA1/c]

Choose from the following oxides to answer the questions below.

aluminium oxide      calcium oxide      carbon monoxide      copper(II) oxide  
sulphur dioxide      sulphur trioxide      vanadium(V) oxide

Each oxide can be used once, more than once or not at all.

Name an oxide which

(c) reacts with dilute sulphuric acid to give a blue solution, [1]

**SOLUTION**

(c) Copper (II) oxide  
(CuSO<sub>4</sub> forms which is blue in color)

7

[N07/P2/QA3/b(iii),c]

(b) (iii) Hydrochloric acid reacts with magnesium germanide, Mg<sub>2</sub>Ge, to form germanomethane, GeH<sub>4</sub>, and magnesium chloride. [1]  
Write an equation for this reaction.

(c) Germanium(IV) oxide, GeO<sub>2</sub>, is an amphoteric oxide. [1]  
What do you understand by the term *amphoteric*?

**SOLUTION**

(b) (iii)  $Mg_2Ge + 4HCl \rightarrow 2MgCl_2 + GeH_4$ .  
(c) Amphoteric oxide refers to an oxide which has the properties of both an acid and a base and can react as either

8

[J08/P2/QA1/b]

Choose from the following gases to answer the questions below.

Ammonia      argon      carbon monoxide      chlorine  
Hydrogen      nitrogen      nitrogen dioxide      oxygen

Each gas can be used once, more than once or not at all.

Name a gas which

(b) dissolves in water to make an alkaline solution, [1]

**SOLUTION**

(b) Ammonia  
(Ammonia dissolves in water to produce OH<sup>-</sup> ions)

9

[J08/P2/QB9/a,c]

Dilute ethanoic acid and dilute hydrochloric acid both react with magnesium ribbon to form hydrogen.

(a) Give the formula of one ion found in both of these dilute acids. [1]

(c) (i) Write an equation for the reaction between dilute ethanoic acid and sodium carbonate. [1]

(ii) What observations would be made during this reaction? [1]

**SOLUTION**

(a) H<sup>+</sup> / H<sub>3</sub>O<sup>+</sup>  
(c) (i)  $2CH_3COOH + Na_2CO_3 \rightarrow 2CH_3COONa + CO_2 + H_2O$

- (ii) Bubbles of gas will be seen  
(Other possible answer: Sodium carbonate will dissolve)

10

[N08/P2/QA1/(vi)]

The diagram shows part of the Periodic Table.

|    |    |    |    |    |    |    |    |    |    |    |    |
|----|----|----|----|----|----|----|----|----|----|----|----|
|    |    |    |    |    |    |    |    |    |    | He |    |
|    |    |    |    |    |    | B  | C  | N  | O  | F  | Ne |
|    |    |    |    |    |    | A/ | Si | P  | S  | Cl | Ar |
| Fe | Co | Ni | Cu | Zn | Ga | Ge | As | Se | Br | Kr |    |
|    |    |    |    |    |    |    |    |    | I  | Xe |    |

Answer these questions using **only** the elements shown in the diagram.

Each element can be used once, more than once or not at all.

Write the symbol for

- (vi) two elements which combine to form a compound which causes acid rain. [1]

**SOLUTION**

- (vi) S and O  
(SO<sub>2</sub> dissolves in water producing H<sub>2</sub>SO<sub>4</sub> causing acid rain.  
Other possible answer: N and O)

11

[N08/P2/QA4/b]

- (b) Phosphorus(V) oxide, P<sub>2</sub>O<sub>5</sub>, absorbs water from the air to form meta-phosphoric acid, HPO<sub>3</sub>.  
(i) Write an equation for this reaction. [1]  
(ii) On addition of more water, phosphoric acid is formed. Phosphoric acid has typical acidic properties. What would you observe when aqueous phosphoric acid is added to aqueous sodium carbonate, blue litmus paper? [2]

**SOLUTION**

- (b) (i)  $P_2O_5 + H_2O \rightarrow 2HPO_3$ .  
(ii) **Aqueous sodium carbonate:** Bubbles of gas  
**Blue litmus paper:** litmus turns to red

12

[N08/P2/QA5/a(ii),b(i,ii)]

Cement is made by heating clay with crushed calcium carbonate. During this process, the calcium carbonate is first converted to calcium oxide.

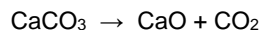

- (a) (ii) Suggest why calcium oxide is used to neutralise acidic soils. [1]  
(b) (i) Write an equation for this reaction. [1]  
(ii) The aqueous calcium hydroxide in wet concrete reacts with carbon dioxide in the air.

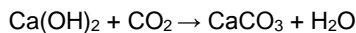

The diagram shows the pH at various points inside a cracked concrete beam.

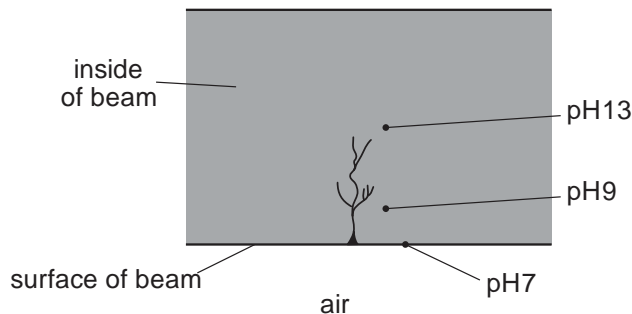

Describe and explain the change in pH from the surface to the centre of the beam. [3]

**SOLUTION**

- (a) (ii) It is a basic oxide and helps to neutralize acidic soil  
 (CaO produces OH<sup>-</sup> ions in aqueous solutions)
- (b) (i)  $\text{CaO} + \text{H}_2\text{O} \rightarrow \text{Ca(OH)}_2$
- (ii) At the surface of the concrete beam, (CaOH)<sub>2</sub> reacts with CO<sub>2</sub> and changes into calcium carbonate lowering the pH at the surface. (CaOH)<sub>2</sub> deeper in the concrete does not come in contact with CO<sub>2</sub> and acts as an alkali resulting in pH 9 and pH 13 depending on the depth inside the concrete beam.  
 (CO<sub>2</sub> is acidic in aqueous solutions)

**13 [N08/P2/QA6/a(ii)]**

Electrolysis is used to produce many important chemicals such as chlorine, sodium hydroxide and aluminium.

- (a) Chlorine is used in both water treatment and as a bleach.
- (ii) Name a substance, other than chlorine, that is used to bleach wood pulp. [1]

**SOLUTION**

- (a) (ii) Sulphur dioxide  
 (Other possible answers: Calcium hypochlorite, hydrogen peroxide).

**14 [N08/P2/QB8/b(iii)]**

- (b) Sorrel plants contain a poisonous carboxylic acid X.  
 What can be deduced about X from each of the following three pieces of information?
- (iii) A 0.1 mol/dm<sup>3</sup> solution of X has a pH of 3 whereas a 0.1 mol/dm<sup>3</sup> solution of hydrochloric acid has a pH of 1. [1]

**SOLUTION**

- (b) (iii) pH of 3 indicates that X is a weak acid



15

[J09/P2/QA1/c]

Choose from the following substances to answer the questions below.

**copper(II) chloride**                      **chlorine**                      **ethanoic acid**                      **hydrochloric acid**  
**manganese(IV) oxide**                      **platinum**                      **potassium dichromate(VI)**  
**sodium chloride**                      **sulfuric acid**                      **vanadium(V) oxide**

Each substance can be used once, more than once or not at all.

Name a substance which

(c) is a weak acid, [1]

**SOLUTION**

(c) Ethanoic acid  
(HCl and H<sub>2</sub>SO<sub>4</sub> are strong acids)

16

[J09/P2/QA6/b]

The table shows the concentration of different ions found in a sample of aqueous industrial waste.

| ion                          | concentration<br>in mol/dm <sup>3</sup> |
|------------------------------|---|
| Ca <sup>2+</sup>             | 0.125                                   |
| H <sup>+</sup>               | 2.30                                    |
| K <sup>+</sup>               | 0.234                                   |
| NO <sub>3</sub> <sup>-</sup> | 3.68                                    |
| Fe <sup>2+</sup>             | 0.450                                   |

Use the information in the table to answer the following questions.

(b) Is the sample of aqueous waste acidic, neutral or alkaline? Explain your answer. [1]

**SOLUTION**

(b) It is acidic because of the presence of H<sup>+</sup> ions

17

[N09/P2/QA1/a(iii,v.vi)]

(a) Choose from the following compounds to answer the questions below.

**ammonium sulfate**                      **calcium oxide**                      **copper(II) chloride**  
**ethanoic acid**                      **ethane**                      **nitrogen dioxide**  
**sodium iodide**                      **sulfur dioxide**

Each compound can be used once, more than once or not at all.

Which compound

(iii) is used as a fertiliser, [1]

(v) is used by farmers to reduce soil acidity, [1]

(vi) forms an alkaline solution when it reacts with water? [1]

**SOLUTION**

(a) (ii) Sodium iodide  
(iii) Ammonium sulfate  
(v) Calcium oxide  
(Calcium oxide is basic and hence reduces acidity)  
(vi) Calcium oxide  
(CaO dissolves in water to produce an alkali, Ca(OH)<sub>2</sub>)

**18**

**[N09/P2/QA4/a,b]**

Methylamine,  $\text{CH}_3\text{NH}_2$ , is a base which has similar properties to ammonia.  
When methylamine dissolves in water, the following equilibrium is set up.

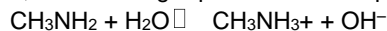

- (a) Explain why methylamine behaves as a base in this reaction. [1]  
(b) When aqueous methylamine is added to aqueous iron(III) chloride, a red-brown precipitate is observed.  
Suggest what you would observe when aqueous methylamine is added to aqueous iron(II) chloride. [1]

**SOLUTION**

- (a) It dissolves in water to produce hydroxide ions  
(Methylamine acts as a proton acceptor like other bases)  
(b) Grey-green precipitate  
(Iron (II) hydroxide is produced)

**19**

**[J10/P2/QB7/d(i)]**

- (d) Hydrazine,  $\text{N}_2\text{H}_4$ , has similar chemical properties to ammonia.  
(i) Hydrazine reacts with hydrochloric acid. Suggest the formula of the product of this reaction. [1]

**SOLUTION**

- (d) (i)  $\text{N}_2\text{H}_5\text{Cl}$

**20**

**[N10/P2/QA4/d]**

- (d) Hydrochloric acid can be made by burning hydrogen in chlorine, then dissolving the product in water.  
Give the formulae for the ions present in hydrochloric acid. [1]

**SOLUTION**

- (d)  $\text{H}^+$ ,  $\text{Cl}^-$  and  $\text{OH}^-$   
 $\text{H}^+$  and  $\text{Cl}^-$  from  $\text{HCl}$  and  $\text{H}^+$  and  $\text{OH}^-$  from water

**21**

**[N10/P2/QB8/a]**

Magnesium is a reactive metal.

- (a) (ii) Write the equation for the reaction of magnesium with ethanoic acid,  $\text{CH}_3\text{COOH}$ . [2]

**SOLUTION**

- (a) (ii)  $2\text{CH}_3\text{COOH} + \text{Mg} \rightarrow (\text{CH}_3\text{COO})_2\text{Mg} + \text{H}_2$

**22**

**[J11/P2/QB8/a,b]**

Propanoic acid,  $\text{C}_2\text{H}_5\text{CO}_2\text{H}$ , and hydrochloric acid,  $\text{HCl}$ , both act as acids when dissolved in water.

- (a) State the formula of an ion found in both dilute propanoic acid and in dilute hydrochloric acid. [1]  
(b) Propanoic acid reacts with magnesium carbonate to form water, a colourless gas and a salt. In this reaction  
(i) name the gas, [1]

- (ii) give the formula of the salt. [1]

**SOLUTION**

- (a) H<sup>+</sup>  
(b) (i) CO<sub>2</sub>  
**Acid reacts with metal carbonates to give a salt, water and CO<sub>2</sub>**  
(ii) Mg(C<sub>2</sub>H<sub>5</sub>CO<sub>2</sub>)<sub>2</sub>

**23 [N11/P2/QA1/a]**

Choose from the following list of elements to answer the questions below.

**Calcium**      **chlorine**      **hydrogen**      **iodine**  
**Nickel**      **sodium**      **vanadium**      **zinc**

Each element can be used once, more than once, or not at all.

Which element

- (a) forms an oxide which is amphoteric, [1]

**SOLUTION**

- (a) Zinc  
**Oxides of zinc, aluminium and lead(ZAL) are amphoteric**

**24 [N11/P2/QB7/a]**

Sulfuric acid is a strong acid. Ethanoic acid is a weak acid.

- (a) What do you understand by the terms *strong acid* and *weak acid*? [1]

**SOLUTION**

- (a) Strong acid ionizes completely in water while weak acid ionizes partially in water.

**25 [N11/P2/QB9/a]**

Barium is a reactive metal in Group II of the Periodic Table.

Barium reacts with water in a similar way to sodium. The products of the reaction are aqueous barium hydroxide and a colourless gas.

- (a) (i) Write an equation, including state symbols, for this reaction. [3]  
(ii) Aqueous barium hydroxide is neutralised by hydrochloric acid.  
Write the simplest ionic equation for this reaction. [1]

**SOLUTION**

- (a) (i)  $\text{Ba}_{(s)} + 2\text{H}_2\text{O}_{(l)} \rightarrow \text{Ba}(\text{OH})_{2(aq)} + \text{H}_{2(g)}$   
(ii)  $\text{H}^+ + \text{OH}^- \rightarrow \text{H}_2\text{O}$   
**(H<sup>+</sup> from acids and OH<sup>-</sup> from alkalis react together to produce water)**

**26 [N12/P2/QA1/b(ii,iii)]**

(b) Choose from the following compounds to answer the questions below.

|                          |                       |                        |                     |
|--------------------------|-----------------------|------------------------|---------------------|
| <b>calcium carbonate</b> | <b>carbon dioxide</b> | <b>carbon monoxide</b> | <b>ethane</b>       |
| <b>glucose</b>           | <b>methane</b>        | <b>propane</b>         | <b>sodium oxide</b> |
| <b>sucrose</b>           | <b>water</b>          | <b>zinc oxide</b>      |                     |

Each compound can be used once, more than once or not at all.

Which compound

- (ii) reacts with both hydrochloric acid and aqueous sodium hydroxide, [1]  
(iii) reacts with hydrochloric acid to form a gas which turns limewater milky, [1]

**SOLUTION**

- (b) (ii) ZnO  
(ZnO is an amphoteric oxide)  
(iii) CaCO<sub>3</sub>  
(Metal carbonates react with acid to form a salt, water and CO<sub>2</sub>. CO<sub>2</sub> turns limewater milky)

**27**

**[N12/P2/QB6/a(ii)]**

Seawater contains chloride, bromide and iodide ions.

Bromine can be manufactured by bubbling chlorine through seawater.

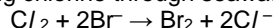

- (a) (ii) Describe how you could determine the pH of the resulting solution. [1]

**SOLUTION**

- (a) (ii) It can be measured by using universal indicator  
(Other possible options: use pH paper and compare with color chart, use of pH meter, use of pH electrode)

**28**

**[N12/P2/QB8/a,b,c(ii),d]**

Many fertilisers contain phosphate ions and nitrate ions.

- (a) Explain why farmers put fertilisers on the soil. [1]  
(b) Why should the chemicals in fertilisers be soluble in water? [1]  
(c) (ii) Describe how crystals of ammonium sulfate can be prepared from aqueous ammonia. [4]  
(d) The formula of calcium phosphate is Ca<sub>3</sub>(PO<sub>4</sub>)<sub>2</sub>.  
Use this formula to deduce the charge on the phosphate ion. [1]

**SOLUTION**

- (a) To improve crop growth and yield  
(b) The chemicals should be soluble in water so that the roots can absorb them  
(c) (ii) Add sulfuric acid to aqueous ammonia, titration method using a suitable indicator such as phenolphthalein. Note the volume of acid used when the end point is reached. Repeat this procedure without using the indicator. Heat the obtained solution to crystallization point and by slow cooling to get crystals of ammonium sulfate  
(d) 3-

**29**

**[N12/P2/QB9/d]**

- (d) Compounds containing hydroxide ions can be added to the soil to reduce its acidity.  
(i) Explain why adding hydroxide ions to the soil can cause the loss of nitrogen from fertilisers containing ammonium salts. [1]  
(ii) Construct an ionic equation for this reaction. [1]

**SOLUTION**

- (d) (i) Hydroxides react with ammonium salts to form ammonia gas which escapes in the atmosphere resulting in loss of nitrogen content of the soil  
(ii)  $\text{OH}^- + \text{NH}_4^+ \rightarrow \text{NH}_3 + \text{H}_2\text{O}$

**30 [J13/P2/QB7/b(i)]**

- (b) (i) Write equations for the reactions of HCl with  $\text{Mg}(\text{OH})_2$  and also with  $\text{CaCO}_3$ .  
 $\text{Mg}(\text{OH})_2$   
 $\text{CaCO}_3$  [2]

**SOLUTION**

- (b) (i)  $\text{Mg}(\text{OH})_2 + 2\text{HCl} \rightarrow \text{MgCl}_2 + 2\text{H}_2\text{O}$   
 $\text{CaCO}_3 + 2\text{HCl} \rightarrow \text{CaCl}_2 + \text{CO}_2 + \text{H}_2\text{O}$

**31 [N13/P2/QA4/c,d]**

- (c) Carbon dioxide dissolves in water to form a weakly acidic solution.  
 $\text{CO}_2(\text{g}) + \text{H}_2\text{O}(\text{l}) \rightleftharpoons \text{HCO}_3^-(\text{aq}) + \text{H}^+(\text{aq})$   
(i) What is the meaning of the term *weak acid*? [1]  
(ii) Describe how you could measure the pH of this solution other than by using a pH meter. [2]  
(d) Sodium hydrogencarbonate,  $\text{NaHCO}_3$ , decomposes on heating to form a carbonate, water and a gas which turns limewater milky.  
Construct an equation for this reaction. [2]

**SOLUTION**

- (c) (i) Weak acid refers to an acid that ionizes/dissociates incompletely in water  
(ii) Add universal indicator to the solution and compare the color of the solution with the color in the indicated color chart  
(d)  $2\text{NaHCO}_3 \rightarrow \text{Na}_2\text{CO}_3 + \text{CO}_2 + \text{H}_2\text{O}$ .

**32 [N13/P2/QA5/a]**

- A student reacts magnesium ribbon with excess hydrochloric acid.  
She follows the course of the reaction by measuring the volume of gas produced against time.  
(a) Write the equation for the reaction of magnesium with hydrochloric acid. [1]

**SOLUTION**

- (a)  $\text{Mg} + 2\text{HCl} \rightarrow \text{MgCl}_2 + \text{H}_2$ .

**33 [N13/P2/QB9/a,b,c]**

- The compounds ammonium nitrate and ammonium sulfate are both fertilisers.  
(a) Explain why farmers add these fertilisers to soils. [1]  
(b) Ammonium sulfate can be prepared by adding sulfuric acid to aqueous ammonia.  
Construct the equation for this reaction. [1]  
(c) Excess acidity in soils can be treated by adding calcium hydroxide.  
(i) Give the formula of the ion present in calcium hydroxide which causes it to be alkaline. [1]  
(ii) Explain why adding calcium hydroxide causes loss of nitrogen from fertilizers such as ammonium nitrate, which have been previously added to the soil. [2]



**36**

**[N14/P2/QA2/c]**

- (c) Sodium and calcium form ionic hydrides containing the hydride ion, H<sup>-</sup>.  
Sodium and calcium hydrides react with water to form the hydroxide and hydrogen.

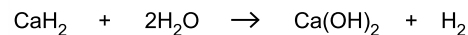
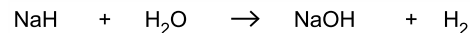

Deduce the general ionic equation for these reactions. [1]

**SOLUTION**

- (c)  $\text{H}^- + \text{H}_2\text{O} \rightarrow \text{OH}^- + \text{H}_2$ .

**37**

**[N14/P2/QA4/a,c]**

Sulfuric acid reacts with the alkali sodium hydroxide.

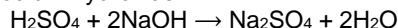

- (a) Write the ionic equation for this reaction. [1]

- (c) The experiment was repeated using ethanoic acid of the same concentration as the sulfuric acid.  
The same volume and concentration of aqueous sodium hydroxide was used.

- (i) The volume of ethanoic acid required to neutralise the aqueous sodium hydroxide was twice as great compared with the volume of sulfuric acid.  
Explain why. [1]

- (ii) Suggest the value of the pH after excess ethanoic acid has been added. [1]

**SOLUTION**

- (a)  $\text{H}^+ + \text{OH}^- \rightarrow \text{H}_2\text{O}$ .

- (c) (i) Ethanoic acid has 1 mol of ionisable H<sup>+</sup> per mol of acid but  
H<sub>2</sub>SO<sub>4</sub> has 2 ionisable H<sup>+</sup> per mol of acid  
(Ethanoic acid is monobasic but H<sub>2</sub>SO<sub>4</sub> is dibasic)

- (ii) 3  
(Any value between 3 to 6 is acceptable)

**38**

**[N14/P2/QB6/e]**

- (e) Chlorine reacts with excess ammonia, NH<sub>3</sub>, to form hydrogen chloride and nitrogen.  
Construct an equation for this reaction. [1]

**SOLUTION**

- (e)  $2\text{NH}_3 + 3\text{Cl}_2 \rightarrow \text{N}_2 + 6\text{HCl}$ .

**39**

**[N14/P2/QB7/e(ii)]**

- (e) Hydrogen cyanide, HCN, is manufactured by reacting methane with ammonia and oxygen.

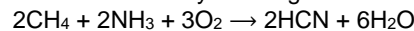

- (ii) Hydrogen cyanide reacts with calcium hydroxide to form calcium cyanide and water.  
The formula of the cyanide ion is CN<sup>-</sup>.  
Construct the equation for this reaction. [1]

**SOLUTION**

- (e) (ii)  $\text{Ca(OH)}_2 + 2\text{HCN} \rightarrow \text{Ca(CN)}_2 + 2\text{H}_2\text{O}$ .

40

[J15/P2/QA4]

The flow chart shows some reactions of iron(II) sulfate, FeSO<sub>4</sub>.

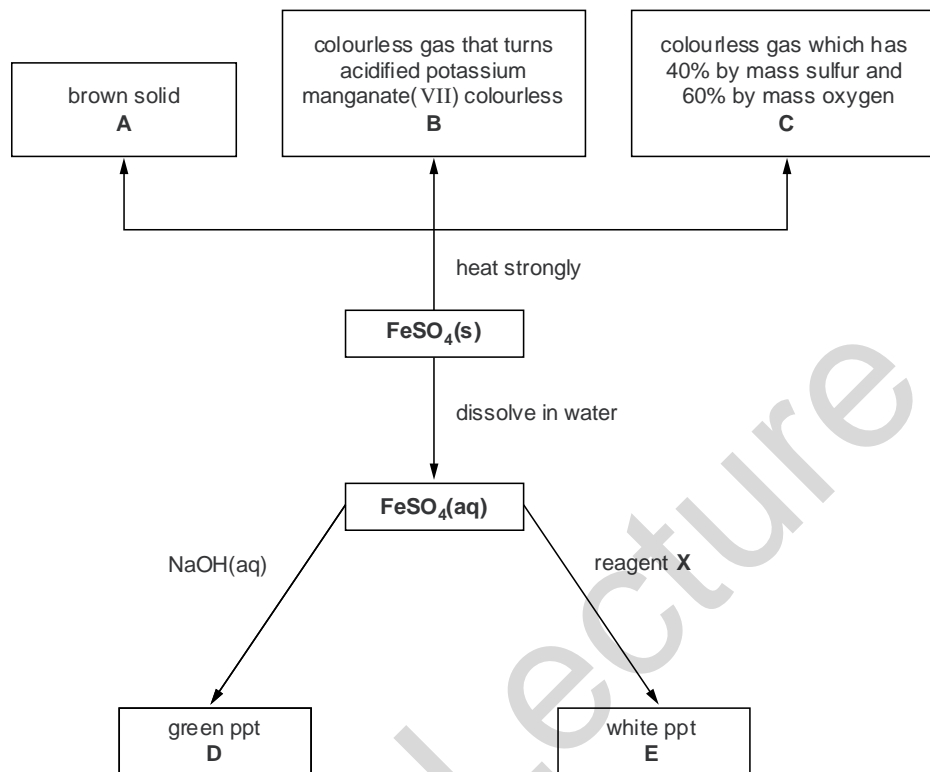

- (a) Iron (II) sulfate is heated strongly.
- (i) Write the formula of gas B. [1]
- (ii) Calculate the empirical formula of gas C. Name gas C. empirical formula is name [3]
- (iii) Two moles of iron(II) sulfate decompose to form one mole of solid A, one mole of gas B and one mole of gas C. Deduce the formula of solid A. formula of A [1]
- (b) Write an ionic equation, including state symbols, for the formation of the green precipitate D. [2]
- (c) Suggest the name of reagent X and give the formula for the white precipitate E. name of reagent X formula of precipitate E [2]

**SOLUTION**

- (a) (i)  $\text{SO}_2 + (2\text{FeSO}_4 \rightarrow \text{Fe}_2\text{O}_3 + \text{SO}_2 + \text{SO}_3)$   
(ii)



|                  | S               | O               |
|------------------|-----------------|-----------------|
| %age ratio       | 40              | 60              |
| Atomic mass      | 32              | 16              |
| Molar ratio      | $40/32 = 1.25$  | $60/16 = 3.75$  |
| Simplified ratio | $1.25/1.25 = 1$ | $3.75/1.25 = 3$ |

empirical formula is:  $\text{SO}_3$

name: Sulfur trioxide

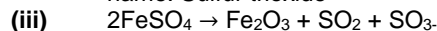

Formula of A:  $\text{Fe}_2\text{O}_3$

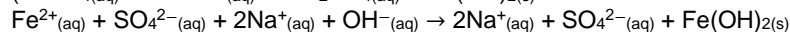
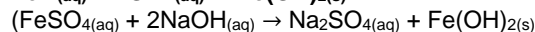

Cancelling off spectator ions

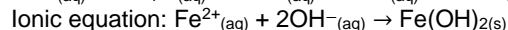
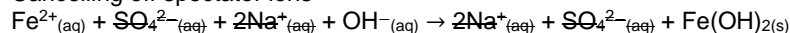

(barium salts are insoluble)

41

[J15/P2/QB6]

Ammonium carbonate,  $(\text{NH}_4)_2\text{CO}_3$ , is a white solid that is a component of 'smelling salts'.

It decomposes when it is heated.

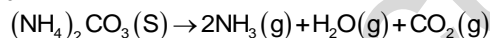

- (a) A sample of ammonium carbonate is heated strongly until it all decomposes. Suggest what you would observe during the experiment. [1]
- (b) Describe how you would show that both ammonia and carbon dioxide are formed in this decomposition. [4]
- (c) Ammonium carbonate is soluble in water but zinc carbonate is insoluble in water. Describe how you would prepare a sample of pure, dry zinc carbonate using a solution of ammonium carbonate. [3]
- (d) Excess ammonium carbonate reacts with phosphoric acid,  $\text{H}_3\text{PO}_4$ . Construct an equation for this reaction. [2]

### SOLUTION

- (a) White solid of ammonium carbonate disappears, pungent smell of ammonia and condensation of gases can be seen in the form of colourless droplets
- (b) Ammonia can be tested with moist red litmus which is turned blue. Carbon dioxide can be tested with limewater which is turned milky
- (c) Take  $100\text{cm}^3$  ammonium carbonate in a  $250\text{cm}^3$  beaker and add a soluble zinc compound such as zinc chloride or zinc sulfate. Filter the mixture, collect the residual insoluble zinc carbonate, wash with water and air dry it.
- (d)  $3(\text{NH}_4)_2\text{CO}_3 + 2\text{H}_3\text{PO}_4 \rightarrow 2(\text{NH}_4)_3\text{PO}_4 + 3\text{CO}_2 + 3\text{H}_2\text{O}$

42

[J16/P2/QB7/a,b,d]

The formula of lead(II) nitrate is  $\text{Pb}(\text{NO}_3)_2$ .

- (a) Describe how a pure sample of lead(II) nitrate crystals can be prepared from lead(II) oxide, which is insoluble in water. [4]

- (b) Aqueous potassium iodide is added to a sample of aqueous lead(II) nitrate. A precipitate of lead(II) iodide is formed.  
Construct the ionic equation, with state symbols, for this reaction. [2]
- (d) On heating, lead(II) nitrate decomposes to form PbO, NO<sub>2</sub> and O<sub>2</sub>.  
Construct the equation for this reaction. [1]

### SOLUTION

- (a) Lead (II) nitrate can be prepared by the reaction of lead (II) oxide with nitric acid. Take excess lead (II) oxide in a beaker and add warm nitric acid to the beaker (lead (ii) oxide would be in excess so that all the acid would be neutralized). Allow the mixture to react and then filter the mixture to get filtrate. Evaporate the filtrate to saturation point and allow it to cool slowly then crystallize would form and these would be dried between the folds of filter paper.
- (b)  $Pb^{2+}_{(aq)} + 2I^{-}_{(aq)} \rightarrow PbI_{2(s)}$   
 $(Pb(NO_3)_2_{(aq)} + KI_{(aq)} \rightarrow PbI_2(s) + KNO_3_{(aq)})$   
 $Pb^{2+} + NO_3^{-} + K^{+} + I^{-} \rightarrow PbI_2 + K^{+} + NO_3^{-}$
- (d)  $2Pb(NO_3)_2 \rightarrow 2PbO + 4NO_2 + O_2$

## 7.2 Properties Of Salts

43

[J05/P2/QB8/c,d]

- (c) Construct the equation for the reaction between silver and copper (II) chloride. [1]
- (d) Aqueous copper (II) chloride reacts with aqueous sodium hydroxide to form a precipitate.  
(i) Write the ionic equation, including state symbols, for the precipitation reaction.  
(ii) What is the name and colour of the precipitate? [4]

### SOLUTION

- (c)  $Ag + CuCl_2 \rightarrow AgCl + CuCl$
- (d) (i)  $Cu^{2+}_{(aq)} + 2OH^{-}_{(aq)} \rightarrow Cu(OH)_2(s)$   
(ii) Name: Copper (II) hydroxide  
Colour: Blue green

44

[J06/P2/QB9/a,b]

Fertilisers are soluble salts containing one or more of the essential elements required for plant growth.

- (a) Ammonium chloride can be prepared by the reaction between aqueous ammonia and hydrochloric acid.  
Write an ionic equation for this reaction. [1]
- (b) State suitable reagents and outline the experimental procedure by which a pure sample of the fertiliser potassium chloride could be prepared in the laboratory. [4]

### SOLUTION

- (a)  $NH_3 + H^{+} \rightarrow NH_4^{+}$   
(Cl<sup>-</sup> is the spectator ion)
- (b) Reagents: Potassium hydroxide and hydrochloric acid Procedure: 25cm<sup>3</sup> of KOH is transferred to a conical flask using a pipette. A few drops of phenolphthalein are added to the conical flask. Then, HCl is poured into the conical flask using a burette little by little until end point is reached. Until the indicator phenolphthalein changes its color from pink to colorless. The volume of acid required to reach the end point is noted and the whole procedure is repeated without the use of indicator. The

solution in the conical flask is then heated over a Bunsen flame in a china dish. After partial evaporation then allowed to cool slowly. Crystals form and then they are dried between the folds of filter paper.

**45** **[J08/P2/QB7/c]**

- (c) Silver chloride is an insoluble salt.  
Outline the preparation of pure, dry silver chloride, starting from solid silver nitrate. [4]

**SOLUTION**

- (c) Firstly, sufficient water is added to silver nitrate to make its solution. Then it is added to a soluble chloride like aqueous sodium chloride or dilute hydrochloric acid. A white precipitate of silver chloride is formed. Filter the precipitate, wash it with distilled water until it is free of soluble reactant and dry it between the folds of a filter paper

**46** **[J09/P2/QA6/a]**

The table shows the concentration of different ions found in a sample of aqueous industrial waste.

| ion                          | concentration in mol/dm <sup>3</sup> |
|------------------------------|--------------------------------------|
| Ca <sup>2+</sup>             | 0.125                                |
| H <sup>+</sup>               | 2.30                                 |
| K <sup>+</sup>               | 0.234                                |
| NO <sub>3</sub> <sup>-</sup> | 3.68                                 |
| Fe <sup>2+</sup>             | 0.450                                |

Use the information in the table to answer the following questions.

- (a) Write the formula of one salt that could be obtained from the sample. [1]

**SOLUTION**

- (a) KNO<sub>3</sub>  
(Other possible answers: Ca(NO<sub>3</sub>)<sub>2</sub>/Fe(NO<sub>3</sub>)<sub>2</sub>)

**47** **[J09/P2/QB10/c]**

- (c) Potassium sulfate is a soluble salt.  
Outline the preparation of a pure, dry sample of potassium sulfate, starting from dilute sulfuric acid. [3]

**SOLUTION**

- (c) Take 25cm<sup>3</sup> of KOH in a titration flask with few drops of indicator such as phenolphthalein and titrate it against dilute H<sub>2</sub>SO<sub>4</sub>. Note down the volume of acid used when the end point is reached. Repeat this procedure without using the indicator. Heat the obtained mixture to crystallization point and cool slowly get the crystals of potassium sulfate. Dry these crystals between the folds of filter paper

**48** **[N09/P2/QB9/d(ii)]**

- (d) (ii) Name a carbonate compound which is soluble in water. [1]

**SOLUTION**

- (d) (ii) Sodium carbonate

**49**

**[J10/P2/QA1/d]**

- (d) is an insoluble salt, [1]

**SOLUTION**

- (d)  $\text{BaSO}_4$ ,  $\text{CaCO}_3$   
*Sulphates of calcium, lead and barium are insoluble.*

**50**

**[J10/P2/QB10/a,b(i),c,d]**

Fertilisers are used to promote plant growth and increase crop yield.

Three fertilisers are potassium chloride, potassium nitrate and ammonium phosphate.

- (a) Potassium nitrate is a soluble salt that can be prepared by reaction between an acid and an alkali.  
(i) Write an equation for the reaction of an acid with an alkali to prepare potassium chloride. [1]  
(ii) Describe the essential experimental details of this preparation of solid potassium chloride. [2]  
(iii) Write the formula for ammonium phosphate. [1]
- (c) A farmer adds excess calcium hydroxide to react with hydrogen ions in acidic soils. He then adds fertiliser to increase the nitrogen content of the soil.  
(i) Write an ionic equation to show the neutralisation of hydrogen ions by solid calcium hydroxide. [1]  
(ii) Suggest why the farmer should use potassium nitrate rather than ammonium phosphate to increase the nitrogen content of the soil. [1]
- (d) A scientist believes a water sample is contaminated by potassium nitrate. Describe a chemical test to confirm the presence of aqueous nitrate ions. [2]

**SOLUTION**

- (a) (i)  $\text{KOH} + \text{HCl} \rightarrow \text{KCl} + \text{H}_2\text{O}$   
Acid and alkali react to give salt and water  
(ii) Titrate HCl against KOH in the presence of an indicator. Appropriate amounts of HCl and KOH are determined by noting the end point when indicator changes color. Heat the determined amount of acid and alkali to dryness. Remaining solid will be KCl.
- (b) (i)  $(\text{NH}_4)_3\text{PO}_4$
- (c) (i)  $\text{Ca}(\text{OH})_2 + 2\text{H}^+ \rightarrow \text{Ca}^{2+} + 2\text{H}_2\text{O}$   
(ii) ammonium phosphate reacts with  $\text{Ca}(\text{OH})_2$  to produce ammonia which results in loss of nitrogen content.  
All ammonium compounds react with alkali to produce ammonia, salt and water.
- (d) Add NaOH and Al powder to the sample and heat. Ammonia gas will be produced turning red litmus blue.

**51**

**[N10/P2/QB8/b]**

- (b) Magnesium chloride is a soluble salt.  
Describe how you can make pure dry crystals of magnesium chloride from magnesium carbonate. [3]

**SOLUTION**

- (b) Add magnesium carbonate in dilute HCl pinch by pinch till no further effervescence is seen. Filter off excess the magnesium carbonate and heat the filtrate to crystallization point. Cool the mixture and separate the crystals by filtration. Dry these crystals.

52

[N11/P2/QB9/d]

- (d) Barium sulfate is an insoluble compound.  
Describe how a pure dry sample of barium sulfate is prepared from aqueous barium nitrate. [4]

**SOLUTION**

- (d) Barium nitrate is taken in a beaker and dilute Sulfuric is added gradually. White precipitates of barium sulfate are produced and the mixture is filtered off. Barium nitrate being insoluble is obtained as residue. The precipitates are washed with distilled water and then dried between the folds of filter paper.

**\*Explanations in Italics**

53

[J12/P2/QB7/d(ii),e]

- (e) Copper(II) chloride can be prepared by the reaction between copper (II) carbonate and hydrochloric acid.  
(i) Construct the ionic equation for this reaction. [1]  
(ii) Describe the essential practical details for the preparation of a crystalline sample of copper (II) chloride. [3]

**SOLUTION**

- (e) (i)  $\text{CO}_3^{2-} + \text{H}^+ \rightarrow \text{HCO}_3^-$   
(ii) Add an excess of copper (II) carbonate to hydrochloric acid and filter the solution. Evaporate the filtrate partially till crystallization point to obtain a crystalline sample of Copper (II) Chloride.

54

[N13/P2/QB9/e]

- (e) Describe how to obtain pure dry crystals of calcium chloride from an aqueous solution of calcium chloride. [2]

**SOLUTION**

- (e) The aqueous solution of calcium chloride is heated to a crystallization point, the crystals are filtered off and then dried between the folds of filter paper

55

[N14/P2/QB8/b,c]

- (b) Aqueous sodium hydroxide reacts with aqueous iron (II) sulfate,  $\text{FeSO}_4$ .  
Construct the ionic equation, with state symbols, for this reaction. [2]  
(c) Iron (II) sulfate can be prepared by reacting excess iron powder with sulfuric acid.  
Describe the essential practical details to prepare pure dry crystals of iron (II) sulfate. [2]

**SOLUTION**

- (b)  $\text{Fe}^{2+}(\text{aq}) + 2\text{OH}^-(\text{aq}) \rightarrow \text{Fe}(\text{OH})_2(\text{s})$ .  
(c) Iron powder is added to solution of sulphuric acid and excess iron is filtered off. The filtrate is heated to crystallisation point and is then left to crystallize. Finally, filter off crystals and dry them between the folds of filter paper

56

[J15/P2/QA2/d]

- (d) Hydrogen iodide dissolves in water to form hydroiodic acid,  $\text{HI}(\text{aq})$ .  
Hydroiodic acid is a strong acid.

- (i) Write an equation to show the dissociation of hydroiodic acid. [1]  
 (ii) Hydroiodic acid reacts with calcium. [1]  
 Write the equation for this reaction.  
 (iii) Hydroiodic acid reacts with sodium carbonate. [1]  
 Write the ionic equation for this reaction. [1]

**SOLUTION**

- (d) (i)  $\text{HI} \rightarrow \text{H}^+ + \text{I}^-$   
 (ii)  $\text{Ca} + 2\text{HI} \rightarrow \text{CaI}_2 + \text{H}_2$   
 (iii)  $\text{CO}_3^{2-} + 2\text{H}^+ \rightarrow \text{H}_2\text{O} + \text{CO}_2$   
 $(2\text{HI}_{(aq)} + \text{Na}_2\text{CO}_{3(aq)} \rightarrow \text{H}_2\text{O}_{(l)} + \text{CO}_{2(g)} + 2\text{NaI}_{(aq)})$   
 $2\text{H}^+_{(aq)} + 2\text{I}^-_{(aq)} + 2\text{Na}^+_{(aq)} + \text{CO}_3^{2-}_{(aq)} \rightarrow \text{H}_2\text{O}_{(l)} + \text{CO}_{2(g)} + 2\text{Na}^+_{(aq)} + 2\text{I}^-_{(aq)}$   
 Cut out the spectator ions:  
 $2\text{H}^+_{(aq)} + 2\text{I}^-_{(aq)} + 2\text{Na}^+_{(aq)} + \text{CO}_3^{2-}_{(aq)} \rightarrow \text{H}_2\text{O}_{(l)} + \text{CO}_{2(g)} + 2\text{Na}^+_{(aq)} + 2\text{I}^-_{(aq)}$   
 Ionic equation:  $2\text{H}^+_{(aq)} + \text{CO}_3^{2-}_{(aq)} \rightarrow \text{H}_2\text{O}_{(l)} + \text{CO}_{2(g)}$

**57**

**[J16/P2/QB10/d,e]**

Manganese(IV) oxide,  $\text{MnO}_2$ , can be used in the preparation of both chlorine and oxygen.

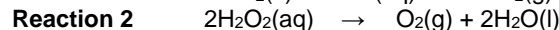
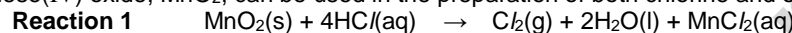

In **reaction 2** manganese(IV) oxide acts as a catalyst.

- (d) Chlorine is bubbled through aqueous iron(II) chloride to form iron(III) chloride. [4]  
 Explain, with the aid of equations, how aqueous sodium hydroxide can be used to distinguish between aqueous iron(II) chloride and aqueous iron(III) chloride. [4]  
 (e) Describe the chemical test for chlorine. [2]

**SOLUTION**

- (d) Both iron (II) chloride and iron (III) chloride form different coloured precipitates with sodium hydroxide.  
 $\text{FeCl}_2 + 2\text{NaOH} \rightarrow \text{Fe}(\text{OH})_2 + 2\text{NaCl}$   
 $\text{Fe}(\text{OH})_2$  gives a green precipitate  
 $\text{FeCl}_3 + 3\text{NaOH} \rightarrow \text{Fe}(\text{OH})_3 + 3\text{NaCl}$   
 $\text{Fe}(\text{OH})_3$  gives a red brown precipitate  
 (e) Pass a moist blue litmus paper through chlorine  
 The litmus paper is bleached

**7.3 Properties And Uses Of Ammonia**

**58**

**[J05/P2/QB9]**

Ammonia is manufactured by the Haber process. Ammonia is used to manufacture nitrogenous fertilisers such as ammonium nitrate.

- (a) The graphs below give information about the percentage of ammonia present in the equilibrium mixture at different temperatures and pressures.

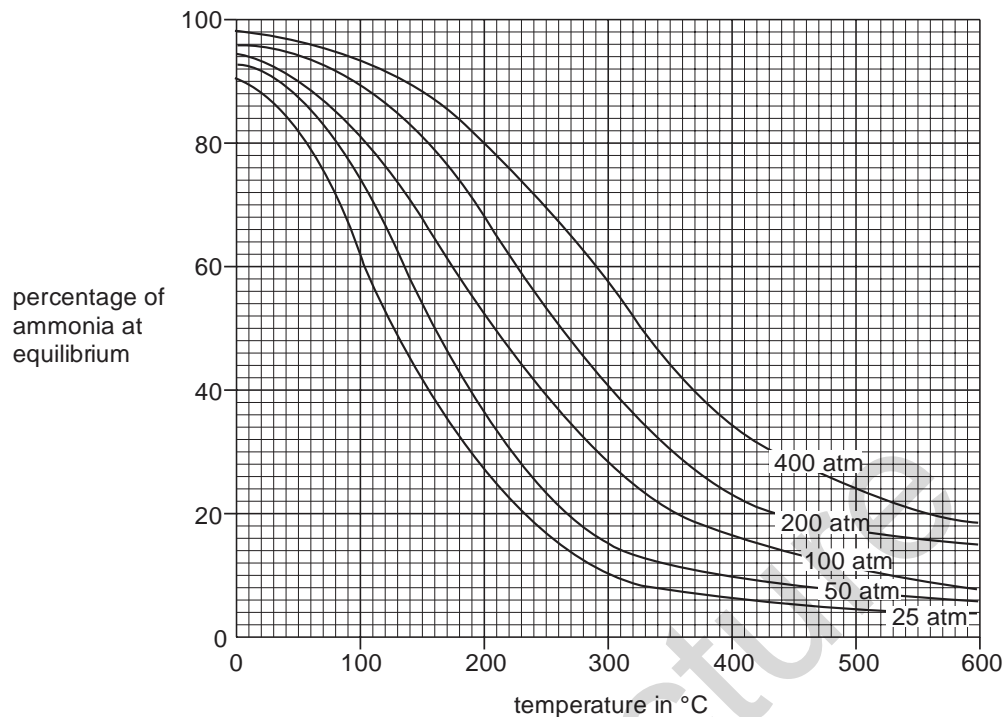

The reaction requires the use of a catalyst, which operates most efficiently within the temperature range 280 – 450 °C.

- (i) Name the catalyst used in the Haber process.
- (ii) Write a balanced equation for the formation of ammonia in the Haber process.
- (iii) Which conditions of temperature and pressure give the highest percentage of ammonia at equilibrium within the catalyst operating temperature range?
- (iv) Suggest why the normal working temperature used in the Haber process is often over 400°C. [5]
- (b) Describe and explain the effect of a catalyst on the rate of a reaction. [3]  
Explain how the use of a catalyst can reduce the overall energy requirement for the Haber process.
- (c) A farmer spreads a fertilizer containing ammonium nitrate onto his land. The farmer then spreads calcium hydroxide on his land to reduce its acidity. [2]  
Write an equation for the reaction between ammonium nitrate and calcium hydroxide.  
Use this equation to explain why the nitrogen content of the fertilizer will be lowered.

### SOLUTION

- (a) (i)  $\text{Fe}_2\text{O}_3$
- (ii)  $\text{N}_2 + 3\text{H}_2 \rightarrow 2\text{NH}_3$ .
- (iii) Temperature: 280 °C  
Pressure: 400 atm
- (iv) High temperature is required to provide activation energy for the reactant molecules.  
(Increasing the temperature increases the kinetic energy of the molecules.  
Collision frequency also increases allowing the reaction to go faster)

- (b) A catalyst increases reaction rate by lowering down the  $E_a$  of the reaction and hence saves energy. In Haber process, the catalyst  $Fe_2O_3$  decreases the  $E_a$  of the reaction. This decrease in  $E_a$  makes large number of molecules available for the chemical reaction
- (c)  $Ca(OH)_2 + 2NH_4NO_3 \rightarrow Ca(NO_3)_2 + 2H_2O + 2NH_3$ .  
Ammonium nitrate produces ammonia gas which is lost into the atmosphere thus decreasing the nitrogen content of the fertilizer.

59

[N06/P2/QB7/c]

- (c) Ammonia is synthesized by the Haber process.  
$$N_2 + 3H_2 \rightleftharpoons 2NH_3$$
- (i) State the sources of both the nitrogen and hydrogen needed for the Haber process. [2]  
(ii) State the essential conditions for the Haber process. [2]

**SOLUTION**

- (c) (i) Nitrogen is obtained from the air while hydrogen comes from methane (cracking of hydrocarbons).  
(ii) Temperature range 350-480 °C  
Pressure of 200 atm  
Iron as a catalyst.

60

[N07/P2/QA1/e]

Choose from the following gases to answer the questions below.

|          |         |                |                  |
|----------|---------|----------------|------------------|
| Ammonia  | butane  | carbon dioxide | carbon monoxide  |
| Hydrogen | methane | nitrogen       | nitrogen dioxide |
| oxygen   |         |                |                  |

Each gas can be used once, more than once or not at all.

Which gas is

- (e) produced by the Haber process, [1]

**SOLUTION**

- (e) Ammonia  
( $N_2 + 3H_2 \rightarrow 2NH_3$ .)

61

[N08/P2/QB7/b]

- (b) The raw materials for the Haber process can be obtained from the air and from hydrocarbons produced by the distillation of petroleum.
- (i) Describe how pure nitrogen can be separated from other gases in the air. [1]  
(ii) Describe how hydrogen can be made from hydrocarbons. [2]

**SOLUTION**

- (b) (i) The air is cooled, compressed, liquefied and fractionally distilled. Nitrogen is collected at -196 C  
(196 C is boiling point on nitrogen)
- (ii) Methane is reacted with steam at a high pressure (35atm) and temperature (800 C) in the presence of nickel as a catalyst. Carbon monoxide and hydrogen are produced as a result which further react with steam to produce more hydrogen  
 $CH_4 + H_2O \rightarrow CO + 3H_2$ .  
 $CO + H_2O \rightarrow CO_2 + H_2$ .



62

[N11/P2/QB6/a,b]

Ammonia is made by the Haber process.

- (a) (i) Write an equation for the formation of ammonia in the Haber process. [1]  
 (ii) State the essential conditions for the Haber process. [3]  
 (b) Ammonia is used to make fertilisers. [1]  
 Explain why farmers use fertilisers. [1]

**SOLUTION**

- (a) (i)  $N_2 + 3H_2 \rightleftharpoons 2NH_3$   
 (ii) 450 °C temperature, 200 atm pressure, iron as a catalyst  
 (b) To increase the crop yield and to make plant grow better

**7.4 Sulfuric Acid**

63

[N06/P2/QB8/a,b(i,ii),c]

The diagram shows the stages in the manufacture of sulphuric acid.

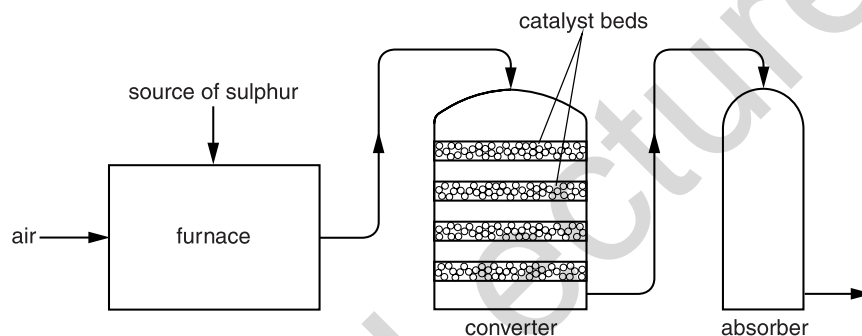

- (a) In the furnace, an ore containing zinc sulphide, ZnS, is heated in oxygen to make zinc oxide, ZnO, and sulphur dioxide. [1]  
 Write an equation for this reaction. [1]  
 (i) An increase in pressure increases the yield of sulphur trioxide. Explain the reason for this effect. [1]  
 (ii) Even though an increase in pressure increases the yield of sulphur trioxide, the reaction in the converter is carried out at atmospheric pressure. [1]  
 Suggest a reason for this. [1]  
 (c) When sulphuric acid is reacted with excess iron powder, iron(II) sulphate and hydrogen are reproduced. [1]  
 Suggest how crystals of iron(II) sulphate could be prepared from this reaction mixture. [2]

**SOLUTION**

- (a)  $2ZnS + 3O_2 \rightarrow 2ZnO + 2SO_2$ .  
 (b) (i) Increase in pressure leads the reaction to the side where there are less number of moles. (There are 2 moles of gas on right hand side while 3 moles of gas left hand side)  
 (ii) It is more economical to carry out the reaction at atmospheric pressure.  
 (Other possible answers: Higher pressure would result in higher concentration of corrosive gases such as SO<sub>2</sub> and SO<sub>3</sub> Increasing pressure will not have much effect on the yield of

SO<sub>3</sub> because there is not much difference in the number of moles on each side of the equation)

- (c) The solution is filtered to remove any unreacted iron powder and then concentrated by partially evaporating the solution. Finally, it is left to crystallise.

64

[N10/P2/QB9]

Sulfur dioxide is a gas which contributes to acid rain.

- (a) (i) State one source of sulfur dioxide in the atmosphere. [1]  
 (ii) Acid rain can cause lakes to become acidic. This may cause fish and plants in the water to die.  
 Describe one **other** environmental problem caused by acid rain. [1]  
 (b) (i) Write an equation, including state symbols, for the reaction of calcium carbonate with sulfuric acid. [2]  
 (b) (ii) State one industrial use of sulfuric acid. [1]  
 (iii) Sulfuric acid is a strong acid.  
 What do you understand by the term *strong acid*? [1]  
 (c) Sulfuric acid is manufactured by the Contact process.  
 Name the raw materials used in the first stage of the Contact process. [1]  
 (d) The equation shows the second stage of the Contact process.  

$$2\text{SO}_2 + \text{O}_2 \rightleftharpoons 2\text{SO}_3 \quad \Delta H = -197 \text{ kJ / mol}$$
  
 (i) State the meaning of the symbol  $\Delta H$ . [1]  
 (ii) Predict and explain the effect of increasing the temperature on the position of equilibrium in this reaction. [2]

**SOLUTION**

- (a) (i) Burning of fossil fuels  
 (ii) Erosion of buildings made **up** of limestone  
 (b) (i)  $\text{CaCO}_3(\text{s}) + \text{H}_2\text{SO}_4(\text{aq}) \rightarrow \text{CaSO}_4(\text{aq}) + \text{CO}_2(\text{g}) + \text{H}_2\text{O}(\text{l})$   
 (b) (ii) It is used in making paints  
 (iii) It completely ionizes in water  
 (c) Air and Sulfur  
 (d) (i) It represents enthalpy change/ change in heat  
 (ii) Increasing **the** temperature favours reverse reaction  
 Reaction is exothermic

65

[J16/P2/QA4/a,b,c]

Sulfuric acid is manufactured by the contact process.

- (a) State the conditions used in the contact process. [2]  
 (b) In the contact process, sulfur dioxide reacts with oxygen.  

$$2\text{SO}_2(\text{g}) + \text{O}_2(\text{g}) \rightleftharpoons 2\text{SO}_3(\text{g})$$
  
 Describe and explain the effect of increasing the concentration of oxygen on the **rate** of this reaction. [2]  
 (c) The catalyst used in the contact process increases the rate of the reaction.  
 Describe one other advantage of using a catalyst in an industrial process. [1]

**SOLUTION**

- (a) 350 – 500 C°

1-10 atm

$V_2O_5$

- (b) Increasing the concentration of oxygen leads to more crowded particles and hence increased frequency of collisions resulting in more product being formed
- (c) By using a catalyst, the reaction can be performed at lower temperature and pressure hence reducing the cost of the process (thus lowering the activation energy of the reaction).

Mega Lecture

## UNIT-8

## THE PERIODIC TABLE

### 8.1 Periodic Trends

**1** [N05/P2/QA1/a,b,c,d]

These diagrams show the electron arrangement in the outer shells of five elements, A to E.  
All elements are from Period 3 of the Periodic Table

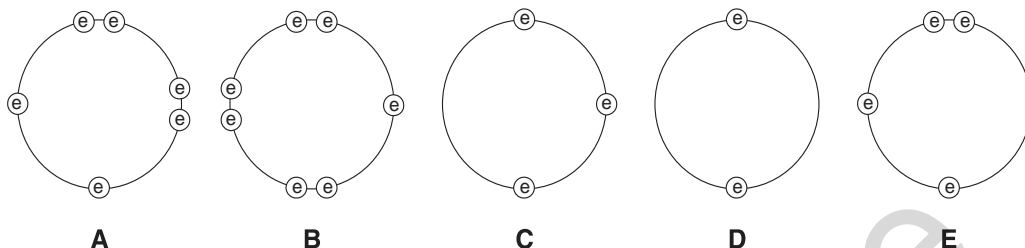

(a) Put the letters A to E in the table to show which elements are metals and which are nonmetals.

|          | Metals | non-metals |
|----------|--------|------------|
| elements |        |            |

- (b) Which element is most likely to be in Group VI? [1]  
 (c) Which element will form an ion of the type  $X^{2+}$ ? [1]  
 (d) Which element has an atomic number of 15? [1]

#### SOLUTION

(a)

|          | metals | non-metals |
|----------|--------|------------|
| elements | C, D   | A, B, E    |

- (b) Element A  
(Number of valence electrons = group number)
- (c) Element D  
(Element D will transfer 2 electrons to a non metal and form an ion with the charge 2+)
- (d) Element E  
(Atomic number 15 lies in group 5)

**2** [J06/P2/QA1/c,d]

Choose from the following elements to answer the questions below.

**Aluminium**    **argon**    **iron**    **nickel**    **Nitrogen**    **phosphorus**    **sodium**

Each element can be used once, more than once or not at all.

Name an element which

- (c) reacts with oxygen to give an acidic oxide, [1]  
 (d) forms an ion that carries a negative charge, [1]

**SOLUTION**

- (c) Nitrogen  
(Non metals usually produce acidic oxides)
- (d) Nitrogen/Phosphorus  
(Non metal ions carry negative charges)

**3** [N06/P2/QA4/d]

- (d) Explain why potassium comes after argon in the Periodic Table even though it has a relative atomic mass which is lower than that of argon. [1]

**SOLUTION**

- (d) Elements in periodic table are arranged in increasing order of atomic number not mass numbers.  
(Atomic number of Ar = 18  
Atomic number of K = 19)

**4** [J07/P2/QB9/a]

This question is about the chemistry of the elements in Period 3 of the Periodic Table.

- (a) Compare the reactions of sodium and of magnesium with cold water. In each case identify the products formed. [3]

**SOLUTION**

- (a) Sodium rapidly reacts with water and many bubbles of hydrogen gas are seen along with sodium hydroxide  
Magnesium reacts very slowly with water and very few bubbles of hydrogen are seen along with magnesium hydroxide.  
[GI elements (sodium) are more reactive than GII element (magnesium)]

**5** [N15/P2/QA1]

Choose from the following elements to answer the questions below.

|           |           |          |        |        |      |
|-----------|-----------|----------|--------|--------|------|
| aluminium | argon     | carbon   | copper | iodine | iron |
| lead      | magnesium | nitrogen | oxygen | sulfur |      |

Each of these elements can be used once, more than once or not at all.  
Which element

- (a) has an ion which, in aqueous solution, reacts with aqueous sodium hydroxide to give a red-brown precipitate, [1]
- (b) has an atom with an electronic configuration with only five occupied electron shells, [1]
- (c) has an oxide which decolourises acidified potassium manganate(VII), [1]
- (d) has a sulfate which is insoluble in water, [1]
- (e) provides an inert atmosphere for the extraction of reactive metals, [1]
- (f) produces ammonia when it is warmed with an aqueous mixture of sodium nitrate and sodium hydroxide? [1]

**SOLUTION**

- (a) Iron ( $Fe^{3+}$  has a red brown precipitate)
- (b) Iodine (Iodine is in 5<sup>th</sup> period; period no. – no. of shells)
- (c) sulfur ( $SO_2$  oxidizes to  $SO_3$  and turns  $KMnO_4$  from purple to colorless)
- (d) lead ( $PbSO_4$  is insoluble)
- (e) argon (noble gases are inert gases and do not react)
- (f) aluminum

**8.2 Group Properties**

**6** [J05/P2/QA3]

This question is about the Periodic Table.

The diagram below shows part of the original Periodic Table first published by Mendeleev in 1869

|         | Period 1 | Period 2 | Period 3 | Period 4 |    | Period 5 |    |
|---------|----------|----------|----------|----------|----|----------|----|
| Group 1 | H        | Li       | Na       | K        | Cu | Rb       | Ag |
| Group 2 |          | Be       | Mg       | Ca       | Zn | Sr       | Cd |
| Group 3 |          | B        | Al       | *        | *  | Y        | In |
| Group 4 |          | C        | Si       | Ti       | *  | Zr       | Sn |
| Group 5 |          | N        | P        | V        | As | Nb       | Sb |
| Group 6 |          | O        | S        | Cr       | Se | Mo       | Te |
| Group 7 |          | F        | Cl       | Mn       | Br | *        | I  |

The asterisks (\*) show gaps in the table that Mendeleev deliberately left.

- (a) Which group of elements in a modern Periodic Table is missing from Mendeleev's Periodic Table? [1]
- (b) Write two **other** differences between Mendeleev's original table and a modern Periodic Table. [2]
- (c) Find rubidium, Rb, in the Periodic Table provided on page 16.  
Predict the reaction between rubidium and cold water.  
Include observations and the chemical equation. [3]

**SOLUTION**

- (a) Group 0  
(Alternative answers: Noble gases group or group 8)
- (b) In the modern periodic table, groups and periods are reversed and relative atomic masses and atomic numbers are shown  
(Alternative answer: Modern periodic table has transition metals and group numbers are mentioned in roman numerals)
- (c) Rb reacts violently with cold water  
**Observations:**  
1. Rb runs/fizzes at the surface of water  
2. It glows and gives off  $H_2$  gas which burns with a pop sound.  
 $2Rb + 2H_2O \rightarrow 2RbOH + H_2$

**7** [J05/P2/QA5/c,e]

- (c) Describe the use of chlorine in the purification of water. [1]
- (e) Name the products, if any, of the reaction of chlorine with

- (i) aqueous potassium fluoride,  
(ii) aqueous sodium bromide. [2]

**SOLUTION**

- (c) Chlorine kills bacteria present in water.  
(e) (i) No reaction  
(ii) Sodium chloride and bromine  
(Chlorine displaces bromine from sodium bromide)

**8 [N05/P2/QB9/a]**

Chlorine, bromine and iodine are elements in Group VII of the Periodic Table.

- (a) Describe how you would carry out a series of experiments to show the trend in reactivity of these three elements, using the reagents shown below.  
aqueous chlorine aqueous potassium chloride  
aqueous bromine aqueous potassium bromide  
aqueous iodine aqueous potassium iodide  
Your answer should include details of
- which of the reagents you would use in each experiment,
  - a table showing the observations you would expect to see,
  - the equations for any reactions.
- [7]

**SOLUTION**

- (a) A more reactive halogen displaces a less reactive halogen from its (aqueous solution) salt solution. So, displacement reactions can be carried out to investigate the trend of reactivity of the halogens. Firstly, add a few drops of chlorine water into a test tube containing 2cm<sup>3</sup> KCl solution. Record any changes observed. Repeat the experiment with KBr and KI solutions. Conduct a second set of experiments with bromine water added to different test tubes containing 2cm<sup>3</sup> of each of the salt solution provided, noting down any observable changes and a third set of experiments conducted with iodine solution added to 2cm<sup>3</sup> of each of the salt solution, recording the changes observed. The results are tabulated below

| Halogen added        | Observation     |  |  |
|----------------------|-----------------|--|--|
|                      | KCl (aq)        | KBr  | KI (aq)  |
| Cl <sub>2</sub> (aq) | -               | Colorless solution turned orange. Br <sub>2</sub> formed | Colorless solution turned reddish brown. I <sub>2</sub> formed |
| Br <sub>2</sub> (aq) | No displacement | -  | Colorless solution   |
| I <sub>2</sub> (aq)  | Reaction        | No displacement  | turned reddish   |

The equations for displacement reactions are:  
Potassium bromide and aqueous chlorine: Cl<sub>2</sub> + 2KBr → 2KCl + Br<sub>2</sub>.  
Potassium iodide and aqueous chlorine: Cl<sub>2</sub> + 2KI → 2KCl + I<sub>2</sub>.  
Potassium iodide and aqueous bromine: Br<sub>2</sub> + 2KI → 2KBr + I<sub>2</sub>.

**9 [J06/P2/QA6/a,b,d]**

Lithium is in Group I of the Periodic Table.  
Lithium reacts with water to form lithium hydroxide and hydrogen.

- (a) Describe what you would observe when a small piece of lithium is dropped onto the surface of cold water. [2]  
 (b) Write the equation for the reaction between lithium and water. [1]  
 (d) Rubidium, Rb, is another element in Group I. [2]  
 Predict what you would observe when a small piece of rubidium is dropped onto cold water.

**SOLUTION**

- (a) Solid lithium float (darts) on the surface of cold water, dissolves and decreases in size. Bubbles can be seen and the container gets hot.  
 (b)  $2\text{Li} + 2\text{H}_2\text{O} \rightarrow 2\text{LiOH} + \text{H}_2$   
 (d) Solid rubidium violently reacts with cold water and explodes in a few seconds resulting in a flame (Reactivity of G1 elements increases down the group and hence Rb reacts much more violently than Li)

**10 [N06/P2/QA4/a,b,e,f]**

Helium, neon, argon, krypton and xenon are noble gases.

- (a) State a use for argon. [1]  
 (b) Use ideas about electronic structure to explain why the noble gases are unreactive. [1]  
 (e) Compounds of xenon with fluorine were first made in the 1960s. [1]  
 Xenon reacts with fluorine at 400 °C to form xenon tetrafluoride, XeF<sub>4</sub>.  
 Write a symbol equation for this reaction.  
 (f) Balloons filled with helium, neon, argon and krypton were tied to a bar. They were held horizontally at the same height and then released. The position of three of the balloons 5 seconds after release is shown in the diagram.

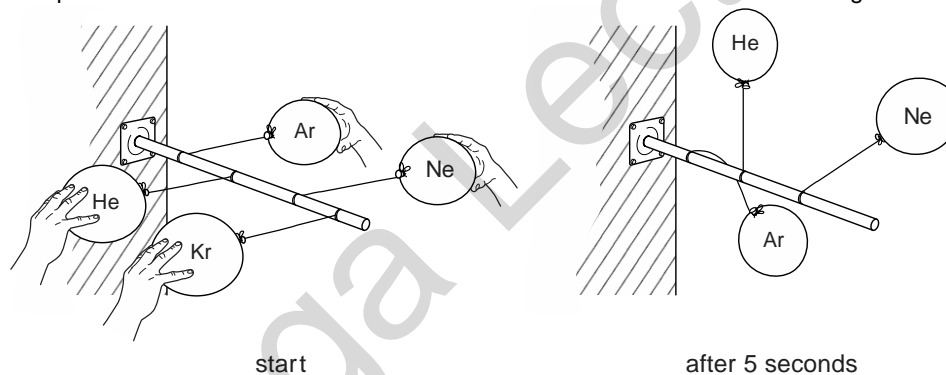

Predict the position of the balloon filled with krypton. [1]

**SOLUTION**

- (a) Light bulbs (Other possible uses: fluorescent tubes, lasers, for providing inert atmosphere, welding, refining of titanium or zirconium)  
 (b) Noble gases have complete valence shell electrons.  
 (e)  $\text{Xe} + 2\text{F}_2 \rightarrow \text{XeF}_4$   
 (f) Balloon filled with Kr will be below the balloon filled with Ar (Kr has higher relative atomic mass than Ar).



**11** [J07/P2/QA1/d]

Choose from the following oxides to answer the questions below.

**aluminium oxide**      **calcium oxide**      **carbon monoxide**      **copper(II)**  
**oxidesulphur dioxide**      **sulphur trioxide**      **vanadium(V) oxide**

Each oxide can be used once, more than once or not at all.

Name an oxide which

(d) reacts with water to give sulphurous acid, [1]

**SOLUTION**

(d) Sulphur dioxide  
( $\text{SO}_2 + \text{H}_2\text{O} \rightarrow \text{H}_2\text{SO}_3$ )

**12** [J07/P2/QA6]

Chlorine is in Group VII of the Periodic Table.

Chlorine reacts with aqueous potassium iodide to form potassium chloride and iodine.

(a) Describe what you would see when chlorine is added to aqueous potassium iodide. [1]

(b) Write the equation for the reaction between chlorine and potassium iodide. [1]

(c) When chlorine reacts with potassium iodide, iodine molecules are formed.

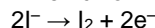

Explain why the formation of an iodine molecule from iodide ions is an example of oxidation. [1]

(d) Astatine is another element in Group VII. It is highly radioactive and so is very difficult to study.

(i) Predict, with reasons, whether astatine will react with aqueous potassium iodide. [1]

(ii) Write the equation for the reaction between astatine and sodium. [1]

**SOLUTION**

(a) Solution turns from colorless to brown  
(Iodide ion oxidises to iodine which is brown in color)

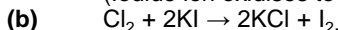

(c) Electrons are lost as iodine is formed from iodide ions  
(Oxidation is loss of electrons)

(d) (i) Since astatine lies below iodine in group VII, it is less reactive and, hence, does not react with potassium iodide  
(Astatine is poorer oxidising agent than iodine)

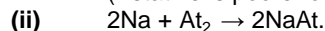

**13** [J07/P2/QB9/e]

(e) Chlorine(VII) oxide,  $\text{Cl}_2\text{O}_7$ , has a simple molecular structure.  
Suggest one **physical** and one **chemical** property of  $\text{Cl}_2\text{O}_7$ . [2]

**SOLUTION**

(e) Physical property: Low melting point  
Chemical property: Reacts with water to give an acidic solution.  
(Other possible physical properties: Low boiling point/poor conductor of heat and electricity.  
Other possible chemical property: Reacts with alkali to produce a salt)

**14** [N07/P2/QA3/a]

Germanium, Ge, is an element in Group IV of the Periodic Table. Some of its chemistry resembles that of carbon.

- (a) How many electrons does an atom of germanium have in its outer shell? [1]

**SOLUTION**

- (a) 4  
(Group number = number of valence electrons)

**15** [J08/P2/QA1/c]

Choose from the following gases to answer the questions below.

**Ammonia**                      **argon**                      **carbon monoxide**                      **chlorine**  
**Hydrogen**                      **nitrogen**                      **nitrogen dioxide**                      **oxygen**

Each gas can be used once, more than once or not at all.

Name a gas which

- (c) is monatomic, [1]

**SOLUTION**

- (c) Argon  
(Argon is an inert gas, stable in its monatomic state)

**16** [J08/P2/QA5/a,c]

One of the largest uses of phosphorus is in the making of safety matches. A safety match ignites when it is rubbed against the striking surface of a match box.

The match head contains the following substances.

- phosphorus, P<sub>4</sub>
- potassium chlorate(V), KClO<sub>3</sub>
- sulphur, S
- a hydrocarbon wax

- (a) The friction between the match head and the striking surface generates enough heat for the phosphorus to burn.  
Phosphorus burns to form phosphorus(V) oxide. This oxide is covalently bonded with a molecular structure.
- (i) What is the molecular formula of phosphorus(V) oxide? [1]
- (ii) Suggest **one** physical and **one** chemical property of phosphorus(V) oxide. Physical property chemical property [2]
- (c) The sulphur on the match head ignites.  
Write an equation to show the combustion of sulphur. [1]

**SOLUTION**

- (a) (i) P<sub>2</sub>O<sub>5</sub> / P<sub>4</sub>O<sub>10</sub>
- (ii) **Physical property:** Low melting and boiling point  
**Chemical property:** Dissolves in water to form an acid  
(P<sub>2</sub>O<sub>5</sub> is a covalent compound and a non metallic oxide)
- (c) S + O<sub>2</sub> → SO<sub>2</sub>.

17

[N08/P2/QA1/(i,ii,iii,iv,v)]

The diagram shows part of the Periodic Table.

|  |    |    |    |    |    |    |    |    |    |    |    |
|--|----|----|----|----|----|----|----|----|----|----|----|
|  |    |    |    |    |    |    |    |    |    | He |    |
|  |    |    |    |    |    | B  | C  | N  | O  | F  | Ne |
|  |    |    |    |    |    | A/ | Si | P  | S  | Cl | Ar |
|  | Fe | Co | Ni | Cu | Zn | Ga | Ge | As | Se | Br | Kr |
|  |    |    |    |    |    |    |    |    |    | I  | Xe |

Answer these questions using **only** the elements shown in the diagram.

Each element can be used once, more than once or not at all.

Write the symbol for

- (i) an element which is in Group 5 and Period 3, [1]  
 (ii) an element which is used as a gas in balloons, [1]  
 (iii) an element which forms ions in aqueous solution which give a white precipitate on reaction with aqueous silver nitrate, [1]  
 (iv) an element which forms an ion of type  $X^{3-}$ , [1]  
 (v) an element which is a catalyst for the hydrogenation of alkenes, [1]

**SOLUTION**

- (i) P  
(From periodic table)  
 (ii) He  
(Being the lightest gas, He is used in balloons)  
 (iii) Cl  
(Chlorine gives chloride ions in water which gives a white precipitate of AgCl with silver nitrate)  
 (iv) N/P/As  
(The elements in group 5 can form ions with -3 charge)  
 (v) Ni

18

[N08/P2/QA6/a(i)]

Electrolysis is used to produce many important chemicals such as chlorine, sodium hydroxide and aluminium.

- (a) (i) Why is chlorine used in water treatment? [1]

**SOLUTION**

- (a) (i) Chlorine is used to kill bacteria present in the water.  
(Other possible answers: To kill micro-organisms/germs, to disinfect/sterilize the water)

19

[N09/P2/QA3/c]

- (c) Argon is used in the manufacture of titanium. In this process titanium(IV) chloride,  $TiCl_4$ , is reduced with hot sodium. The products are titanium and sodium chloride.

- (i) Write an equation for the reaction between titanium(IV) chloride and sodium. [1]  
 (ii) During this reaction argon is blown over the mixture of sodium and titanium(IV)chloride. Suggest why the reaction is carried out in an atmosphere of argon. [1]

**SOLUTION**

- (c) (i)  $\text{TiCl}_4 + 4\text{Na} \rightarrow \text{Ti} + 4\text{NaCl}$ .  
 (ii) To provide an inert atmosphere so that sodium does not react with oxygen  
 (iii)  $\text{TiCl}_4 + 2\text{H}_2\text{O} \rightarrow \text{TiO}_2 + 4\text{HCl}$ .

**20** [N09/P2/QA5/c]

- (c) Bromine is a halogen.  
 Complete the table to estimate both the density and boiling point of bromine.

| halogen  | density of solid halogen in g/cm <sup>3</sup> | boiling point / °C |
|----------|---|--------------------|
| fluorine | 1.51  | -188               |
| chlorine | 1.56  | -35                |
| bromine  |   |                    |
| iodine   | 4.93  | 184                |

[2]

**SOLUTION**

(c)

| Halogen  | density of solid halogen in g/cm <sup>3</sup> | boiling point/ °C |
|----------|---|-------------------|
| Fluorine | 1.51  | -188              |
| Chlorine | 1.56  | -35               |
| Bromine  | <b>3.12</b>                                   | <b>59</b>         |
| Iodine   | 4.93  | 184               |

(Range for density: 2-4)

(Range for boiling point: 20-120)

**21** [N09/P2/QB7/c]

- (c) Copper is a transition element.  
 (i) Name **two** transition elements, or compounds of transition elements, which are used as catalysts. For each catalyst name an industrial product made using the catalyst. [2]  
 (ii) Other than acting as catalysts state **two** properties which are specific to transition elements. [2]

**SOLUTION**

- (c) (i) 1. Iron is used as a catalyst for the production of ammonia (Haber process)  
 2. Nickel is used as a catalyst for making margarine (Hydrogenation of alkenes)  
 (Other possible answer: Vanadium (V) oxide for making sulfur trioxide (Contact process))  
 (ii) 1. They have variable oxidation state  
 2. They form coloured compounds  
 (Other possible answers: They have high density, high melting and boiling points)

**22** [J10/P2/QA2/c,d]

- (c) Predict two **physical** properties of francium. [2]  
 (d) A scientist predicts that francium reacts violently with water.  
 Write the equation for this reaction. [1]

**SOLUTION**

- (c) 1. Electrical conductor  
 2. Shiny surface (lustrous)  
 (d) Any property of typical metals can be written such as; thermal conductor, low melting point, soft, low density, malleable, ductile.  
 $2\text{Fr} + 2\text{H}_2\text{O} \rightarrow 2\text{FrOH} + \text{H}_2$

**23** [N10/P2/QA1/a(i,v)]

- (a) Choose from the following list of metals to answer the questions below.  
**Aluminium**                      **iron**                      **lead**                      **magnesium**  
**Potassium**                      **silver**                      **vanadium**  
 Each metal can be used once, more than once or not at all.  
 Which metal  
 (i) reacts with cold water to form an alkaline solution, [1]  
 (v) is in Period 5 of the Periodic Table? [1]

**SOLUTION**

- (a) (i) Potassium  
*Group I metals react with cold water to form alkaline solutions*  
 (v) Silver  
*Silver is found in the 5<sup>th</sup> period of the periodic table*

**24** [N10/P2/QA4/a,b,c(i,iii)]

- Chlorine, bromine and iodine are non-metals in Group VII of the Periodic Table. Their molecules are diatomic.  
 (a) What do you understand by the term *diatomic*? [1]  
 (b) (i) Describe the trend in colour of the Group VII elements down the Group. [1]  
 (ii) In what physical state do the following elements exist at room temperature and pressure?  
 bromine iodine [2]  
 (c) Aqueous bromine reacts with aqueous potassium iodide.  
 $\text{Br}_2(\text{aq}) + 2\text{KI}(\text{aq}) \rightarrow 2\text{KBr}(\text{aq}) + \text{I}_2(\text{aq})$   
 (i) Write an ionic equation for this reaction. [1]  
 (iii) Explain why aqueous bromine does not react with aqueous potassium chloride. [1]

**SOLUTION**

- (a) A molecule containing two atoms.  
 (b) (i) The color gets darker down the group; from yellow of Fluorine to black of Iodine  
 (ii) Bromine: Liquid  
 Iodine: Solid  
 (c) (i)  $\text{Br}_2 + 2\text{I}^- \rightarrow 2\text{Br}^- + \text{I}_2$   
 (iii) Bromine is less reactive than chlorine and hence is unable to replace chlorine from potassium chloride

25

[J11/P2/QA4/a,c,d(i)]

Fluorine, chlorine, bromine and iodine are elements in Group VII of the Periodic Table. Scientists are trying to synthesise a new element in Group VII with a proton number of 117.

- (a) How many valency electrons will be present in one atom of this new element? [1]  
 (c) Predict **two** physical properties of this new element. [2]  
 (d) Fluorine reacts with magnesium to form magnesium fluoride.  
 (i) Write a balanced equation for this reaction. [1]

**SOLUTION**

- (a) Seven  
 Number of **valence electrons = group number**  
 (c) 1. Poor electrical conductor  
 2. Relatively low melting point  
 Other properties can include; **poor** heat conductor, **solid**, **low** boiling point, **black** in color, **insoluble** in water and **radioactive**  
 (d) (i)  $\text{Mg} + \text{F}_2 \rightarrow \text{MgF}_2$

26

[N11/P2/QA1/c,d]

Choose from the following list of elements to answer the questions below.

**Calcium**            **chlorine**            **hydrogen**            **iodine**            **nickel**  
**Sodium**            **vanadium**            **zinc**

Each element can be used once, more than once, or not at all.

Which element

- (c) oxidises aqueous bromide ions to bromine, [1]  
 (d) is used in water purification to kill bacteria, [1]

**SOLUTION**

- (c) Chlorine  
*Chlorine being **more reactive** than bromine, can **oxidize** bromide ions to bromine*  
 (d) Chlorine  
*Chlorine reacts with water to give a mixture of HCl and **HClO**. HClO is a powerful **oxidizing agent**, and kills bacteria by **oxidation***

27

[N11/P2/QA5/d(i)]

- (d) Bromine forms a variety of compounds with other halogens.  
 (i) Bromine reacts with fluorine to form bromine(I) fluoride, BrF.  
 Write an equation for this reaction. [1]

**SOLUTION**

- (d) (i)  $\text{Br}_2 + \text{F}_2 \rightarrow 2\text{BrF}$

28

[N12/P2/QB6/a(iii),b]

Seawater contains chloride, bromide and iodide ions.

Bromine can be manufactured by bubbling chlorine through seawater.

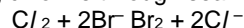

- (a) (iii) Explain why iodine will not displace bromine from seawater. [1]

- (b) Bromine reacts with many elements to form bromides.  
The table shows the boiling points and electrical conductivity for the bromides A, B, C and D.

| bromide | boiling point / °C | electrical conductivity when molten |
|---------|--------------------|-------------------------------------|
| A       | 1435               | Conducts                            |
| B       | 916                | Conducts                            |
| C       | 154                | does not conduct                    |
| D       | 173                | does not conduct                    |

Which two bromides are bonded covalently? Give a reason for your answer. [1]

**SOLUTION**

- (a) (iii) Iodine is less reactive than bromine  
(b) C and D because they have low boiling points and do not conduct in molten states

**29 [N12/P2/QB9/a(i)]**

Barium is a reactive metal in Group II of the Periodic Table.  
Barium reacts with water in a similar way to sodium. The products of the reaction are aqueous barium hydroxide and a colourless gas.

- (a) (i) Chlorine can be used to bleach wood pulp.  
Name another chemical that can be used to bleach wood pulp. [1]

**SOLUTION**

- (a) (i) Sulfur dioxide OR Hydrogen peroxide

**30 [J13/P2/QA1/a,c,e,f]**

Choose from the following elements to answer the questions below.

**Barium**      **calcium**      **carbon**      **copper**      **helium**  
**Hydrogen**   **iron**      **lead**      **lithium**      **sulfur**      **zinc**

Each element can be used once, more than once or not at all.

Name an element which

- (a) forms two acidic oxides, [1]  
(c) has an atom with an electronic configuration with only four occupied shells, [1]  
(e) has an ion which, in aqueous solution, is used to test for sulfate ions, [1]  
(f) reacts with water to form an alkaline solution. [1]

**SOLUTION**

- (a) Sulfur  
(Sulfur forms SO<sub>3</sub> and SO<sub>2</sub>, both of which are acidic oxides)  
(c) Calcium/iron  
(Calcium (2,8,8,2); Iron (2,8,8,8))  
(e) Barium  
(f) Lithium/calcium/barium  
(Lithium, calcium and barium react with water to form basic oxides)

**31 [J13/P2/QA3/a]**

Aluminium is a metal and both iodine and bromine are non-metals.

- (a) How does the number of valency electrons help to explain why aluminium is a metal and iodine and bromine are non-metals? [2]

**SOLUTION**

- (a) Aluminium has 3 valence electrons; it loses these 3 electrons readily and, hence, is a metal. Both iodine and bromine have 7 valence electrons and they gain an electron, hence, they are non metals (Metals lose electrons and become positive ions while non metals gain electrons to become negative ions)

**32 [J13/P2/QA5/b]**

- (b) Suggest one property of aqueous X caused by the presence of vanadium. [1]

**SOLUTION**

- (b) The solution is colored

**33 [N13/P2/QA1/c,e,f]**

Choose from the following elements to answer the questions below.

|                 |                 |                 |                  |
|-----------------|-----------------|-----------------|------------------|
| <b>Chlorine</b> | <b>hydrogen</b> | <b>iron</b>     | <b>lithium</b>   |
| <b>Nickel</b>   | <b>nitrogen</b> | <b>oxygen</b>   | <b>potassium</b> |
| <b>Silver</b>   | <b>sulfur</b>   | <b>vanadium</b> | <b>zinc</b>      |

Each element can be used once, more than once or not at all.

Which element

- (c) is a non-metallic solid, an atom of which contains only six valency electrons, [1]  
 (e) is in Period 5 of the Periodic Table, [1]  
 (f) forms a white oxide which is amphoteric? [1]

**SOLUTION**

- (c) Sulfur  
(Electronic configuration of Sulfur is 2,8,6)  
 (e) Silver  
 (f) Zinc  
(Oxides of Zinc, Aluminium and Lead (ZAL) are amphoteric)

**34 [N13/P2/QA3/c,d(i)]**

- (c) Silicon reacts with chlorine on heating to form silicon(IV) chloride, SiCl<sub>4</sub>.  
 Construct an equation for this reaction. [1]  
 (d) (i) Suggest **two** physical properties of silicon(IV) chloride other than solubility. [2]

**SOLUTION**

- (c)  $\text{Si} + 2\text{Cl}_2 \rightarrow \text{SiCl}_4$   
 (d) (i) 1. It does not conduct heat or electricity  
 2. It is a liquid  
 (Other possible answer: it has a low melting and boiling point)

**35 [J14/P2/QB10/c(ii),d(ii)]**

- (c) (ii) Predict **two** physical properties of magnesium astatide. [2]  
 (d) (ii) Explain why astatine does not react with aqueous magnesium iodide. [1]





- (a) (i) Describe the general trend in the density of the Group I metals. [1]  
 (ii) Predict the boiling point of potassium. [1]  
 (iii) What is the physical state of caesium at 35 °C? Explain your answer. [1]  
 (b) (i) Describe the trend in reactivity of the Group I metals with water. [1]  
 (ii) Construct the equation for the reaction of rubidium with water. [1]  
 (d) (ii) State one industrial use of nickel as a catalyst. [1]

**SOLUTION**

- (a) (i) Density generally increases down the group.  
*(K is an exception)*  
 (ii) 760°C  
*(Acceptable range 720-800°C)*  
 (iii) Caesium is liquid at 35°C because melting point is below 35°C and boiling point is above 35°C.  
 (b) (i) Reactivity with water increases down the group.  
 (ii)  $2\text{Rb} + 2\text{H}_2\text{O} \rightarrow 2\text{RbOH} + \text{H}_2$ .  
 (d) (ii) Manufacture of margarine.

**38**

**[J15/P2/QA2/a]**

Hydrogen reacts with halogens to form hydrogen halides.

- (a) Predict which halogen reacts most violently with hydrogen. [1]

**SOLUTION**

- (a) Fluorine (*small size, short bond length, highly electronegative, highly reactive*)

**39**

**[N15/P2/QB8/b,c]**

- (b) Chlorine displaces bromine from an aqueous solution of potassium bromide.  
 (i) Construct the equation for this reaction. [2]  
 (ii) Explain why bromine does not react with aqueous potassium chloride. [1]  
 (iii) Give the charge of a chloride ion and its electronic configuration.  
 Charge [2]  
 electronic configuration [2]  
 (c) Explain why sodium chloride does not conduct electricity when solid but does conduct electricity when molten. [2]

**SOLUTION**

- (b) (i)  $\text{Cl}_2 + 2\text{KBr} \rightarrow \text{Br}_2 + 2\text{KCl}$ . (*Cl<sub>2</sub> is more reactive and hence is able to replace Br<sup>-</sup> from KBr*)  
 (ii) Bromine is less reactive than chlorine  
 (iii) Charge: -1  
 Electronic configuration: 2,8,8  
 (c) In solid NaCl, ions are fixed in position and are not free to move about. However, in molten NaCl, ions break from the lattice and are free to move about

**8.3 Transition Elements**

**40**

**[J05/P2/QA2/d]**

- (d) Write **two** typical properties that are generally common **only** to transition elements. [2]

**SOLUTION**

- (d) 1. They form colored compounds.  
2. They have variable oxidation states  
(Alternative answers: they can act as catalysts/they can form complex ions)

**41** [J06/P2/QA1/a]

Choose from the following elements to answer the questions below.

Aluminium      argon      iron      nickel      Nitrogen      phosphorus  
sodium

Each element can be used once, more than once or not at all.

Name an element which

- (a) is used as a catalyst in the hydrogenation of alkenes, [1]

**SOLUTION**

- (a) Nickel  
(Nickel or Platinum is used as a catalyst to convert alkenes to alkanes)

**42** [J07/P2/QA1/a]

Choose from the following oxides to answer the questions below.

aluminium oxide      calcium oxide      carbon monoxide      copper(II) oxide  
sulphur dioxide      sulphur trioxide      vanadium(V) oxide

Each oxide can be used once, more than once or not at all.

Name an oxide which

- (a) is used as a catalyst in the Contact process, [1]

**SOLUTION**

- (a) Vanadium (V) oxide  
( $V_2O_5$  is used to oxidise  $SO_2$  to  $SO_3$  in contact process)

**43** [N07/P2/QA4/e]

In recent years scientists have made tube-shaped structures of carbon called nanotubes.

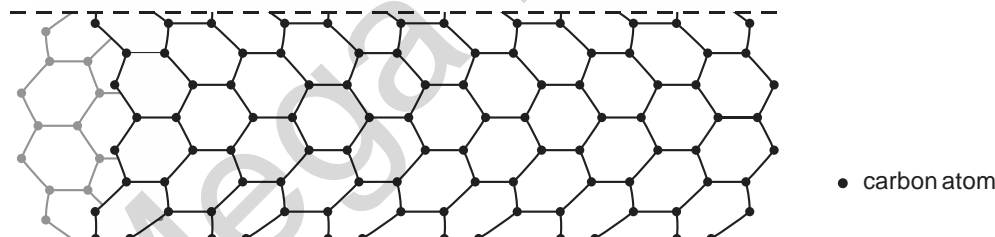

- (e) Recently, chemists have been trying to attach atoms of transition elements to buckminsterfullerene to make more efficient catalysts.  
State **two** properties, other than catalysis, which distinguish transition elements from other metals.[2]

**SOLUTION**

- (e) Transition elements have variable valencies and they produce colored compounds.  
(Other possible properties: Have high melting points and densities, form complex ions)

44

[J08/P2/QA1/e]

Choose from the following gases to answer the questions below.

**Ammonia**      **argon**      **carbon monoxide**      **chlorine**  
**Hydrogen**      **nitrogen**      **nitrogen dioxide**      **oxygen**

Each gas can be used once, more than once or not at all.

Name a gas which

(e) is used in the Contact process. [1]

**SOLUTION**

(e) Oxygen  
(SO<sub>2</sub> is oxidised to SO<sub>3</sub> by reacting with oxygen)

45

[J08/P2/QA3/d]

A student found a copy of a Periodic Table published in the year 1930. Several elements were missing from this table because they had not yet been discovered. One of these elements was technetium, Tc.

One isotope of technetium has the symbol  ${}_{43}^{98}\text{Tc}$ .

(d) From its position in the modern Periodic Table predict two properties of technetium. [2]

**SOLUTION**

(d) 1. It has a high melting and boiling point  
2. It shows variable oxidation state  
(Other possible properties: forms colored compounds, has high density, behaves as a catalyst and its compounds form complex ions)

46

[N08/P2/QB10/d]

(d) In cancer treatment, the radioactive iodine can be injected into the tumour with a titanium needle.

(i) Titanium is a transition element. State **three** characteristic properties of transition elements. [2]

(ii) An oxide of titanium is formed from Ti<sup>3+</sup> ions and oxide ions.  
Deduce the formula of this compound. [1]

(iii) Titanium(IV) chloride, TiCl<sub>4</sub>, reacts with water to form titanium(IV) oxide, TiO<sub>2</sub>, and hydrogen chloride. Write an equation for this reaction. [1]

**SOLUTION**

(d) (i) 1. High melting and boiling points  
2. Variable valencies  
3. Give colored compounds  
4. High densities  
(ii) Ti<sub>2</sub>O<sub>3</sub>  
(iii) TiCl<sub>4</sub> + 2H<sub>2</sub>O → TiO<sub>2</sub> + 4HCl.

47

[J09/P2/QA1/a]

Choose from the following substances to answer the questions below.

**copper(II) chloride**      **chlorine**      **ethanoic acid**      **hydrochloric acid**  
**manganese(IV) oxide**      **platinum**      **potassium dichromate(VI)**      **sodium chloride**  
**sulfuric acid**      **vanadium(V) oxide**

Each substance can be used once, more than once or not at all.

Name a substance which

(a) is a catalyst in the Contact process, [1]

**SOLUTION**

- (a) Vanadium (V) oxide (Contact process is used to make  $\text{H}_2\text{SO}_4$ .  $\text{V}_2\text{O}_5$  is used as a catalyst in this process)

**48** [N10/P2/QA1/a(iii)]

- (a) Choose from the following list of metals to answer the questions below.

Aluminium                  iron                  lead                  magnesium  
Potassium                  silver                  vanadium

Each metal can be used once, more than once or not at all.

Which metal

- (iii) is the catalyst used in the industrial manufacture of ammonia, [1]

**SOLUTION**

- (a) (iii) Iron  
*Iron is used as a catalyst in the Haber's process.*

**49** [N11/P2/QA1/b]

Choose from the following list of elements to answer the questions below.

Calcium                  chlorine                  hydrogen                  iodine                  nickel  
Sodium                  vanadium                  zinc

Each element can be used once, more than once, or not at all.

Which element

- (b) is a catalyst in the hydrogenation of alkenes [1]

**SOLUTION**

- (b) Nickel  
*Hydrogenation of alkenes is carried out in the presence of nickel/platinum as a catalyst at about 150 °C*

**50** [N13/P2/QA1/b]

Choose from the following elements to answer the questions below.

Chlorine                  hydrogen                  iron                  lithium                  Nickel                  nitrogen  
oxygen                  potassium                  Silver                  sulfur                  vanadium                  zinc

Each element can be used once, more than once or not at all.

Which element

- (b) is used as a catalyst in the manufacture of margarine, [1]

**SOLUTION**

- (b) Nickel  
(Margarine is made by hydrogenation of alkenes which is done under the presence of Ni as a catalyst)

**51** [J16/P2/QA5/e]

- (e) The symbol for one isotope of cobalt is  ${}^{57}_{27}\text{Co}$ .  
Another isotope of cobalt has a nucleon number of 59.  
Write its symbol.

[1]

**SOLUTION**

- (e)  ${}^{59}\text{Co}_{27}$

## UNIT-9

## METALS

### 9.1 PROPERTIES OF METALS

#### 1 [J05/P2/QA2/a,b]

Iron is one of the most important metals. It is a transition element.

Most iron is used in the alloy steel.

- (a) Explain, in terms of metallic bonding, why iron is a good electrical conductor. [2]  
(b) Describe how different proportions of carbon can modify the physical properties of steel. [2]

#### SOLUTION

- (a) Metallic structure of iron has positive ions surrounded by sea of delocalized electrons. These electrons move from high potential to low potential and help in conducting electricity.  
(b) High carbon steels are harder and brittle while low carbon steels are soft and malleable.  
(Carbon atoms disrupts the movement of iron atoms and make the steel harder)

#### 2 [N05/P2/QB11/c]

- (c) (i) Both copper and aluminium are good conductors of electricity. Explain why overhead cables are usually made from aluminium and not copper.  
(ii) Draw a diagram to show the structure and bonding of aluminium metal. Use your diagram to explain why aluminium conducts electricity so well.

#### SOLUTION

- (c) (i) Aluminium is a lighter metal as compared to copper and is more resistant to corrosion  
(ii) Aluminium consists of a closed packed structure of positive Al ions in a sea of delocalized electrons. The delocalized electrons are responsible for the conduction of electricity. Conductivity increases with more electrons available. Compared to metals that have 1 or 2 valence electrons respectively, Al has more delocalized electrons and conducts electricity at a faster rate.

free electrons from outer shells of metal atoms

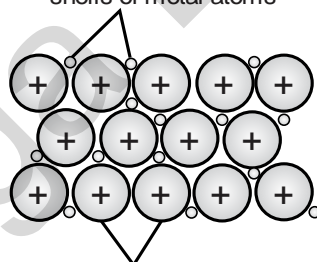

#### 3 [J06/P2/QB10/a]

Brass is an alloy containing zinc and copper.

- (a) Explain why the physical properties of brass are different from those of zinc and copper. [1]

#### SOLUTION

- (a) The atoms in brass do not slide as easily as those in zinc and copper  
(Brass has unevenly and irregularly arranged atoms as compared to evenly and regularly)

arranged atoms in zinc and copper and hence layers in brass offer resistance in sliding over one another)

**4** [N06/P2/QA2/a]

The table shows the decomposition temperatures of some metal carbonates.

| metal carbonate     | decomposition temperature / °C |
|---------------------|--------------------------------|
| magnesium carbonate | 540                            |
| calcium carbonate   | 900                            |
| strontium carbonate | 1280                           |
| barium carbonate    | 1360                           |

- (a) (i) Describe how the decomposition temperature depends on the position of the metal in the reactivity series. [1]  
(ii) Write an equation for the thermal decomposition of magnesium carbonate. [1]

**SOLUTION**

- (a) (i) The higher the position of the metal in the reactivity series, the higher the decomposition temperature of the metal carbonate.  
(ii)  $MgCO_3 \rightarrow MgO + CO_2$ .

**5** [N06/P2/QB10/d]

- (d) Bronze is an alloy of copper and tin. Bronze is less malleable than pure copper. Use ideas about the structure of metals and alloys to explain why bronze is less malleable than pure copper. [2]

**SOLUTION**

- (d) In copper, metal atoms are arranged in layers which can slide over each other. In bronze (an alloy), atoms of two different sizes are arranged in layers and hence layers can not slide over each other.

**NOTE: u may add a diagram for more understanding of concept of alloys.**

**6** [J08/P2/QB10/a,b]

Brass is an alloy of zinc and copper.

- (a) Describe, with the aid of a labelled diagram, the structure of a metal such as copper. [2]  
(b) Explain, in terms of their structures, why both zinc and copper are good conductors of electricity. [1]

**SOLUTION**

- (a)

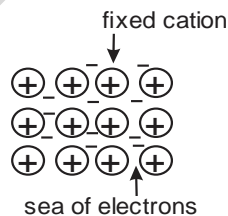

In metals, positive ions are arranged in layers surrounded by a sea of mobile electrons

- (b) Electrons are delocalized in the metallic structure of zinc and copper. When a potential difference is applied, electrons move from higher potential to lower potential making these metals good conductors of electricity

**7** [N08/P2/QA5/a(i)]

Cement is made by heating clay with crushed calcium carbonate. During this process, the calcium carbonate is first converted to calcium oxide.

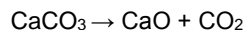

- (a) (i) What name is given to this type of chemical reaction? [1]

**SOLUTION**

- (a) (i) Thermal decomposition

**8** [N10/P2/QA1/b]

- (b) Draw a labelled diagram to show the structure of a typical metal. [2]

**SOLUTION**

- (b)

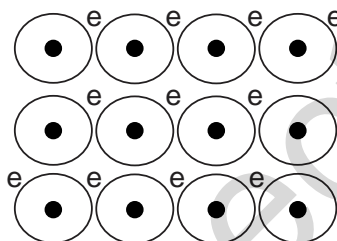

Positive ions are surrounded by sea of delocalized electrons in a typical metal

**9** [N11/P2/QB9/b]

- (b) Explain why barium metal conducts electricity. [1]

**SOLUTION**

- (b) Due to the presence of free valence electrons  
(Metals have **free electrons** present which help them **conduct** electricity)

**10** [N12/P2/QA5/d]

- (d) Nickel is a metal.  
State three physical properties shown by **all** metals. [3]

**SOLUTION**

- (d) 1. Conductors of heat and electricity  
2. Malleable and ductile  
3. Shiny appearance



**11** [J14/P2/QA5/b,c]

- (b) Iron has a high melting point because it has strong metallic bonding. Describe, using a labelled diagram, metallic bonding. [2]
- (c) When iron is made into the alloy steel, the properties of iron are changed. High carbon steels are stronger than iron but are brittle. State a property of low carbon steels. [1]

**SOLUTION**

(b)

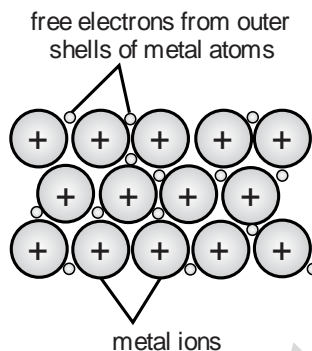

- (c) The metallic bond is the force of attraction between mobile valence electrons and iron ions.  
Low carbon steels are softer  
(Other properties: More malleable/More ductile)

**12** [N14/P2/QA2/d(i,iii)]

- (d) (i) Describe two **other** differences in the physical properties of sodium and nickel. [2]  
(iii) Explain why an alloy of nickel and copper is less malleable than copper alone. [2]

**SOLUTION**

- (d) (i) 1. Sodium has low density while Nickel has high density.  
2. Sodium has low melting point and boiling point while Nickel has high melting point and boiling point.  
(iii) Nickel ions and Copper ions are of different sizes causing disruption in the layers of metallic alloy and hence the layers do not slide over each other easily.

**13** [J15/P2/QB7]

Titanium can be manufactured by heating titanium(IV) chloride,  $TiCl_4$ , with magnesium.

- (a) Construct the equation for this reaction. [1]  
(b) Explain why this reaction involves both oxidation **and** reduction. [2]  
(c) What mass of titanium can be made from 125 g of titanium(IV) chloride? [3]  
(d) Which metal is the less reactive, magnesium or titanium? Explain your answer. [1]  
(e) Titanium(IV) chloride is a liquid with a low boiling point of 126 °C. Suggest the structure and bonding of titanium(IV) chloride. [2]  
(f) Explain how titanium metal conducts electricity. [1]

**SOLUTION**

- (a)  $\text{TiCl}_4 + 2\text{Mg} \rightarrow 2\text{MgCl}_2 + \text{Ti}$ .
- (b) Ti reduces as its oxidation number decreases from +4 in  $\text{TiCl}_4$  to 0 in Ti. Mg oxidizes as its oxidation number increases from 0 in Mg to +2 in  $\text{MgCl}_2$ .
- (c) Moles of  $\text{TiCl}_4 = \text{mass}/\text{Mr} = 125 / 190 = 1.4 \text{ mol}$   
Moles of  $\text{TiCl}_4$  is 0.658% of Ti = 25.3  
mass of Ti = 31.6 g
- (d) Titanium is less reactive because magnesium replaces it during the reaction
- (e)  $\text{TiCl}_4$  is simple covalent molecule
- (f) All metals have delocalized electrons which help in conduction of electricity

**14**

**[N15/P2/QA4]**

Iron is extracted in a blast furnace. The raw materials required are

- iron ore, which contains iron(III) oxide,  $\text{Fe}_2\text{O}_3$ ,
  - limestone,
  - coke (carbon),
  - air.
- (a) The coke first burns in air to form carbon dioxide.  
The carbon dioxide is then reduced by coke to produce carbon monoxide.  
The carbon monoxide reduces the iron(III) oxide to iron.  
Write equations for
- (i) the reduction of carbon dioxide by coke, [1]  
(ii) the reduction of iron(III) oxide to iron by carbon monoxide. [1]
- (b) Why is limestone added to the blast furnace? [1]
- (c) Another ore of iron contains an oxide with the formula  $\text{Fe}_3\text{O}_4$ .  
Calculate the percentage by mass of iron in  $\text{Fe}_3\text{O}_4$ . [2]
- (d) Iron can be obtained by the electrolysis of an aqueous acidified solution of iron(II) sulfate.  
The reactions at the electrodes are given.  
at the anode (positive electrode):  $4\text{OH}^- \rightarrow \text{O}_2 + 2\text{H}_2\text{O} + 4\text{e}^-$   
at the cathode (negative electrode):  $\text{Fe}^{2+} + 2\text{e}^- \rightarrow \text{Fe}$   
Which reaction is oxidation and which is reduction? Explain your answer. [2]
- (e) Attaching magnesium strips to the iron hulls of ships can lower their rate of rusting.  
Explain how the magnesium stops the iron from rusting. [2]
- (f) Aqueous iron(II) chloride is one of the products formed when iron reacts with hydrochloric acid.  
Construct an equation for this reaction. [1]

**SOLUTION**

- (a) (i)  $\text{CO}_2 + \text{C} \rightarrow 2\text{CO}$ . (Reduction=loss of oxygen)  
(ii)  $\text{Fe}_2\text{O}_3 + 3\text{CO} \rightarrow 2\text{Fe} + 3\text{CO}_2$ . ( $\text{Fe}_2\text{O}_3$  loses oxygen and charge of Fe decreases from +3 to 0)
- (b) Limestone is added to form CaO which reacts with silica impurities ( $\text{CaO} + \text{SiO}_2 \rightarrow \text{CaSiO}_3$ )
- (c) %age by mass of Fe =  $[(56 \times 3) / 232] \times 100 = 72.4\%$  (Mr of  $\text{Fe}_3\text{O}_4 = (56 \times 3) + (16 \times 4) = 232$ )
- (d) At the anode, oxidation is taking place as electrons are lost and oxidation number of oxygen increases while at the cathode, reduction is taking place as  $\text{Fe}^{2+}$  ion gains electrons and oxidation number of iron also decreases to 0
- (e) Since Mg is more reactive than Fe, it reacts with moisture and oxygen in place of Fe and corrodes preferentially. This process is known as sacrificial protection
- (f)  $\text{Fe} + 2\text{HCl} \rightarrow \text{FeCl}_2 + \text{H}_2$ .

## 9.2 Reactivity Series

15

[J06/P2/QA4/a,b,c]

This question is about calcium compounds.

- (a) Write the equation for the thermal decomposition of calcium carbonate. One of the products of this reaction is calcium oxide. [1]
- (b) When water is added to calcium oxide, calcium hydroxide is formed. [1]
- (i) Write the equation for the reaction between water and calcium oxide. [1]
- (ii) Solid calcium hydroxide reacts slowly with carbon dioxide. Name the calcium containing product of this reaction. [1]
- (c) State one large scale use of calcium hydroxide. [1]

### SOLUTION

- (a)  $\text{CaCO}_3 \rightarrow \text{CaO} + \text{CO}_2$ .
- (b) (i)  $\text{CaO} + \text{H}_2\text{O} \rightarrow \text{Ca(OH)}_2$ .
- (ii) Calcium carbonate  
( $\text{Ca(OH)}_2 + \text{CO}_2 \rightarrow \text{CaCO}_3 + \text{H}_2\text{O}$ .)
- (c) It is used to neutralize acidic soil  
(Other large scale uses: Making mortar/making plaster/for lime wash/softening water/reduce soil acidity/manufacture of sodium carbonate/washing soda/making bleaching powder/removing acidic gases in industry)

16

[J07/P2/QA7/b,c]

- (b) Calcium oxide is manufactured by the decomposition of calcium carbonate. Write the equation for this decomposition. [1]
- (c) A student investigates the decomposition of five different metal carbonates. The diagram shows the apparatus the student uses.

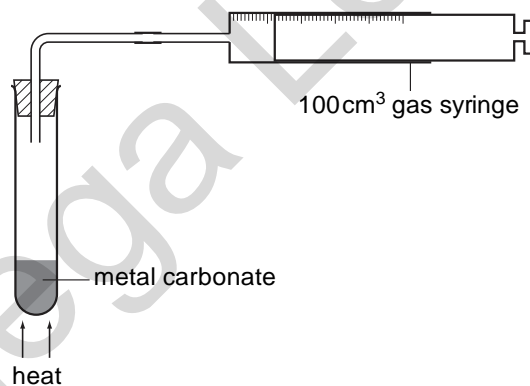

The student heats a 0.010 mol sample of each carbonate using the blue flame of the same Bunsen burner. She measures the time it takes for 100 cm<sup>3</sup> of gas to be collected in the gas syringe. The table shows her results.

| Carbonate                | time taken to collect 100 cm <sup>3</sup> of gas / s |
|--------------------------|--|
| metal <b>U</b> carbonate | 25   |
| metal <b>V</b> carbonate | 100  |
| metal <b>X</b> carbonate | 300  |
| metal <b>Y</b> carbonate | no gas produced after 1000 seconds                   |
| metal <b>Z</b> carbonate | 50   |

The student used calcium carbonate, copper (II) carbonate, magnesium carbonate, sodium carbonate and zinc carbonate.

Complete the table to show the identity of each metal **U**, **V**, **X**, **Y** and **Z**.

| Metal    | name to metal |
|----------|---------------|
| <b>U</b> | .....         |
| <b>V</b> | .....         |
| <b>X</b> | .....         |
| <b>Y</b> | .....         |
| <b>Z</b> | .....         |

Explain how you used the student's results to identify each metal.

[3]

**SOLUTION**

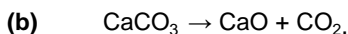

(c)

| metal    | name of metal |
|----------|---------------|
| <b>U</b> | Copper        |
| <b>V</b> | Magnesium     |
| <b>X</b> | Calcium       |
| <b>Y</b> | Sodium        |

The more reactive the metal, the longer the time taken to decompose

(More reactive metal carbonates are more stable to heating and take longer time to decompose)

The more reactive the metal, the longer the time taking to decompose (more reactive metal carbonates are more stable to heating and take longer time to decompose).

**17**

**[N07/P2/QA6/a]**

The diagram shows the inside of a firework rocket.

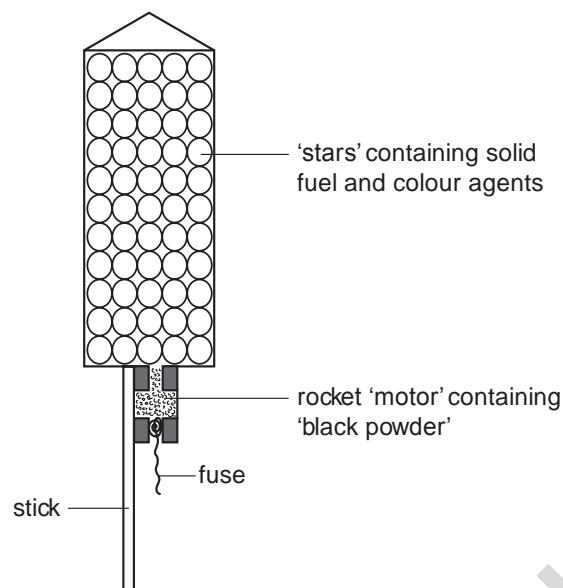

- (a) Black powder is a mixture of charcoal, potassium nitrate and sulphur. When black powder is ignited, the potassium nitrate decomposes to form potassium nitrite,  $\text{KNO}_2$ , and oxygen. Write the equation for the decomposition of potassium nitrate. [1]

**SOLUTION**

- (a)  $2\text{KNO}_3 \rightarrow 2\text{KNO}_2 + \text{O}_2$ .  
(All metal nitrates of group 1 elements form metal nitrites and oxygen on decomposition)

**18 [N07/P2/QB10/c]**

- (c) Calcium carbonate decomposes in the furnace. Write an equation for the thermal decomposition of calcium carbonate. Include state symbols. [1]

**SOLUTION**

- (c)  $\text{CaCO}_3(\text{s}) \rightarrow \text{CaO}(\text{s}) + \text{CO}_2(\text{g})$ .

**19 [J08/P2/QA5/b]**

- (b) The heat from the combustion of phosphorus provides enough energy for the decomposition of potassium chlorate(V) to oxygen and potassium chloride. Construct the equation for the decomposition of potassium chlorate(V). [2]

**SOLUTION**

- (b)  $2\text{KClO}_3 \rightarrow 2\text{KCl} + 3\text{O}_2$ .

**20** [J09/P2/QB11/b]

(b) The table shows part of the reactivity series of metals.

| metal | relative reactivity |
|-------|---------------------|
| zinc  | most reactive       |
| iron  | ↓                   |
| tin   | least reactive      |

An iron object plated with either zinc or tin will **not** rust.

- (i) Suggest how tin stops iron from rusting. [1]  
 (ii) An iron object plated with tin will start to rust if the layer of tin is scratched. An iron object plated with zinc will not rust if the layer of zinc is scratched. Use the information in the table to explain these two observations. [3]

**SOLUTION**

- (b) (i) Tin makes a protective layer, which stops oxygen and water to come in contact with iron  
 (ii) If a layer of tin is scratched or removed, oxygen and water can come in contact with iron and it will rust. However, if zinc is even slightly coated over iron, it reacts with oxygen and water first, being more reactive than iron and hence prevent iron from rusting

**21** [N10/P2/QB8/a(i)]

Magnesium is a reactive metal.

- (a) (i) Name the products formed when magnesium reacts with steam. [1]

**SOLUTION**

- (a) (i) Magnesium oxide and hydrogen

**22** [N10/P2/QB8/c,d]

(c) The equation shows the reaction which occurs when magnesium carbonate is heated.

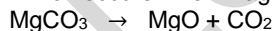

State the name given to this type of chemical reaction. [1]

(d) A student compared the action of heat on three solid metal carbonates. She heated each carbonate using the apparatus shown below. In each case, she recorded the length of time taken for the limewater to turn milky.

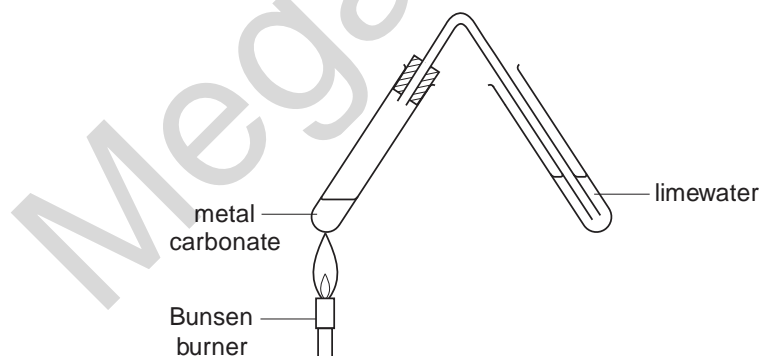

- (i) State one factor that must be kept constant if the speeds of reaction are to be compared in a fair way. [1]

- (ii) The time taken for the limewater to turn milky for each metal carbonate is shown in the table.

| metal carbonate     | time taken for the limewater to turn milky / s |
|---------------------|--|
| copper carbonate    | 10   |
| magnesium carbonate | 40   |
| zinc carbonate      | 24   |

Describe and explain these results in terms of the reactivity of the metals. [2]

**SOLUTION**

- (c) Thermal decomposition  
 (d) (i) **The** amount of carbonate used should be kept constant  
 (ii) Order of decomposition = Copper carbonate > Zinc carbonate > Magnesium carbonate  
 This shows that the less reactive the metal, **in the reactivity series** the faster the rate of decomposition

**23 [J11/P2/QA1/d]**

Choose from the following compounds to answer the questions below.

Ammonia                      carbon monoxide                      copper(II) carbonate                      copper(II) chloride  
 copper(II) sulfate                      sodium chloride                      sodium hydroxide                      sodium sulfate  
 sulfur dioxide                      sulfuric acid                      zinc carbonate                      zinc nitrate

Each compound can be used once, more than once or not at all.

Which compound

- (d) is a white solid that decomposes on heating to form carbon dioxide? [1]

**SOLUTION**

- (d) Zinc carbonate  
 Metal carbonates **decompose** to form metal oxides and CO<sub>2</sub> gas where as CuCO<sub>3</sub> is **not** a white solid but it is **green**.

**24 [J11/P2/QB9/a,b(i),c]**

Copper is a transition metal. It is used both in its pure form and in alloys.

- (a) The physical properties of copper can be explained in terms of metallic bonding. Describe, with the aid of a labelled diagram, the metallic bonding in copper. [3]  
 (b) (i) Explain why copper is a good electrical conductor. [1]  
 (c) Name an alloy that contains copper. [1]

**SOLUTION**

- (a)

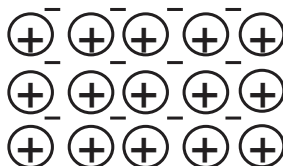

Positive ions are closely packed surrounded by a sea of delocalized electrons. The attraction between positive ions and electrons is called metallic bonding

- (b) (i) Due to the presence of delocalized electrons  
 (c) Brass

Other options can be; **Bronze, gliding metal, Muntz metal, yellow metal, bell metal, cupro-nickel, gunmetal, speculum metal, (cupro) nickel-silver, duralumin, smart alloy, gold alloy.**

**25**

**[J12/P2/QB7/b]**

Many carbonates thermally decompose to form carbon dioxide and an oxide.  
Copper carbonate forms carbon dioxide and copper oxide.

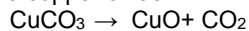

Six 2.00 g samples of carbonates are heated strongly until there is no further change in mass. The table shows the mass of solid remaining at the end of the heating.

| carbonate            | mass before heating / g | mass after heating / g |
|----------------------|-------------------------|------------------------|
| calcium carbonate    | 2.00                    | 1.12                   |
| copper(II) carbonate | 2.00                    | 1.29                   |
| iron(II) carbonate   | 2.00                    | 1.24                   |
| magnesium carbonate  | 2.00                    | 0.95                   |
| sodium carbonate     | 2.00                    | 2.00                   |
| zinc carbonate       | 2.00                    | 1.30                   |

- (b) The thermal stability of the carbonates is related to the reactivity of the metal. Which carbonate is the **least** thermally stable? [1]

**SOLUTION**

- (b) Copper (carbonate)

**26**

**[N12/P2/QA1/b(iv)]**

- (b) (iv) is formed by the thermal decomposition of limestone, [1]

**SOLUTION**

- (b) (iv)  $\text{CO}_2$   
( $\text{CaCO}_3$ /limestone decomposes to form  $\text{CaO}$  and  $\text{CO}_2$ )

**27**

**[N12/P2/QA2/a]**

A student heated different mixtures of metals and metal oxides.  
The table shows his results.

| mixture                | reacts or no reaction |
|------------------------|-----------------------|
| iron(III) oxide + zinc | Reacts                |
| lead(II) oxide + iron  | Reacts                |
| lead(II) oxide + zinc  | Reacts                |
| magnesium oxide + zinc | no reaction           |

- (a) (i) Predict the order of reactivity of the metals iron, lead, magnesium and zinc.  
least reactive  $\leftrightarrow$  most reactive [1]
- (ii) Construct the equation for the reaction of iron(III) oxide,  $\text{Fe}_2\text{O}_3$ , with zinc. The products are zinc oxide,  $\text{ZnO}$ , and iron. [1]

**SOLUTION**

- (a) (i) lead < iron < zinc < magnesium



- (b) (ii)  $\text{Fe}_2\text{O}_3 + 3\text{Zn} \rightarrow 3\text{ZnO} + 2\text{Fe}$   
 (i) Aluminium forms a nonporous oxide layer which is strongly fixed to its surface and is unreactive with both water and acids  
 (ii) Aluminium is strong, light-weight and a low density metal

**28** [J13/P2/QA6/d]

- (d) Copper powder is added to aqueous silver nitrate.  
 Predict whether or not a reaction will take place. Explain your answer. [1]

**SOLUTION**

- (d) Reaction takes place because copper is more reactive than silver

**29** [N13/P2/QA1/d]

- (d) is higher than sodium in the reactivity series, [1]

**SOLUTION**

- (d) Potassium

**30** [N14/P2/QA5/a]

The table below shows the reactivity of five metals with either cold water or steam or with both.

| metal     | reactivity   |
|-----------|--|
| barium    | reacts rapidly with cold water                           |
| copper    | no reaction with steam or cold water                     |
| magnesium | reacts very slowly with cold water but reacts with steam |
| sodium    | reacts very rapidly with cold water                      |
| nickel    | only reacts when powdered and heated strongly in steam   |

- (a) Deduce the order of reactivity of these metals using the information in the table.

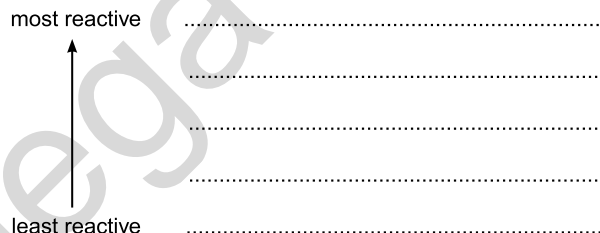

**SOLUTION**

- (a) Sodium      Barium      Magnesium      Nickel      Copper

[1]

### 9.3 Extractions Of Metals

31

[N05/P2/QB11/a,b]

The diagram below shows an experiment in which steam was passed over hot iron filings. The products of the reaction are iron oxide, Fe<sub>3</sub>O<sub>4</sub>, and a gas which burns with a blue flame.

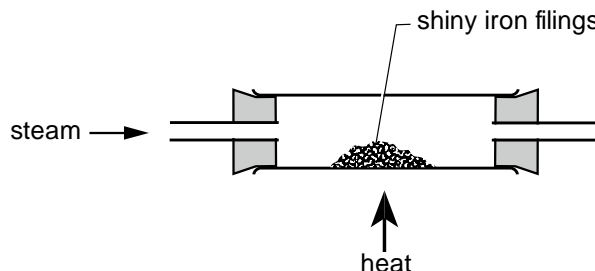

- (a) Write an equation, including state symbols, for the reaction and describe what you would see as the iron reacts with the steam [3]
- (b) Describe how the observations would be different if the experiment was repeated using each of the following two metals in place of the iron filings. [3]
- (i) magnesium
- (ii) copper

#### SOLUTION

- (a)  $3\text{Fe(s)} + 4\text{H}_2\text{O(g)} \rightarrow \text{Fe}_3\text{O}_4\text{(s)} + 4\text{H}_2\text{(g)}$ .  
The hot iron filing glows, turns black and finally reddish brown. A colorless, odorless gas is evolved and burns with a blue flame when ignited at the mouth of test tube.
- (b) (i) A dazzling white light is seen and white powder is formed  
(*Mg reacts much faster*)
- (ii) No light energy evolved. Reddish brown copper filings turn to black powder

32

[J11/P2/QB9/d]

- (d) Many millions of tonnes of copper are recycled every year.  
Describe some of the advantages and disadvantages of recycling copper. [3]

#### SOLUTION

- (d) **Advantages:**
1. It saves copper resources
  2. Reduces pollution caused by mining
  3. Less energy is used
  4. Saves more land for other uses such as agriculture
- Disadvantages:**
1. Collecting scrap requires energy
  2. Recycled copper needs to be purified

33

[J12/P2/QA3/a]

The typical composition of solid domestic waste in a city is shown below.

| type of solid waste          | percentage by mass |
|------------------------------|--------------------|
| glass                        | 9                  |
| metals                       | 8                  |
| organic waste including food | 22                 |
| paper                        | 38                 |
| plastics                     | 9                  |
| textiles                     | 2                  |
| Other                        | 12                 |

- (a) The most abundant metals in the solid waste are aluminium, copper and iron. Describe **two** advantages of recycling these metals. [2]

**SOLUTION**

- (a) Recycling of these metals saves finite resources and reduces disposal problem (Recycling saves energy, produces less litter and fewer toxic gases. Also, it reduces the need for mining and hence there is less scarring of the landscape)

**9.4 Iron**

**34 [J05/P2/QA2/c]**

- (c) When underwater, iron pipes will rust relatively rapidly.  
 (i) State the essential conditions needed for the rusting of iron.  
 (ii) Pieces of magnesium are often attached to underwater iron pipes. Explain how themagnesium protects the iron pipes against rusting. [3]

**SOLUTION**

- (c) (i) Oxygen and moisture  
*(Oxygen reacts with iron to form iron oxide in the presence of water acting as a catalyst)*  
 (ii) Magnesium is above iron in reactivity series and hence reacts with oxygen before iron does, protecting iron as long as magnesium is not completely used up.

**35 [J07/P2/QA1/e]**

Choose from the following oxides to answer the questions below.

aluminium oxide      calcium oxide      carbon monoxide      copper(II) oxide  
 sulphur dioxide      sulphur trioxide      vanadium(V) oxide

Each oxide can be used once, more than once or not at all.

Name an oxide which

- (e) when heated in a Blast Furnace with sand makes slag. [1]

**SOLUTION**

- (e) Calcium oxide  
 (CaO reacts with SiO<sub>2</sub> to make slag)

**36 [N09/P2/QB10]**

Iron is extracted by reducing iron ore in a blast furnace. The raw materials used are iron ore, coke, air and limestone.

- (a) Name an ore of iron. [1]  
 (b) Explain, by reference to the chemical reactions involved, why limestone is used in the blast furnace. [3]  
 (c) Coke burns in oxygen to form carbon dioxide. Explain, in terms of bond breaking and bond making, why this reaction is exothermic. [3]  
 (d) In the centre of the blast furnace iron(III) oxide,  $\text{Fe}_2\text{O}_3$ , is reduced by carbon monoxide to form iron and carbon dioxide. Near the bottom of the blast furnace the remaining iron(III) oxide is reduced by carbon to form iron and carbon monoxide. Write equations for both of these reactions. [2]  
 (e) When cold, the iron obtained from the blast furnace is brittle. How can this iron from the blast furnace be converted to mild steel? [1]

**SOLUTION**

- (a) Haematite  
 (Other possible answers: limonite / magnetite / siderite)  
 (b) Iron ore is mixed with coke and limestone and heated. Limestone (calcium carbonate) decomposes to calcium oxide and carbon dioxide. Carbon dioxide reacts with coke to produce carbon monoxide.  

$$\text{CO}_2 + \text{C} \rightarrow 2\text{CO}$$
 Carbon monoxide acts as a reducing agent and reacts with iron oxide to produce iron and carbon dioxide.  

$$3\text{CO} + \text{Fe}_2\text{O}_3 \rightarrow 3\text{CO}_2 + 2\text{Fe}$$
 Calcium oxide reacts with silicon dioxide to form slag which is tapped out  

$$\text{CaO} + \text{SiO}_2 \rightarrow \text{CaSiO}_3$$
 Also, calcium oxide is basic and, hence, reacts with acidic impurities.  
 (c) The bond between  $\text{O}_2$  breaks and bond between carbon and oxygen is formed. Bond breaking needs energy and is endothermic while bond making releases energy and is exothermic. As more energy is released while bond formation than the energy absorbed during bond breaking, the overall reaction is exothermic  
 (d)  $\text{Fe}_2\text{O}_3 + 3\text{CO} \rightarrow 2\text{Fe} + 3\text{CO}_2$   
 $\text{Fe}_2\text{O}_3 + 3\text{C} \rightarrow 2\text{Fe} + 3\text{CO}$   
 (e) Brittleness of iron is a result of high carbon contents. To reduce the amount of carbon, pure oxygen is blown into the molten iron, which reacts with carbon to change it into gaseous carbon monoxide or carbon dioxide, thus reducing the carbon content to produce mild steel

**37 [N10/P2/QA1/a(ii)]**

Choose from the following list of metals to answer the questions below.

**Aluminium iron lead magnesium**  
**Potassium silver vanadium**

Each metal can be used once, more than once or not at all.

Which metal

- (iv) is a sacrificial metal used to prevent iron pipes from rusting, [1]

**SOLUTION**

- (a) (iv) Magnesium Since Mg is more reactive than Fe, it is used as a sacrificial metal to prevent the rusting of iron pipes.

**38 [N11/P2/QA1/f]**

Choose from the following list of elements to answer the questions below.

**Calcium chlorine hydrogen iodine**  
**Nickel sodium vanadium zinc**

Each element can be used once, more than once, or not at all.

Which element

(f) can be used in the sacrificial protection of iron? [1]

**SOLUTION**

(f) Zinc  
Since zinc is **more reactive** than iron, it **would preferably react** thus iron remain protected from corrosion

**39** [J12/P2/QB7/d(ii)]

(d) (ii) Explain why calcium oxide is used in a blast furnace. [1]

**SOLUTION**

(d) (ii) Calcium oxide reacts with  $\text{SiO}_2$  (sand) and helps to remove it as slag  
Reacts with sand to make slag.

**40** [J14/P2/QA1/a]

Choose from the following gases to answer the questions below.

**CCl<sub>4</sub>**      **CH<sub>4</sub>**      **CO**      **CO<sub>2</sub>**      **H<sub>2</sub>**  
**N<sub>2</sub>**      **NH<sub>3</sub>**      **O<sub>2</sub>**      **SO<sub>2</sub>**

Each gas can be used once, more than once or not at all.

Which gas is

(a) used in making steel, [1]

**SOLUTION**

(a)  $\text{O}_2$   
(Oxygen oxidizes dissolved impurities so that they can be removed)

**41** [J14/P2/QA5/a]

Haematite, limestone and coke are heated together in a blast furnace in the manufacture of iron.

(a) State why each of the following compounds are needed in a blast furnace.  
haematite  
limestone coke [3]

**SOLUTION**

(a) **Haematite** – It is the iron ore which is reduced to form iron impurities (such as  $\text{SiO}_2$ ).  
**Coke** – Forms carbon monoxide which reduces the iron ore.

**42** [J14/P2/QB9/e]

(e) At room temperature iron will rust in moist air.  
Describe and explain how galvanising iron prevents rusting. [2]

**SOLUTION**

(e) Iron is galvanized by covering it with a layer of zinc. This prevents moisture and air to come in contact with the iron. Also, zinc is more reactive than iron and hence reacts with moisture and air in preference to the iron.

## 9.5 Aluminium

**43** [N08/P2/QA6/c,d,e]

- (c) In the production of aluminium, sodium hydroxide is used to separate aluminium oxide from the impurities in the bauxite ore. The main impurity in the ore is iron(III) oxide. Aluminium oxide is an amphoteric oxide whilst iron(III) oxide is a basic oxide. Suggest how these two oxides can be separated by the addition of aqueous sodium hydroxide. [2]
- (d) Aluminium is extracted by the electrolysis of a mixture of molten aluminium oxide and cryolite. What is the function of the cryolite? [1]
- (e) Acidic foods can be safely packed in aluminium containers. Explain why the acid in the food does not attack the aluminium, despite the fact that aluminium is a reactive metal. [2]

### SOLUTION

- (c) Bauxite is heated with sodium hydroxide solution. Aluminium oxide dissolves in sodium hydroxide which is removed by filtration, whereas iron (III) oxide being insoluble in sodium hydroxide, is separated as a residue.
- (d) Cryolite lowers the melting temperature of aluminium oxide from about 2200 C to 900c.
- (e) Aluminium is covered by a porous,tough and non reactive layer of aluminium oxide.

**44** [J09/P2/QB11/c,d]

- (c) Explain why aluminium will **not** corrode in the presence of oxygen and water. [1]
- (d) State a use of aluminium and explain why this metal is particularly suited for the stated use. [2]

### SOLUTION

- (c) Aluminium has a non porous, hard layer of aluminium oxide on it's surface which prevents contact with oxygen and water
- (d) It is used to make aircraft bodies because it is light weight and strong  
(Other possible answers: drinks cans → will not react with water / acids  
Car bodies → will not corrode  
Electricity cables → lightweight / good conductor of electricity)

**45** [N10/P2/QA1/a(ii)]

- (a) Choose from the following list of metals to answer the questions below.  
**aluminium      iron      lead      magnesium**  
**potassium      silver      vanadium**  
Each metal can be used once, more than once or not at all.  
Which metal  
(ii) forms a protective oxide layer on its surface, [1]

### SOLUTION

- (a) (ii) Aluminium  
Aluminium reacts with oxygen to form a hard and impermeable oxide layer

**46** [N12/P2/QA2/a,b(i,ii)]

- (b) (i) Explain why aluminium appears to be unreactive. [2]

(ii) Explain why aluminium is used in the manufacture of aircraft. [1]

**SOLUTION**

- (b) (i) Aluminium forms a nonporous oxide layer which is strongly fixed to its surface and is unreactive with both water and acids  
(ii) Aluminium is strong, light-weight and a low density metal

**47** [J13/P2/QA3/e(i)]

(e) (i) State one other reason why aluminium is used in the manufacture of aircraft. [1]

**SOLUTION**

- (e) (i) Low density

**48** [J13/P2/QA3/e(ii)]

(e) (ii) Explain why aluminium does not corrode very easily. [2]

**SOLUTION**

- (e) (ii) Aluminium has a non porous oxide layer on its surface which is impermeable to water and air.

**49** [N13/P2/QB6/b,c(i,ii)]

- (b) What properties of aluminium make it useful for  
(i) making aircraft,  
(ii) making electricity cables. [2]
- (c) (i) Explain why aluminium does not react with aqueous copper(II) sulfate. [2]  
(ii) When a few drops of aqueous sodium chloride are added to a mixture of aluminium and aqueous copper(II) sulfate, a vigorous reaction occurs.  
copper(II) sulfate + aluminium → aluminium sulfate + copper  
What type of reaction is this? [1]

**SOLUTION**

- (b) (i) Low density  
(ii) Good electrical conductivity
- (c) (i) It has a non porous,(tough) unreactive oxide layer on its surface  
(ii) Displacement / redox

**50** [N15/P2/QB7/f]

- (f) Aluminium is extracted by the electrolysis of molten aluminium oxide dissolved in cryolite.  
Construct the equation for the reaction at  
(i) the anode (positive electrode), [1]  
(ii) the cathode (negative electrode). [1]

**SOLUTION**

- (f) (i)  $2\text{O}^{2-} \rightarrow \text{O}_2 + 4\text{e}^-$ . (Oxidation takes place at anode)  
(ii)  $\text{Al}^{3+} + 3\text{e}^- \rightarrow \text{Al}$ . (Reduction takes place at cathode)

## UNIT-10 ATOMSPHERE AND ENVIRONMENT

### 10.1 Air

**1** [N06/P2/QA5/a(i),b(i),c]

The diagram shows the stages in water purification.

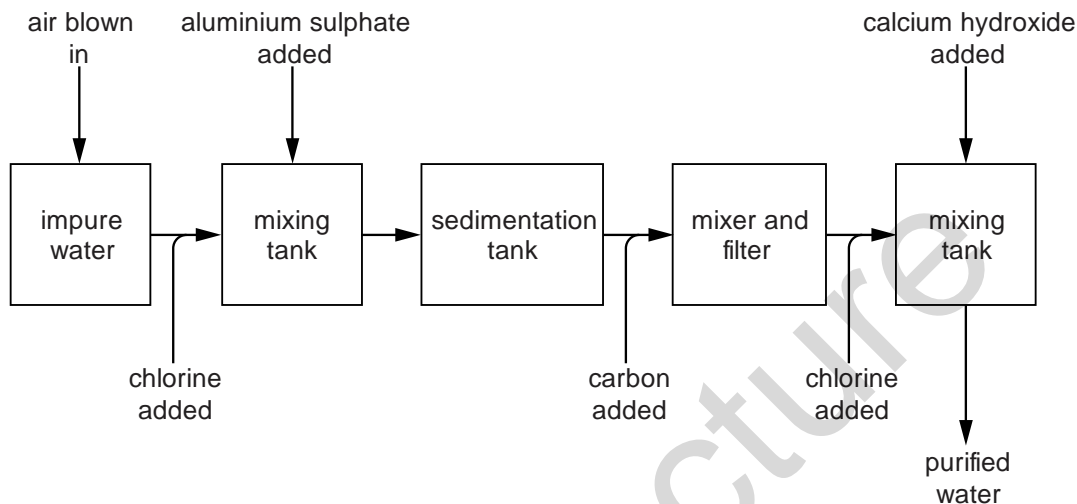

- (a) After the air is blown in, the impure water contains iron(III) ions.  
(i) What is the approximate percentage of oxygen in the air? [1]
- (b) Aluminium sulphate is added to clump tiny particles of clay together to form larger particles of solid.  
(i) Suggest how the solids are separated from the water. [1]
- (c) Why are the following added during the water purification process?  
(i) carbon [1]  
(ii) chlorine [1]

#### SOLUTION

- (a) (i) 20%
- (b) (i) Solid particles are removed from water by filtration or sedimentation.  
(ii)  $Al_2(SO_4)_3$
- (c) (i) To remove tastes/odours  
(Other possible answer: absorbs colors)  
(ii) To sterilize water by killing bacteria  
(Other possible answer: to disinfect water by killing germs)

**2** [N09/P2/QB9/c]

The diagram shows the carbon cycle.



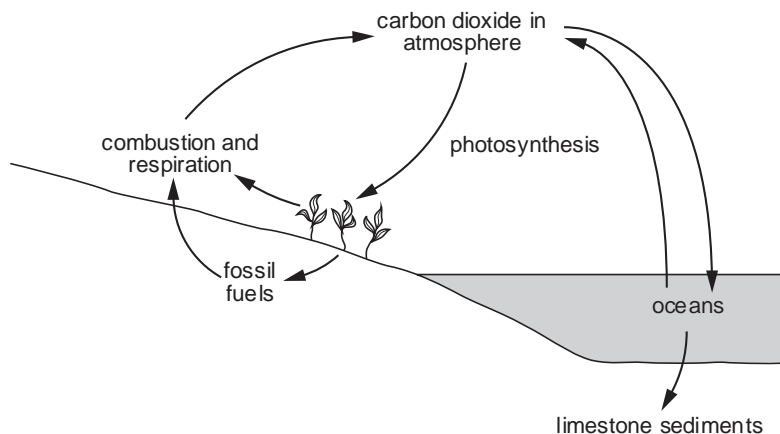

- (c) Many scientists think that the burning of hydrocarbons such as octane, C<sub>8</sub>H<sub>18</sub>, contributes to climate change.
- (i) Write an equation for the complete combustion of octane. [1]
- (ii) Why do some scientists think that the burning of hydrocarbons contributes to climate change? [1]

**SOLUTION**

- (c) (i)  $C_8H_{18} + 12\frac{1}{2} O_2 \rightarrow 8CO_2 + 9H_2O$
- (ii) Hydrocarbons burn to produce CO<sub>2</sub> which is a green house gas. It increases the global temperature causing ice caps to melt and increases sea level

**3 [N11/P2/QB6/c,d]**

- (c) Many fertilisers are ammonium salts. Explain why adding calcium hydroxide to the soil can cause the loss of nitrogen from the ammonium salts added as fertilisers. [2]
- (d) Fertilisers such as ammonium nitrate and ammonium phosphate are solids. They can get into lakes and cause excessive growth of algae.
- (i) Explain how these fertilisers get into lakes. [2]
- (ii) What name is given to the enrichment of lakes with nitrates and phosphates which leads to the death of plant and animal life in the lakes? [1]

**SOLUTION**

- (c) Calcium hydroxide reacts with ammonium salts to produce ammonia a gas which escapes into the atmosphere resulting in loss of nitrogen content of soil.
- (d) (i) Fertilisers, being soluble in water are washed away with rainwater into the lakes
- (ii) Eutrophication

**4 [J12/P2/QA4/a,b,d]**

Many electricity generating power stations burn fossil fuels. The combustion of these fuels produces waste gases called flue gas. The flue gas contains nitrogen oxides, sulfur dioxide and carbon dioxide.

Nitrogen oxides and sulfur dioxide contribute towards acid rain and must be removed from the flue gas before it is allowed to reach the atmosphere.

- (a) One of the nitrogen oxides is nitrogen monoxide, NO.
- (i) Nitrogen monoxide is formed by the direct reaction between oxygen and nitrogen.  
Construct the equation for this reaction. [1]
- (ii) When cold nitrogen monoxide comes into contact with oxygen it forms nitrogen dioxide, NO<sub>2</sub>. Construct the equation for this reaction. [1]
- (b) Some power stations spray the flue gas with seawater. This removes about 99% of the nitrogen dioxide and sulfur dioxide.  
The gases react with water to form aqueous acids. Nitrogen dioxide forms nitric acid and another acid with the formula, HNO<sub>2</sub>.  
Construct the equation for this reaction. [1]
- (d) Suggest **two** advantages of treating flue gas with seawater rather than calcium carbonate. [2]

**SOLUTION**

- (a) (i)  $N_2 + O_2 \rightarrow 2NO$   
(ii)  $2NO + O_2 \rightarrow 2NO_2$
- (b)  $2NO_2 + H_2O \rightarrow HNO_3 + HNO_2$
- (d) Sea water is relatively abundant and cheaper. Also, treating flue gas with sea water does not produce carbon dioxide and hence does not contribute to an increase in global warming (Other possible advantages: Obtaining sea water does not involve mining and landscape destruction and it removes more of the pollutant gases)

**5 [J12/P2/QA4/c]**

- (c) In other power stations the flue gases are reacted with moist calcium carbonate. This removes about 90% of the nitrogen dioxide and sulfur dioxide from the flue gas.
- (i) Sulfur dioxide reacts with calcium carbonate to form solid calcium sulfite, CaSO<sub>3</sub>.  
Suggest the name of the other product of this reaction. [1]
- (ii) Nitrogen dioxide reacts with calcium carbonate to form two salts.  
Suggest the name and formula of one of these salts. [2]

**SOLUTION**

- (c) (i) Carbon dioxide  
(ii) Calcium nitrate

**6 [N12/P2/QB9/a(ii)]**

Chlorine and sodium hydroxide are manufactured by the electrolysis of concentrated aqueous sodium chloride.

- (a) (ii) Explain the purpose of chlorine in water purification. [1]

**SOLUTION**

- (a) (ii) Chlorine is used for killing bacteria in water

**7 [N15/P2/QA3]**

Water for use in the home is treated using carbon and chlorine.

- (a) Explain the purpose of using carbon and chlorine in water treatment.  
Carbon

- Chlorine [2]
- (b) In some parts of the world, drinking water is purified by desalination. What is meant by the term *desalination*? [1]
- (c) River water may contain pollutants from agricultural sources. These pollutants may cause eutrophication. Give the names of two anions present in fertilisers which contribute to eutrophication. and [1]
- (d) An aqueous solution of barium chloride is added to a sample of water which contains sulfate ions. A white precipitate forms. Construct an ionic equation, including state symbols, for this reaction. [2]

**SOLUTION**

- (a) Carbon: Carbon is used to remove unpleasant odours. It adsorbs the microorganisms on its surface so that water is clean.
- Chlorine: Chlorine purifies water by directly killing micro-organisms
- (b) Desalination refers to removal of salt or mineral salts from the water
- (c) Nitrates and Phosphates (*nitrates and phosphate compounds kill the marine animals and plants*)
- (d)  $\text{BaCl}_{2(aq)} + \text{SO}_{4^{2-}(aq)} \rightarrow \text{BaSO}_{4(s)} + 2\text{Cl}^{-}(aq)$ .  
 $\text{Ba}^{+}(aq) + 2\text{Cl}^{-}(aq) + \text{SO}_{4^{2-}(aq)} \rightarrow \text{BaSO}_{4(s)} + 2\text{Cl}^{-}(aq)$   
 $\text{Ba}^{+}(aq) + \text{SO}_{4^{2-}(aq)} \rightarrow \text{BaSO}_{4(s)}$ .

**10.2 Water**

**8 [J05/P2/QA1/a]**

- Choose from the following substances to answer the questions below.
- |                 |                 |                  |                   |
|-----------------|-----------------|------------------|-------------------|
| aluminium oxide | ammonia         | bariumsulphate   | calcium carbonate |
| carbon monoxide | lead(II) iodide | nitrogen dioxide | silicon dioxide   |
- Each substance can be used once, more than once or not at all.
- Name a substance which
- (a) is a gas that causes acid rain, [1]

**SOLUTION**

- (a) Nitrogen dioxide  
 (Non metal oxides are acidic oxides;  
 $2\text{NO}_2 + \text{H}_2\text{O} \rightarrow \text{HNO}_2 + \text{HNO}_3$ .)

**9 [J05/P2/QB7/a,b]**

- Ozone, O<sub>3</sub>, is an atmospheric pollutant in the lower atmosphere but is beneficial higher up in the atmosphere.
- (a) How is ozone formed in the lower atmosphere? [1]
- (b) Ozone in the upper atmosphere is being depleted. Describe briefly how this is happening and some of the health problems caused by ozone depletion. [3]

**SOLUTION**

- (a) Ozone is formed by photochemical reactions.  
 (Alternative answer: electrical discharge during lightning in air)
- (b) Ozone is removed the reaction with chlorine atoms which are produced by the decomposition of CFC's  
 Ozone loss from atmosphere causes skin cancer, cataracts, crop damage, eye damage, etc.

10

[N05/P2/QB8]

This graph shows how the percentage of three of the gases in the Earth's atmosphere has changed over five thousand million years.

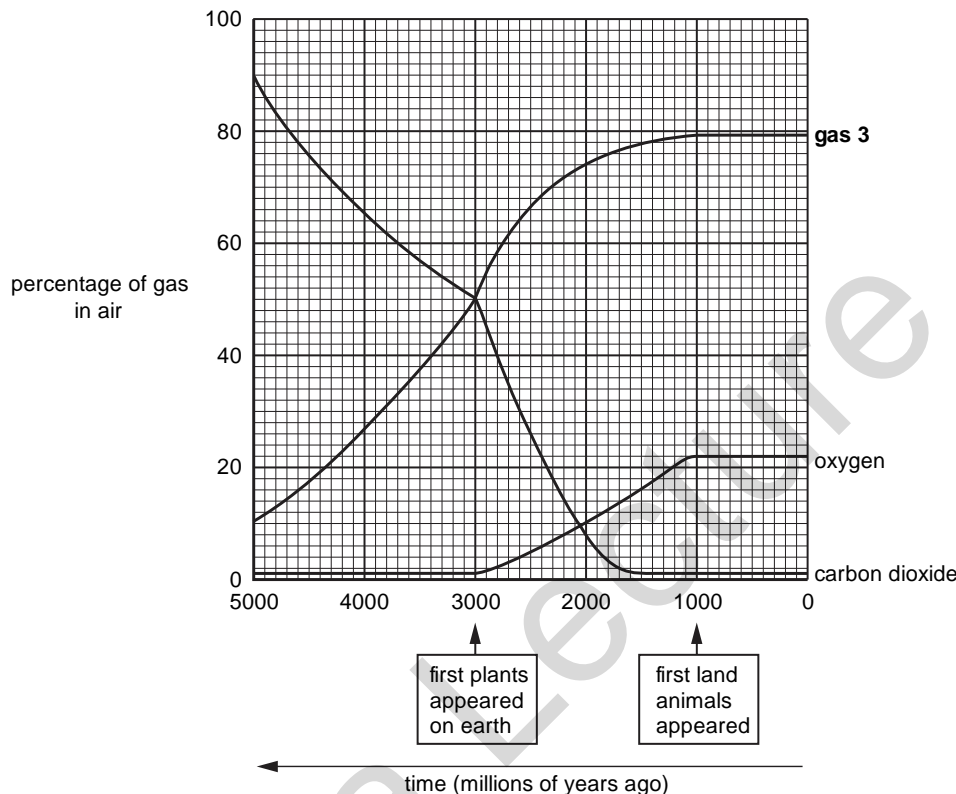

- Use information from the graph to answer the following questions.
- (a) (i) How long have the percentages of all gases in the atmosphere remained unchanged? [3]  
 (ii) Name **gas 3**. Give a reason for your answer.
- (b) (i) Describe how the percentages of carbon dioxide and oxygen have changed. [5]  
 (ii) Suggest an explanation for the changes that have taken place in carbon dioxide and oxygen percentages, identifying the processes involved and giving equations for any reactions. [2]
- (c) Oxygen is separated from air by fractional distillation. Outline how this separation takes place.

**SOLUTION**

- (a) (i) 1000 million years.  
 (ii) Nitrogen gas. The composition by volume of nitrogen in air mixture is approximately 79%
- (b) (i) CO<sub>2</sub> decreases gradually from 90% for over 2000 million years, then decreases sharply over another 1000 million years ago to about 1% and then remains constant.

Oxygen remains constant at 1% for 2000 million years and then increases rapidly to 21% in air over the next 2000 million years after which it remains constant

(ii) Photosynthesis began when green plants first appeared on earth 3000 million years ago. Green plants absorb CO<sub>2</sub> and water from the environment to produce sugar(glucose) and oxygen gas.

This caused the %age of CO<sub>2</sub> to decrease and %age of O<sub>2</sub> to increase in the atmosphere.

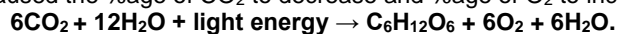

The oxygen produced is in turn absorbed by green plants for respiration to produce energy for the growth and in the process return carbon dioxide to the air

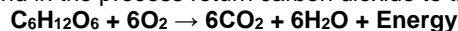

The relative %age of the two gases reach a constant ratio when animals appear 2000 million years later and the ratio is maintained by both the process respiration and photosynthesis.

11

[J06/P2/QA7]

Graph 1 shows how the average temperature at the Earth's surface may have changed over the last 150 thousand years.

Graph 2 shows how the percentage of carbon dioxide in the atmosphere may have changed over the last 150 thousand years.

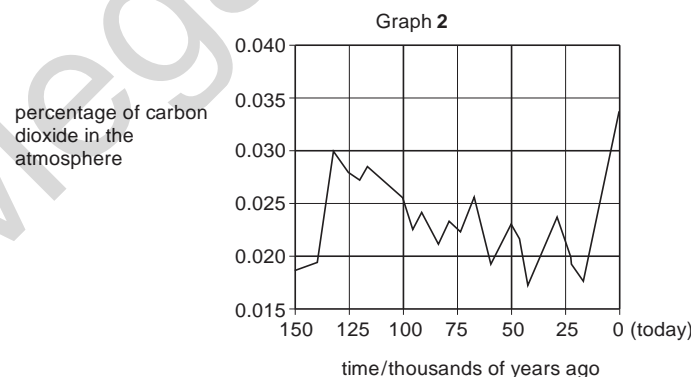
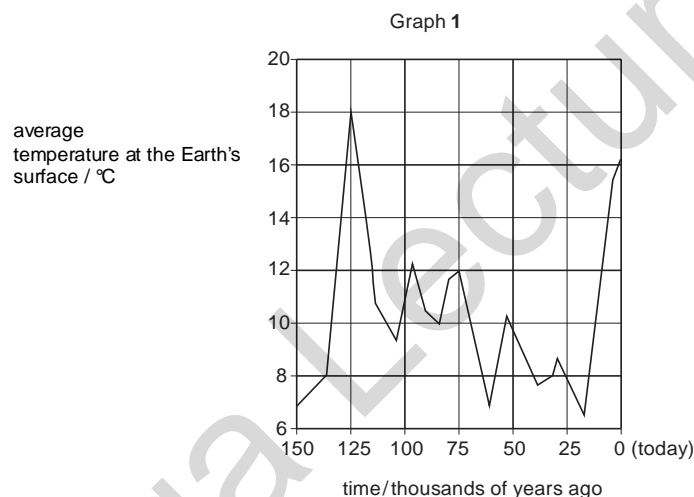

- (a) Carbon dioxide is a greenhouse gas. Scientists think that an increase in the greenhouse gases will result in global warming.  
 (i) Explain how graphs 1 and 2 support this statement. [1]  
 (ii) Describe **two** consequences of global warming. [2]
- (b) Draw a 'dot and cross' diagram for carbon dioxide. Show the outer shell electrons only. [2]
- (c) Chlorofluorocarbons, CFCs, are also greenhouse gases.  
 (i) Name **one** other greenhouse gas found in the atmosphere. [1]  
 (ii) State the origin of this greenhouse gas, named in part (i). [1]  
 (iii) Describe how the presence of CFCs in the upper atmosphere increases the amount of ultra-violet light reaching the Earth's surface. [2]

**SOLUTION**

- (a) (i) Along with the increase in the concentration of carbon dioxide, the average temperature also increases, as the two graphs are roughly similar  
 (ii) Global warming results in melting of polar ice which leads to rise in sea levels and hence partial or complete submersion of coastal areas.  
 It also disrupts climatic cycles leading to extreme climate effects such as floods and desertification

(b)

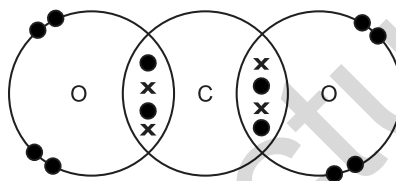

- (c) (i) Methane  
 (ii) Cow flatulence and decay of vegetation  
 (iii) Ozone layer in the stratosphere absorbs UV light and thus protects earth from harmful UV rays from the sun. CFCs present in the stratosphere causes ozone depletion by releasing a chlorine free radical(Cl) which reacts with ozone making the UV rays to reach the earth surface.

**12**

[J06/P2/QB8/a,b]

River water contains many substances including minerals, dissolved oxygen, organic material, nitrates and phosphates.

- (a) Give one source of phosphates in water. [1]  
 (b) Excess dissolved phosphates in river water cause *eutrophication*.  
 Describe the process of eutrophication. [3]

**SOLUTION**

- (a) Fertilizers or detergents  
 (b) Dissolved phosphates serve as nutrients to algae forming extensive algal blooms. The algae grows in layers on the surface of water and blocks sunlight from reaching the lower layers of plants and algae. Since lower layers cannot carry out photosynthesis without sunlight, they die away and aerobic bacteria decompose them by using oxygen from the water. The water plants and other aquatic life eventually die due to lack of oxygen.

13

[N06/P2/QA1/a(i),c]

The diagram shows the structures of various compounds.

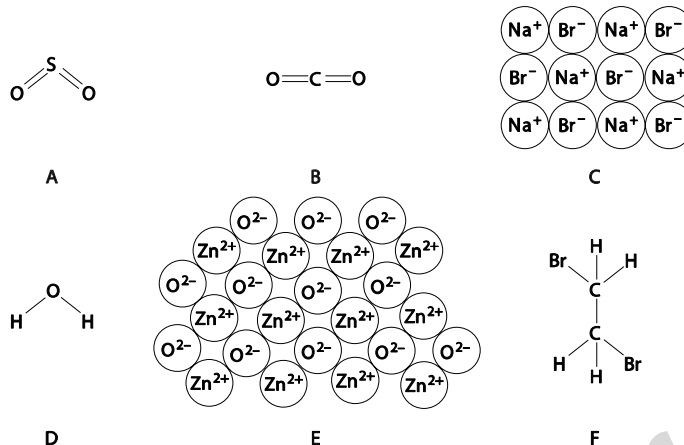

- (a) Use the letters **A** to **F** to answer the following.  
Each compound may be used once, more than once or not at all.
- (i) Which **one** of these compounds is most likely to contribute to acid rain? [1]
- (c) Carbon monoxide is a poisonous atmospheric pollutant.  
State how this gas gets into the air. [1]

**SOLUTION**

- (a) (i) **A**  
(SO<sub>2</sub> reaches the atmosphere and oxidizes to SO<sub>3</sub>. SO<sub>3</sub> dissolves in water to form sulphuric acid which causes acid rain)
- (c) CO is produced as a result of incomplete combustion of fossil fuels  
(Other possible answers: It is produced in car exhausts and gas fires as a result of incomplete combustion of hydrocarbons).

14

[N06/P2/QA6/b,c,d]

- (b) At a temperature of  $-5^{\circ}\text{C}$  and a pressure of 26 atmospheres, methane combines with water and forms an ice-like structure called methane hydrate.  
Large quantities of methane hydrate have been found underground.
- (i) Describe the arrangement and motion of the particles in solid methane hydrate. [2]
- (ii) The methane hydrate underground has not yet been extracted in large amounts.  
When it is extracted, large volumes of methane are released.  
Suggest **two** reasons why methane hydrate decomposes when it is extracted. [2]
- (iii) Describe how the presence of methane in the atmosphere may affect the environment. [1]
- (c) A very small quantity of methane is present in the atmosphere.  
State another source of this gas. [1]
- (d) State a use of methane. [1]

**SOLUTION**

- (b) (i) Particles are closely packed in an orderly pattern and only vibrate about their fixed positions.

- (ii) As methane hydrate is extracted, pressure decreases and temperature increases causing the forces between the molecules to weaken.
- (iii) Methane causes global warming  
(Other possible answers: methane causes melting of polar ice caps, melting of glaciers, desertification, rise in sea levels, extreme climate changes and changes in animal habitats)
- (c) Decomposition of vegetable matter by bacteria.  
(Other possible sources: paddy fields, marshes, cow flatulence, landfill sites)
- (d) Methane is used as fuel  
(Other possible uses: synthesis of gas, manufacture of ethyne, making carbon black, making hydrogen cyanide, making methanol, for cooking and heating purposes)

**15** [N06/P2/QB7/e]

- (e) State one major problem caused when the nitrates from fertilisers leach from the soil into streams and rivers. [1]

**SOLUTION**

- (a) Nitrogen has gained electrons and oxidation number of nitrogen has decreased  
(Reduction is gain of electrons and oxidation number of N changes from 0 to -3)
- (b)  $2\text{NO}_3^- + 12\text{H}^+ + 10\text{e}^- \rightarrow \text{N}_2 + 6\text{H}_2\text{O}$ .
- (e) Eutrophication  
(Eutrophication is the death of aquatic plants and animals due to increased algal activity on water surface and reduction of dissolved oxygen in water. This algal bloom is caused by leaching of excess nitrates in rivers)

**16** [J07/P2/QA4/c]

Structures of six organic compounds are shown.

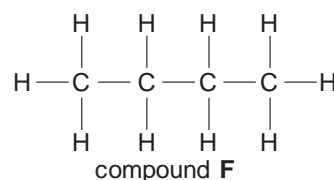
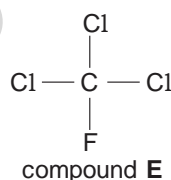
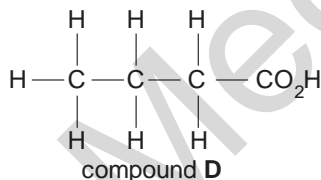
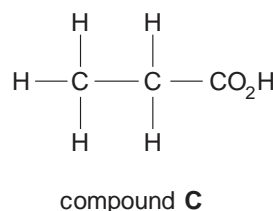
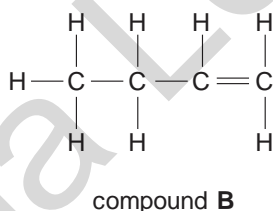
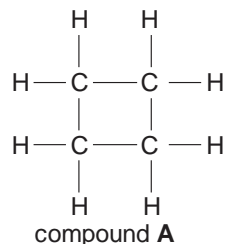

- (c) Which compound contributes to ozone depletion in the upper atmosphere? [1]

**SOLUTION**

- (c) E  
(CFC's are responsible for ozone layer depletion)



17

[N07/P2/QA1/b]

Choose from the following gases to answer the questions below.

Ammonia

butane

carbon dioxide

carbon

monoxidehydrogen

methane

nitrogen

nitrogen dioxide

oxygen

Each gas can be used once, more than once or not at all.

Which gas is

(b) used by plants in photosynthesis to form glucose,

[1]

**SOLUTION**

(b)

Carbon dioxide

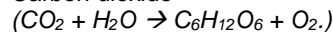

18

[N07/P2/QA6/b]

The diagram shows the inside of a firework rocket.

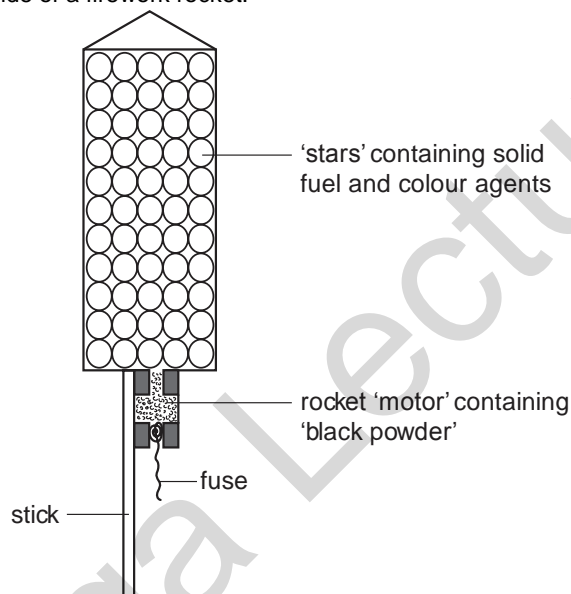

(b)

The oxygen liberated by the potassium nitrate oxidises the sulphur to sulphur dioxide. State one harmful effect of sulphur dioxide on the environment.

[1]

**SOLUTION**

(b)

Sulphur dioxide produces acid rain which corrodes buildings

(Other possible harmful effects: Kills trees and aquatic animals, causes breathing difficulties in humans)

19

[N07/P2/QB7/a,b]

The exhaust from an internal combustion engine contains the pollutant gases carbon monoxide and nitrogen dioxide.

(a)

Many vehicles have a catalytic converter fitted on their exhaust systems.

- Describe the chemical reactions which occur in the catalytic converter to reduce the emissions of carbon monoxide and nitrogen dioxide. [3]
- (b) Unburnt hydrocarbons such as heptane,  $C_7H_{16}$ , are oxidised in the catalytic converter. Write an equation for the complete combustion of heptane. [1]

**SOLUTION**

- (a) Carbon monoxide is converted to carbon dioxide and nitrogen is reduced to nitrogen  
 $2CO + 2NO_2 \rightarrow N_2 + 2CO_2$ .
- (b)  $C_7H_{16} + 11O_2 \rightarrow 7CO_2 + 8H_2O$ .  
(Complete combustion always produces carbon dioxide and water)

**20**

**[J08/P2/QA6/a,b]**

Sulphur dioxide,  $SO_2$ , and nitrogen dioxide,  $NO_2$ , are both atmospheric pollutants formed during the combustion of coal at a power station.

- (a) (i) State another source of sulphur dioxide as an atmospheric pollutant. [1]  
(ii) State another source of nitrogen dioxide as an atmospheric pollutant. [1]
- (b) Nitrogen dioxide and sulphur dioxide both cause acid rain. They are removed from the flue gases released from the power station by reaction with moist calcium carbonate in a process called flue gas desulphurisation.  
Calcium carbonate reacts with sulphur dioxide to make a solid called calcium sulphite and a gas.  
(i) What is the name of this gas? [1]  
(ii) Nitrogen dioxide reacts with calcium carbonate to make a solid. Suggest the name of this solid. [1]  
(iii) Describe one environmental effect of acid rain. [1]

**SOLUTION**

- (a) (i) burning of sulphur or metal sulphide / treatment of sulphide ores  
(Other possible answers: bacterial oxidation / burning of natural gas / volcanoes)  
(ii) Car exhausts  
(Other possible answers: lightning, high temperature furnaces, explosives)
- (b) (i) Carbon dioxide  
(Calcium carbonate decomposes to give  $CaO$  and  $CO_2$ )  
(ii) Calcium nitrite / nitrate  
(iii) Corrodes buildings  
(Other possible effects: Crop damage, breathing difficulties in humans)

**21**

**[J08/P2/QB7/d]**

- (d) State **one** environmental problem associated with the molecule  $C_2F_3Cl_3$ . [1]

**SOLUTION**

- (d) CFC's destroy the ozone molecules in the atmosphere

**22**

**[J09/P2/QB8/c,d]**

- (c) In addition to carbon dioxide the exhaust emissions contain both nitric oxide,  $NO$ , and carbon monoxide,  $CO$ .  
Describe how a catalytic converter can help to reduce the amounts of nitric oxide and carbon monoxide in the exhaust gases. [2]
- (d) State **one** environmental problem caused by nitrogen dioxide. [1]

**SOLUTION**

- (c) CO is converted to carbon dioxide while NO is converted to nitrogen CO + NO → CO<sub>2</sub> + ½N<sub>2</sub>.  
(d) Acid rain

**23** [J09/P2/QB10/b]

- (b) Eutrophication occurs in river water polluted by fertilisers.  
Describe the principal processes involved in eutrophication. [3]

**SOLUTION**

- (b) Water polluted by fertilizers causes rapid growth of algae which blocks the sunlight causing the underwater plants to die. Dead plants allow the bacterial growth to increase. Bacteria use up the oxygen causing aquatic animal to die due to lack of oxygen

**24** [N09/P2/QA1/a(iv)]

Choose from the following compounds to answer the questions below.

|                         |                       |                            |
|-------------------------|-----------------------|----------------------------|
| <b>ammonium sulfate</b> | <b>calcium oxide</b>  | <b>copper(II) chloride</b> |
| <b>ethanoic acid</b>    | <b>ethane</b>         | <b>nitrogen dioxide</b>    |
| <b>sodium iodide</b>    | <b>sulfur dioxide</b> |                            |

Each compound can be used once, more than once or not at all.

Which compound

- (a) (iv) is a pollutant arising from lightning activity, [1]

**SOLUTION**

- (a) (iv) Nitrogen dioxide  
(Nitrogen and oxygen react in lightning to produce nitrogen dioxide)

**25** [N09/P2/QA3/a]

- (a) State the approximate percentages of nitrogen and oxygen in dry air. [1]

**SOLUTION**

- (a) Nitrogen 79% and Oxygen 20%

**26** [N09/P2/QA6]

A thin layer of ozone, O<sub>3</sub>, is present high in the Earth's atmosphere.

- (a) Explain why the ozone layer is important in terms of human health. [2]  
(b) Chlorofluorocarbons, CFCs, catalyse the conversion of ozone to oxygen.  
Write the equation for this reaction. [1]  
(c) The graphs show how both the world CFC production and the amount of high level ozone at the South Pole have changed over the last 26 years.

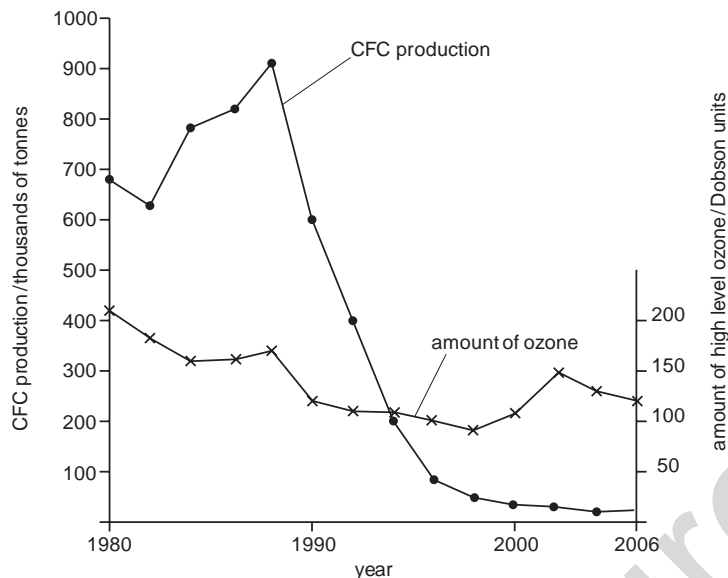

Fig. 3

- (i) Describe how the world production of CFCs has changed over the last 26 years. [2]  
 (ii) What evidence, if any, is there to indicate a link between the world CFC production and the amount of high-level ozone in the atmosphere at the South Pole? Explain your answer. [2]

**SOLUTION**

- (a) Ozone layer traps ultra violet radiation which cause skin cancer cataract and reduces effectiveness of the immune system.  
 (b)  $2O_3 \rightarrow 3O_2$ .  
 (c) (i) In 1980, production of CFC's was 680,000 tonnes, which decreased in 1982 to about 640,000 tonnes. From 1983 to 1988, production increased to 920,000 tonnes, after which it decreased sharply until 2000 when its production was only about 25,000 tonnes. From 2000 to 2006, it remained almost constant at minimum level.  
 (ii) As the production of CFC's increased, the amount of ozone declined between 1980 and 1988. From 1988 to 1998, ozone level declined even though the production of CFC's was decreasing during that time. From 1998 to 2006, the ozone level increased as expected due to decrease in CFC production.

The diagram shows the carbon cycle.

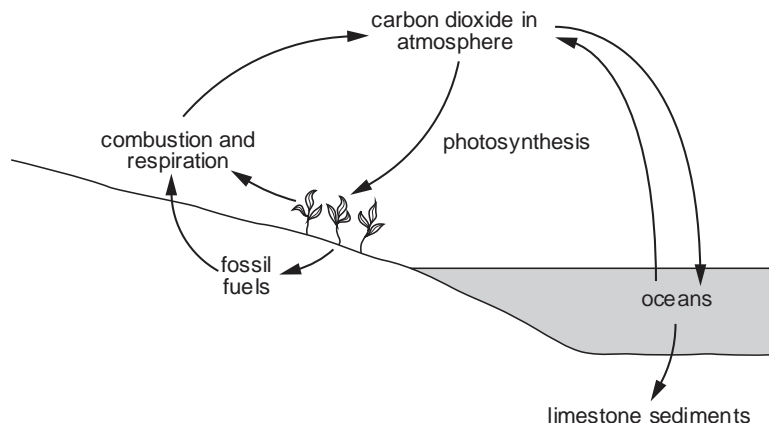

- (a) Describe the process of photosynthesis in simple terms. [2]  
 (e) Calcium carbonate is used in flue gas desulfurisation. Describe this process and explain why it is important for the environment. [2]

**SOLUTION**

- (a) Water through roots and carbon dioxide from air react to produce glucose and oxygen. This reaction takes place in the presence of sun light and chlorophyll is used as a catalyst  
 (e) Flue gas containing sulfur dioxide is made to react with calcium carbonate to produce calcium sulfite and carbon dioxide. Calcium sulfite oxidises to calcium sulfate. This avoids the escape of sulfur dioxide in atmosphere. This prevents the formation of sulfurous acid and, hence, acid rain which may erode metallic structures, harm crops and living species.

**28** [J10/P2/QA1/a,b,c]

Choose from the following compounds to answer the questions below.

- BaSO<sub>4</sub>**      **CH<sub>4</sub>**      **C<sub>2</sub>H<sub>4</sub>**      **C<sub>3</sub>H<sub>8</sub>**      **CO<sub>2</sub>**  
**CaCO<sub>3</sub>**      **CF<sub>3</sub>Cl**      **K<sub>2</sub>Cr<sub>2</sub>O<sub>7</sub>**      **MgSO<sub>4</sub>**      **NaCl**      **ZnSO<sub>4</sub>**

Each compound can be used once, more than once or not at all.

Which compound

- (a) is responsible for ozone depletion, [1]  
 (b) is formed by the bacterial decay of vegetable matter, [1]  
 (c) is used to remove sulfur dioxide in flue gas desulfurisation, [1]

**SOLUTION**

- (a) CF<sub>3</sub>Cl  
 When CFCs reach stratosphere, U.V light fall on them and they break into free radicals.  
 $CF_3Cl + U.V \text{ light} \rightarrow CF_3\cdot + Cl\cdot$   
 Highly reactive chlorine free radical then reacts with ozone (O<sub>3</sub>), destroying it.  
 $Cl\cdot + O_3 \rightarrow ClO\cdot + O_2$
- (b) CO<sub>2</sub>/CH<sub>4</sub>  
 Bacterial decay of organic matter produces CO<sub>2</sub> or CH<sub>4</sub>.
- (c) CaCO<sub>3</sub>  
 SO<sub>2</sub> is an acidic oxide. It reacts with CaCO<sub>3</sub> to produce solid CaSO<sub>3</sub>.

**29** [J10/P2/QB7/a]

Hydrazine,  $\text{N}_2\text{H}_4$ , is a liquid that has been used as a rocket fuel. It reacts with oxygen as shown in the equation.

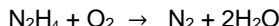

This reaction is highly exothermic.

- (a) Suggest why the combustion of hydrazine has very little environmental impact. [1]

**SOLUTION**

- (a) The gases produced are harmless and non polluting.

**30** [N10/P2/QA5/b(ii),c(i)]

- (b) (ii) Explain why carbon monoxide must not be allowed to escape from the furnace. [1]  
(c) (i) Write an equation for this reaction. [1]

**SOLUTION**

- (b) (ii) CO is a poisonous gas  
CO attacks red blood cells and combines irreversibly with haemoglobin to make carboxyhaemoglobin and hence oxygen carrying capacity of haemoglobin decreases  
(c) (i)  $\text{CO}_2 + \text{C} \rightarrow 2\text{CO}$

**31** [N10/P2/QB6/a,b]

The carbon cycle regulates the amount of carbon dioxide in the atmosphere.

- (a) Explain how the processes of photosynthesis and respiration help to regulate the amount of carbon dioxide in the atmosphere. [3]  
(b) Methane is an atmospheric pollutant which contributes to global warming.  
(i) Suggest **two** possible consequences of an increase in global warming. [2]  
(ii) Write an equation for the complete combustion of methane. [1]  
(iii) Methane is generally unreactive. Apart from combustion, state one other chemical reaction of methane. [1]

**SOLUTION**

- (a) During respiration oxygen is used up and  $\text{CO}_2$  is released while during photosynthesis  $\text{CO}_2$  is used up and oxygen is released. Amount of  $\text{CO}_2$  released in respiration roughly equals the amount of  $\text{CO}_2$  used in photosynthesis and hence helps in regulating the amount of  $\text{CO}_2$  in the atmosphere  
(b) (i) Melting of glaciers  
i.e rise of sea level and **also poor crop yield**  
(ii)  $\text{CH}_4 + 2\text{O}_2 \rightarrow \text{CO}_2 + 2\text{H}_2\text{O}$   
(iii)  $\text{CH}_4 + \text{Cl}_2 \rightarrow \text{CH}_3\text{Cl} + \text{HCl}$   
(c) (i) Larger molecules have higher boiling points  
(ii) High temperature (**550c and above**)  
Catalyst (aluminium oxide)

**32** [J11/P2/QA3/e]

- (e) Microorganisms in the soil convert ammonium nitrate into gaseous nitrous oxide,  $\text{N}_2\text{O}$ . This gas is a greenhouse gas.  
(i) Describe **two** possible consequences of an increasing concentration of greenhouse

- (ii) gases in the atmosphere. [2]  
Ammonium nitrate can be thermally decomposed in the laboratory to form nitrous oxide and one other product.  
Construct the equation for this decomposition. [1]

**SOLUTION**

- (e) (i) 1. Increased global warming would lead to an increase in atmospheric temperature  
2. Drastic climatic changes such as storms, tornadoes and deforestation other reasons include; rising of sea level due **to melting of glaciers**  
(ii)  $\text{NH}_4\text{NO}_3 \rightarrow \text{N}_2\text{O} + 2\text{H}_2\text{O}$

**33** [J11/P2/QA4/b,e(iii)]

- (e) (iii) Suggest one environmental problem associated with the presence of trifluoro-chloromethane in the atmosphere. [1]

**SOLUTION**

- (e) (iii) It destroys ozone layer causing global warming  
Chlorofluorocarbons **decompose** in upper atmosphere producing chlorine **free radical** which reacts with **ozone** destroying it

**34** [N11/P2/QA2/a,b,e]

Pure oxygen for industrial use is obtained from the air.

- (a) (i) State the percentage by volume of oxygen in clean air. [1]  
(ii) Explain how fractional distillation is used to obtain oxygen from the air. [2]  
(b) When acetylene,  $\text{C}_2\text{H}_2$ , burns in oxygen it produces a very hot flame.  
State one industrial use for this oxyacetylene flame. [1]  
(e) Oxygen,  $\text{O}_2$ , in the atmosphere can react to form ozone,  $\text{O}_3$ .  
(i) Write an equation for this reaction. [1]  
(ii) In the **upper** atmosphere there is a layer of ozone surrounding the Earth.  
Explain the importance of this layer in terms of human health [1]

**SOLUTION**

- (a) (i) 20%  
(ii) Purified air is compressed and expanded so it cools down to liquid air. It is then fractionally distilled. The gases with higher boiling points such as nitrogen boil off first leaving behind liquid oxygen.  
(b) For welding/joining metals or for cutting metals  
(e) (i)  $3\text{O}_2 \rightarrow 2\text{O}_3$   
(ii) It absorbs ultraviolet radiation from sunlight which is harmful for human health and also causes skin cancer

**35** [N11/P2/QA3/e]

- (e) Explain why the incomplete combustion of an alkane in an enclosed space is hazardous. [2]

**SOLUTION**

- (e) CO is formed as a result of incomplete combustion which is a poisonous gas (*i. e* CO combines **irreversibly** with haemoglobin **reducing** the oxygen carrying capacity of **haemoglobin**)

**36** [N11/P2/QA4/b,c]

- (b) Coal contains a small amount of sulfur.  
 (i) Explain how the burning of coal results in the formation of acid rain. [3]  
 (ii) State one effect of acid rain. [1]
- (c) Oxides of nitrogen also contribute to acid rain. They can be formed naturally in the atmosphere from nitrogen and oxygen.  
 (i) What condition is needed to allow nitrogen and oxygen to combine in the atmosphere? [1]  
 (ii) Nitric acid in the atmosphere can chemically erode buildings made from carbonate rocks. Write an equation for the reaction of nitric acid,  $\text{HNO}_3$ , with calcium carbonate,  $\text{CaCO}_3$ . [2]

**SOLUTION**

- (b) (i) Burning of coal produces  $\text{CO}_2$  and  $\text{SO}_2$ ;  $\text{S} + \text{O}_2 \rightarrow \text{SO}_2$ .  $\text{SO}_2$  is further oxidised to  $\text{SO}_3$ ;  $2\text{SO}_2 + \text{O}_2 \rightarrow 2\text{SO}_3$ . Thus  $\text{SO}_3$  dissolves in rain water to produce  $\text{H}_2\text{SO}_4$  which results in acid rain  
 (ii) Acid rain creates breathing difficulties and is it is also a lung and throat irritant.
- (c) (i) High voltage produced in lightning is required for nitrogen to react with oxygen in the atmosphere(to break nitrogen tippel bond)  
 (ii)  $2\text{HNO}_3 + \text{CaCO}_3 \rightarrow \text{Ca}(\text{NO}_3)_2 + \text{CO}_2 + \text{H}_2\text{O}$

**37** [N12/P2/QA1/b(v,vi)]

- (b) Choose from the following compounds to answer the questions below.
- |                          |                       |                        |                     |
|--------------------------|-----------------------|------------------------|---------------------|
| <b>calcium carbonate</b> | <b>carbon dioxide</b> | <b>carbon monoxide</b> | <b>ethane</b>       |
| <b>glucose</b>           | <b>methane</b>        | <b>propane</b>         | <b>sodium oxide</b> |
| <b>sucrose</b>           | <b>water</b>          | <b>zinc oxide</b>      |                     |
- Each compound can be used once, more than once or not at all.  
 Which compound  
 (v) is a hydrocarbon formed by the bacterial decay of vegetable matter, [1]  
 (vi) is a product of the incomplete combustion of a hydrocarbon? [1]

**SOLUTION**

- (b) (v)  $\text{CH}_4$   
 (Bacterial decay of vegetable matter produces methane gas)  
 (vi)  $\text{CO}$   
 (Incomplete combustion of hydrocarbon produces  $\text{CO}$  while complete combustion produces  $\text{CO}_2$  and  $\text{H}_2\text{O}$ )

**38** [J13/P2/QA2/a,b]

- Both respiration and combustion add carbon dioxide to the atmosphere.  
 (a) Give one reason why scientists are concerned about the increasing use of fossil fuels. [1]  
 (b) Respiration is a process that occurs in living organisms where glucose,  $\text{C}_6\text{H}_{12}\text{O}_6$ , reacts with oxygen.  
 Write the overall equation that represents respiration. [1]

**SOLUTION**

- (a)  $\text{CO}_2$  is produced which is a greenhouse gas  
 (Other possible answers: Fossil fuels are non-renewable energy resource which may eventually run out and burning of fossil fuels results in global warming and acid rain)
- (b)  $\text{C}_6\text{H}_{12}\text{O}_6 + 6\text{O}_2 \rightarrow 6\text{CO}_2 + 6\text{H}_2\text{O}$



**39** [N13/P2/QA4/a,b]

The carbon cycle regulates the amount of carbon dioxide in the atmosphere.

- (a) (i) State **two** processes which release carbon dioxide into the atmosphere. [2]  
(ii) Name one process which removes carbon dioxide from the atmosphere. [1]
- (b) Carbon dioxide is a greenhouse gas.  
(i) What is the meaning of the term *greenhouse gas*? [1]  
(ii) Name another greenhouse gas and give a natural source of this gas. [2]

**SOLUTION**

- (a) (i) 1. Respiration  
2. Combustion of fossil fuels  
(Other possible answers: Decay of organic matter, decomposition of carbonates, eruption of volcanoes and from the removal of dissolved CO<sub>2</sub> from oceans)
- (ii) Photosynthesis uses CO<sub>2</sub> or it is absorbed by oceans and seas
- (b) (i) Greenhouse gas absorbs infra-red radiation and traps heat  
(ii) Name: Methane  
Source: From swamps  
(Other possible sources: Rice paddy fields, gas from waste from animal digestion, termites and wetlands)

**40** [J14/P2/QA1/b,c]

Choose from the following gases to answer the questions below.

**CCl<sub>3</sub>F**      **CH<sub>4</sub>**      **CO**      **CO<sub>2</sub>**      **H<sub>2</sub>**  
**N<sub>2</sub>**      **NH<sub>3</sub>**      **O<sub>2</sub>**      **SO<sub>2</sub>**

Each gas can be used once, more than once or not at all.

Which gas is

- (b) made by the bacterial decay of vegetable matter, [1]  
(c) responsible for ozone depletion in the upper atmosphere, [1]

**SOLUTION**

- (b) CH<sub>4</sub>  
(c) CCl<sub>3</sub>F<sub>3</sub>  
(CFC's produce chlorine free radicals which react with ozone, removing it from the stratosphere)

**41** [N14/P2/QA4/d]

- (d) Sulfuric acid is one of the acids present in acid rain.  
(i) Suggest how sulfuric acid is formed in the atmosphere. [2]  
(ii) State one effect of acid rain on human health. [1]

**SOLUTION**

- (d) (i) • Fossil fuels containing sulphur burn in air to form sulphur dioxide  
• Sulfur dioxide is oxidised further in atmosphere (to form sulphur trioxide)  
• SO<sub>3</sub> reacts with water vapour to form sulfuric acid.
- (ii) Breathing difficulties  
(Other possible effects: aggravates asthma / irritates respiratory system / irritates nose, mouth or throat)

42

[J15/P2/QA1/a(i)]

Choose from the following compounds to answer the questions opposite.

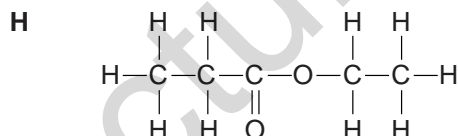
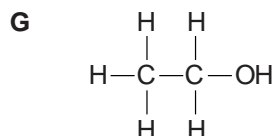
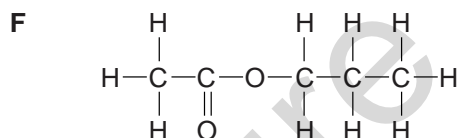
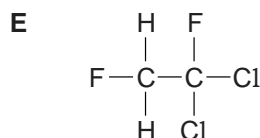
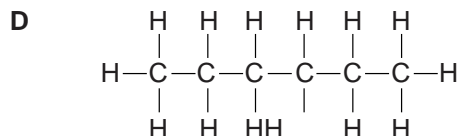
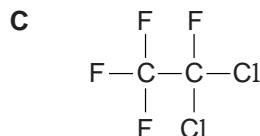
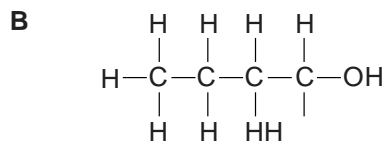
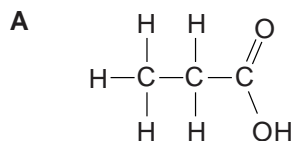

Each compound can be used once, more than once or not at all.

- (a) Give the letter of the compound which  
(i) is a CFC,

[1]

**SOLUTION**

- (a) (i) **C** (CFC is a compound containing carbon, chlorine and fluorine)

43

[J16/P2/QA6/b,c,d]

River water contains dissolved minerals and gases.

- (b) River water often contains dissolved compounds such as ammonium nitrate and calcium phosphate.  
(i) State **one** source of both of these compounds. [1]  
(ii) Describe and explain the environmental effect of the presence of these dissolved compounds in river water. [3]
- (c) River water is often purified for use as drinking water.  
Describe **three** processes involved in the purification of river water. [3]
- (d) Water has a low melting point and is neutral (pH = 7).  
(i) Explain why water has a low melting point. [1]  
(ii) A pH meter can be used to confirm that water is neutral.  
Describe another way in which a student can confirm that water is neutral. [1]

**SOLUTION**

- (b) (i) Fertilisers

- (ii) The presence of such dissolved compounds in the river water promotes the growth of algae on the surface, as the algal bloom grows, it blocks the sunlight reaching to the aquatic life. Plants beneath the surface die due to the lack of photosynthesis and are decomposed by oxygen consuming microorganisms. This leads to the deficiency of oxygen for other aquatic life that eventually dies too. The process is known as eutrophication
- (c) process 1: Chlorination: this kills bacteria or microbes  
process 2: Filtration: this removes large, insoluble materials  
process 3: Purification with Carbon: carbon helps to remove odour and unpleasant tastes  
*(sedimentation also allows small insoluble particles to settle out)*
- (d) (i) Water has a simple molecular structure and weak intermolecular forces  
(ii) The student can add universal indicator to the water which turns green when neutral

Mega Lecture

## UNIT-11

## ORGANIC CHEMISTRY

### 11.1 Alkanes

**1** [J05/P2/QA4]

Petroleum is a mixture of hydrocarbons. In an oil refinery it is separated into fractions by fractional distillation.

The diagram shows a fractionating column and some of the fractions obtained from petroleum.

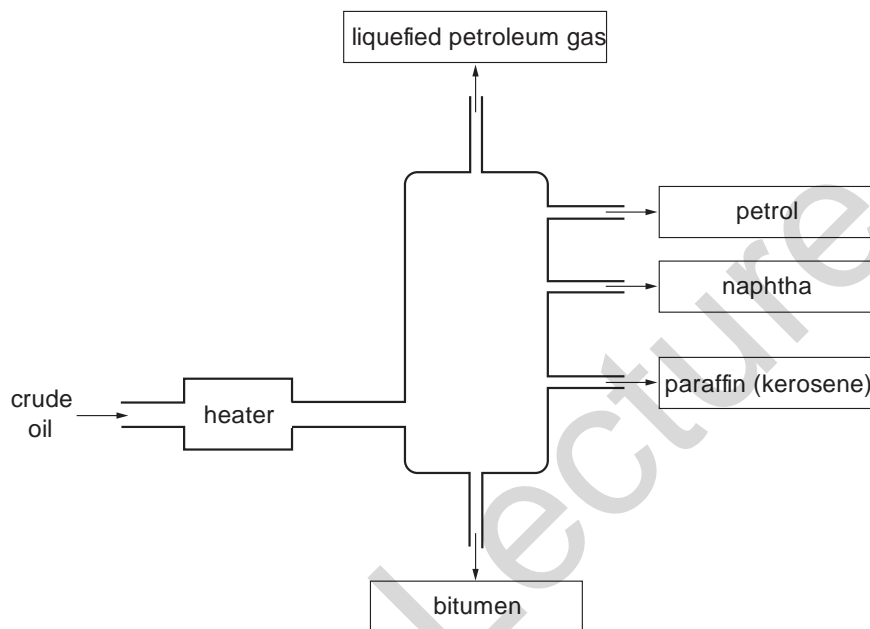

- (a) State the physical property on which the separation depends. [1]
- (b) (i) State **one** use for the naphtha fraction.  
(ii) State **one** use for the bitumen fraction. [2]
- (c) The liquefied petroleum gas fraction contains the saturated hydrocarbons methane,  $\text{CH}_4$ , and ethane,  $\text{C}_2\text{H}_6$ .  
(i) What is the meaning of the term *saturated hydrocarbon*?  
(ii) Draw a 'dot and cross' diagram to show the bonding in methane. You only need to draw the outer electrons of carbon. [4]
- (d) Describe the importance of cracking in the oil refining process. [2]

#### SOLUTION

- (a) Boiling point  
(Distillation process depends on change of liquid to vapour and vapour to condense, that is why boiling point is important to carry out this process)
- (b) (i) 1. Making chemicals or petrol by cracking  
(Alternative answer: making feedstock)  
(ii) Used for carpeting roads.

- (c) (i) The hydrocarbons in which all the bonds between carbon atoms are singly bonded.  
(ii)

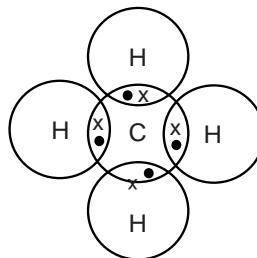

- (d) Cracking is done to break bigger hydrocarbons into smaller and useful hydrocarbons such as petrol and ethane.

2

[J06/P2/QA3]

The structures shown below are of the first two members of an homologous series known as the cyclopropanes.

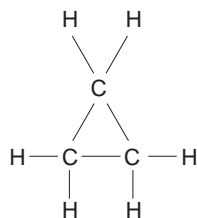

compound D

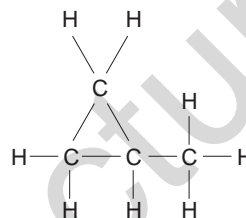

compound E

Members of an homologous series have a general formula.

- (a) (i) State **one other** characteristic of an homologous series. [1]  
(ii) Deduce the general formula for the cyclopropane homologous series. [1]  
(b) Cyclopropanes react in a similar way to alkanes such as methane.  
(i) Write a chemical equation for the complete combustion of compound D. [2]  
(ii) Suggest the **type** of reaction by which compound D reacts with chlorine. [1]  
(c) Name and draw the structure of an alkene that is an isomer of compound D. [2]  
name structure

### SOLUTION

- (a) (i) Members of the same homologous series have same chemical reactions  
(Other characteristics: gradation in physical properties/differ by  $-CH_2-$  group/have same functional group)  
(ii)  $C_nH_{2n}$   
(The number of hydrogen atoms present is double the number of carbon atoms present)  
(b) (i)  $2C_3H_6 + 9O_2 \rightarrow 6CO_2 + 6H_2O$ .  
(ii) Substitution reaction  
(Compound D reacts with chlorine by substitution reactions only since it contains all carbon-carbon single covalent bonds.)  
(c) Propene/Propylene

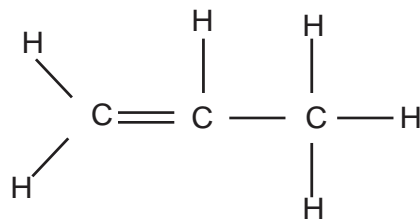

(Isomers have the same general formula,  $C_nH_{2n}$ , in this case)

**3**

[J07/P2/QA1/b]

Choose from the following oxides to answer the questions below.

aluminium oxide

calcium oxide

carbon monoxide

copper(II) oxide

sulphur dioxide

sulphur trioxide

vanadium(V) oxide

Each oxide can be used once, more than once or not at all.

Name an oxide which

(b) is formed during the incomplete combustion of propane,

[1]

**SOLUTION**

(b) Carbon monoxide

(CO is produced as a result of incomplete combustion of hydrocarbons)

**4**

[J07/P2/QA4/a]

Structures of six organic compounds are shown.

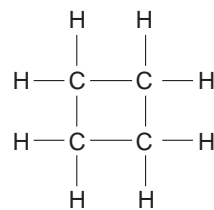

compound A

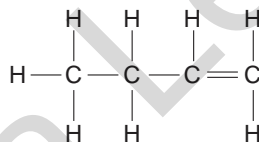

compound B

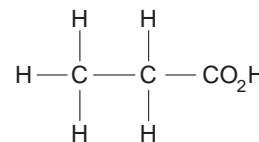

compound C

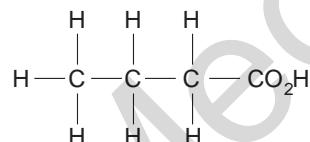

compound D

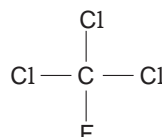

compound E

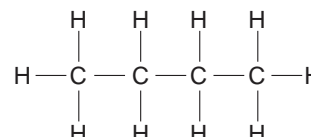

compound F

(a) Which **two** compounds have the same molecular formula?

[1]

**SOLUTION**

(a) A and B

(A and B have same molecular formula i.e.  $C_4H_8$ )

**5** [J07/P2/QB11/c(iii)]

- (c) (iii) Explain why ethanol made from ethane is a non-renewable fuel but that made from glucose is a renewable fuel. [2]

**SOLUTION**

- (c) (iii) Ethene is obtained from crude oil, which is a finite source (non renewable)  
Glucose is obtained from plants which is a renewable source. That is why ethanol made from glucose is said to be a renewable fuel.

**6** [N07/P2/QA1/a,d]

Choose from the following gases to answer the questions below.

**Ammonia**      **butane**      **carbon dioxide**      **carbon monoxide**  
**Hydrogen**      **methane**      **nitrogen**      **nitrogen dioxide**      **oxygen**

Each gas can be used once, more than once or not at all.

Which gas is

- (a) the main constituent of natural gas, [1]  
(d) a product of the incomplete combustion of hydrocarbons, [1]

**SOLUTION**

- (a) Methane  
(d) Carbon monoxide  
(Incomplete combustion produces carbon monoxide while complete combustion produces carbon dioxide and water)

**7** [N07/P2/QA3/b(i,ii)]

- (b) Germanium, Ge, is an element in Group IV of the Periodic Table. Some of its chemistry resembles that of carbon.  
(i) Predict the general molecular formula for these compounds. [1]  
(ii) Germanoethane, Ge<sub>2</sub>H<sub>6</sub>, has a similar structure to ethane. Draw the full structural formula for germanoethane. [1]

**SOLUTION**

- (b) (i) Ge<sub>n</sub>H<sub>2n+2</sub>  
(General formula for alkanes = C<sub>n</sub>H<sub>2n+2</sub>)  
(ii)

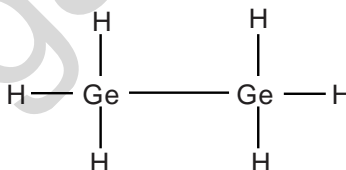

**8** [J08/P2/QA1/a]

Choose from the following gases to answer the questions below.

**Ammonia**      **argon**      **carbon monoxide**  
**Chlorine**      **hydrogen**      **nitrogen**  
**nitrogen dioxide**      **oxygen**

Each gas can be used once, more than once or not at all.

Name a gas which

- (a) is made during the incomplete combustion of octane, [1]

**SOLUTION**

- (a) Carbon monoxide  
(Incomplete combustion of hydrocarbons always produces carbon monoxide)

**9 [J08/P2/QA4/c]**

- (c) Ethane reacts with chlorine in the presence of ultra-violet light.  
Suggest a structure for a product of this reaction. [1]

**SOLUTION**

(c)

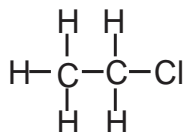

(Any substituent product from  $\text{C}_2\text{H}_4\text{Cl}_2$  to  $\text{C}_2\text{Cl}_6$  can be shown with correct displayed formula)

**10 [J08/P2/QA5/d]**

- (d) Finally the wax on the match head begins to combust.  
One compound in the wax has the formula  $\text{C}_{18}\text{H}_{38}$ .  
To which class of hydrocarbons does this compound belong? Explain your answer. [1]

**SOLUTION**

- (d) It belongs to alkanes. The general formula for alkanes is  $\text{C}_n\text{H}_{2n+2}$  and  $\text{C}_{18}\text{H}_{38}$  fits in the formula

**11 [J08/P2/QB8/a]**

Crude oil is a raw material which is processed in an oil refinery.

Two of the processes used are fractional distillation and cracking.

The table shows the percentage by mass of some different fractions in crude oil. The table also shows the demand for each fraction expressed as a percentage.

| fraction          | number of carbon atoms per molecule | percentage in crude oil | percentage needed by the oil refinery to supply demand |
|-------------------|-------------------------------------|-------------------------|--|
| petroleum gases   | 1 – 4                               | 4%                      | 11%  |
| gasoline          | 5 – 9                               | 11%                     | 22%  |
| kerosene          | 10 – 14                             | 12%                     | 20%  |
| gas oil           | 14 – 20                             | 18%                     | 15%  |
| waxes and bitumen | over 20                             | 23%                     | 4%   |

- (a) The variation in which physical property is used to separate crude oil by fractional distillation? [1]

**SOLUTION**

- (a) Boiling point



12

[N03/P2/QA6/b]

- (b) Chlorine is used to make chloroethene.

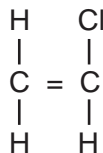

Chloroethene can be polymerised to form poly(chloroethene).  
Draw a section of a poly(chloroethene) chain to show at least two repeating units.

[1]

**SOLUTION**

- (b)

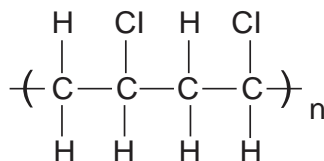

13

[J09/P2/QB8/a]

Petrol (gasoline) is a mixture of hydrocarbons, one of which is octane, C<sub>8</sub>H<sub>18</sub>.

- (a) Describe briefly how petrol is obtained from crude oil.

[2]

**SOLUTION**

- (a) Petrol is separated from crude oil by fractional distillation of crude oil or by cracking of long chain hydrocarbons and then separating them by fractional distillation. This process is possible because fractions of crude oil have different boiling points

14

[J09/P2/QB9/a]

Alcohols are an homologous series of organic chemical compounds.  
The table shows some information about different alcohols.

| alcohol  | formula                           | boiling point / °C |
|----------|-----------------------------------|--------------------|
| methanol | CH <sub>3</sub> OH                | 65                 |
| ethanol  | C <sub>2</sub> H <sub>5</sub> OH  | 78                 |
| propanol | C <sub>3</sub> H <sub>7</sub> OH  | 97                 |
| pentanol | C <sub>5</sub> H <sub>11</sub> OH | 138                |

- (a) What is meant by the term *homologous series*?

[3]

**SOLUTION**

- (a) Homologous series have a general formula with the same functional group. Each successive member of the series differs by CH<sub>2</sub> group. They have similar chemical properties.

15

[J11/P2/QA2]

Alkanes are a homologous series of saturated hydrocarbons.

- (a) What is the general formula of alkanes?

[1]

- (b) Draw the structures of the two isomers of  $C_4H_{10}$  [2]  
 (c) One of the isomers of  $C_4H_{10}$ , butane, reacts with chlorine in the presence of ultra-violet light. It forms hydrogen chloride gas and a mixture of liquid compounds.  
 (i) Name this type of reaction. [1]  
 (ii) Draw the structure of one of the liquid compounds. [1]  
 (d) Name the process by which butane is separated from crude oil. [1]

**SOLUTION**

(a)  $C_n H_{2n+2}$

(b)

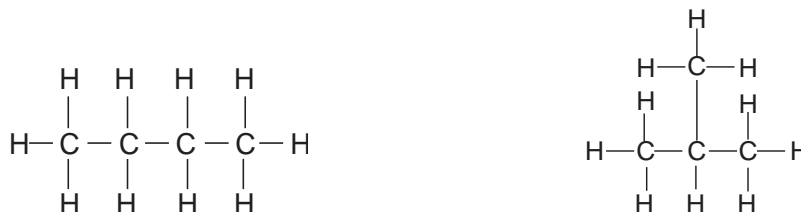

Isomers are molecules that have the **same molecular formula**, but have a **different arrangement** of the atoms in space

- (i) Substitution reaction  
 (ii)

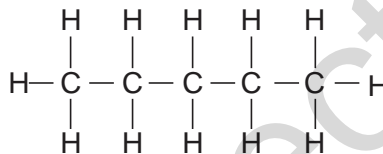

Butane gives **substitution** reaction with chlorine to produce **HCl** and **chlorobutane**

(c) Fractional distillation

**16**

**[N11/P2/QA3/a,b,c]**

The alkanes are an homologous series of saturated hydrocarbons with the general formula  $C_n H_{2n+2}$ .

- (a) What do you understand by the term *hydrocarbon*? [1]  
 (b) Write the molecular formula for the alkane containing seven carbon atoms. [1]  
 (c) Two different structural formulae can be written for the alkane having the molecular formula  $C_4H_{10}$ .

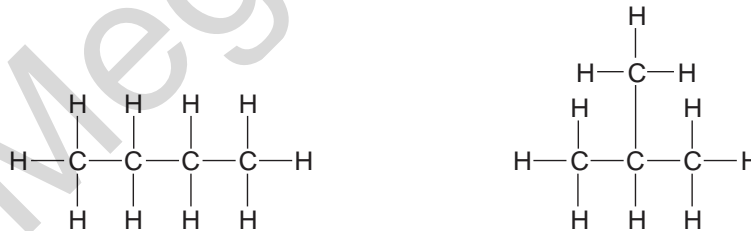

butane

methylpropane

What term is given to compounds with the same molecular formula but different structural formulae?

[1]

**SOLUTION**

- (a) Hydrocarbons are substances containing atoms of carbon and hydrogen only  
 (b)  $C_7H_{16}$   
 The general formula of alkanes is  $C_nH_{2n+2}$   
 For heptanes,  $n = 7$   
 (c) Isomers

**17**

**[J13/P2/QA4]**

The structures of some of the compounds that can be manufactured from crude oil are shown.

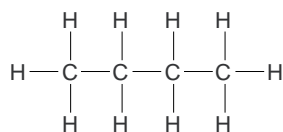

butane

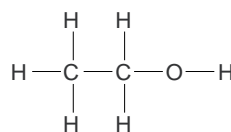

ethanol

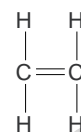

ethene

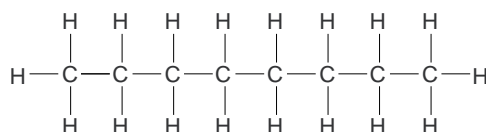

octane

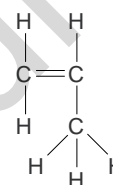

propene

- (a) Octane is found in the petrol fraction separated from crude oil.  
 Name the process by which petrol is separated from crude oil and state the physical property which allows this process to be carried out. [2]  
 (b) Hexadecane,  $C_{16}H_{34}$ , can be cracked to produce a mixture of alkanes and alkenes.  
 Construct an equation to show the cracking of hexadecane to produce octane. [2]  
 (c) Propene can be polymerised to make poly(propene).  
 Draw a section of the structure of poly(propene). [2]  
 (d) Ethanol is manufactured by a hydration reaction.  
 State both the reagents and conditions for this reaction. [2]

**SOLUTION**

- (a) They are separated by fractional distillation on the basis of their boiling points.  
 (b)  $C_{16}H_{34} \rightarrow C_8H_{18} + C_8H_{16}$   
 (Other possible equations:  $C_{16}H_{34} \rightarrow C_8H_{18} + 2C_4H_8$ ;  $C_{16}H_{34} \rightarrow C_8H_{18} + 4C_2H_4$ ;  $C_{16}H_{34} \rightarrow C_8H_{18} + C_4H_8 + 2C_2H_4$ )  
 (c)

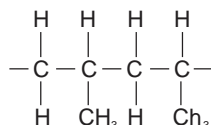

Polypropylene  
(PP)

- (d) **Reagents:** Ethene and steam  
**Conditions:** Heat and Catalyst ( $\text{H}_3\text{PO}_4$ ), temp-(270-300 °C) and at a pressure of 270 atm.

**18** [J14/P2/QA1/d]

- (d) used to manufacture margarine? [1]

**SOLUTION**

- (d)  $\text{H}_2$   
(Margarine is produced by hydrogenation of alkenes)

**11.2 Alkenes**

**19** [N05/P2/QA7]

An oil refinery uses two different processes, **Process 1** and **Process 2**, to crack naphtha. The table below shows some information about the percentage yields of products from each process.

| Product                                   | yield / % |           |
|---|-----------|-----------|
|   | Process 1 | Process 2 |
| Hydrogen                                  | 1         | 1         |
| Methane                                   | 18        | 14        |
| Ethane                                    | 32        | 20        |
| Propene                                   | 13        | 15        |
| $\text{C}_4$ hydrocarbons                 | 9         | 10        |
| $\text{C}_5$ to $\text{C}_8$ hydrocarbons | 27        | 40        |

The refinery sells ethene and  $\text{C}_5$  to  $\text{C}_8$  hydrocarbons. Ethene is used to make addition polymers, and  $\text{C}_5$  to  $\text{C}_8$  hydrocarbons are added to petrol. Use the information given to explain why the refinery must use **both** processes to meet the high demand for both ethene and  $\text{C}_5$  to  $\text{C}_8$  hydrocarbons. [2]

**SOLUTION**

Process 1 gives a higher yield of ethene whereas process 2 has higher yields of  $\text{C}_5$  to  $\text{C}_8$  hydrocarbons

**20** [J06/P2/QB11/c(iii)]

- (c) (iii) Describe what you would observe when bromine reacts with chloroethene and state what type of reaction takes place.  
Explain why bromine will **not** readily react with poly(chloroethene). [3]

**SOLUTION**

- (c) (iii) Bromine decolorizes and addition reaction takes place  
Polychloroethene does not decolorize bromine because there are no double bonds present in polychloroethene.

**21** [N06/P2/QA2/b]

- (b) Petroleum fractions need to be cracked.  
(i) Why do oil companies need to crack petroleum fractions? [1]  
(ii) State the conditions needed for cracking. [2]

- (iii) Complete the following equation for the cracking of tetradecane.  
 $C_{14}H_{30} \rightarrow C_{10}H_{22} + \dots\dots\dots$  [1]

**SOLUTION**

- (b) (i) Oil companies crack petroleum fractions to produce more of the useful fractions (in demand by chemical industries).  
 (To produce more petrol, to produce alkenes with higher demands, to produce smaller molecules and to produce plastics)
- (ii) High temperature about 500 °C and aluminium oxide as a catalyst.
- (iii)  $C_{14}H_{30} \rightarrow C_{10}H_{22} + C_4H_8$ .

**22 [N07/P2/QB7/d]**

- (d) Nickel is used in the manufacture of margarine to catalyse the reduction of unsaturated vegetable oils to saturated oils.
- (i) What do you understand by the following terms?  
 • catalyst [2]  
 • unsaturated
- (ii) What other reactant is needed to convert an unsaturated oil into a saturated oil? [1]

**SOLUTION**

- (d) (i) **Catalyst** A chemical substance which speed up the chemical reactions by lowering the activation energy of the reaction and remain chemically unchanged at the end of the reaction.
- (ii) **Unsaturated:** Any compound having multiple bond between carbon atoms  
 Hydrogen gas

**23 [J08/P2/QA4/a,d]**

Ethane,  $C_2H_6$ , and ethene,  $C_2H_4$ , are both gaseous hydrocarbons.

- (a) Describe how aqueous bromine can be used to distinguish between a sample of ethane and a sample of ethene. [2]
- (d) Write both the name and the molecular formula of an alkene molecule containing four carbon atoms. [2]  
 name molecular formula

**SOLUTION**

- (a) With ethane gas, the brown color of bromine does not change, but with ethene, bromine changes its color from brown to colorless  
 (Ethane is a saturated hydrocarbon and hence does not react with bromine whereas ethene being unsaturated undergoes addition reaction with bromine causing its color to disappear)
- (d) Butene  
 $C_4H_8$   
 (General formula of alkenes =  $C_nH_{2n}$ )

**24 [J08/P2/QB8/b,c,d]**

Crude oil is a raw material which is processed in an oil refinery.  
 Two of the processes used are fractional distillation and cracking.  
 The table shows the percentage by mass of some different fractions in crude oil. The table also shows the demand for each fraction expressed as a percentage.

| fraction          | number of carbon atoms per molecule | percentage in crude oil | percentage needed by the oil refinery to supply demand |
|-------------------|-------------------------------------|-------------------------|--|
| petroleum gases   | 1 – 4                               | 4%                      | 11%  |
| gasoline          | 5 – 9                               | 11%                     | 22%  |
| kerosene          | 10 – 14                             | 12%                     | 20%  |
| gas oil           | 14 – 20                             | 18%                     | 15%  |
| waxes and bitumen | over 20                             | 23%                     | 4%   |

- (b) (i) Define the term *cracking*. [2]  
 (ii) Use information from the table to explain how cracking helps an oil refinery match the supply of gasoline with the demand for gasoline. [2]
- (c) The hydrocarbon  $C_{15}H_{32}$  can be cracked to make propene and one other hydrocarbon.  
 (i) Draw the structure of propene. [1]  
 (ii) Write an equation for this reaction. [1]
- (d) Propene is used to make alcohols and poly(propene).  
 (i) Describe how propene can be converted into an alcohol and draw the structure of this alcohol. [2]  
 (ii) Draw the structure of poly(propene) showing at least two repeat units. [1]

**SOLUTION**

- (b) (i) Breaking of long chain hydrocarbons into smaller chains by using high temperature and catalyst  
 (ii) Wax having more than 20 carbon atoms in its molecule are less needed (less demand in the chemical industries) and hence are cracked into smaller chain hydrocarbons which can be used as much needed fuel like kerosene and gasoline
- (c) (i)  $CH_3CH=CH_2$   
 (ii)  $C_{15}H_{32} \rightarrow C_3H_6 + C_{12}H_{26}$
- (d) (i) Propene is reacted with steam in the presence of phosphoric acid acting as a catalyst to produce Propanol

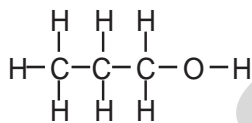

(ii)

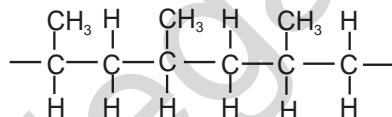

**25**

**[N08/P2/QB8/b(ii)]**

- (b) Sorrel plants contain a poisonous carboxylic acid **X**.  
 What can be deduced about **X** from each of the following three pieces of information?  
 (ii) Aqueous bromine is not decolourised when added to a solution of **X**. [1]

**SOLUTION**

- (b) (ii) No change in color of aqueous bromine indicates that double bond is absent (If double bond is present in a compound, it undergoes addition reaction with aqueous bromine and causes bromine to change its color).

**26** [N09/P2/QA1/a(i)]

- (a) Choose from the following compounds to answer the questions below.  
**ammonium sulfate**      **calcium oxide**      **copper(II) chloride**      **ethanoic acid**  
**ethane**      **nitrogen dioxide**      **sodium iodide**      **sulfur dioxide**
- Each compound can be used once, more than once or not at all.  
 Which compound  
 (i) may be formed when alkanes are cracked, [1]

**SOLUTION**

- (a) (i) Ethene  
 (On cracking, alkanes produce alkanes, alkenes or hydrogen)

**27** [N09/P2/QB8/a]

Fumaric acid is a colourless solid which can be extracted from plants.

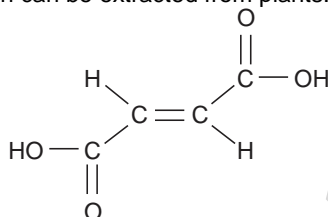

- (a) Describe the reaction of aqueous fumaric acid with aqueous bromine, giving the equation for the reaction and stating any observations. [3]

**SOLUTION**

- (a) When fumaric acid is added to bromine, brown color of bromine decolourises  

$$\text{C}_4\text{H}_4\text{O}_4 + \text{Br}_2 \rightarrow \text{C}_4\text{H}_4\text{O}_4 \text{Br}_2$$

**28** [J10/P2/QA1/f]

Choose from the following compounds to answer the questions below.

**BaSO<sub>4</sub>**      **CH<sub>4</sub>**      **C<sub>2</sub>H<sub>4</sub>**      **C<sub>3</sub>H<sub>8</sub>**      **CO<sub>2</sub>**  
**CaCO<sub>3</sub>**      **CF<sub>3</sub>Cl**      **K<sub>2</sub>Cr<sub>2</sub>O<sub>7</sub>**      **MgSO<sub>4</sub>**      **NaCl**      **ZnSO<sub>4</sub>**

Each compound can be used once, more than once or not at all.

Which compound

- (f) decolourises aqueous bromine? [1]

**SOLUTION**

- (f) C<sub>2</sub>H<sub>4</sub>  
*Unsaturated hydrocarbons (alkenes) react with Br<sub>2(aq)</sub> changing its color from brown to colorless.*  

$$\text{C}_2\text{H}_4 + \text{Br}_2 \rightarrow \text{C}_2\text{H}_4\text{Br}_2$$

**29** [J10/P2/QA5/a,b]

Ethanol, C<sub>2</sub>H<sub>5</sub>OH, can be manufactured by two different processes.

- process1 – the catalysed addition of steam to ethene
- process2 – the fermentation of glucose

- (a) Name the type of reaction used to manufacture **ethene**. [1]

- (b) (i) Write the equation for process 1. [1]  
(ii) Suggest the name of the alcohol made when the alkene  $C_3H_6$  reacts with steam in the presence of a catalyst. [1]

**SOLUTION**

- (a) Cracking  
(b) (i)  $C_2H_4 + H_2O \rightarrow C_2H_5OH$   
Alkenes react with water at  $300^\circ C$ , 60atm and in presence of  $H_3PO_4$  to form alcohols  
(ii) Propanol

**30**

**[J11/P2/QA3/a,b,c]**

Vegetable oils can be used both to make margarine and as fuels such as bio-diesel.

- (a) Many vegetable oils are polyunsaturated.  
(i) Explain the meaning of the term *polyunsaturated*. [2]  
(ii) Describe how you could distinguish between samples of saturated and unsaturated vegetable oils. [2]  
(b) Describe how margarine can be manufactured from unsaturated vegetable oils. [1]  
(c) Bio-diesel contains the compound  $C_{15}H_{30}O_2$ .  
Suggest the products of the complete combustion of this compound. [2]

**SOLUTION**

- (a) (i) Hydrocarbons having many carbon-carbon double bonds  
**Polyunsaturated** means having **more than one** double bond  
(ii) Add aqueous bromine to both samples. Saturated hydrocarbon does not decolourise bromine but unsaturated hydrocarbon decolourises bromine  
**Unsaturated** hydrocarbon also **decolourises  $KMnO_4$**  solution while saturated hydrocarbon does not  
(b) By hydrogenating it  
reaction with **hydrogen and nickel as a catalyst**  
(c)  $CO_2$  and  $H_2O$   
**Complete combustion** of hydrocarbons produces  **$CO_2$  and  $H_2O$**

**31**

**[J12/P2/QB8]**

Alkenes are a homologous series of organic compounds.

The table shows some information about the first six alkenes.

| name    | molecular formula | melting point / $^\circ C$ | boiling point / $^\circ C$ |
|---------|-------------------|----------------------------|----------------------------|
| ethene  | $C_2H_4$          | -169                       | -104                       |
| propene | $C_3H_6$          | -185                       | -48                        |
| butene  | $C_4H_8$          | -185                       | -6                         |
| pentene | $C_5H_{10}$       | -165                       | 30                         |
| hexene  | $C_6H_{12}$       | -139                       | 63                         |
| heptene | $C_7H_{14}$       |                            |                            |

- (a) Draw the structure, showing all the atoms and bonds, of propene.  
Use the structure to explain why propene is both a *hydrocarbon* and *unsaturated*. [3]  
(b) There are several compounds with molecular formula  $C_4H_8$ , each has a different structure.  
What name is given to compounds with the same molecular formula but different structures? [1]



- (c) Deduce the molecular formula for decene, an alkene with 10 carbon atoms per molecule. [1]  
 (d) Explain why it is easier to predict the boiling point of heptene rather than its melting point. [1]  
 (e) What is the physical state for butene at room temperature and pressure? Explain your answer.  
 physical state [1]  
 explanation  
 (f) Many alkenes are manufactured by the cracking of long chain alkanes such as hexadecane,  $C_{16}H_{34}$ .  
 Construct an equation to show the cracking of hexadecane to form butane and butene only. [1]  
 (g) Butene reacts with bromine and with steam.  
 (i) Give the molecular formula of the product with bromine [1]  
 (ii) Suggest the name of the product with steam. [1]

**SOLUTION**

(a)

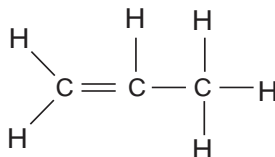

- (b) Propene is a hydrocarbon because it contains atoms of hydrogen and carbon only and also it is unsaturated because it contains carbon-carbon double bond.  
 (c) Isomer  
 (d)  $C_{10}H_{20}$   
 (General formula for alkenes is  $C_nH_{2n}$ )  
 (f) Melting point trend is irregular down the series while boiling point is increasing regularly. Therefore it is easier to predict the boiling point of heptene.  
 Butene is gas at r.t.p because its boiling point is lower than the room temperature  
 $C_{16}H_{34} \rightarrow 3C_4H_8 + C_4H_{10}$   
 (g) (i)  $C_4H_8Br_2$   
 (Alkenes react with bromine to form dibromobutane and with steam to produce alcohols)  
 (ii) Butanol  
 (Can be written as: Butan-1-ol/Butan-2-ol)

**32**

[J13/P2/QA3/d]

- (d) Describe how bromine is used to test for unsaturation in organic compounds. [1]

**SOLUTION**

- (d) Unsaturated compounds decolourise aqueous bromine.

**33**

[N13/P2/QB7/a,b,c]

Ethene is an unsaturated hydrocarbon.

- (a) What is the meaning of each of these terms?  
*Unsaturated, hydrocarbon* [2]  
 (b) Ethene can be manufactured by cracking.  
 (i) State the conditions used for cracking. [2]  
 (ii) Construct an equation for the cracking of tetradecane,  $C_{14}H_{30}$ , to form ethane and one other hydrocarbon. [1]

**SOLUTION**

- (a) Unsaturated refers to the presence of carbon carbon double bond  
Hydrocarbon refers to a substance containing carbon and hydrogen atoms only.
- (b) (i) High temperature of about 450°C and use of a catalyst (aluminium oxide)  
(ii)  $C_{14}H_{30} \rightarrow C_2H_4 + C_{12}H_{26}$

**34**

**[J14/P2/QB7/a,b,c,d(i,iii)]**

Alkanes are a homologous series of hydrocarbons.

- (a) There are two alkanes with the molecular formula  $C_4H_{10}$ .  
Draw the structures, showing all the atoms and all the bonds, of these two alkanes. [2]
- (b) One of the alkanes with the molecular formula  $C_4H_{10}$  is butane.  
Butane is used as a fuel.  
(i) Construct the equation for the **complete** combustion of butane. [1]  
(ii) Describe one problem associated with the **incomplete** combustion of butane. [1]
- (c) Butane reacts with chlorine in the presence of ultraviolet radiation.  
Write an equation for this reaction. [1]
- (d) (i) Name this type of reaction. [1]  
(iii) Suggest a molecular formula for H. [1]

**SOLUTION**

(a)

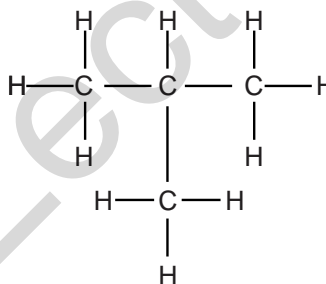
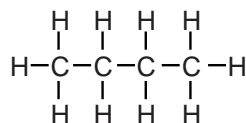

- (b) (i)  $2C_4H_{10} + 13O_2 \rightarrow 8CO_2 + 10H_2O$ .  
(ii) CO is produced which is a poisonous gas
- (c)  $C_4H_{10} + Cl_2 \rightarrow C_4H_9Cl + HCl$ .
- (d) (i) Cracking  
(iii)  $C_2H_4$   
( $C_9H_{20} \rightarrow C_7H_{16} + C_2H_4$ .)

**35**

**[J15/P2/QB8]**

The flow chart shows the steps involved in the manufacture of poly (propenenitrile).

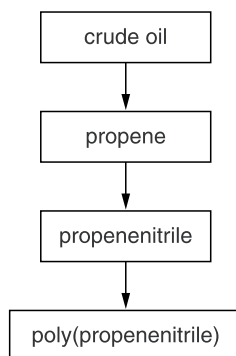

- (a) Long chain alkanes such as  $C_{17}H_{36}$  can be cracked to form propene,  $C_3H_6$ .  
Construct an equation to show the cracking of  $C_{17}H_{36}$  to form propene. [1]
- (b) The equation shows the reaction to make propenenitrile.  
 $2C_3H_6(g) + 2NH_3(g) + 3O_2(g) \rightarrow 2C_3H_3N(g) + 6H_2O(g)$
- (c) Describe and explain what happens to the rate of this reaction if the temperature is increased. [2]  
The structure of propenenitrile is shown.
- $$\begin{array}{c}
 H \quad H \\
 \diagdown \quad / \\
 C = C \\
 / \quad \diagdown \\
 H \quad C \equiv N
 \end{array}$$
- (i) Explain why propenenitrile is unsaturated. [1]  
(ii) Describe a chemical test to show that propenenitrile is unsaturated. [2]
- (d) Draw part of the structure of poly(propenenitrile). [2]
- (e) A factory uses 1750 tonnes of propenenitrile to produce poly(propenenitrile).  
The percentage yield is 95%.  
Calculate the mass of poly(propenenitrile) produced.  
mass of poly(propenenitrile) = tones [2]

### SOLUTION

- (a)  $C_{17}H_{36} \rightarrow C_3H_6 + C_{14}H_{30}$ .
- (b) Increasing the temperature increases the rate of reaction because particles gain kinetic energy and start moving faster resulting in more number of effective collisions. More of the particles have energetic collisions.
- (c) (i) Unsaturation refers to the presence of  $C=C$   
(ii) Chemical test for unsaturation: add aqueous bromine to the sample, sample turns aq. Bromine colorless ( $C=C$  bond in propenenitrile breaks and the compound reacts with aq. Bromine)
- (d)
- $$\begin{array}{c}
 H \quad CN \\
 | \quad | \\
 -C - C- \\
 | \quad | \\
 H \quad H
 \end{array}$$
- (e)  $95 / 100 \times 1750 = 1662.5$

36

[J15/P2/QB9]

Alkenes are a homologous series of unsaturated hydrocarbons.  
The table shows information about some alkenes.

| alkene   | molecular formula               | melting point / °C | boiling point / °C |
|----------|---------------------------------|--------------------|--------------------|
| ethene   | C <sub>2</sub> H <sub>4</sub>   | -169               | -105               |
| butene   | C <sub>4</sub> H <sub>8</sub>   | -185               | -6                 |
| hexene   | C <sub>6</sub> H <sub>12</sub>  | -140               | 63                 |
| decene   | C <sub>10</sub> H <sub>20</sub> | -66                | 171                |
| dodecene | C <sub>12</sub> H <sub>24</sub> | -35                | 214                |

- (a) Decene is a liquid at 25 °C.  
How can you make this deduction from the data in the table? [2]
- (b) Butene boils at -6 °C.  
Use the kinetic particle theory to explain what happens when butene boils. [2]
- (c) A sample of ethene gas in a gas syringe is heated from 20 °C to 100 °C.  
The pressure remains constant.  
Describe and explain, in terms of the kinetic particle theory, what happens to the volume of the gas. [2]
- (d) At room temperature ethene diffuses faster than butene.  
Explain why. [1]
- (e) Draw the structure, showing all the atoms and all the bonds, for two isomers with the molecular formula C<sub>4</sub>H<sub>8</sub>. [2]
- (f) The structure of hexene is shown.

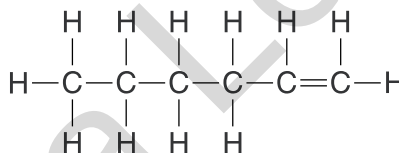

Draw the structure, showing all the atoms and all the bonds, for the product of the reaction of hexene with steam. [1]

### SOLUTION

- (a) Melting point of liquids is below 25°C while boiling point is above 25°C
- (b) As butene boils, the particles gain heat energy and convert it to kinetic energy. They start moving faster and spread out further away from each other, moving in random directions
- (c) The heat energy causes the gas particles to spread out hence the gas expands increasing its volume
- (d) Rate of diffusion increases for gases with lower molecular masses. Ethene has lower Mr than Butene

(e)

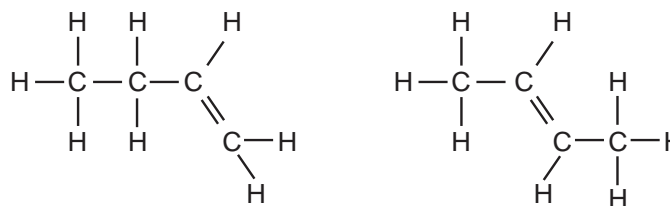

(f)

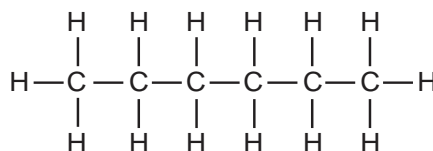

Or draw second structure when OH is present on first carbon atom of R H S)

37

[N15/P2/QB9]

When rubber is heated in the absence of air, a small amount of isoprene is formed. The structure of isoprene is shown.

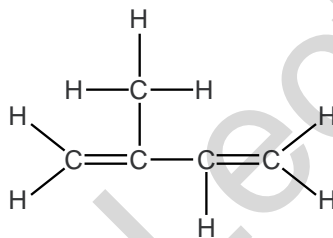

- (a) Isoprene is an unsaturated hydrocarbon.  
Describe a test for an unsaturated hydrocarbon. [2]
- (b) Isoprene is a liquid at 25 °C.  
Describe the arrangement and motion of the particles in isoprene at 25 °C. [2]
- (c) Isoprene reacts with sulfur dioxide to form methylsulfolene.

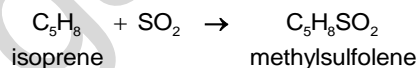

Calculate the maximum mass of methylsulfolene that can be formed from 100 g of isoprene.

Mass of methylsulfolene = g [3]

- (d) (i) What feature of the isoprene molecule is responsible for it forming an addition polymer? [1]  
(ii) Perspex is also an addition polymer.  
The diagram shows part of the polymer chain of Perspex.

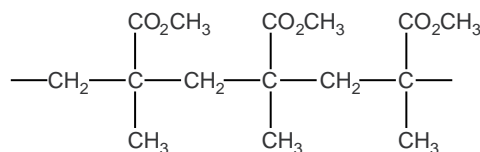

Deduce the formula of the monomer used to make *Perspex*.

[2]

**SOLUTION**

- (a) Reagent: Aq. Bromine  
Test: Unsaturated hydrocarbon decolorizes aq.bromine
- (b) Arrangement: No fixed arrangement, random/irregular shape  
Motion: Particles slide over each other
- (c) Moles of isopropene =  $100/68 = 1.47$  mol (*Moles = mass/Mr*)  
Molar ratio = 1:1  
Therefore, moles of methylsulfolene = 1.47 mol  
mass of methylsulfolene =  $1.47 \times 132 = 194.1$  g
- (d) (i) Carbon-carbon double bond (C=C)  
(ii)

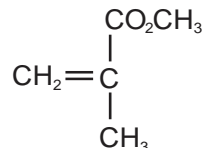

**38**

[J16/P22/QB8/a,b,c,eii]

Cyclohexene,  $\text{C}_6\text{H}_{10}$ , is a cycloalkene.  
Cycloalkenes react in a similar way to alkenes.

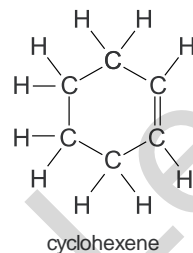

- (a) Cyclohexene is an unsaturated hydrocarbon.  
(i) What is meant by the term unsaturated? [1]  
(ii) What is meant by the term hydrocarbon? [1]
- (b) Construct the equation for the complete combustion of cyclohexene. [1]
- (c) Cyclohexene reacts with bromine.  
This is an addition reaction.  
(i) Write the molecular formula of the product of this reaction. [1]  
(ii) What would be observed in this reaction? [1]
- (e) Another cycloalkene has the following percentage composition by mass.  
C, 88.2%; H, 11.8%  
(ii) The cycloalkene has a relative molecular mass, *Mr*, of 68.  
Draw the structure of the cycloalkene, showing all of the atoms and all of the bonds. [1]

**SOLUTION**

- (a) (i) Unsaturated refers to presence of atleast one carbon carbon double bond  
(ii) An organic compound containing hydrogen and carbon atoms only.
- (b)  $2\text{C}_6\text{H}_{10} + 17\text{O}_2 \rightarrow 12\text{CO}_2 + 10\text{H}_2\text{O}$ .

- (c) (i)  $C_6H_{10}Br_2$   
(double bond breaks and  $Br_2$  molecule attaches)
- (ii) Red brown bromine decolourizes
- (e) (ii) The cycloalkene has a relative molecular mass,  $M_r$ , of 68.  
Draw the structure of the cycloalkene, showing all of the atoms and all of the bonds.

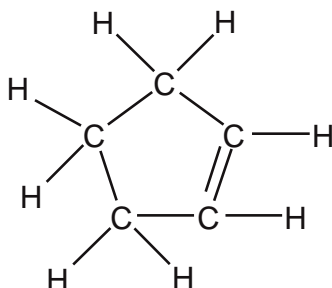

### 11.3 Alcohols

39

[N06/P2/QB9/d]

- (d) Ethanoic acid can be produced by the bacterial fermentation of glucose,  $C_6H_{12}O_6$ . During this process glucose is first oxidised to ethanol.
- (i) Write an equation for the fermentation of glucose to form ethanol and carbon dioxide. [1]
- (ii) State the reagents and conditions required for ethanol to be oxidised to ethanoic acid in the laboratory. [2]

#### SOLUTION

- (d) (i)  $C_6H_{12}O_6 \rightarrow 2C_2H_5OH + 2CO_2$ .
- (ii) Reagents: Potassium dichromate + concentrated sulphuric acid  
Conditions: Reflux at room temperature

40

[J07/P2/QB11/a,b,c(i,iii),d]

The table shows the formula of the first three members of the alcohol homologous series.

| alcohol  | formula    |
|----------|------------|
| methanol | $CH_3OH$   |
| ethanol  | $C_2H_5OH$ |
| propanol | $C_3H_7OH$ |

- (a) Deduce the general formula for the alcohol homologous series. [1]
- (b) Name the products of the complete combustion of methanol. [1]
- (c) (i) Write an equation for the production of ethanol from ethene and state the conditions under which the reaction takes place. [2]
- (iii) Explain why ethanol made from ethane is a non-renewable fuel but that made from glucose is a renewable fuel. [2]
- (d) Propanol reacts in a similar way to ethanol.

Name the organic product of the reaction between propanol and warm acidified potassiumdichromate (VI).

[1]

**SOLUTION**

- (a)  $C_nH_{2n+1}OH$   
 (b) Carbon dioxide and water  
 (Hydrocarbons on complete combustion produce  $CO_2$  and  $H_2O$ )  
 (c) (i)  $C_2H_4 + H_2O \rightarrow C_2H_5OH$   
 Conditions: High temperature of around  $300^\circ C$   
 High pressure of about 70 atm  
 Catalyst (phosphoric acid)  
 (iii) Ethene is obtained from crude oil, which is a finite source (non renewable)  
 Glucose is obtained from plants which is a renewable source. That is why ethanol made from glucose is said to be a renewable fuel.  
 (d) Propanoic acid  
 (Propanol is oxidised to Propanoic acid)

**41**

[J09/P2/QB9/b,c]

Alcohols are an homologous series of organic chemical compounds.  
 The table shows some information about different alcohols.

| alcohol  | formula       | boiling point / $^\circ C$ |
|----------|---------------|----------------------------|
| methanol | $CH_3OH$      | 65                         |
| ethanol  | $C_2H_5OH$    | 78                         |
| propanol | $C_3H_7OH$    | 97                         |
| pentanol | $C_5H_{11}OH$ | 138                        |

- (b) (i) Estimate the boiling point of butanol [1]  
 (ii) A molecule of the alcohol hexanol contains six carbon atoms. Write the formula of hexanol. [1]  
 (c) Ethanol can be manufactured from ethene.  
 Ethene reacts with steam in the presence of an acid catalyst to form ethanol.  
 (i) Write an equation for the reaction between ethene and steam. [1]  
 (ii) Name the **type** of reaction that takes place. [1]

**SOLUTION**

- (b) (i)  $117^\circ C$   
 (any value between  $105$  and  $130^\circ C$ )  
 (iii)  $C_6H_{13}OH$   
 (General formula =  $C_nH_{2n+1}OH$ )  
 (c) (i)  $C_2H_4 + H_2O \rightarrow C_2H_5OH$   
 (ii) Addition reaction  
 (Other possible answer: hydration)

**42**

[N09/P2/QA2/a,b]

In the presence of yeast, aqueous glucose,  $C_6H_{12}O_6$ , is changed into carbon dioxide and ethanol.

- (a) Write the equation for this reaction. [1]  
 (b) Name this reaction. [1]

**SOLUTION**



- (a)  $C_6H_{12}O_6 \rightarrow 2C_2H_5OH + 2CO_2$ .  
(b) Fermentation

**43** [J10/P2/QA5/c,d,e]

- (c) The equation for process 2 is shown below.  
 $C_6H_{12}O_6(aq) \rightarrow 2C_2H_5OH(aq) + 2CO_2(g)$   
(i) Describe **two** essential conditions required for efficient fermentation. [2]  
(ii) Suggest **one** advantage of manufacturing ethanol by process 2 rather than by process 1. [1]
- (d) Process 2 makes an aqueous solution of ethanol. Suggest a method of purification that can be used to remove water from the aqueous ethanol. [1]
- (e) Describe a chemical test which could be used to positively identify the carbon dioxide formed during fermentation.  
test  
observation [1]

**SOLUTION**

- (c) (i) Temperature between 25°C to 40°C  
yeast(enzyme) as catalyst  
(ii) In process 2 the carbon dioxide produced is used by plants during photosynthesis to make more glucose.  
Other advantages: renewable raw materials used, lower temperature required, less energy consuming.
- (d) Fractional distillation  
Fractional distillation is used to separate a mixture of two or more miscible liquids having different boiling points.
- (e) Test: Pass the gas through limewater  
Observation: limewater turns milky

**44** [N10/P2/QA2]

Ethanol can be made both by fermentation and by the addition of steam to ethene.

- (a) (i) Name the organic compound required for fermentation. [1]  
(ii) State the conditions under which fermentation most readily takes place. [2]
- (b) Write an equation for the reaction between steam and ethene. [1]
- (c) Ethanol,  $C_2H_5OH$ , reacts with ethanoic acid,  $CH_3COOH$ .  
 $CH_3COOH + C_2H_5OH \rightarrow CH_3COOC_2H_5 + H_2O$   
(i) Name the compound  $CH_3COOC_2H_5$ . [1]  
(ii) What name is given to this type of chemical reaction? [1]
- (d) (i) Name the third member of the alcohol homologous series. [1]  
(ii) Draw the structural formula of this compound, showing all atoms and bonds. [1]

**SOLUTION**

- (a) (i) Glucose  
 $C_6H_{12}O_6(aq) \rightarrow 2C_2H_5OH(aq) + 2CO_2(g)$   
(ii) Temperature within range 20–40°C;  
Presence of yeast **and absence of oxygen**
- (b)  $C_2H_4 + H_2O \rightarrow C_2H_5OH$   
Alkenes react with water at **270-300°C**, **60-70atm** and in presence of  $H_3PO_4$  to form alcohols
- (c) (i) Ethyl ethanoate

- (ii) Part of alcohol is named first and then part of acid ending with-oate  
Esterification  
Condensation of an alcohol and an acid produces an ester **and this process** is called Esterification
- (d) (i) Propanol  
Alcohol containing three carbon **atoms** is called propanol
- (ii)

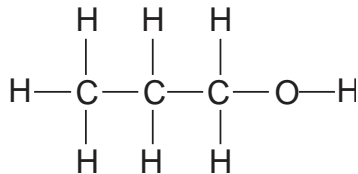

**45** [N10/P2/QB6/c]

- (c) Methane is a member of the alkane homologous series.
- (i) Describe how the boiling points of unbranched alkanes vary with the size of their molecules. [1]
- (ii) Alkanes can be cracked to form alkenes. State the conditions required for cracking alkanes. [2]

**SOLUTION**

- (c) (i) Larger molecules have higher boiling points  
(ii) High temperature(**550c and above**)  
Catalyst (aluminium oxide)

**46** [J11/P2/QB10/a,b,c(i,iii)]

Glucose, C<sub>6</sub>H<sub>12</sub>O<sub>6</sub>, is one of the products of photosynthesis.

- (a) State the empirical formula for glucose. [1]
- (b) (i) Write an equation to show how glucose is formed in photosynthesis. [1]  
(ii) Give the essential conditions for this process. [2]
- (c) (i) State **two** essential conditions for fermentation to take place. [2]  
(iii) Suggest one possible problem in making biofuels by fermentation. [1]

**SOLUTION**

- (a) CH<sub>2</sub>O  
Empirical formula shows the **simplest whole number ratio** of the atoms present in a compound
- (b) (i) 6CO<sub>2</sub> + 6H<sub>2</sub>O → C<sub>6</sub>H<sub>12</sub>O<sub>6</sub> + 6O<sub>2</sub>  
(ii) Needs sunlight, chlorophyll, enzyme and a temperature range of 20 to 40 °C
- (c) (i) Temperature range of 20 to 40 °C and presence of moisture/water  
(iii) CO<sub>2</sub> is produced which is a greenhouse gas  
Other conditions include: presence of **yeast, moisture, neutral pH, anaerobic** conditions

**47** [J12/P2/QB9/d,e]

- (d) Methanol can be used as a fuel.  
Construct the equation for the complete combustion of methanol. [1]
- (e) Methanol can be oxidised to form methanoic acid.

- (i) State the reagents and conditions needed for this reaction. [2]  
 (ii) Draw the structure of methanoic acid. [1]

**SOLUTION**

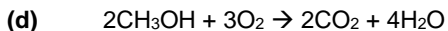

- (e) (i) Reagent: Potassium dichromate  
 Condition: Heat/reflux  
 (Other possible reagents: Potassium manganate (VII) / Potassium permanganate / potassium manganate)  
 (ii)

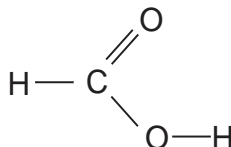

\*Explanations and other possible answers in Italics

**48** [N12/P2/QA1/b(i)]

- (b) Choose from the following compounds to answer the questions below.  
**calcium carbonate**      **carbon dioxide**      **carbon monoxide**      **ethane**  
**glucose**                  **methane**                  **propane**                  **sodium oxide**  
**sucrose**                  **water**                  **zinc oxide**
- Each compound can be used once, more than once or not at all.  
 Which compound  
 (i) is a product of fermentation, [1]

**SOLUTION**

- (b) (i)  $\text{CO}_2$   
 ( $\text{C}_6\text{H}_{12}\text{O}_6 \rightarrow 2\text{C}_2\text{H}_5\text{OH} + 2\text{CO}_2$ )

**49** [N12/P2/QA4]

- Wood is made up of many different carbon compounds.  
 (a) Describe how carbon compounds are made in plants by photosynthesis. [3]  
 (b) When wood is heated in the absence of air, the carbon compounds in the wood decompose.

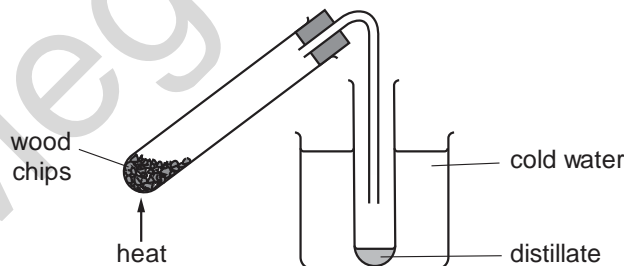

The distillate contains a number of organic compounds, including

**ethanoic acid**  
**ethanal**

**ethanol**  
**methanol**

- (i) When calcium hydroxide is added to the distillate, it neutralises the ethanoic acid. Name the salt formed in this neutralisation. [1]
- (ii) Ethanal can be removed from the distillate by a second distillation. On what physical property of ethanal does this distillation depend? [1]
- (iii) The composition by mass of ethanal is C 54.5%, H 9.1%, O 36.4%. Calculate the empirical formula of ethanal. [2]
- (c) Ethanol reacts with ethanoic acid to form the ester ethyl ethanoate.
- (i) Complete the following formula for ethyl ethanoate.

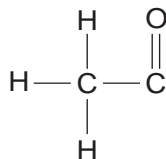

- (ii) State a commercial use for esters. [1]

**SOLUTION**

- (a) Plants take in carbon dioxide and water in the presence of sunlight and chlorophyll to form glucose

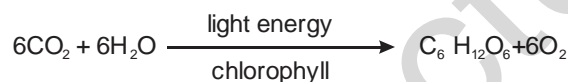

- (b) (i) Calcium ethanoate  
(ii) Boiling point  
(fractional distillation separates compounds on the basis of their boiling points)
- (iii)
- | Element      | C                      | H                    | O                      |
|--------------|------------------------|----------------------|------------------------|
| Percentage   | 54.5                   | 9.1                  | 36.4                   |
| $A_r$        | 12                     | 1                    | 16                     |
| No. of moles | $54.5/12$<br>$= 4.542$ | $9.1/1$<br>$= 9.1$   | $36.4/16$<br>$= 2.275$ |
| Simple ratio | $4.542/2.275$<br>$= 2$ | $9.1/2.275$<br>$= 4$ | $2.275/2.275$<br>$= 1$ |
- Thus, empirical formula =  $\text{C}_2\text{H}_4\text{O}$

- (c) (i) **When**

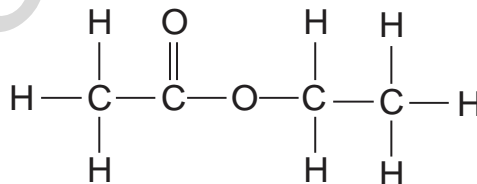

- (ii) Esters are used as solvents

(They are also used in formation of flavourings, polyesters, terylene, nail varnish removers, fuels, plasticizers and perfumes)

50

[J13/P2/QB8]

Alcohols are a homologous series of organic compounds.  
The table shows information about some alcohols.

| alcohol  | molecular formula                | melting point / °C | density / g / cm <sup>3</sup> |
|----------|----------------------------------|--------------------|-------------------------------|
| Methanol | CH <sub>4</sub> O                | -98                | 0.79                          |
| Ethanol  | C <sub>2</sub> H <sub>6</sub> O  | -114               | 0.79                          |
|          | C <sub>3</sub> H <sub>8</sub> O  | -126               | 0.80                          |
| Butanol  | C <sub>4</sub> H <sub>10</sub> O |                    |                               |
| Decanol  |                                  | 7                  | 0.83                          |

- (a) Which group of atoms (functional group) must be present in the homologous series of alcohols? [1]
- (b) Name the alcohol with the molecular formula C<sub>3</sub>H<sub>8</sub>O. [1]
- (c) (i) Deduce the general formula for an alcohol. [1]  
(ii) A molecule of decanol has ten carbon atoms.  
What is the molecular formula for decanol? [1]
- (d) It is more difficult to estimate the melting point of butanol than to estimate its density.  
Use the data in the table to explain why. [1]
- (e) When warmed in the presence of concentrated sulfuric acid, butanol reacts with ethanoic acid to form an ester.  
Name and draw the structure, showing all the atoms and all the bonds, of this ester. [2]
- (f) Ethanol reacts with oxygen in the air to form ethanoic acid.  
Describe another method by which ethanol can be converted into ethanoic acid. [2]
- (g) Butanol can burn in a **limited** supply of air.  
Name **two** products of this reaction. [1]

**SOLUTION**

- (a) OH
- (b) Propanol
- (c) (i) C<sub>n</sub>H<sub>2n+1</sub>OH  
(ii) C<sub>10</sub>H<sub>22</sub>O
- (d) Melting point does not have a regular trend down the series but density does.
- (e) Butyl ethanoate

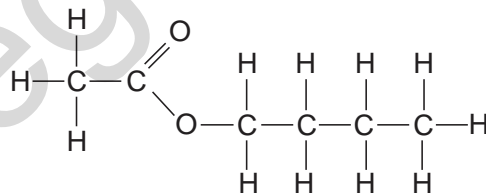

- (f) Heat with an acid in the presence potassium dichromate or potassium manganate.
- (g) Carbon monoxide and water. Melting point does not have a regular trend down the series but density does.

51

[J14/P2/QB8/a,d,e]

Butan-1-ol,  $\text{CH}_3\text{CH}_2\text{CH}_2\text{CH}_2\text{OH}$ , and ethanol,  $\text{CH}_3\text{CH}_2\text{OH}$ , are both alcohols. Alcohols, such as ethanol, react with sodium to form hydrogen.

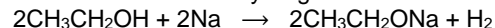

- (a) Construct the equation to show the reaction of butan-1-ol with potassium. [1]  
 (d) Ethanol reacts with ethanoic acid to make an organic compound. Draw the structure, showing all the atoms and all the bonds, of this organic compound. [1]  
 (e) Describe the manufacture of ethanol starting from glucose. Include an equation and the conditions needed. [3]

**SOLUTION**

- (a)  $2\text{CH}_3\text{CH}_2\text{CH}_2\text{CH}_2\text{OH} + 2\text{K} \rightarrow 2\text{CH}_3\text{CH}_2\text{CH}_2\text{CH}_2\text{OK} + \text{H}_2$ .  
 (d)

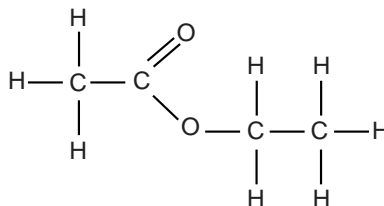

- (e) Glucose is warmed at a temperature of around  $30^\circ\text{C}$ , in the absence of air. Yeast is used as a catalyst and carbon dioxide and ethanol are produced.  
 $\text{C}_6\text{H}_{12}\text{O}_6 \rightarrow 2\text{CO}_2 + 2\text{C}_2\text{H}_5\text{OH}$ .

52

[N14/P2/QB7/a,b,c,d]

The alkanes are a homologous series of hydrocarbons.

- (a) Give the name of another homologous series of hydrocarbons. [1]  
 (b) The graph below shows how the melting points of the first nine alkanes vary with the number of carbon atoms.

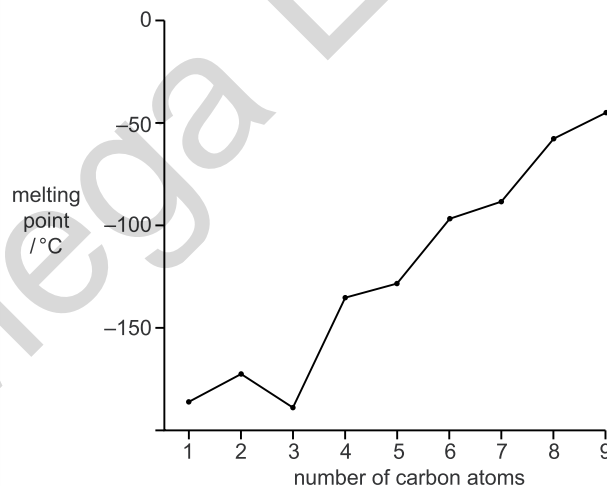

Describe how the melting points of the alkanes with more than two carbon atoms vary as the number of carbon atoms increases. [2]

- (c) Nonane is an alkane with nine carbon atoms.  
Give the molecular formula for nonane. [1]
- (d) One mole of undecane,  $C_{11}H_{24}$ , is cracked to form a mixture containing one mole of ethene, one mole of propene and one mole of another hydrocarbon.  
(i) Construct the equation for this reaction. [1]  
(ii) Explain why oil companies crack the longer chain hydrocarbons. [2]

**SOLUTION**

- (a) Alkenes  
(Other possible answers: cycloalkanes / alkynes / arenes)
- (b) Melting points increase with increasing number of carbon atoms. Although, the increase in melting point from even number to odd number of carbon atoms is less than from odd to even number.
- (c)  $C_9H_{20}$   
(General formula of alkane:  $C_nH_{2n+2}$ )
- (d) (i)  $C_{11}H_{24} \rightarrow C_2H_4 + C_3H_6 + C_6H_{14}$ .  
(ii) • Fractions with longer carbon chains are not in high demand  
• Cracking is done to produce petrol (or diesel) which is in high demand  
(Cracking is also done to produce various alkenes)

**53**

**[N15/P2/QA2]**

Plants contain many different types of carbon compounds.

- (a) Carbon compounds are made in plants by photosynthesis.  
Write the overall equation for photosynthesis and state the conditions required for this process. [3]
- (b) Starch is a polymer found in plants.  
Starch can be hydrolysed.  
(i) Give the name of the product formed when starch is hydrolysed. [1]  
(ii) Give the reagent and conditions needed to hydrolyse starch. [2]
- (c) When wood chips are heated in the absence of air, a colourless distillate is formed.

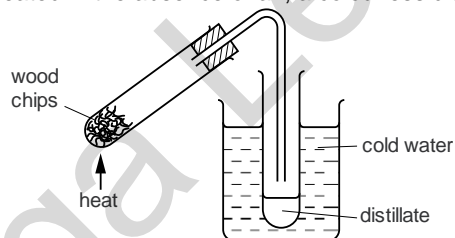

The distillate contains ethanoic acid, esters and other organic compounds.

- (i) Ethanoic acid reacts with calcium hydroxide to form a salt and water.  
Give the name and formula of the salt formed. [2]
- (ii) One of the esters in the distillate has the molecular formula,  $C_4H_8O_2$ .  
Draw the structure of an ester with this formula, showing all the atoms and all the bonds. [1]
- (iii) The distillate also contains a compound with the following composition.

| element  | percentage by mass |
|----------|--------------------|
| carbon   | 37.5               |
| hydrogen | 12.5               |
| oxygen   | 50.0               |

Deduce the empirical formula of this compound.  
empirical formula

[2]

**SOLUTION**

- (a)  $6\text{CO}_2 + \text{H}_2\text{O} \rightarrow \text{C}_6\text{H}_{12}\text{O}_6 + 6\text{O}_2$   
Conditions: chlorophyll and light
- (b) (i) Glucose (starch is a polymer made of glucose monomers)  
(ii) Reagent: concentrated sulfuric acid/amylase  
Conditions: Reflux/37°C and pH 7
- (c) (i) Name:  $(\text{CH}_3\text{COO})_2\text{Ca}$   
Formula: Calcium Ethanoate or calcium acetate  
 $(\text{CH}_3\text{COOH} + \text{Ca}(\text{OH})_2 \rightarrow (\text{CH}_3\text{COO})_2\text{Ca} + \text{H}_2\text{O}.)$

(ii)

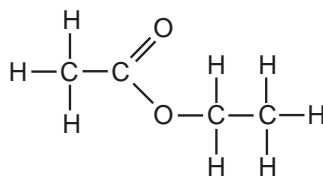

Ethyl ethanoate

(Could be: methyl propanoate, propyl methanoate)

(iii)

|                  | C                 | H               | O               |
|------------------|-------------------|-----------------|-----------------|
| %age ratio       | 37.5              | 12.5            | 50              |
| Atomic mass      | 12                | 1               | 16              |
| Molar ratio      | $37.5/12 = 3.125$ | $12.5/1 = 12.5$ | $50/16 = 3.125$ |
| Simplified ratio | 1                 | 4               | 1               |

$\text{CH}_4\text{O}$

**54**

**[J16/P2/QB9/d]**

Carbon monoxide reacts with hydrogen in a reversible reaction.

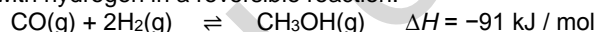

The reaction reaches an equilibrium if carried out in a closed container.

(d) Methanol and compound X react together to form methyl butanoate.

(i) Name X.

[1]

(ii) The reaction is normally carried out using a catalyst.

Name a suitable catalyst for this reaction.

[1]

**SOLUTION**

- (d) (i) **Butanoic acid**  
(Alcohol and acid react to give esters)
- (ii) **Conc Sulfuric acid**

**11.4 Carboxylic Acid**

**55**

**[J05/P2/QB10/a,b,c,d]**

All members of the carboxylic acid homologous series contain the  $-\text{CO}_2\text{H}$  group.

The table shows the formula of the first three members of this homologous series.

| carboxylic acid | formula                          |
|-----------------|----------------------------------|
| methanoic acid  | $\text{HCO}_2\text{H}$           |
| ethanoic acid   | $\text{CH}_3\text{CO}_2\text{H}$ |



|                |               |
|----------------|---------------|
| propanoic acid | $C_2H_5CO_2H$ |
|----------------|---------------|

- (a) Name the unbranched carboxylic acid that has four carbon atoms per molecule. [1]  
 (b) Give the formula of the sixth member of the carboxylic acid homologous series. [1]  
 (c) Ethanol,  $C_2H_5OH$ , reacts with ethanoic acid to make ethyl ethanoate.  
 Draw the structure of ethyl ethanoate. [1]  
 (d) Name a reagent that can be used to convert ethanol into ethanoic acid. [1]

**SOLUTION**

- (a) Butanoic acid  
 (b)  $C_5H_{11}CO_2H$   
 (General formula:  $C_nH_{2n+1}CO_2H$ )  
 (c)

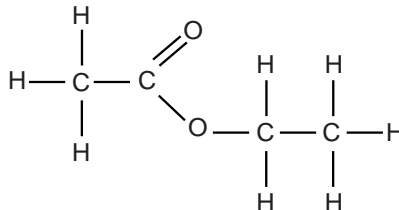

- (d) Acidified potassium dichromate (VI)  
 (Alternative answer: oxygen/acidified potassium manganate (VII))

**56**

**[N05/P2/QA4]**

This table shows some information about two homologous series; the alkanes and the acid chlorides.

| Alkanes     | acid chlorides     |              |
|-------------|--------------------|--------------|
|             | formula            | name         |
| $C_2H_6$    | ethanoyl chloride  | $CH_3COC/$   |
| $C_3H_8$    |                    | $C_2H_5COC/$ |
| $C_4H_{10}$ | butanoyl chloride  | $C_3H_7COC/$ |
| $C_5H_{12}$ | pentanoyl chloride | $C_4H_9COC/$ |

Use the information in the table to answer the following questions.

- (a) Name the acid chloride with the highest boiling point. [1]  
 (b) Deduce the name of the acid chloride with the formula  $C_2H_5COC/$ . [1]  
 (c) The general formula for alkanes is  $C_xH_{(2x+2)}$ .  
 Deduce the general formula for acid chlorides. [1]  
 (d) (i) Name the products of the complete combustion of an alkane.  
 (ii) Would you expect the products of complete combustion of the acid chlorides to be the same as in (i)? Explain your reasoning. [2]

**SOLUTION**

- (a) Pentanoyl chloride  
 (Boiling point increases as the number of carbon atoms increases)  
 (b) Propanoyl chloride  
 (c)  $C_nH_{(2n-1)}OCl$   
 (d) (i) Carbon dioxide and water  
 (ii) No, the presence of Cl atom in the acid chloride molecule is likely to produce HCl gas when acid chlorides are burnt.

Acidified potassium dichromate (VI)  
(Alternative answer: oxygen/acidified potassium manganate (VII))

57

[N06/P2/QB9/a,b]

Both ethanoic acid and butanoic acid are found in some plants and bacteria.

- (a) Draw the structure of butanoic acid showing **all** atoms and bonds. [1]  
 (b) Explain: [1]  
 (i) what is meant by a weak acid, [1]  
 (ii) how you could show that butanoic acid is a weak acid. [2]

**SOLUTION**

(a)

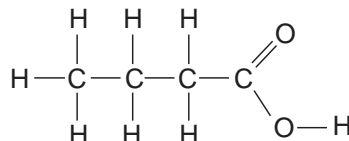

- (b) (i) An acid that is not completely ionised in solution  
 (Weak acid has high proportion of unionised molecules in solution and a small proportion of H<sup>+</sup> ions in solution)  
 (ii) Test butanoic acid with universal indicator, universal indicator will turn yellow/orange  
 (Other possible answer: test butanoic acid with pH meter, pH will be in between 3 and 7 indicating that it is a weak acid)

58

[J07/P2/QA4/b,d]

Structures of six organic compounds are shown.

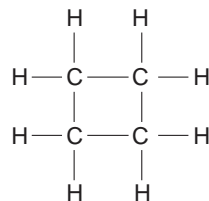

compound A

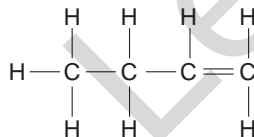

compound B

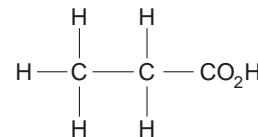

compound C

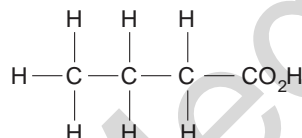

compound D

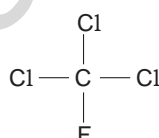

compound E

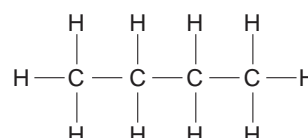

compound F

- (b) Which compound is butanoic acid? [1]  
 (d) Name compound B. [1]

**SOLUTION**

- (b) D  
 (Butanoic acid contains 4 carbon atoms and a carboxylic group)  
 (d) Butene  
 (Compound B contains 4 carbon atoms and a double bond)

59

[J07/P2/QA8/a,b]

Between the 13th and the 19th Century artists used a green pigment called verdigris. They made the pigment by hanging copper foil over boiling vinegar.

- (a) Vinegar is an aqueous solution of ethanoic acid.  
Draw the structure of ethanoic acid. [1]
- (b) During the preparation of verdigris, copper atoms, oxygen molecules and hydrogen ions combine to form copper(II) ions and water.  
Write the ionic equation for this reaction. [2]

**SOLUTION**

(a)

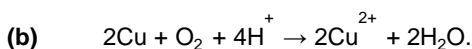
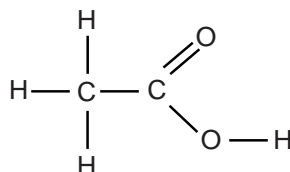

60

[N07/P2/QA5/b(i)]

- (b) Tartaric acid can also be extracted from grape juice.  
The structure of tartaric acid is shown below.

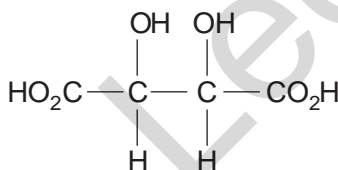

- (i) Deduce the empirical formula of tartaric acid. [1]

**SOLUTION**

- (b) (i)  $\text{C}_2\text{H}_3\text{O}_3$   
(Molecular formula of tartaric acid is  $\text{C}_4\text{H}_6\text{O}_6$ )

61

[N07/P2/QB8/a,b]

Propanoic acid,  $\text{C}_2\text{H}_5\text{CO}_2\text{H}$ , is a weak acid.

- (a) Explain what is meant by the term *weak acid*. [1]
- (b) Propanoic acid reacts with sodium carbonate. Write the equation for this reaction. [1]

**SOLUTION**

- (a) An acid which only partially dissociates when dissolved in water  
(Weak acids do not ionize completely when dissolved in water)
- (b)  $2\text{C}_2\text{H}_5\text{CO}_2\text{H} + \text{Na}_2\text{CO}_3 \rightarrow 2\text{C}_2\text{H}_5\text{CO}_2\text{Na} + \text{CO}_2 + \text{H}_2\text{O}$ .

62

[N08/P2/QA3]

Household waste can be disposed of by being dumped into landfill sites, recycled or burnt.

In a landfill site, bacteria break down vegetable waste to produce a mixture of gases.

- (a) Name **two** gases which are likely to be formed by this bacterial action. [2]  
 (b) A small amount of butanoic acid is also formed by bacterial action in landfill sites. Draw the structure of butanoic acid. [1]  
 (c) A type of 'oil' can be made from the cellulose in waste paper. The waste paper is heated at 350 °C under high pressure and in the presence of a nickel catalyst. The equation for this reaction is shown.

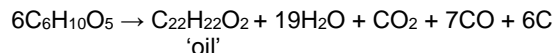

- (i) State the function of a catalyst. [1]  
 (ii) The 'oil',  $\text{C}_{22}\text{H}_{22}\text{O}_2$ , can be used for heating. Write an equation for the complete combustion of this 'oil'. [2]

**SOLUTION**

- (a) Methane and carbon dioxide  
 (b)

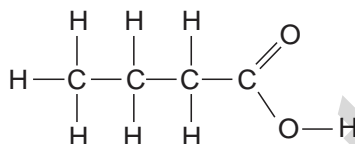

- (c) (Butanoic acid contains four carbons including carbon atom of the carboxylic acid group)  
 (i) It speeds up the rate of the reaction  
 (Other possible answers: It lowers the activation energy of the reaction and reduces the time taken for the reaction to complete)  
 (ii)  $\text{C}_{22}\text{H}_{22}\text{O}_2 + 26\frac{1}{2}\text{O}_2 \rightarrow 22\text{CO}_2 + 11\text{H}_2\text{O}$ .

63

[N08/P2/QB9/d]

- (d) The sweat glands in the skin produce small amounts of lactic acid.

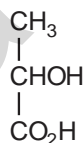

lactic acid

Lactic acid reacts with ethanol to form an ester.

- (i) State the conditions needed to form an ester. [2]  
 (ii) Draw the structure of the ester produced by the reaction of lactic acid with ethanol. [1]

**SOLUTION**

- (d) (i) Concentrated sulphuric acid Reflux the mixture at 170-180 C

(ii)

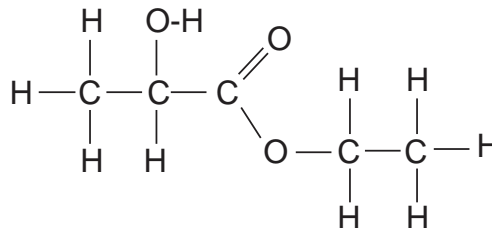

(OH from lactic acid and H from ethanol are removed to make an ester + water)

64

[J10/P2/QB8/a(i,ii),b,c]

An ester is made from a carboxylic acid and an alcohol.

The carboxylic acid has the molecular formula  $\text{C}_4\text{H}_8\text{O}_2$ . Analysis of the alcohol shows it has the following percentage composition by mass: 52.2% carbon; 13.0% hydrogen; 34.8% oxygen.

- (a) (i) Suggest a possible name for the carboxylic acid. [1]  
 (ii) Draw a possible structure for the carboxylic acid. [1]  
 (b) Calculate the empirical formula for the alcohol. [2]  
 (c) (i) Name the ester formed when ethanol reacts with ethanoic acid. [1]  
 (ii) Suggest **one** commercial use of this ester. [1]

**SOLUTION**

- (a) (i) Butanoic acid

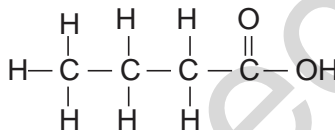

- (ii) Thus, empirical formula =  $\text{C}_2\text{H}_6\text{O}$   
 (c) (i) Ethyl ethanoate  
 (ii) It is used as a solvent  
 Esters are also used for flavourings and aromas.

65

[N11/P2/QB8/a,b,c(iii)]

The table gives some information about the first five members of the carboxylic acid homologous series.

| carboxylic acid | acid formula                              | boiling point / °C |
|-----------------|---|--------------------|
| methanoic acid  | $\text{HCO}_2\text{H}$                    | 101                |
| ethanoic acid   | $\text{CH}_3\text{CO}_2\text{H}$          | 118                |
| propanoic acid  | $\text{C}_2\text{H}_5\text{CO}_2\text{H}$ | 141                |
| butanoic acid   |   | 166                |
| pentanoic acid  | $\text{C}_4\text{H}_9\text{CO}_2\text{H}$ |                    |

- (a) (i) Estimate the boiling point of pentanoic acid. [1]  
 (ii) Draw the structure of butanoic acid.  
 Show all atoms and bonds. [1]  
 (iii) Ethanoic acid reacts with sodium.  
 Write an equation for this reaction. [1]  
 (b) Carboxylic acids react with alcohols to form esters.  
 (i) Name the ester formed when ethanoic acid reacts with ethanol. [1]

- (ii) The diagram shows the repeat unit of poly(ethenyl ethanoate)

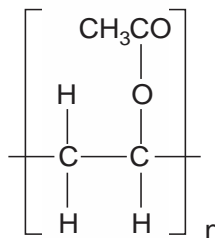

- (iii) Carboxylic acid **X** is an unsaturated compound.  
Give a test for an unsaturated compound.  
test observation

[2]

**SOLUTION**

- (a) (i) 187°C  
(Can be within the range of 175 - 191°C)

- (ii)

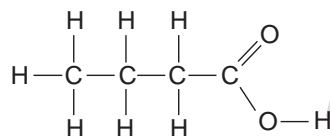

- (iii)  $2\text{CH}_3\text{CO}_2\text{H} + 2\text{Na} \rightarrow 2\text{CH}_3\text{CO}_2\text{Na} + \text{H}_2$

- (b) (i) Ethyl ethanoate  
Name of an **of alcohol** is taken **first** and then the name of **an acid** is named ending with **-oate**.

- (ii)

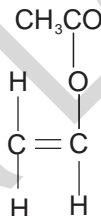

- (c) (iii) **test:** Add aq. Bromine to the compound  
**observation:** brown color of bromine turns to colorless

66

[N13/P2/QA2]

Carboxylic acids are a homologous series containing the  $-\text{CO}_2\text{H}$  group.  
The table shows some properties of the first four carboxylic acids in the series.

| carboxylic acid | molecular formula                            | density in g / cm <sup>3</sup> | boiling point in °C |
|-----------------|--|--------------------------------|---------------------|
| methanoic acid  | CH <sub>2</sub> O <sub>2</sub>               | 1.220                          | 101                 |
| ethanoic acid   | C <sub>2</sub> H <sub>4</sub> O <sub>2</sub> | 1.049                          | 118                 |
| propanoic acid  | C <sub>3</sub> H <sub>6</sub> O <sub>2</sub> | 0.993                          | 141                 |
| butanoic acid   | C <sub>4</sub> H <sub>8</sub> O <sub>2</sub> | 0.958                          | 165                 |

- (a) (i) Describe how the density of these carboxylic acids varies with the number of carbon atoms in the molecule. [1]  
 (ii) Name the carboxylic acid with the molecular formula  $C_2H_4O_2$ . [1]  
 (iii) Draw the structure of propanoic acid, showing all atoms and bonds. [1]
- (b) The next carboxylic acid in this homologous series is pentanoic acid.  
 Pentanoic acid has five carbon atoms.  
 (i) Deduce the molecular formula for pentanoic acid. [1]  
 (ii) Suggest a value for the boiling point of pentanoic acid. [1]
- (c) Butanoic acid,  $C_3H_7CO_2H$ , reacts with sodium to form a salt and a gas.  
 (i) Name the gas. [1]  
 (ii) Give the formula of the salt. [1]
- (d) Esters are formed when carboxylic acids react with alcohols.  
 The reaction is catalysed by hydrogen ions.  
 (i) Describe and explain the effect of a catalyst on reaction rate. [2]  
 (ii) State one commercial use of esters. [1]  
 (iii) The structure of an ester is shown below.

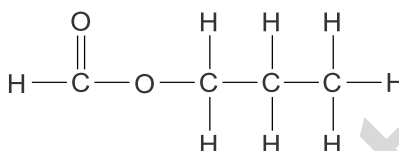

Name this ester.

[1]

**SOLUTION**

- (a) (i) Density decreases as the number of carbon atom increases  
 (ii) Ethanoic acid  
 (iii)

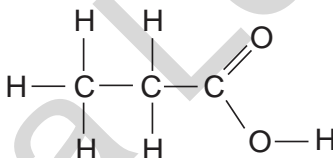

- (b) (i)  $C_5H_{10}O_2$   
 (General formula of carboxylic acids is  $C_n H_{2n+1} COOH$ )
- (ii)  $180-195^\circ C$
- (c) (i) Hydrogen  
 (Na atom replaces a hydrogen atom)
- (ii)  $C_3H_7CO_2Na$
- (d) (i) A catalyst speeds up the rate of chemical reaction by lowering the activation energy.  
 (ii) Esters are used as solvents  
 (Other possible answers: fragrance, perfume, food additive, flavoring, polyester and terylene)  
 (iii) Propyl methanoate

67

[J15/P2/QA1/a(ii,iii,iv),b]

Choose from the following compounds to answer the questions opposite.

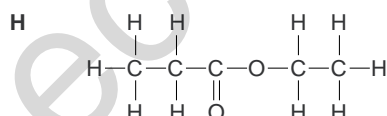
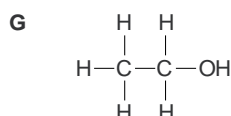
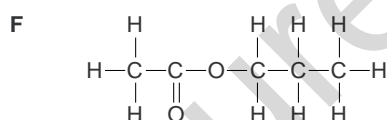
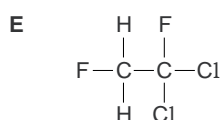
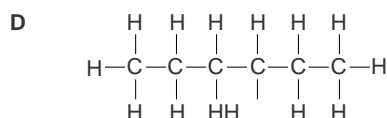
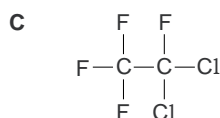
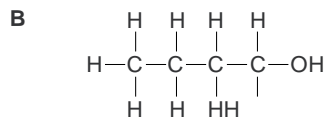
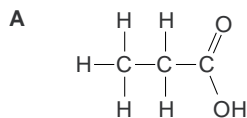

Each compound can be used once, more than once or not at all.

- (a) Give the letter of the compound which
- (ii) is propanoic acid, [1]
  - (iii) is propyl ethanoate, [1]
  - (iv) can be oxidised to ethanoic acid. [1]
- (b) Give the letters of **two** compounds that react together to make an ester. [1]

**SOLUTION**

- (a) (ii) **A** (A three carbon compound containing -COOH group)  
 (iii) **F** (an ester made from condensation of a propanol molecule and an ethanoic acid molecule)  
 (iv) **G** (two carbon alcohol can be oxidized to two carbon carboxylic acid)
- (b) **A and B** or **A and G** (any ethanol can react with any carboxylic acid to produce an ester)

68

[J16/P2/QA3]

Esters are used as food flavourings and solvents.

- (a) Draw the structure of ethyl methanoate, showing all of the atoms and all of the bonds. [1]



- (b) Ethyl ethanoate evaporates at room temperature.
- (i) What is meant by the term *evaporation*? [1]
- (ii) A sample of ethyl ethanoate in a beaker is moved into a colder room. Explain, in terms of the kinetic particle theory, why this results in a decrease in the rate of evaporation. [2]
- (iii) The table shows some information about different esters.

| name             | structure                                       | relative molecular mass ( $M_r$ ) |
|------------------|---|-----------------------------------|
| methyl ethanoate | $\text{CH}_3\text{CO}_2\text{CH}_3$             | 74                                |
| ethyl ethanoate  | $\text{CH}_3\text{CO}_2\text{C}_2\text{H}_5$    | 88                                |
| propyl ethanoate | $\text{CH}_3\text{CO}_2\text{C}_3\text{H}_7$    | 102                               |
| butyl ethanoate  | $\text{CH}_3\text{CO}_2\text{C}_4\text{H}_9$    | 116                               |
| pentyl ethanoate | $\text{CH}_3\text{CO}_2\text{C}_5\text{H}_{11}$ | 130                               |

Which ester has the **lowest** rate of evaporation at room temperature and pressure? Explain your answer. [2]

### SOLUTION

(a)

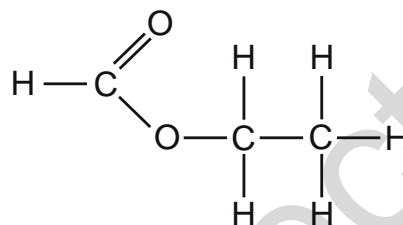

- (b) (i) Evaporation refers to the changing of a liquid to a gas at any random temperature
- (ii) At lower temperature, the molecules have lesser energy and hence move slower than usual. This results in less number of molecules that have enough energy to overcome forces between the molecules and escape
- (iii) Pentyl ethanoate  
Pentyl ethanoate has highest molecular mass (in the given molecules) and hence molecules take maximum time to move about

## 11.5 Macromolecules

69

[N05/P2/QA2]

These diagrams show sections of the polymer chain of two condensation polymers.

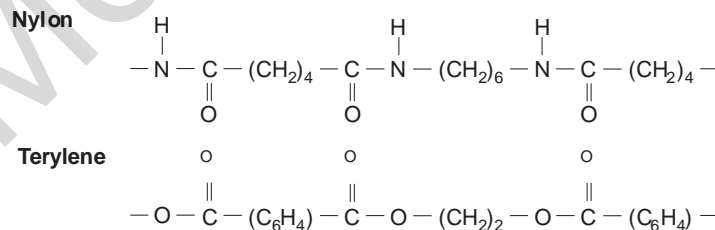

- (a) (i) Draw a circle around an amide linkage in the diagram. Label this **amide**.  
 (ii) Draw a circle around an ester linkage in the diagram. Label this **ester**. [2]
- (b) Name a type of naturally occurring polymer that has a similar linkage to nylon. [1]
- (c) The formulae of the two monomers used to make nylon are shown below.  
**Nylon monomers**  $\text{HOOC}(\text{CH}_2)_4\text{COOH}$   $\text{H}_2\text{N}(\text{CH}_2)_6\text{NH}_2$   
 Deduce the formulae of the two monomers that are used to make *Terylene*.  
**Terylenemonomers** [2]
- (d) Sea fishing nets used to be made from natural fibres. Many nets are now made from nylon. Suggest one **advantage**, other than strength, and one **disadvantage** of using nylon rather than natural fibres to make sea fishing nets. advantage disadvantage [2]

**SOLUTION**

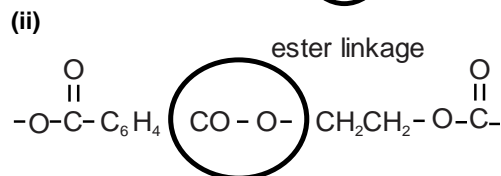
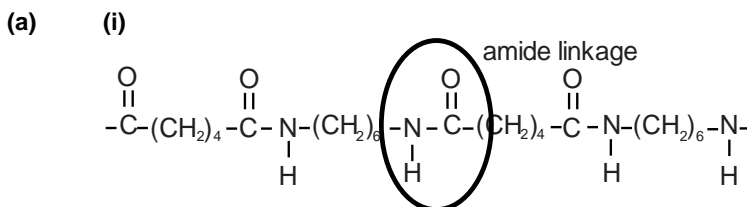

(b) Protein

(c)

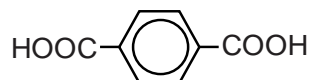

- (d) **Advantage:** Nylon fishing nets are lighter than nets made from natural fibres.  
**Disadvantages:** Nylon fishing nets are slippery in water compared to natural fibre ropes  
 (Another disadvantage: Nylon is non biodegradable)

**70**

[J06/P2/QB11/a,b,c(i,ii),d]

Macromolecules are large molecules built up from many small units.

Proteins and fats are natural macromolecules.

Poly(chloroethene) and poly(ethene) are synthetic macromolecules.

- (a) Name the type of linkage joining the units in fats. [1]
- (b) Proteins can be hydrolysed into monomers by boiling with concentrated hydrochloric acid. [1]  
 (i) Name the monomers produced in this hydrolysis. [1]  
 (ii) Suggest why clothes made from nylon are damaged by concentrated hydrochloric acid. [1]
- (c) Poly(chloroethene) is made from the monomer chloroethene. The structure of chloroethene is shown below.

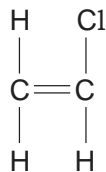

- (i) Draw the structure of poly(chloroethene). [1]  
 (ii) Explain why poly(chloroethene) has a low melting point. [1]  
 (d) State and explain why plastics such as poly(ethene) may cause problems of pollution. [2]

**SOLUTION**

- (a) Ester linkage  
*(Fats are polyesters)*  
 (b) (i) Amino acids  
 (ii) Nylon is hydrolyzed by the acid  
*(Nylon contains amide linkages as those in proteins and hence can be hydrolyzed by HCl).*  
 (c) (i)

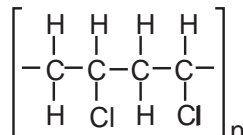

- (ii) Polychloroethene has a low melting point because the weak intermolecular forces do not require lot of energy to be broken.  
 (iii) Bromine decolorizes and addition reaction takes place Polychloroethene does not decolorize bromine because there are no double bonds present in polychloroethene.  
 (d) Plastics are non biodegradable and hence they have to be burnt for disposal. Burning of plastics releases harmful and poisonous substances.

**71**

**[J07/P2/QB12/a,b,c,d(i)]**

The macromolecule below is an addition polymer.

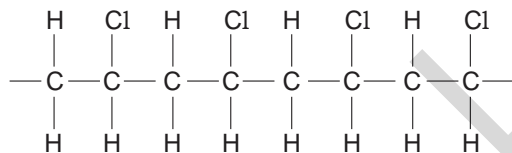

polymer X

- (a) Draw the structure of the monomer from which polymer X is formed. [1]  
 (b) The atoms in polymer X are covalently bonded.  
 (i) Explain what is meant by a covalent bond. [1]  
 (ii) Polymer X is used as an insulating cover for electrical wires.  
 Explain why polymer X does not conduct electricity. [1]  
 (c) Polymer X is non-biodegradable.  
 (i) Describe one pollution problem that this causes. [1]  
 (ii) Polymer X can be disposed of by burning at high temperature. This produces wastegases, some of which are toxic such as hydrogen chloride.  
 The hydrogen chloride can be removed by reacting the waste gases with moist calcium carbonate powder.  
 Name the three products of this reaction. [3]  
 (d) (i) Draw a 'dot-and-cross' diagram for an ethene molecule, C<sub>2</sub>H<sub>4</sub>. You must draw all of the electrons. [2]

**SOLUTION**

(a)

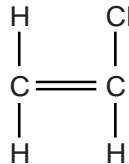

- (b) (i) It is a bond formed by sharing a pair of electrons between non metal atoms  
 (ii) All the electrons of carbon and hydrogen are involved in bonding therefore no free electrons are available.  
 (Mobile electrons are needed to conduct electricity)
- (c) (i) Its disposal needs a large landfill sites and stays for a long time undecomposed  
 (ii) Calcium chloride, carbon dioxide and water  
 (Metal carbonates react with acid to produce a salt, CO<sub>2</sub> and H<sub>2</sub>O)
- (d) (i)

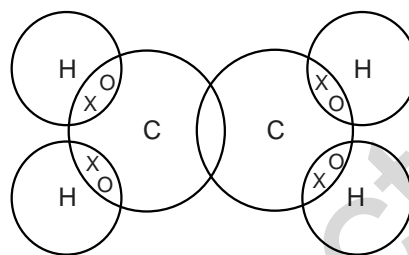

**72**

[N07/P2/QB3/d,e]

(d) *Terylene* has the simplified structure shown.

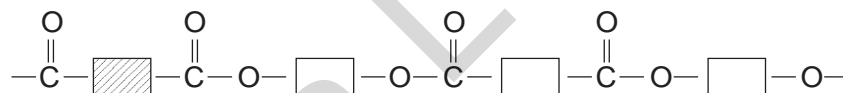

- (i) State the functional groups on the monomers used to make *Terylene*. [1]  
 (ii) State the type of polymerisation that occurs when *Terylene* is made. [1]  
 (iii) State one large scale use of *Terylene*. [1]
- (e) Many problems are caused by the disposal of plastics.  
 Describe one method of disposal of a plastic and a problem caused by this method. [1]

**SOLUTION**

- (d) (i) Carboxylic acid and alcohol  
 (Carboxylic acid and alcohols produces esters)  
 (ii) Condensation polymerization  
 (An H<sub>2</sub>O molecule is removed)  
 (iv) *Terylene* is used to make fibre  
 (Other uses: Clothing/conveyer of fen belts)
- (e) Plastics can be disposed off by burning. It produces poisonous gases, such as CO, causing health and environmental problems

(Other possible answers: Plastics can be recycled – it is difficult to sort out different polymers  
Plastics can be disposed in a landfill – it does not biodegrade)

73

[J09/P2/QA7]

Poly(chloroethene) is an addition polymer. It is often found in solid household waste.  
The diagram shows the repeat unit of poly(chloroethene).

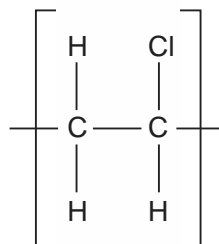

- (a) Draw the structure of the monomer used to make poly(chloroethene). [1]
- (b) One way to dispose of solid household waste is to burn it at a high temperature. The burning of poly(chloroethene) gives the waste gases hydrogen chloride, carbon dioxide and water.
- (i) Balance the following equation to show the burning of poly(chloroethene). [1]  
 $\dots -C_2H_3Cl + \dots O_2 \rightarrow \dots HCl + \dots CO_2 + \dots H_2O$
- (ii) Hydrogen chloride gas is removed from the waste gases by reacting with moist powdered calcium carbonate. Name the solid product formed. [1]
- (c) Name and state the use of a man-made condensation polymer. [2]  
 name of condensation polymer  
 use of condensation polymer

### SOLUTION

(a)

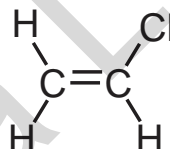

- (b) (i)  $2C_2H_3Cl + 5O_2 \rightarrow 2HCl + 4CO_2 + 2H_2O$ .
- (ii) Calcium chloride  
 $(CaCO_3 + 2HCl \rightarrow CaCl_2 + CO_2 + H_2O)$
- (c) **Name of condensation polymer:** Nylon  
**Use of condensation polymer:** Clothing / fishing nets / ropes / stockings / parachutes / toothbrush bristles / balloons / guitar strings / racquet strings / petrol tanks (Other possible answers:  
**Name of condensation polymer:** Polyester or Terylene  
**Use of condensation polymer:** clothing / sheets / pillowcases / furniture coverings / curtains / carpets / ropes / sails / machinery belts  
**Name of condensation polymer:** PET  
**Use of condensation polymer:** bottles / clothing / sheets / pillowcases / furniture coverings / curtains / carpets / ropes / sails / machinery belts  
**Name of condensation polymer:** Mylar



- (ii) Draw the structure of the monomer used in the manufacture of this polymer. [1]  
 (iii) Explain why this polymer is described as a saturated hydrocarbon. [1]  
 (b) Suggest why this polymer is not destroyed in water. [1]

**SOLUTION**

- (a) (i) Addition polymer  
 Monomers of such polymers have carbon-carbon double bonds.  
 (ii)

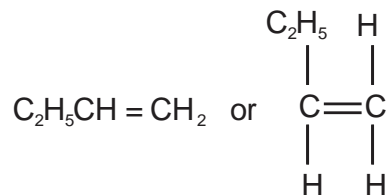

- (iii) The polymer has carbon-carbon single bonds only.  
 Carbons are fully occupied by hydrogen atoms and no more hydrogen atoms can be added making it a saturated hydrocarbon  
 (b) Addition polymers are non-biodegradable  
 This hydrocarbon is soluble in organic solvents only.

**76**

**[J10/P2/QB8/d]**

- (d) *Terylene* is a polyester used to make clothing materials.  
 (i) Draw the partial structure of *Terylene*. Include all the atoms and all the bonds in the ester linkage. [2]  
 (ii) Which type of natural macromolecule contains the ester linkage? [1]

**SOLUTION**

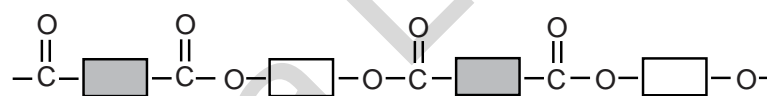
- (d) (i)
- 
- (ii) Fat  
 Lipid or triglyceride can also be written

**77**

**[J11/P2/QA6]**

- Proteins are natural polyamides which can be hydrolysed to form amino acids.  
 (a) Name a synthetic polyamide. [1]  
 (b) The hydrolysis of proteins forms a mixture of colourless amino acids.  
 Describe, with the aid of a labelled diagram, how paper chromatography can be used to identify a mixture of amino acids. [4]

**SOLUTION**

- (a) Nylon  
 Synthetic polyamide refers to man-made polyamides. Other options can be Kevlar, Kermal, Trogamid, Nomex, Twaron, Technon, Tejjiconex, Rilson, Ultramid

(b)

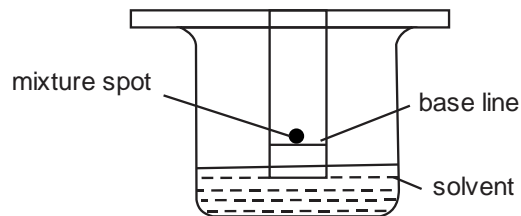

Take a strip of filter paper and draw a base line with pencil at about 2cm from the lower end and place a drop of mixture on the base line. Hang the filter paper into the jar as shown. Pour the solvent into the jar such that the solvent just touches the lower end of the filter paper. Cover the jar with lid to avoid evaporation of solvent. The solvent will rise along the paper taking the components of mixture at different heights (due to difference of solubilities). Filter paper is then removed from the jar, dried and sprayed with a locating agent such as ninhydrin to make the spots of separated amino acids visible.  $R_f$  values are then measured for each spot and compared with the known  $R_f$  values of amino acids.

78

[J12/P2/QA3/b,c,d]

(b) One of the polymer molecules in the plastic waste is made from the monomer Shown below.

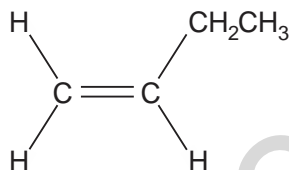

(c) Draw the partial structure of the polymer formed from this monomer showing two repeats. [2]  
Many of the polymers found in the plastic waste are non-biodegradable.

Describe **two** pollution problems caused by the disposal of non-biodegradable polymers. [2]

(d) *Terylene* and nylon are two of the textiles present in the solid waste.  
The partial structure of *Terylene* is shown below.

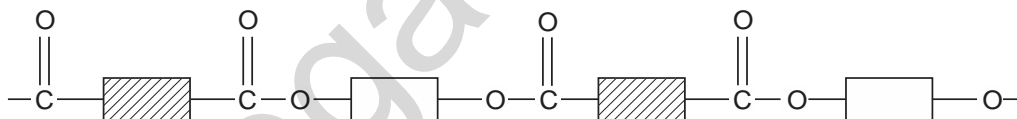

(i) *Terylene* is a polyester.  
What type of polymerisation is used to make *Terylene*? [1]

(ii) Complete the diagram below to show the partial structure for nylon. [1]



(iii) Give the name of one **type** of food that has molecules containing the same linkages as *Terylene*. [1]



**SOLUTION**

(b)

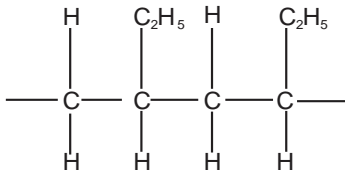

(c) Incineration of such polymers produces hazardous and toxic gases during their disposal  
Non-biodegradable polymers being dumped into the rivers, lakes, streams and seas contaminate water and harm marine life  
(Other pollution problems include: more landfill sites are needed for disposal of such polymers, CO and CO<sub>2</sub> are produced during burning of non biodegradable polymers causing air pollution, leading to global warming)

(d) (i) Condensation polymerization  
(Ester linkages are formed by condensation polymerization by the removal of a water molecule)

(ii)

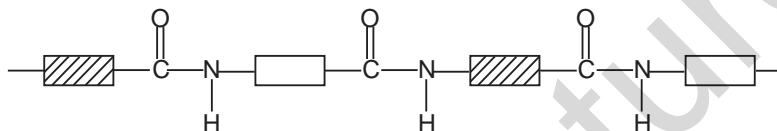

(iii) Fats/Lipids/Oils  
(They have an ester linkages)

**79**

**[N12/P2/QB9/b,c]**

(b) Chlorine is used to make chloroethene.  
The structure of chloroethene is shown below.

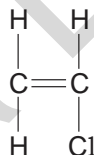

(i) Draw the structure of the polymer poly(chloroethene). [2]  
(ii) Chloroethene is an unsaturated compound.  
Describe a positive test for an unsaturated compound. [2]

(c) Sodium hydroxide is a typical alkali.

It reacts with ethanoic acid to form water and the ionic salt, sodium ethanoate.

(i) Write the formula for the ethanoate ion showing all atoms and bonds. [1]  
(ii) Construct the ionic equation for the reaction of ethanoic acid with sodium hydroxide. [1]

**SOLUTION**

(b) (i)

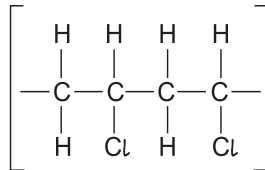

(ii) **Test:** Add aqueous bromine  
**Result:** Aqueous bromine turns colourless

(c) (i)

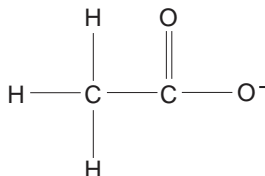

(ii)  $\text{CH}_3\text{COOH} + \text{OH}^- \rightarrow \text{CH}_3\text{COO}^- + \text{H}_2\text{O}$

**80**

**[N13/P2/QB7/c]**

(c) Alkenes such as ethene can undergo addition polymerisation.

(i) State one use of poly(ethene). [1]

(ii) The diagram below shows a section of a polymer chain.

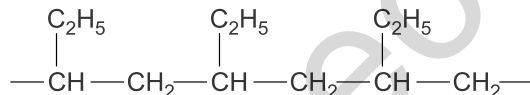

Deduce the structure of the monomer which is used to make this polymer. [1]

**SOLUTION**

(c) (i) Poly ethene is used in making cling films

(Other possible uses: Bottles / bags / packaging / sandwich bags / moisture barrier / damp-proofing / toys / jugs / plates / dustbins / water pipes / screw closures / sacks / gas pipes / bubble wrap / cable coverings / pond linings / ropes / nets / greenhouses / Paints / glues / waxes / (outdoor) furniture e.g. tables / chairs)

(ii)  $\text{C}_2\text{H}_5$   
|  
 $\text{CH}=\text{CH}_2$

**81**

**[J14/P2/QA3/a,b,d,e]**

Proteins, carbohydrates and fats are natural macromolecules.

The partial structure of a protein is shown below.

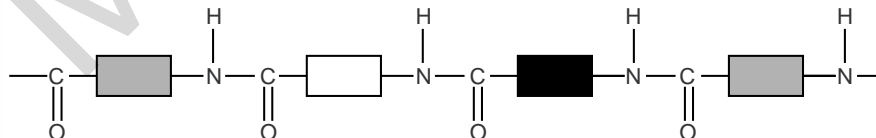

(a) Name the linkage that joins the monomer units in a protein. [1]



polymer B

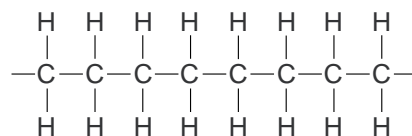

polymer C

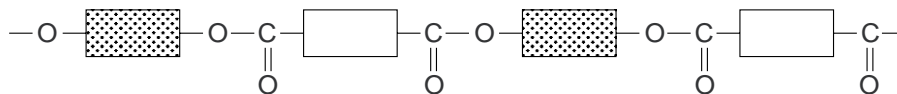

polymer D

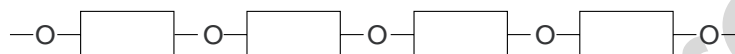

polymer E

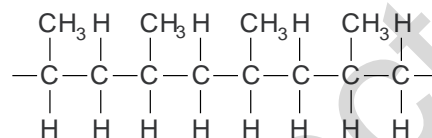

polymer F

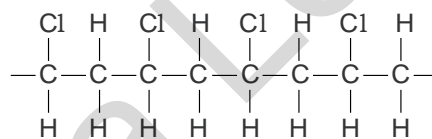

polymer G

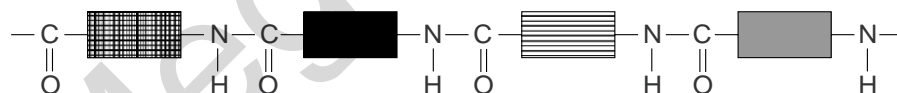

polymer H

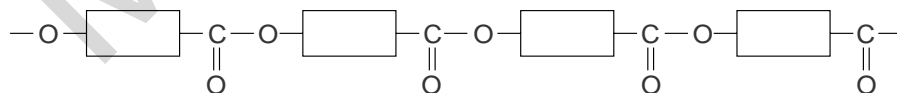

polymer I

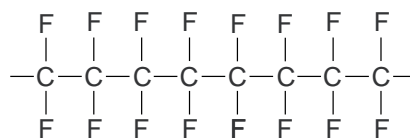

Each polymer can be used once, more than once or not at all.

- (a) Which **two** polymers are polyesters? [1]  
(b) Which polymer is used to make both clingfilm and plastic bags? [1]  
(c) Give the letter of an addition polymer.  
Give the letter of a condensation polymer. [1]  
(d) Give the letter of a polymer that is a saturated hydrocarbon. [1]  
(e) Which polymer could be part of a protein? [1]

SOLUTION

- (a) C and H (polyesters have COO linkage)  
(b) B or F (polyethene or polyvinylchloride is used for the purpose)  
(c) (i) **B/E/F/I** (addition polymers are made of carbon carbon double bond containing monomers)  
(ii) **A/C/D/G/H** (Condensation polymers have either ester linkage, COO or amide linkage, CONH)  
(d) **E/B** (saturated hydrocarbon = carbon carbon single bond)  
(e) **G** (proteins are polyamides with different monomers)

**INDEX**

**2005 June P-2**

|                |              |
|----------------|--------------|
| Q A1(a)        | 202          |
| Q A1(b)        | 40           |
| Q A1(c)        | 139          |
| Q A1(d)        | 3, 6         |
| Q A2(a,b)      | 181          |
| Q A2(c)        | 194          |
| Q A2(d)        | 177          |
| Q A2(e)        | 52           |
| Q A3           | 165          |
| Q A4           | 219          |
| Q A5(a)        | 84           |
| Q A5(b)        | 6            |
| Q A5(c,e)      | 165          |
| Q A5(d)        | 84           |
| Q A6           | 40           |
| Q B10(a,b,c,d) | 247          |
| Q B10(e,f)     | 53           |
| Q B10(g)       | 139          |
| Q B7(a,b)      | 202          |
| Q B7(c)        | 52, 100, 110 |
| Q B8(a)        | 52           |
| Q B8(b)        | 128          |
| Q B8(c,d)      | 153          |
| Q B9           | 157          |

**2005 November P-2**

|               |         |
|---------------|---------|
| Q A1(a,b,c,d) | 163     |
| Q A1(e)       | 41      |
| Q A2          | 256     |
| Q A3          | 139     |
| Q A4          | 248     |
| Q A5(a)       | 53      |
| Q A5(a,b,c)   | 110     |
| Q A6(a)       | 53, 128 |
| Q A6(b)       | 41      |
| Q A7          | 227     |
| Q B10         | 84      |
| Q B11(a,b)    | 193     |
| Q B11(c)      | 181     |
| Q B8          | 203     |
| Q B9(a)       | 166     |
| Q B9(b)       | 128     |

**2006 June P-2**

|             |         |
|-------------|---------|
| Q A1(a)     | 32, 178 |
| Q A1(b)     | 85      |
| Q A1(c,d)   | 163     |
| Q A1(e)     | 6       |
| Q A2        | 21      |
| Q A3        | 220     |
| Q A4(a,b,c) | 186     |

|                |     |
|----------------|-----|
| Q A4(d)        | 54  |
| Q A5(a,b,c)    | 31  |
| Q A5(d)        | 54  |
| Q A6(a,b,d)    | 166 |
| Q A6(c)        | 129 |
| Q A7           | 204 |
| Q B10(a)       | 181 |
| Q B10(b,c)     | 7   |
| Q B11(a,b,c,d) | 257 |
| Q B11(c)       | 227 |
| Q B8(a,b)      | 205 |
| Q B8(c)        | 6   |
| Q B8(d)        | 54  |
| Q B9(a,b)      | 153 |
| Q B9(c)        | 55  |
| Q B9(d)        | 42  |

**2006 November P-2**

|               |         |
|---------------|---------|
| Q A1(a)       | 85, 140 |
| Q A1(a,c)     | 206     |
| Q A1(b)       | 55      |
| Q A2(a)       | 182     |
| Q A2(b)       | 227     |
| Q A3          | 111     |
| Q A4(a,b,e,f) | 167     |
| Q A4(c)       | 22      |
| Q A4(d)       | 164     |
| Q A5(a)       | 7       |
| Q A5(a,b,c)   | 199     |
| Q A5(b)       | 56      |
| Q A5(d)       | 140     |
| Q A6(a)       | 47      |
| Q A6(b,c,d)   | 206     |
| Q A6(e)       | 100     |
| Q B10(a,b,c)  | 86      |
| Q B10(d)      | 182     |
| Q B7(a,b)     | 129     |
| Q B7(c)       | 159     |
| Q B7(d)       | 56      |
| Q B7(e)       | 207     |
| Q B8(a,b,c)   | 160     |
| Q B8(b)       | 112     |
| Q B8(d)       | 56      |
| Q B9(a,b)     | 249     |
| Q B9(c)       | 56      |
| Q B9(d)       | 238     |

**2007 June P-2**

|         |     |
|---------|-----|
| Q A1(a) | 178 |
| Q A1(b) | 221 |
| Q A1(c) | 141 |
| Q A1(d) | 168 |

|                          |         |                          |          |
|--------------------------|---------|--------------------------|----------|
| Q A1(e).....             | 194     | Q B7(d).....             | 228      |
| Q A2(a,d).....           | 57      | Q B8(a,b).....           | 250      |
| Q A2(b).....             | 8       | Q B8(c).....             | 59       |
| Q A2(c).....             | 129     | Q B8(d,e).....           | 259      |
| Q A3.....                | 23      | Q B9.....                | 88       |
| Q A4(a).....             | 221     | <b>2008 June P-2</b>     |          |
| Q A4(b,d).....           | 249     | Q A1(a).....             | 222      |
| Q A4(c).....             | 207     | Q A1(b).....             | 141      |
| Q A5.....                | 87      | Q A1(c).....             | 169      |
| Q A6.....                | 168     | Q A1(d).....             | 130      |
| Q A7(a).....             | 8       | Q A1(e).....             | 179      |
| Q A7(b,c).....           | 186     | Q A2(a,e).....           | 60       |
| Q A7(d).....             | 57      | Q A2(b,c).....           | 9        |
| Q A8(a,b).....           | 250     | Q A2(d).....             | 130      |
| Q A8(c).....             | 57      | Q A3(a,b,c).....         | 23       |
| Q B10(a,b,c).....        | 101     | Q A3(d).....             | 179      |
| Q B10(c).....            | 58      | Q A4(a,d).....           | 228      |
| Q B11(a,b,c,d).....      | 238     | Q A4(b).....             | 47       |
| Q B11(c).....            | 58, 222 | Q A4(c).....             | 223      |
| Q B12(a,b,c,d).....      | 258     | Q A5(a,c).....           | 169      |
| Q B12(d).....            | 58      | Q A5(b).....             | 188      |
| Q B9(a).....             | 164     | Q A5(d).....             | 223      |
| Q B9(b).....             | 42      | Q A6(a,b).....           | 209      |
| Q B9(c).....             | 23      | Q A6(c).....             | 102      |
| Q B9(d).....             | 32      | Q B10(a,b).....          | 182      |
| Q B9(e).....             | 168     | Q B10(c).....            | 61, 113  |
| <b>2007 November P-2</b> |         | Q B10(d).....            | 10       |
| Q A1(a,d).....           | 222     | Q B7(a).....             | 131      |
| Q A1(b).....             | 208     | Q B7(b).....             | 42       |
| Q A1(c).....             | 8       | Q B7(c).....             | 154      |
| Q A1(e).....             | 159     | Q B7(d).....             | 209      |
| Q A1(f).....             | 87      | Q B8(a).....             | 223      |
| Q A2.....                | 18      | Q B8(b,c,d).....         | 228      |
| Q A3(a).....             | 168     | Q B9(a,c).....           | 141      |
| Q A3(b).....             | 222     | Q B9(b).....             | 60       |
| Q A3(b,c).....           | 141     | <b>2008 November P-2</b> |          |
| Q A3(d).....             | 8       | Q A1.....                | 142, 170 |
| Q A4(a,b,c,d).....       | 33      | Q A2(a,b,c).....         | 114      |
| Q A4(e).....             | 178     | Q A2(d,e).....           | 61       |
| Q A5(a).....             | 15      | Q A2(f).....             | 102      |
| Q A5(b).....             | 59, 250 | Q A3.....                | 251      |
| Q A6(a).....             | 187     | Q A4(a).....             | 131      |
| Q A6(b).....             | 208     | Q A4(b).....             | 142      |
| Q A6(c).....             | 113     | Q A4(c).....             | 62       |
| Q A6(d).....             | 8       | Q A5(a).....             | 183      |
| Q A6(e).....             | 130     | Q A5(a,b).....           | 142      |
| Q B10(a,b).....          | 34      | Q A5(b).....             | 62       |
| Q B10(c).....            | 188     | Q A6(a).....             | 143, 170 |
| Q B10(d).....            | 9       | Q A6(b).....             | 224      |
| Q B10(e).....            | 113     | Q A6(c,d,e).....         | 197      |
| Q B7(a,b).....           | 208     | Q B10(a).....            | 24       |
| Q B7(c).....             | 59      | Q B10(b).....            | 10       |

|                          |                   |                          |                    |
|--------------------------|-------------------|--------------------------|--------------------|
| Q B10(c).....            | 131               | Q A5(d).....             | 18                 |
| Q B10(d).....            | 179               | Q A6.....                | 210                |
| Q B7(a).....             | 103               | Q B10.....               | 194                |
| Q B7(b).....             | 159               | Q B7(a,b).....           | 91                 |
| Q B7(c).....             | 135               | Q B7(c).....             | 171                |
| Q B8(a).....             | 15                | Q B8(a).....             | 230                |
| Q B8(b).....             | 131, 143, 229     | Q B8(b).....             | 65                 |
| Q B8(c).....             | 62                | Q B8(c,d,e).....         | 261                |
| Q B9(a,b).....           | 89                | Q B9(a,e).....           | 211                |
| Q B9(c).....             | 43                | Q B9(b).....             | 47                 |
| Q B9(d).....             | 251               | Q B9(c).....             | 199                |
| <b>2009 June P-2</b>     |                   | Q B9(d).....             | 115, 154           |
| Q A1(a).....             | 179               | <b>2010 June P-2</b>     |                    |
| Q A1(b).....             | 10                | Q A1(a,b,c).....         | 212                |
| Q A1(c).....             | 144               | Q A1(d).....             | 155                |
| Q A1(d,e).....           | 132               | Q A1(e).....             | 132                |
| Q A2.....                | 36                | Q A1(f).....             | 230                |
| Q A3.....                | 90                | Q A2(a,b).....           | 25                 |
| Q A4.....                | 24                | Q A2(c,d).....           | 172                |
| Q A5(a).....             | 47                | Q A3(a,b,c,d).....       | 115                |
| Q A5(b).....             | 43                | Q A3(e).....             | 65                 |
| Q A6(a).....             | 154               | Q A4.....                | 92                 |
| Q A6(b).....             | 144               | Q A5(a,b).....           | 230                |
| Q A6(c).....             | 63                | Q A5(c,d,e).....         | 240                |
| Q A6(d,e).....           | 10                | Q A6.....                | 261                |
| Q A7.....                | 260               | Q B10(a,b,c,d).....      | 155                |
| Q B10(a).....            | 64                | Q B10(b).....            | 66                 |
| Q B10(b).....            | 210               | Q B7(a).....             | 213                |
| Q B10(c).....            | 154               | Q B7(b,c).....           | 103                |
| Q B11(a).....            | 132               | Q B7(d).....             | 48, 145            |
| Q B11(b).....            | 189               | Q B8(a).....             | 65                 |
| Q B11(c,d).....          | 197               | Q B8(a,b,c).....         | 252                |
| Q B8(a).....             | 224               | Q B8(d).....             | 262                |
| Q B8(b).....             | 63                | Q B9(a,d).....           | 133                |
| Q B8(c,d).....           | 209               | Q B9(b).....             | 135                |
| Q B9(a).....             | 224               | Q B9(c,d).....           | 65                 |
| Q B9(b,c).....           | 239               | <b>2010 November P-2</b> |                    |
| Q B9(d).....             | 63                | Q A1(a).....             | 172, 180, 195, 197 |
| <b>2009 November P-2</b> |                   | Q A1(b).....             | 183                |
| Q A1(a).....             | 10, 144, 210, 230 | Q A2.....                | 240                |
| Q A1(b,c).....           | 43                | Q A3.....                | 117                |
| Q A2(a,b).....           | 239               | Q A4(a,b,c).....         | 172                |
| Q A2(c,d).....           | 114               | Q A4(c).....             | 11                 |
| Q A3(a).....             | 210               | Q A4(d).....             | 145                |
| Q A3(b).....             | 25                | Q A4(e).....             | 66                 |
| Q A3(c).....             | 170               | Q A5(a,c).....           | 35                 |
| Q A3(d).....             | 64                | Q A5(b).....             | 133                |
| Q A4(a,b).....           | 145               | Q A5(b,c).....           | 213                |
| Q A4(c,d).....           | 64                | Q B6(a,b).....           | 213                |
| Q A5(a).....             | 132               | Q B6(c).....             | 241                |
| Q A5(b).....             | 11                | Q B7(a,b,c).....         | 93                 |
| Q A5(c).....             | 171               | Q B7(d).....             | 11                 |



|                          |             |                          |                    |
|--------------------------|-------------|--------------------------|--------------------|
| Q B7(e).....             | 66          | Q B9(a).....             | 146                |
| Q B8(a).....             | 145, 189    | Q B9(b).....             | 183                |
| Q B8(b).....             | 155         | Q B9(c).....             | 133                |
| Q B8(c,d).....           | 189         | Q B9(d).....             | 156                |
| Q B9.....                | 161         |                          |                    |
| <b>2011 June P-2</b>     |             | <b>2012 June P-2</b>     |                    |
| Q A1(a,b,c).....         | 11          | Q A1(a,c,d,e,f).....     | 27                 |
| Q A1(d).....             | 190         | Q A1(b).....             | 94                 |
| Q A2.....                | 224         | Q A2(a,b).....           | 12                 |
| Q A3(a,b,c).....         | 231         | Q A2(c).....             | 70                 |
| Q A3(d).....             | 67          | Q A3(a).....             | 193                |
| Q A3(e).....             | 213         | Q A3(b,c,d).....         | 263                |
| Q A4(a,c,d).....         | 173         | Q A3(e).....             | 37                 |
| Q A4(b,e).....           | 26, 48, 214 | Q A4(a,b,d).....         | 200                |
| Q A4(d).....             | 43          | Q A4(c).....             | 201                |
| Q A5.....                | 37          | Q A4(e).....             | 49                 |
| Q A6.....                | 262         | Q A5(a,b,c).....         | 72                 |
| Q B10(a,b,c).....        | 241         | Q A5(c,d).....           | 70                 |
| Q B10(c).....            | 68          | Q B6(a,b,e).....         | 105                |
| Q B7(a,b).....           | 104         | Q B6(c).....             | 73                 |
| Q B7(c).....             | 67          | Q B6(d).....             | 120                |
| Q B7(d).....             | 118         | Q B7(a,c).....           | 73                 |
| Q B8(a,b).....           | 145         | Q B7(b).....             | 191                |
| Q B8(c).....             | 67, 119     | Q B7(d).....             | 44, 196            |
| Q B8(d).....             | 12          | Q B7(d,e).....           | 156                |
| Q B9(a,b,c).....         | 190         | Q B8.....                | 231                |
| Q B9(b).....             | 93          | Q B9(a).....             | 121                |
| Q B9(d).....             | 193         | Q B9(b).....             | 136                |
|                          |             | Q B9(c).....             | 73                 |
| <b>2011 November P-2</b> |             | Q B9(d,e).....           | 241                |
| Q A1(a).....             | 146         | <b>2012 November P-2</b> |                    |
| Q A1(b).....             | 180         | Q A1(a).....             | 38                 |
| Q A1(c,d).....           | 173         | Q A1(b).....             | 146, 191, 215, 242 |
| Q A1(e).....             | 94          | Q A1(c).....             | 49                 |
| Q A1(f).....             | 195         | Q A2(a).....             | 191                |
| Q A2(a,b,e).....         | 214         | Q A2(a,b).....           | 197                |
| Q A2(c).....             | 48          | Q A2(b).....             | 27                 |
| Q A2(d).....             | 43          | Q A3(a,b).....           | 121                |
| Q A3(a,b,c).....         | 225         | Q A3(b).....             | 106                |
| Q A3(d).....             | 69          | Q A4.....                | 242                |
| Q A3(e).....             | 214         | Q A5(a).....             | 49                 |
| Q A4(a).....             | 12, 104     | Q A5(a,b,c).....         | 94                 |
| Q A4(b,c).....           | 215         | Q A5(d).....             | 183                |
| Q A5(a,b,c).....         | 26          | Q B6(a).....             | 147                |
| Q A5(c).....             | 19          | Q B6(a,b).....           | 173                |
| Q A5(d).....             | 69, 173     | Q B6(a,c).....           | 134                |
| Q B6(a,b).....           | 160         | Q B6(d).....             | 74                 |
| Q B6(c,d).....           | 200         | Q B7(a).....             | 38                 |
| Q B7(a).....             | 146         | Q B7(b).....             | 20                 |
| Q B7(b,c).....           | 94          | Q B7(c).....             | 44                 |
| Q B7(d).....             | 69, 120     | Q B8(a,b,c,d).....       | 147                |
| Q B8(a,b,c).....         | 252         | Q B8(c).....             | 74                 |
| Q B8(c).....             | 69          | Q B9(a).....             | 174, 201           |

|                          |          |                          |          |
|--------------------------|----------|--------------------------|----------|
| Q B9(b,c).....           | 264      | Q B8(a).....             | 136      |
| Q B9(d).....             | 147      | Q B8(b).....             | 77, 124  |
| <b>2013 June P-2</b>     |          | Q B8(c).....             | 107      |
| Q A1(a,c,e,f).....       | 174      | Q B8(d).....             | 13       |
| Q A1(b).....             | 12       | Q B9(a,b,c).....         | 148      |
| Q A1(d).....             | 38       | Q B9(d).....             | 77       |
| Q A2(a,b).....           | 215      | Q B9(e).....             | 156      |
| Q A2(c).....             | 106      | <b>2014 June P-2</b>     |          |
| Q A3(a).....             | 174      | Q A1(a).....             | 196      |
| Q A3(b).....             | 20       | Q A1(b,c).....           | 216      |
| Q A3(c).....             | 49       | Q A1(d).....             | 227      |
| Q A3(d).....             | 232      | Q A2(a,c).....           | 78       |
| Q A3(e).....             | 198      | Q A2(b).....             | 149      |
| Q A4.....                | 226      | Q A3(a,b,d,e).....       | 265      |
| Q A5(a).....             | 74       | Q A3(c).....             | 16       |
| Q A5(b).....             | 175      | Q A4.....                | 96       |
| Q A5(c).....             | 13       | Q A5(a).....             | 196      |
| Q A5(d).....             | 134      | Q A5(b,c).....           | 184      |
| Q A5(e).....             | 122      | Q A5(d).....             | 134      |
| Q A6(a,c).....           | 134      | Q A6.....                | 14       |
| Q A6(b).....             | 75       | Q B10(a).....            | 28       |
| Q A6(d).....             | 192      | Q B10(b).....            | 50       |
| Q B10(a).....            | 44       | Q B10(c).....            | 45       |
| Q B10(b).....            | 95       | Q B10(c,d).....          | 175      |
| Q B10(c).....            | 13, 76   | Q B10(d).....            | 125      |
| Q B7(a,c).....           | 122      | Q B7(a,b,c,d).....       | 233      |
| Q B7(b).....             | 75, 148  | Q B7(d).....             | 78       |
| Q B8.....                | 244      | Q B8(a,d,e).....         | 244      |
| Q B9(a).....             | 107, 123 | Q B8(b).....             | 14       |
| Q B9(b,c).....           | 136      | Q B8(c).....             | 79       |
| Q B9(d).....             | 76       | Q B9(a).....             | 108      |
| <b>2013 November P-2</b> |          | Q B9(b).....             | 124      |
| Q A1(a).....             | 95       | Q B9(c).....             | 136      |
| Q A1(b).....             | 180      | Q B9(d).....             | 79       |
| Q A1(c,e,f).....         | 175      | Q B9(e).....             | 196      |
| Q A1(d).....             | 192      | <b>2014 November P-2</b> |          |
| Q A2.....                | 253      | Q A1(a).....             | 14       |
| Q A3(a,b).....           | 28       | Q A1(a,b).....           | 149, 176 |
| Q A3(c,d).....           | 175      | Q A2(a,b,d).....         | 176      |
| Q A3(d).....             | 50       | Q A2(b).....             | 108      |
| Q A3(e).....             | 39       | Q A2(c).....             | 150      |
| Q A4(a,b).....           | 216      | Q A2(d).....             | 184      |
| Q A4(c,d).....           | 148      | Q A3(a,b).....           | 16       |
| Q A5(a).....             | 148      | Q A3(b,c).....           | 79       |
| Q A5(b).....             | 123      | Q A4(a,c).....           | 150      |
| Q A5(c).....             | 76       | Q A4(b).....             | 79, 125  |
| Q B6(a).....             | 96       | Q A4(d).....             | 216      |
| Q B6(b,c).....           | 198      | Q A5(a).....             | 192      |
| Q B6(c).....             | 77       | Q A5(b,c).....           | 97       |
| Q B7(a,b,c).....         | 232      | Q B6(a,b,c).....         | 45       |
| Q B7(c).....             | 265      | Q B6(d).....             | 98       |
| Q B7(d).....             | 77       | Q B6(e).....             | 150      |

|                          |         |                      |     |
|--------------------------|---------|----------------------|-----|
| Q B7(a,b,c,d).....       | 245     | Q B10.....           | 126 |
| Q B7(e).....             | 80, 150 | Q B7(a,b,c,d,e)..... | 39  |
| Q B8(a).....             | 81, 126 | Q B7(f).....         | 198 |
| Q B8(b,c).....           | 156     | Q B7(g,h).....       | 30  |
| Q B9(a,b,c,d).....       | 137     | Q B8(a).....         | 82  |
| Q B9(e).....             | 81      | Q B8(b,c).....       | 177 |
| <b>2015 June P-2</b>     |         | Q B9.....            | 236 |
| Q A1(a).....             | 217     | <b>2016 June P-2</b> |     |
| Q A1(a,b).....           | 255     | Q A1.....            | 266 |
| Q A2(a).....             | 177     | Q A2(a,b,d).....     | 46  |
| Q A2(b).....             | 108     | Q A2(c).....         | 82  |
| Q A2(c).....             | 137     | Q A3.....            | 255 |
| Q A2(d).....             | 156     | Q A4(a,b,c).....     | 161 |
| Q A3.....                | 29      | Q A4(d).....         | 82  |
| Q A4.....                | 151     | Q A5(a,b,c,d).....   | 30  |
| Q A5.....                | 98      | Q A5(e).....         | 180 |
| Q B6.....                | 152     | Q A6(a).....         | 50  |
| Q B7.....                | 184     | Q A6(b,c,d).....     | 217 |
| Q B8.....                | 233     | Q B10(a).....        | 135 |
| Q B9.....                | 235     | Q B10(b,c).....      | 127 |
| <b>2015 November P-2</b> |         | Q B10(d,e).....      | 157 |
| Q A1.....                | 164     | Q B7(a,b,d).....     | 152 |
| Q A2.....                | 246     | Q B7(c).....         | 99  |
| Q A3.....                | 201     | Q B8(a,b,c,e).....   | 237 |
| Q A4.....                | 185     | Q B8(d,e).....       | 83  |
| Q A5.....                | 20      | Q B9(a,b).....       | 109 |
| Q A6.....                | 81      | Q B9(c).....         | 138 |