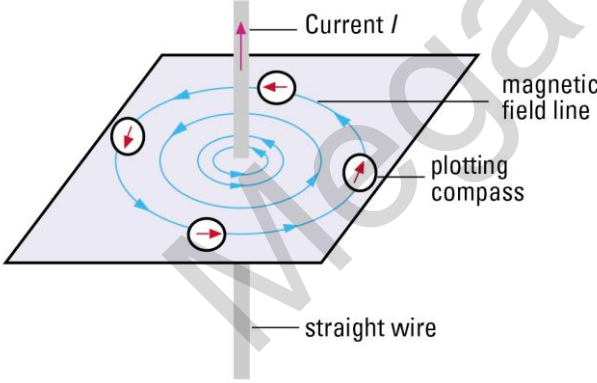
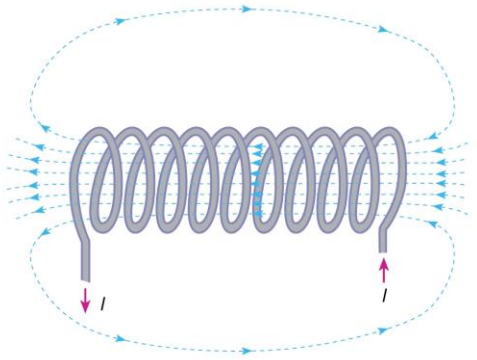
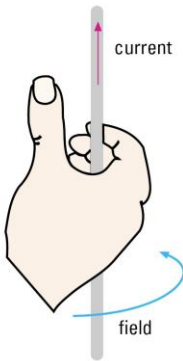
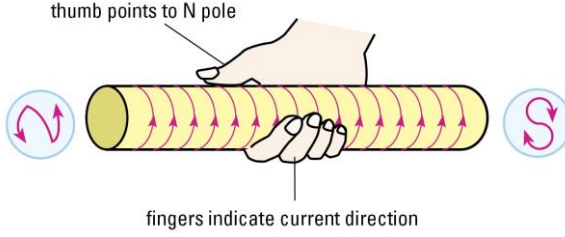

Chapter 21 Electromagnetism

- (a) draw the pattern of the magnetic field due to currents in straight wires and in solenoids and state the effect on the magnetic field of changing the magnitude and/or direction of the current
- (b) describe the application of the magnetic effect of a current in a circuit breaker
- (c) describe experiments to show the force on a current-carrying conductor, and on a beam of charged particles, in a magnetic field, including the effect of reversing
 - (i) the current
 - (ii) the direction of the field
- (d) deduce the relative directions of force, field and current when any two of these quantities are at right angles to each other using Fleming's left-hand rule
- (e) describe the field patterns between currents in parallel conductors and relate these to the forces which exist between the conductors (excluding the Earth's field)
- (f) explain how a current-carrying coil in a magnetic field experiences a turning effect and that the effect is increased by increasing
 - (i) the number of turns on the coil
 - (ii) the current
- (g) discuss how this turning effect is used in the action of an electric motor
- (h) describe the action of a split-ring commutator in a two-pole, single-coil motor and the effect of winding the coil on to a soft-iron cylinder

(a) Magnetic field patterns due to currents in straight wires and in solenoids

Recall: Use the **right hand grip rule** to determine direction of magnetic field/magnetic poles on a solenoid

| Magnetic field due to currents in straight wire | Magnetic field due to current in solenoid |
|---|--|
|  |  |
|  |  |

Effect of reversing direction of current and increasing current strength

Top View of currents

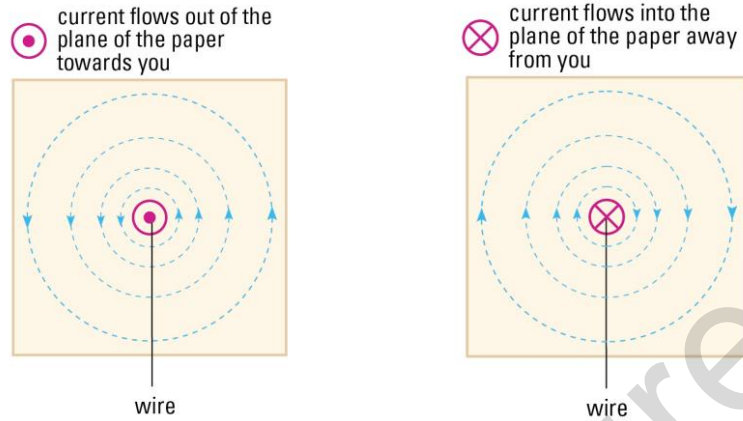

Strength of a magnetic field around a current carrying wire depends on:

- ❖ The **strength** of the current and the **distance** from the wire.
- ❖ Take note that the **spacing between consecutive circles increases**, this shows that the magnetic weakens as distance increases

Magnetic field of a solenoid and a single loop

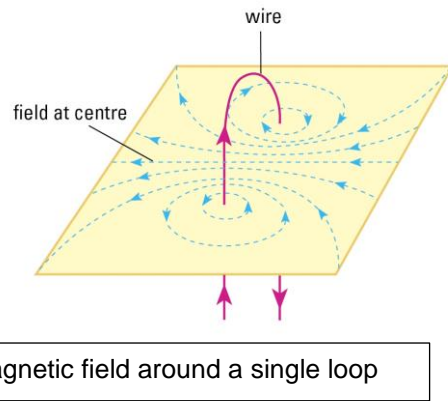
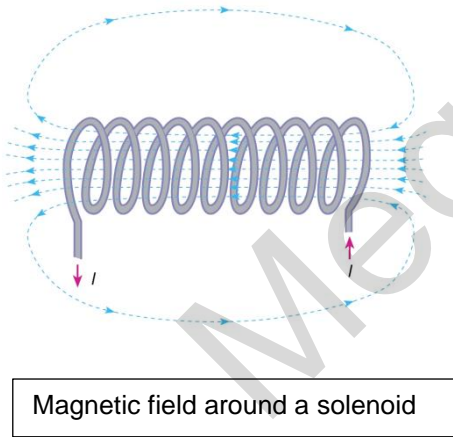

Determine the direction of the magnetic field inside outside each of the following diagrams. Use a 'dot' or 'cross' to represent the direction of the field.

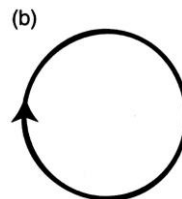
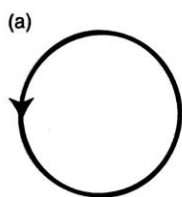

Draw the magnetic field pattern around and inside the solenoids.

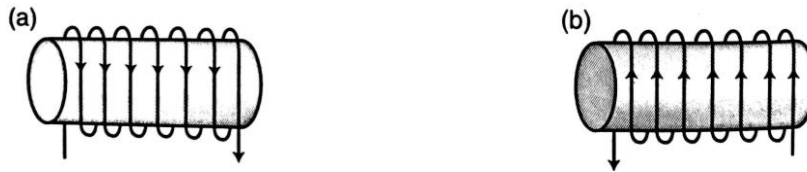

(b) Describe how the circuit breaker works

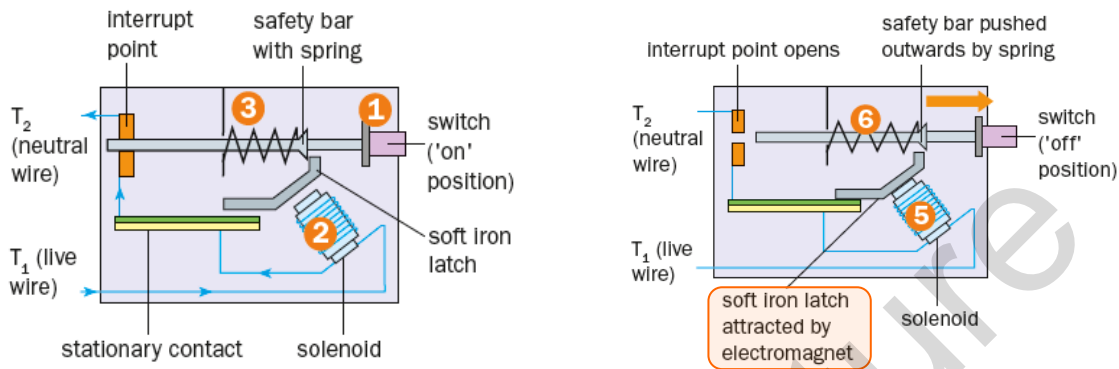

(c) Describe experiments that shows force on (i) current carrying conductor in a magnetic field (ii) moving charged particles in a magnetic field (Motor Effect)

(i) Current carrying conductor

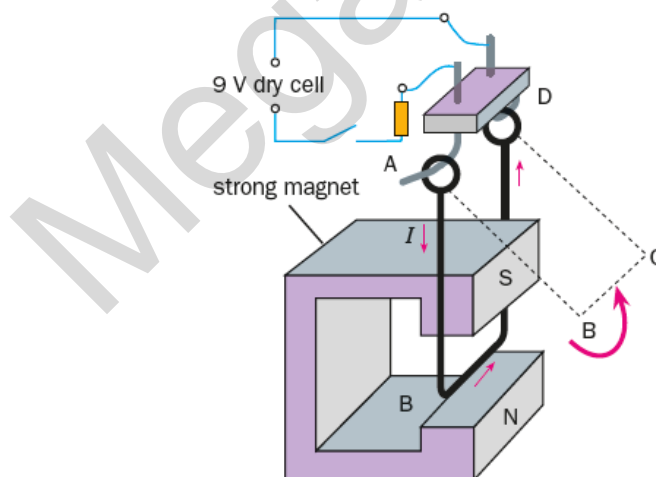

- A **force** is exerted on a **current carrying conductor** when it is placed **perpendicular** to a magnetic field.
- The magnetic field set up by the current in the wire **interacts** with the magnetic field of the permanent magnet, causing a force to be exerted on the wire.

(ii) Force on a beam of charged particles in a magnetic field (replace current carrying conductor with a moving charged particle)

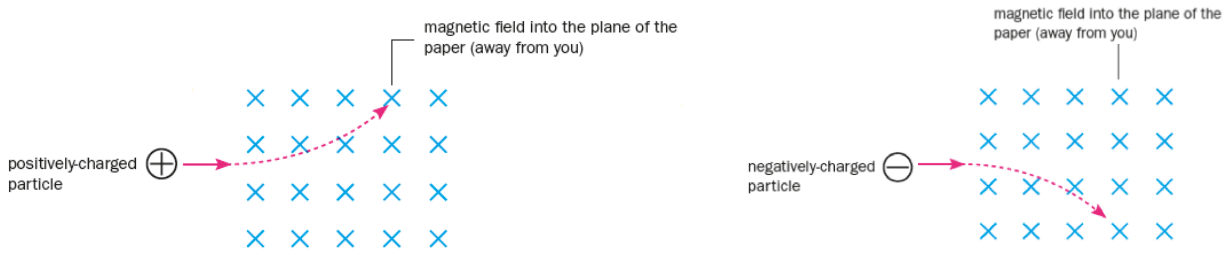

(d) Deducing direction of force, current and magnetic field – use Fleming's Left Hand rule

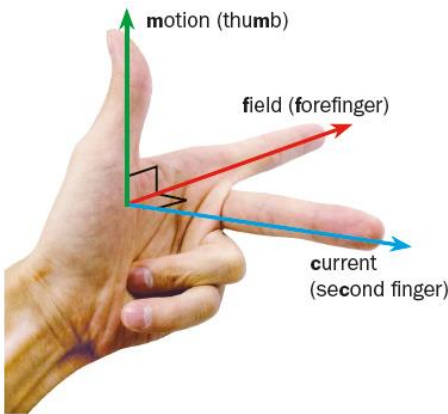

Fleming's left hand rule shows that when a current (second finger) is perpendicular to the magnetic field it is placed in (first finger), a force is exerted on the current carrying conductor (thumb)

Predict the direction of the force acting on each charge moving through the magnetic fields as shown.

Using a catapult field to illustrate the motor effect

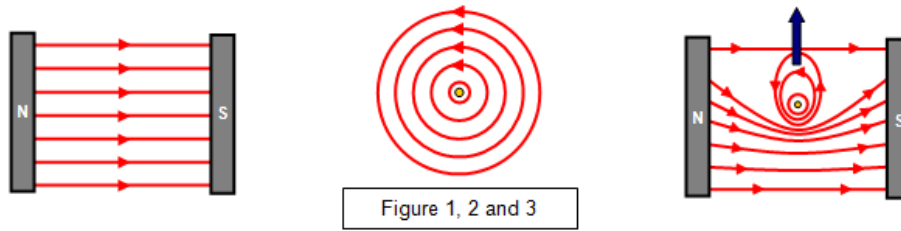
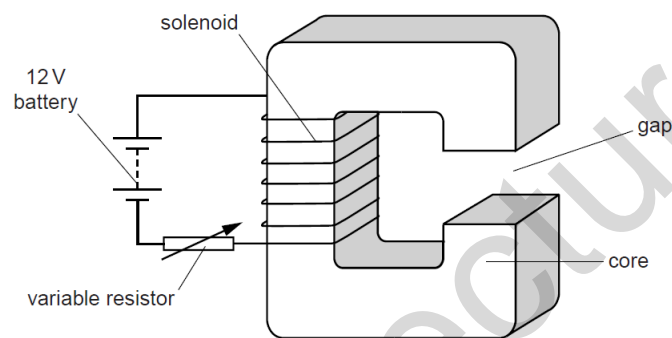

Figure 1, 2 and 3

The **closely packed** magnetic field lines below the wire in Fig 3 indicates that the magnetic field in that region is stronger. Therefore, a **net upward force** will be exerted on the wire

Question 1

(a) A wire is wound around a soft-iron core forming a solenoid, as shown in the figure.



There is a gap in the core. The solenoid is connected in series with a 12 V battery and a variable resistor. The resistance of the solenoid is 0.30Ω and the variable resistor is set so that it has a resistance of 4.5Ω .

- (i) Calculate the current in the solenoid.
- (ii) The current in the solenoid magnetises the soft-iron core. Explain how the electric circuit is used to increase the strength of the magnetic field.
- (iii) The figure below shows a horizontal, current-carrying wire PQ in the gap.

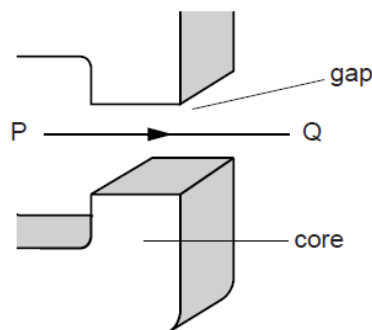

1. The magnetic field in the gap is uniform and vertically upwards. The current in PQ is from left to right. Describe the effect of the magnetic field on PQ.
2. State the effect on PQ of increasing the strength of the magnetic field in the gap.

- (b) The starter motor in a car is powered by a 12 V battery that is positioned next to the motor. The current in the motor is 75 A.
- Calculate the power supplied by the battery.
 - Suggest and explain why the wires that connect the motor to the battery are very thick.

Question 2

The figure shows the coil of a loudspeaker attached to a cardboard cone. One pole of a stationary cylindrical magnet lies near to the coil.

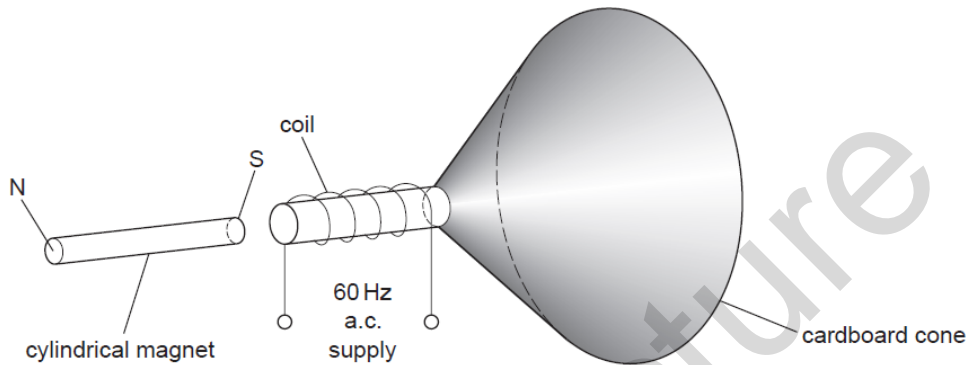

There is an alternating current in the coil of the loudspeaker. A student hears the note produced.

- Explain why the cone of the loudspeaker vibrates.
 - Explain how the vibrating cone produces sound waves in the air.
- A stronger cylindrical magnet is now used. State the difference in the note heard.

Motor effect and Loudspeaker

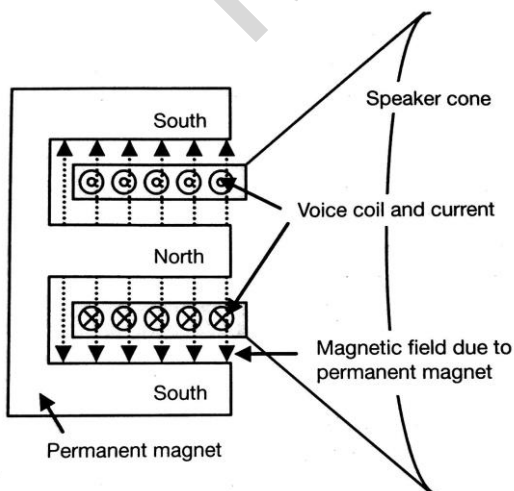

Current through coil produces a changing magnetic field

This magnetic field interacts with the magnetic field of the permanent magnet causing a force to act on the cone

As the alternating current in the coil changes direction and magnitude, the speaker cone moves back and forth

The loudness of the sound depends on the current

The pitch of the sound depends on the frequency of the alternating current

(e) Force exerted on parallel current carrying conductors

Magnetic field of one conductor interacts with the magnetic field of the other conductor, causing a **force** to be **exerted** on both conductors (Newton's third law)

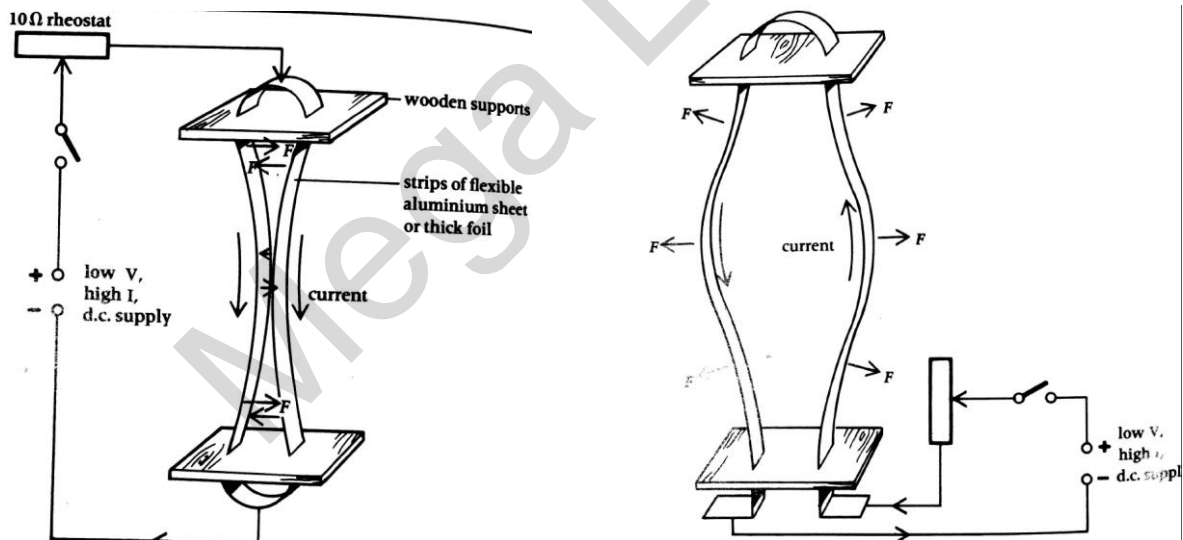
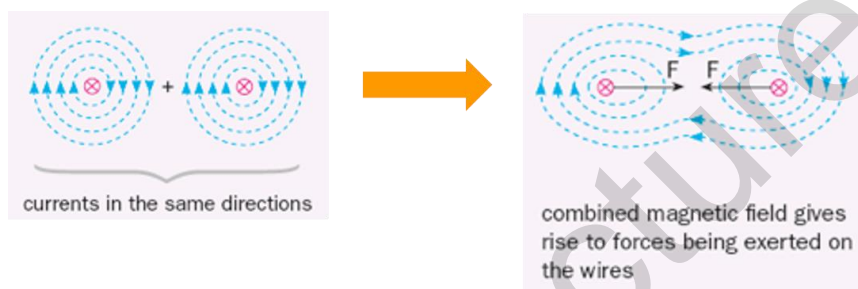
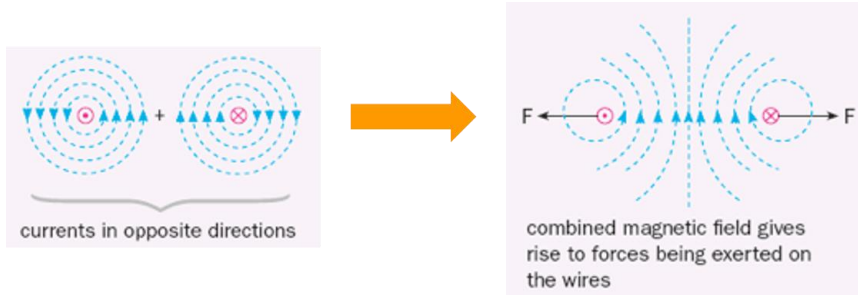

The direction of the force between parallel current-carrying conductors is:

- Repulsive if the currents are in opposite directions
- Attractive if the currents are in the same direction

(f) Force on a current carrying coil in a magnetic field

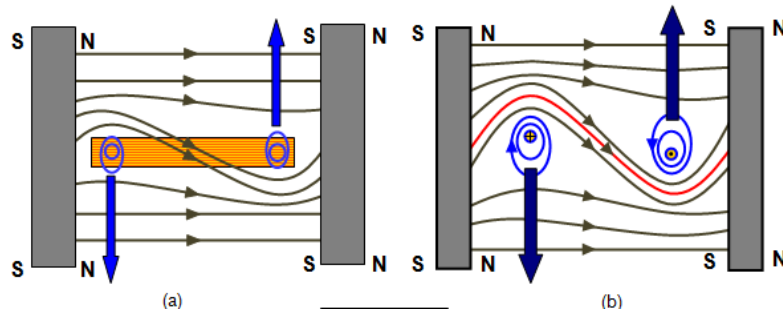

To increase the turning effect

- Increase number of turns on the coil
- Increase the magnitude of the current
- Increase the strength of the permanent magnet

(g) Electric motor (D.C. motor)

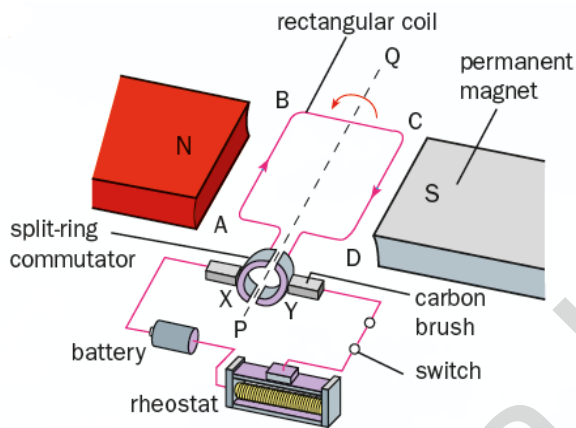

A force acts on both sides of the coil but in opposite directions because the current is in opposite directions. These two forces produce a turning effect which turns the coil anticlockwise. The centre of the coil is connected to an axle which can be used to do work e.g. spin the blades of a fan.

Motors change **electrical energy into mechanical energy** (kinetic or potential).

They consist of **magnets** fixed to the casing of the motor (stator) so they **remain stationary** and a **rotating armature** on which the **coils of wire are wound**.

When a current flows through the coils, the **interaction** between the **magnetic field** due to the **current and the fixed magnet** causes the armature to rotate. (Fleming's left hand rule)

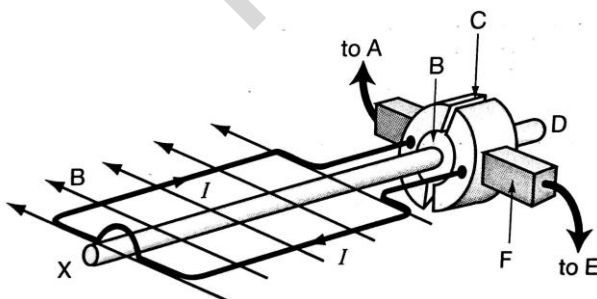

(a) Which way does the coil rotate as seen from X?
 (b) Identify the parts A to F.

(h) Action of a split ring commutator

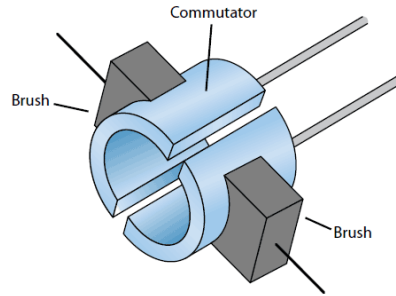

A split ring commutator acts as a switching device to change the direction of the current in the coil every half rotation so that the direction of the moment remains constant.

| | |
|---|---|
| <p>Current flows in the direction ABCD Upward force acts on D</p> | <p>Commutator and coil rotates by 90° No current flows into coil due to split in commutator</p> |
| <p>Commutator and coil continue moving due to inertia Current reverses direction and flows in the direction DCBA Downward force acts on D</p> | <p>Current flows in the direction DCBA Downward force acts on D. Direction of moment remains as anticlockwise throughout</p> |

The **turning effect** can be increased by **increasing** number of **turns** on the coil, placing a **soft iron core** in the centre of the coil, **increasing current** and using **stronger magnets (e.g. electromagnet)**

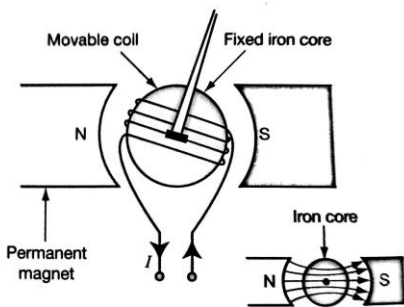

Figure 20.2 Soft iron core.

Winding the coils on a soft iron cylinder transfers the magnetic field **more efficiently** from the permanent magnet to the coils than an air core.

Extension:

(Recall: $\text{Moment} = \text{Force} \times \text{perpendicular distance}$)

$\text{Magnetic force} = BIl$ (B = magnetic field strength, I = current, l = length of coil perpendicular to magnetic field)

Formula can be simplified to $\text{Moment} = nBIA$ (n = number of turns, A = area of coil)

Question 3

The figure shows several stages in the rotation of the coil in a simple motor.

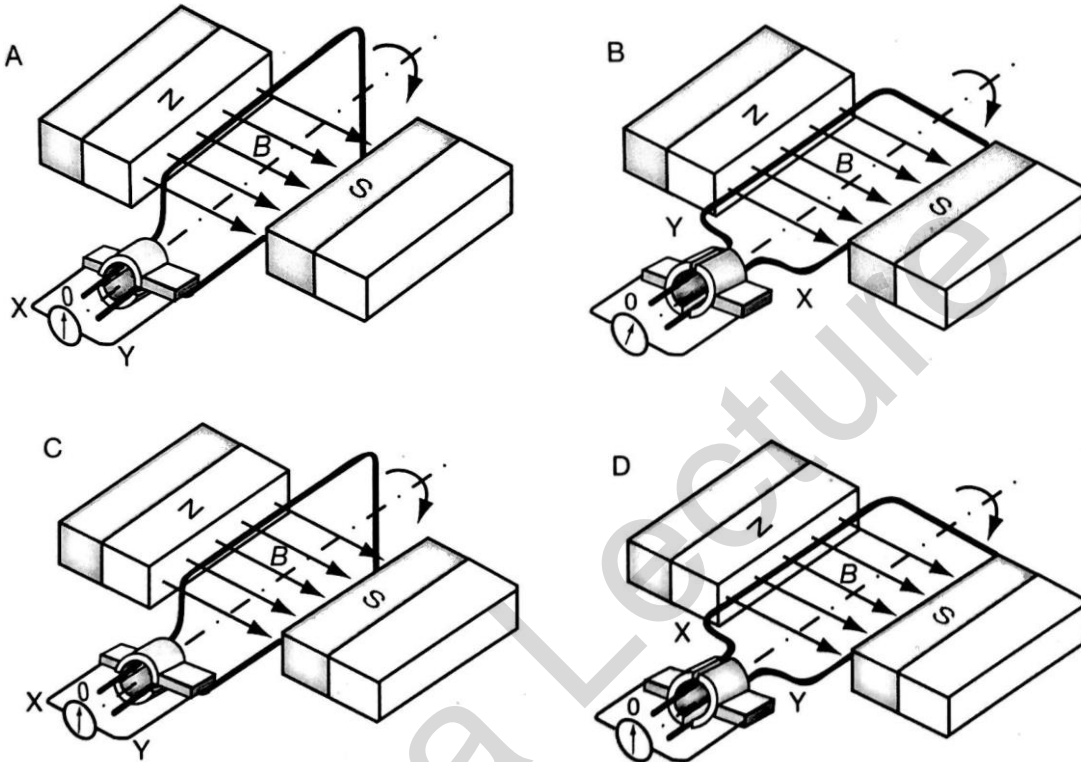

(a) Describe how the moment on the coil changes as it rotates from position A to D.

(b) Sketch a graph to represent the change in moment.

(c) At which point in the rotation of the coil must the current flowing through it change direction? Explain your answer.

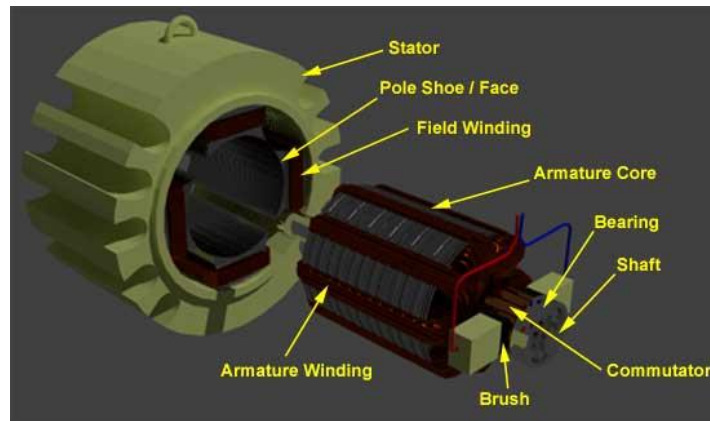

| Parts | Function |
|--------------------------------|---|
| Stator | Stationary part of motor comprising electromagnets/permanent magnet Protective covering used to house whole motor |
| Field winding | Copper wire wound on stator used to produce magnetic field if permanent magnets are not used |
| Armature core (soft iron core) | Attached to rotor (rotating part of motor) Made of iron and is used to concentrate the magnetic field to increase the turning effect |
| Armature winding | Copper wire wound on the rotor on which a force is exerted when current flows Provides the turning effect by converting electrical energy to kinetic energy Connected to the axle from which useful work is extracted (e.g. spinning a turbine or fan blades) |
| Commutator | Reverses direction of current flow every half revolution of the rotor |
| Brush | Made of graphite or carbon Makes sliding contact with commutator Supplies current from external circuit to commutator to armature winding. |

Question 4

The figure shows a type of motor. PQ and RS are solenoids. The solenoids and the coil ABCD are connected in parallel to a battery.

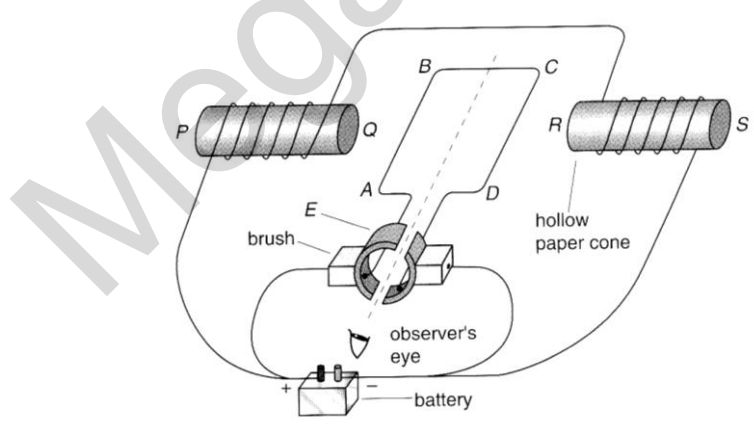

a) Explain briefly how the motor works.

b) State

- (i) the polarity at end Q of the solenoid PQ;
- (ii) the direction of current in the coil;
- (iii) the direction of rotation of the coil as seen by the observer.

c) Name the component E and explain its function.

d) The motor can be modified and converted into a simple ammeter to allow it to measure the current passing through. Suggest and explain briefly how this can be done.

e) A student says that if the battery is replaced by a 50 Hz a.c supply, the coil will only oscillate to and fro hence the motor will not function properly. Explain why the student is incorrect.

Mega Lecture