

Q1 (a) State the reagents and conditions needed to convert benzene into

(i) chlorobenzene,

.....
 (ii) bromobenzene,

.....
 (iii) nitrobenzene.

.....[4]
 (b) The nitration of benzene is a two-step reaction that can be represented as follows.

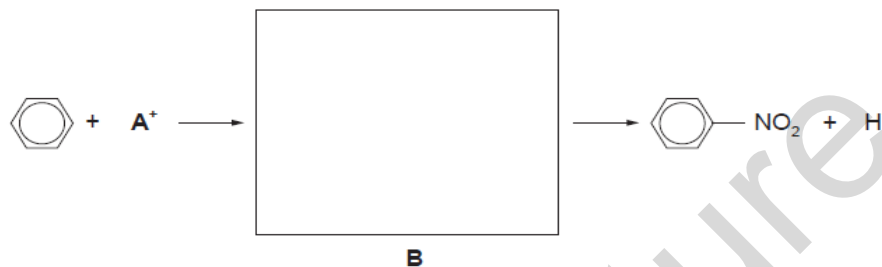

(i) Identify the cation **A+**.

(ii) Draw the structure of the intermediate **B** in the box. [2]

(c) The position of substitution during the electrophilic substitution of arenes is determined by the nature of the group already attached to the ring. Electron-withdrawing groups such as $-\text{CO}_2\text{H}$ or $-\text{NO}_2$ direct the incoming group to the 3-position.



On the other hand, electron-donating groups such as $-\text{CH}_3$ or $-\text{NH}_2$ direct the incoming group to the 2- or 4- positions.

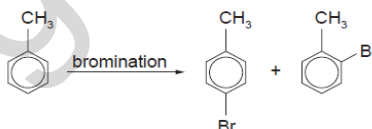

Use this information to suggest a likely structure for the organic product of each of the following reactions.

(i)

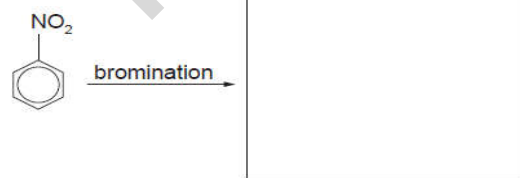

(ii)

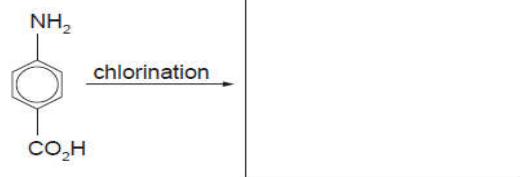

(June 2004 Q5)

Q2 The following scheme shows some reactions of methylbenzene.

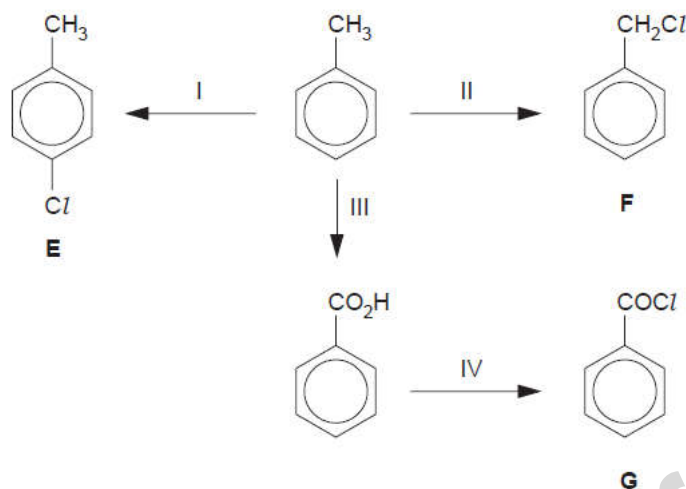

(a) Suggest reagents and conditions for reactions I to IV.

I

II

III

IV [4]

(b) What *type of reaction* is each of the following?

reaction I

reaction III

(c) Compound F can be converted into 2-phenylethylamine in a two-stage process.

Suggest a structure for the intermediate, H, in the box below, and suggest reagents and conditions for the steps V and VI.

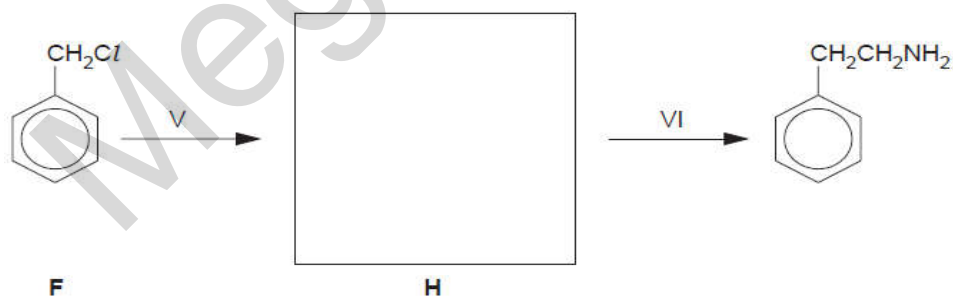

reagents and conditions for step V

reagents and conditions for step VI

(d) The compounds E, F and G react at different rates with nucleophilic reagents. Draw structures for the products of each compound with the following reagents. If no reaction occurs, write "**no reaction**" in the box.

compound	reagent	
	cold water	hot NaOH(aq)
E		
F		
G		

(June 2007 Q5)

Q3

The substituted benzene compound



can be further substituted.

If Y is an electron-withdrawing group, the next substitution will be in position 3.

If Y is an electron-releasing group, the next substitution will be mostly in position 4.

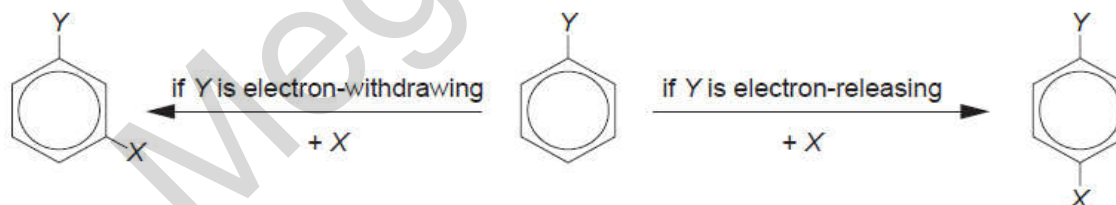

The following table lists some electron-withdrawing and electron-releasing substituents.

electron-withdrawing groups	electron-releasing groups
-NO ₂	-CH ₃
-COCH ₃	-CH ₂ Br
-CO ₂ H	-NH ₂

Use the above information to draw relevant structural formulae in the boxes in the schemes below.

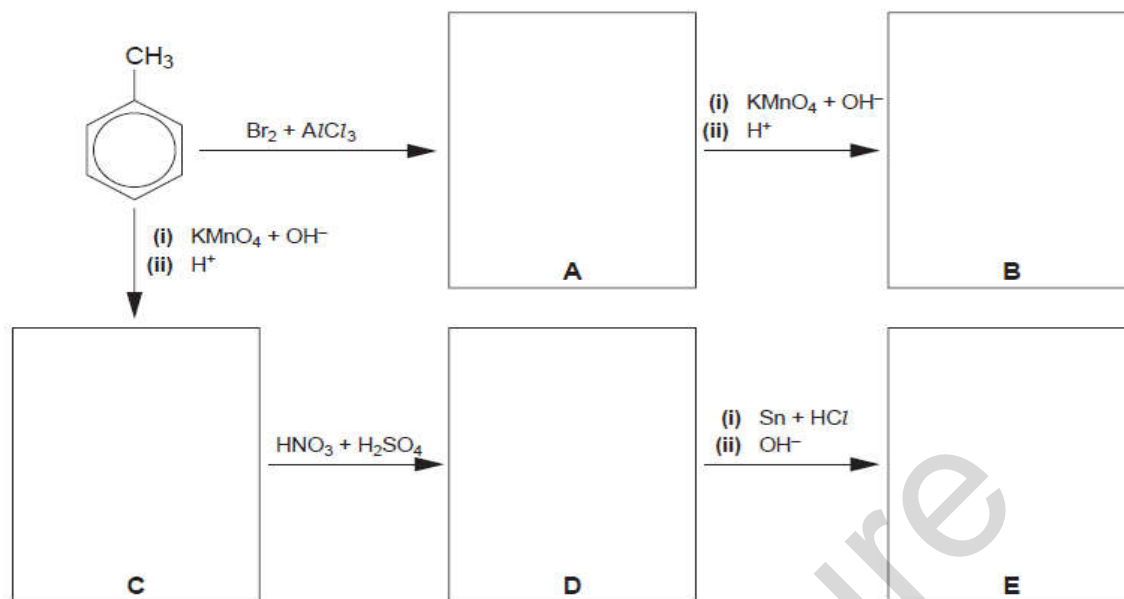

(June 2008 Q6)

Q4 Predict the products of the following reactions and draw their structures in the boxes provided. Note that the molecular formula of the final product is given in each case.

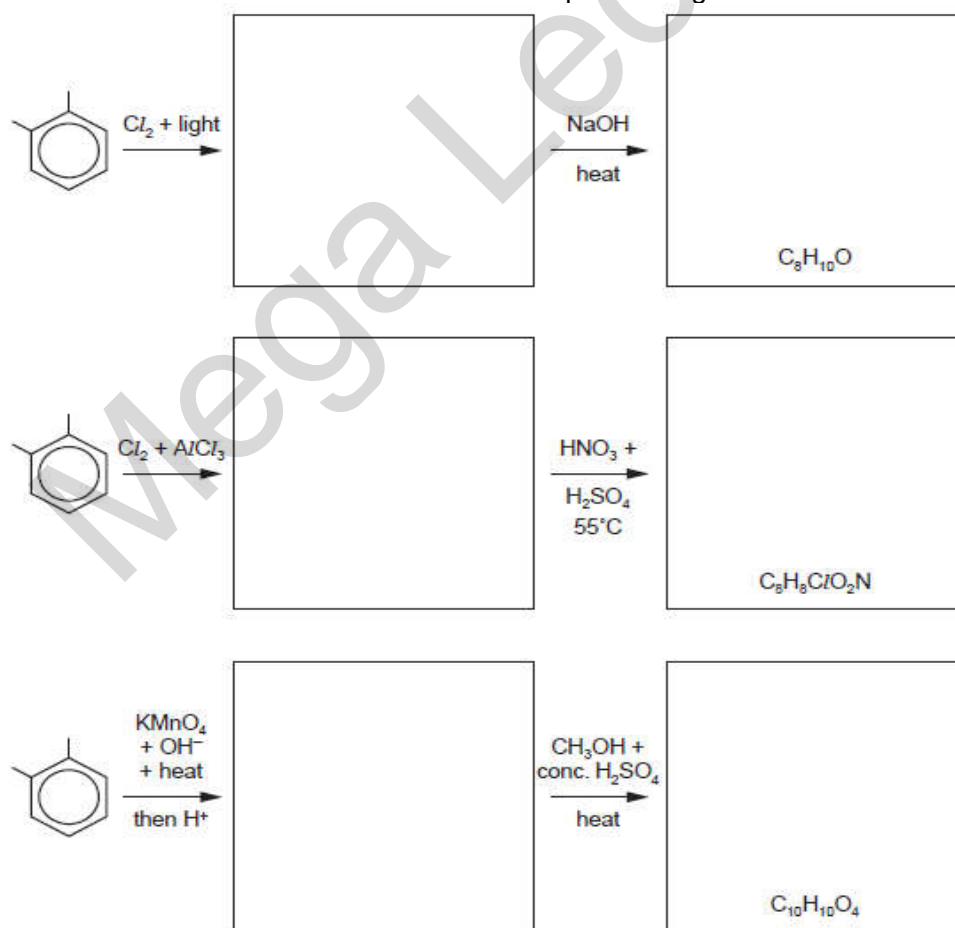

(June 2010 P41 Q7)

Q5 (a) (i) Briefly explain why the benzene molecule is planar.

.....
.....
.....

(ii) Briefly explain why all the carbon-carbon bonds in benzene are the same length.

.....
.....
.....

(b) Benzene can be nitrated by warming it with a mixture of concentrated sulfuric and nitric acids.

(i) By means of an equation, illustrate the initial role of the sulfuric acid in this reaction.

(ii) Name the type of reaction and describe the mechanism for the nitration reaction, including curly arrows showing the movement of electrons and all charges.

type of reaction
mechanism

(c) State the reagents and conditions needed to convert benzene into chlorobenzene.

(d) Nitrobenzene undergoes further substitution considerably more slowly than chlorobenzene.

In nitrobenzene the incoming group joins to the benzene ring in the 3-position, whereas in chlorobenzene the incoming group joins to the benzene ring in the 4-position.

(i) Use these ideas to suggest the structures of the intermediate compounds **Y** and **Z** in the following synthesis of 4-chlorophenylamine.

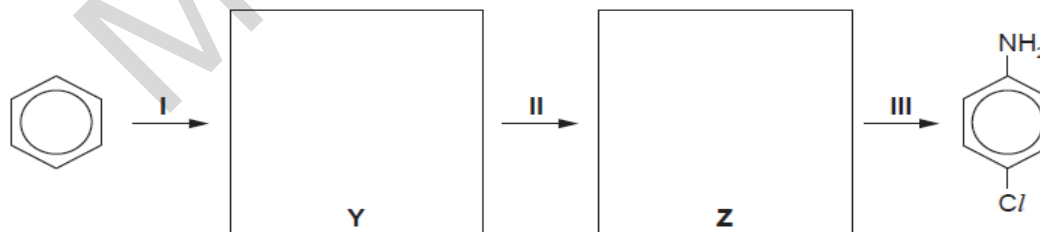

(ii) Suggest the reagents and conditions needed for reaction III in the above synthesis.

.....
.....

(iii) Suggest the structural formulae of the products **A**, **B**, **C** and **D** of the following reactions. If no reaction occurs write "no reaction" in the relevant box.

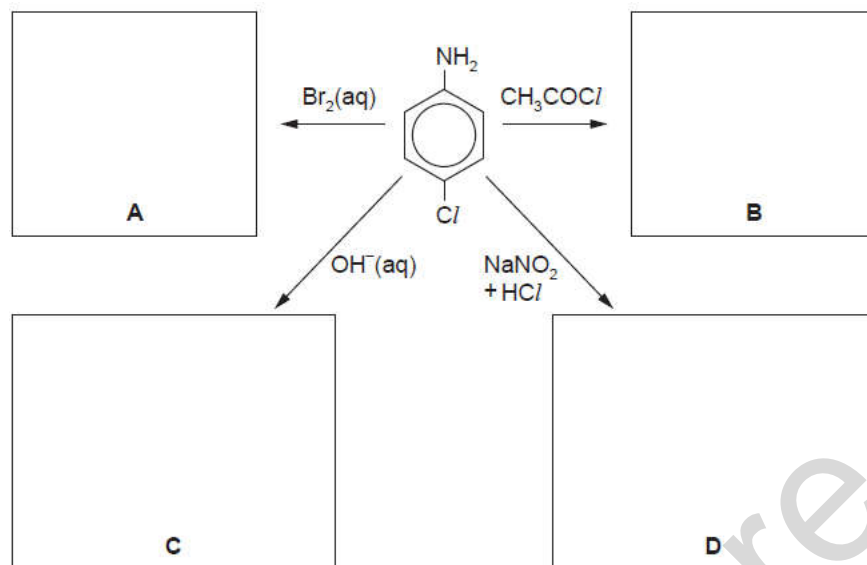

(June 2010 P42 Q5)

Q6 (a) There are several ways of introducing chlorine atoms into organic molecules. State the reagents and conditions necessary to carry out the following transformations.

transformation	reagents + conditions
$\text{C}_2\text{H}_4 \longrightarrow \text{C}_2\text{H}_5\text{Cl}$	
$\text{C}_2\text{H}_5\text{OH} \longrightarrow \text{C}_2\text{H}_5\text{Cl}$	
$\text{C}_2\text{H}_6 \longrightarrow \text{C}_2\text{H}_5\text{Cl}$	
$\text{C}_2\text{H}_4 \longrightarrow \text{C}_2\text{H}_4\text{Cl}_2$	
$\text{CH}_3\text{CO}_2\text{H} \longrightarrow \text{CH}_3\text{COCl}$	
\longrightarrow	
\longrightarrow	

(b) (i) When treated with concentrated $\text{HNO}_3 + \text{H}_2\text{SO}_4$ at 55°C , benzene produces nitrobenzene. Outline the mechanism of this reaction. You should include all charges, and use curly arrows to represent the movement of electron pairs.

In aromatic substitution of monosubstituted benzenes, the orientation of an incoming group depends on the nature of the group already attached to the ring.
For example, using the same reagents and conditions as in (i), methylbenzene and benzoic acid produce the following nitro compounds.

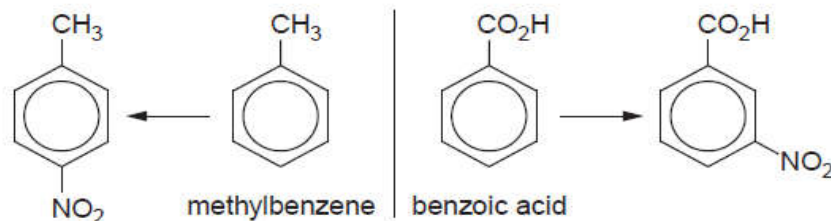

(ii) Using this information as an aid, suggest a structure for compound **C** in the following synthesis of 3-bromobenzoic acid.

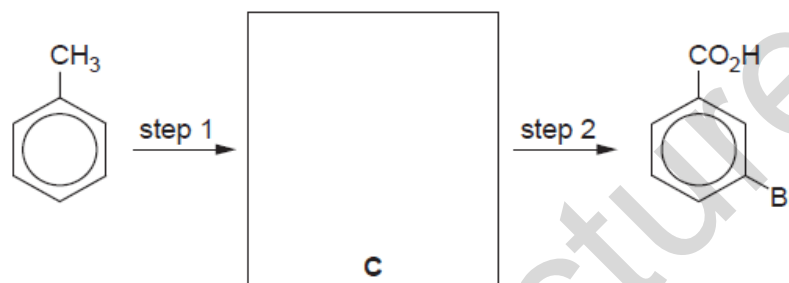

(iii) Suggest reagents and conditions for steps 1 and 2.

step 1

step 2

(June 2011 P41 Q5)