

# Physical Quantities, Units and Measurements

## Question Paper

Level	O Level
Subject	Physics
Exam Board	Cambridge International Examinations
Unit	General Physics
Topic	Physical Quantities, Units and Measurements
Booklet	Question Paper

**Time Allowed:** 70 minutes

**Score:** /58

**Percentage:** /100

**Grade Boundaries:**

**Save My Exams! – The Home of Revision**

For more awesome GCSE and A level resources, visit us at [www.savemyexams.co.uk/](http://www.savemyexams.co.uk/)

- 1 The diagram shows arrows representing two vector quantities.



Which diagram shows the resultant  $R$  of these two vectors?

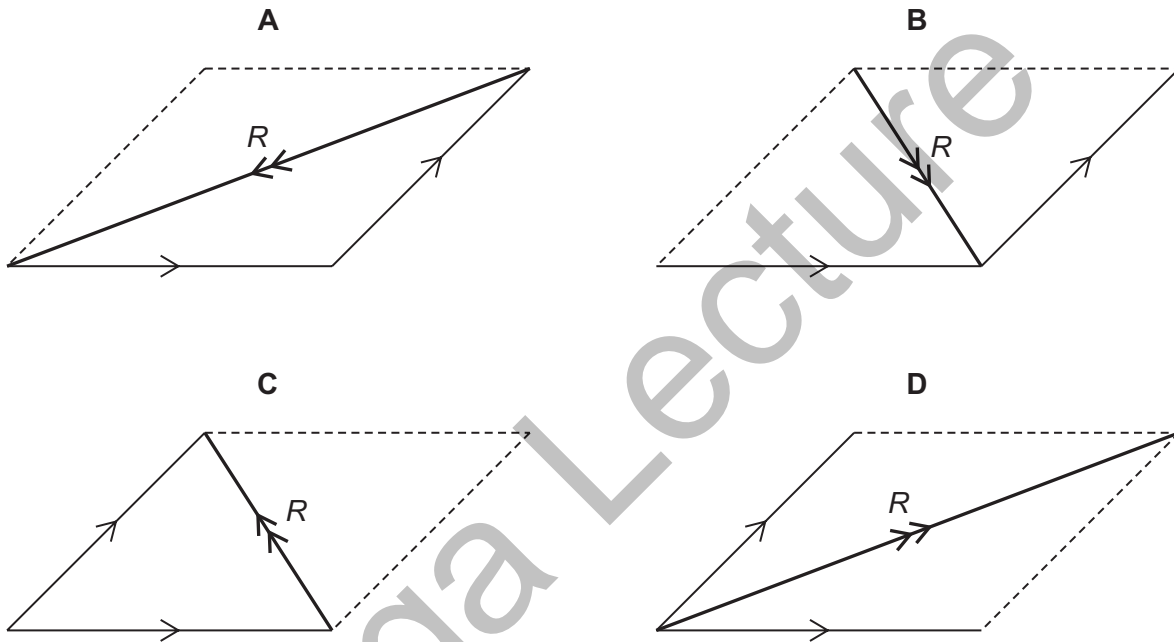

- 2 Which set of quantities are all vectors?
- A acceleration, displacement, velocity
  - B chemical energy, mass, power
  - C extension, force, gravitational potential energy
  - D weight, kinetic energy, work

Save My Exams! – The Home of Revision

For more awesome GCSE and A level resources, visit us at [www.savemyexams.co.uk/](http://www.savemyexams.co.uk/)

- 3 A student determines the circumference of a golf ball.

Which instrument gives a reading that is the circumference of the golf ball?

- A calipers
- B micrometer
- C rule
- D tape

- 4 Which quantity is a vector?

- A energy
- B force
- C speed
- D time

- 5 Is mass a scalar or a vector, and is acceleration a scalar or a vector?

	mass	acceleration
A	scalar	scalar
B	scalar	vector
C	vector	scalar
D	vector	vector

- 6 The diameter and the length of a thin wire, approximately 50 cm in length, are measured as precisely as possible.

What are the best instruments to use?

	diameter	length
A	micrometer	rule
B	micrometer	vernier calipers
C	rule	tape
D	vernier calipers	rule

**Save My Exams! – The Home of Revision**

For more awesome GCSE and A level resources, visit us at [www.savemyexams.co.uk/](http://www.savemyexams.co.uk/)

- 7 Newton's third law involves two quantities which are equal in size and opposite in direction.

What is the unit for these two quantities?

- A J
- B  $\text{m/s}^2$
- C N
- D W

- 8 Which quantity is a scalar?

- A acceleration
- B force
- C temperature
- D velocity

- 9 During an experiment to find the density of a stone, the stone is lowered into a measuring cylinder partly filled with water.

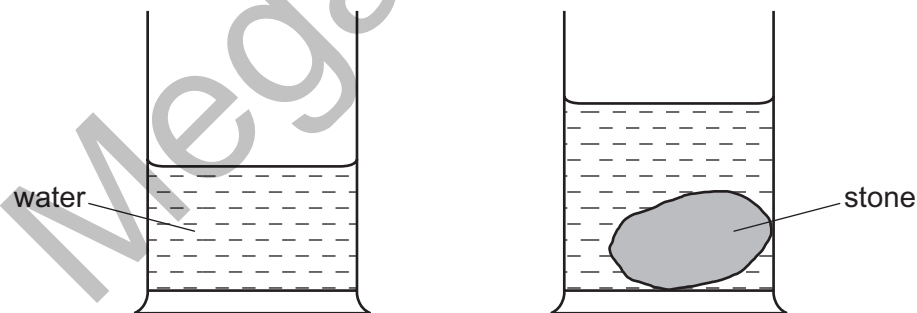

Which statement is correct?

- A The difference between the readings gives the density of the stone.
- B The difference between the readings gives the volume of the stone.
- C The final reading gives the density of the stone.
- D The final reading gives the volume of the stone.

Save My Exams! – The Home of Revision

For more awesome GCSE and A level resources, visit us at [www.savemyexams.co.uk/](http://www.savemyexams.co.uk/)

10 The diagram shows a micrometer scale.

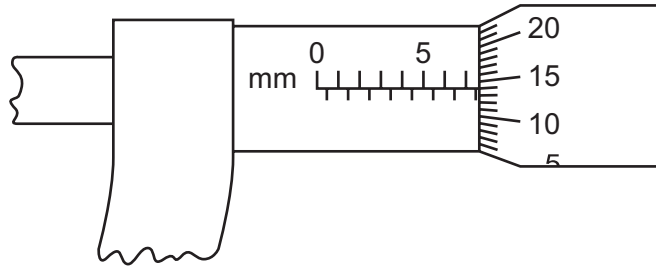

Which reading is shown?

- A 5.64 mm      B 7.14 mm      C 7.16 mm      D 7.64 mm

11 Which is a scalar quantity?

- A mass  
B force  
C velocity  
D weight

12 A workman measures, as **accurately** as possible, the length and internal diameter of a straight copper pipe.

The length is approximately 600 cm and the internal diameter is approximately 2 cm.

What is the best combination of instruments for the workman to use?

	internal diameter	length
A	ruler	ruler
B	ruler	tape
C	vernier calipers	ruler
D	vernier calipers	tape

Save My Exams! – The Home of Revision

For more awesome GCSE and A level resources, visit us at [www.savemyexams.co.uk/](http://www.savemyexams.co.uk/)

- 13 The diagram shows a stopwatch.

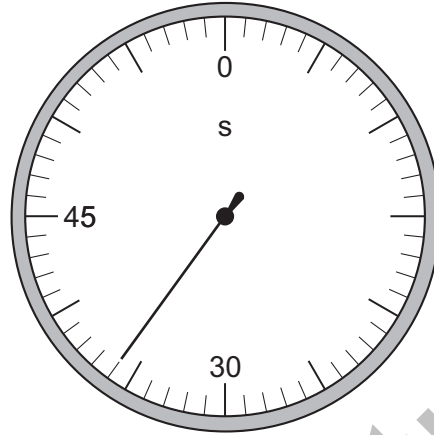

What is the reading on the stopwatch?

- A** 30.6 s      **B** 33.0 s      **C** 36.0 s      **D** 36.6 s
- 14 Each row contains a vector and a scalar.

In which row is the size of the vector equal to the size of the scalar?

	vector	
<b>A</b>	displacement of a car	speed of the car
<b>B</b>	velocity of a car	distance travelled by the car
<b>C</b>	velocity of a car	speed of the car
<b>D</b>	weight of a car	mass of the car

- 15 What is the size of the resultant of the two forces shown in the diagram?

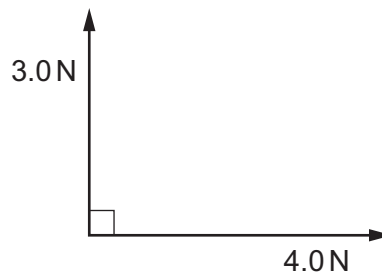

- A** 1.0 N      **B** 3.5 N      **C** 5.0 N      **D** 7.0 N

**Save My Exams! – The Home of Revision**

For more awesome GCSE and A level resources, visit us at [www.savemyexams.co.uk/](http://www.savemyexams.co.uk/)

- 16 Forces of 25 N and 40 N act on an object in the directions shown.

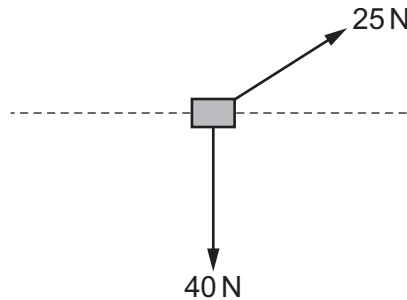

Which arrow shows the direction of the resultant force on the object?

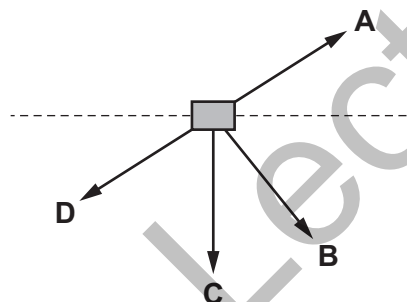

- 17 Which device can be used to measure the thickness of a single sheet of paper?
- A** a metre rule
  - B** a micrometer
  - C** a plastic ruler
  - D** a measuring tape

**Save My Exams! – The Home of Revision**

For more awesome GCSE and A level resources, visit us at [www.savemyexams.co.uk/](http://www.savemyexams.co.uk/)

18 In a test, four students linked the quantities on the left with their units on the right.

Which student matched them all correctly?

**A**

frequency	<del>————</del>	<del>m/s<sup>2</sup></del>
acceleration	<del>————</del>	<del>J</del>
latent heat	<del>————</del>	<del>Hz</del>
power	————	W

**B**

frequency	<del>————</del>	<del>m/s<sup>2</sup></del>
acceleration	————	J
latent heat	<del>————</del>	<del>Hz</del>
power	————	W

**C**

frequency	————	m/s <sup>2</sup>
acceleration	<del>————</del>	<del>J</del>
latent heat	<del>————</del>	<del>Hz</del>
power	<del>————</del>	<del>W</del>

**D**

frequency	<del>————</del>	<del>m/s<sup>2</sup></del>
acceleration	<del>————</del>	<del>J</del>
latent heat	<del>————</del>	<del>Hz</del>
power	<del>————</del>	<del>W</del>



Save My Exams! - The Home of Revision

For more awesome GCSE and A level resources, visit us at [www.savemyexams.co.uk/](http://www.savemyexams.co.uk/)

19 Forces of 3 N and 4 N act as shown in the diagram.

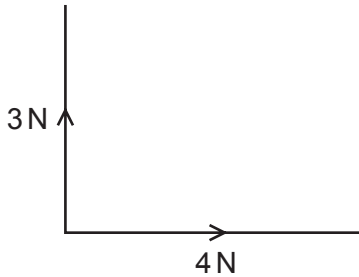

Which diagram shows the resultant  $R$  of these two forces?

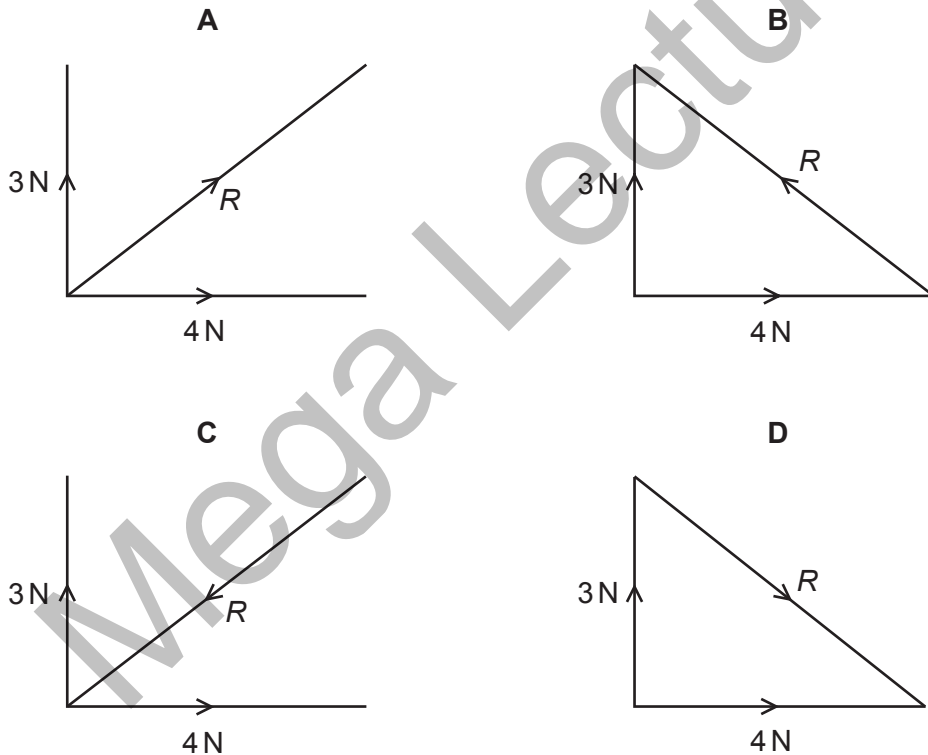

**Save My Exams! – The Home of Revision**

For more awesome GCSE and A level resources, visit us at [www.savemyexams.co.uk/](http://www.savemyexams.co.uk/)

- 20 A micrometer is used to measure the diameter of a uniform wire.

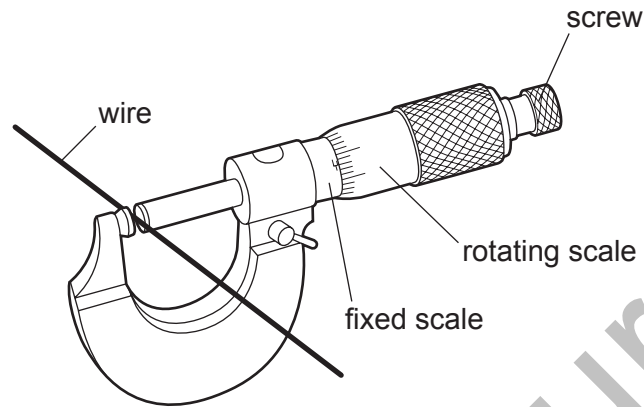

What is done to obtain an accurate answer?

- A Find the reading and add or subtract the zero error.
  - B Make the micrometer horizontal.
  - C Subtract the fixed scale reading from the rotating scale reading.
  - D Subtract the rotating scale reading from the fixed scale reading.
- 21 Before marking the finishing line on a running track, a groundsman measures out its 100m length.
- Which instrument is the most appropriate for this purpose?
- A measuring tape
  - B metre rule
  - C 30 cm ruler
  - D micrometer

**Save My Exams! – The Home of Revision**

For more awesome GCSE and A level resources, visit us at [www.savemyexams.co.uk/](http://www.savemyexams.co.uk/)

22 When there is no wind, the engines of an airship push it due north at  $20\text{ m/s}$ .

The wind is blowing from the west at  $12\text{ m/s}$ .

Which vector diagram correctly shows how the resultant velocity  $R$  of the airship is obtained?

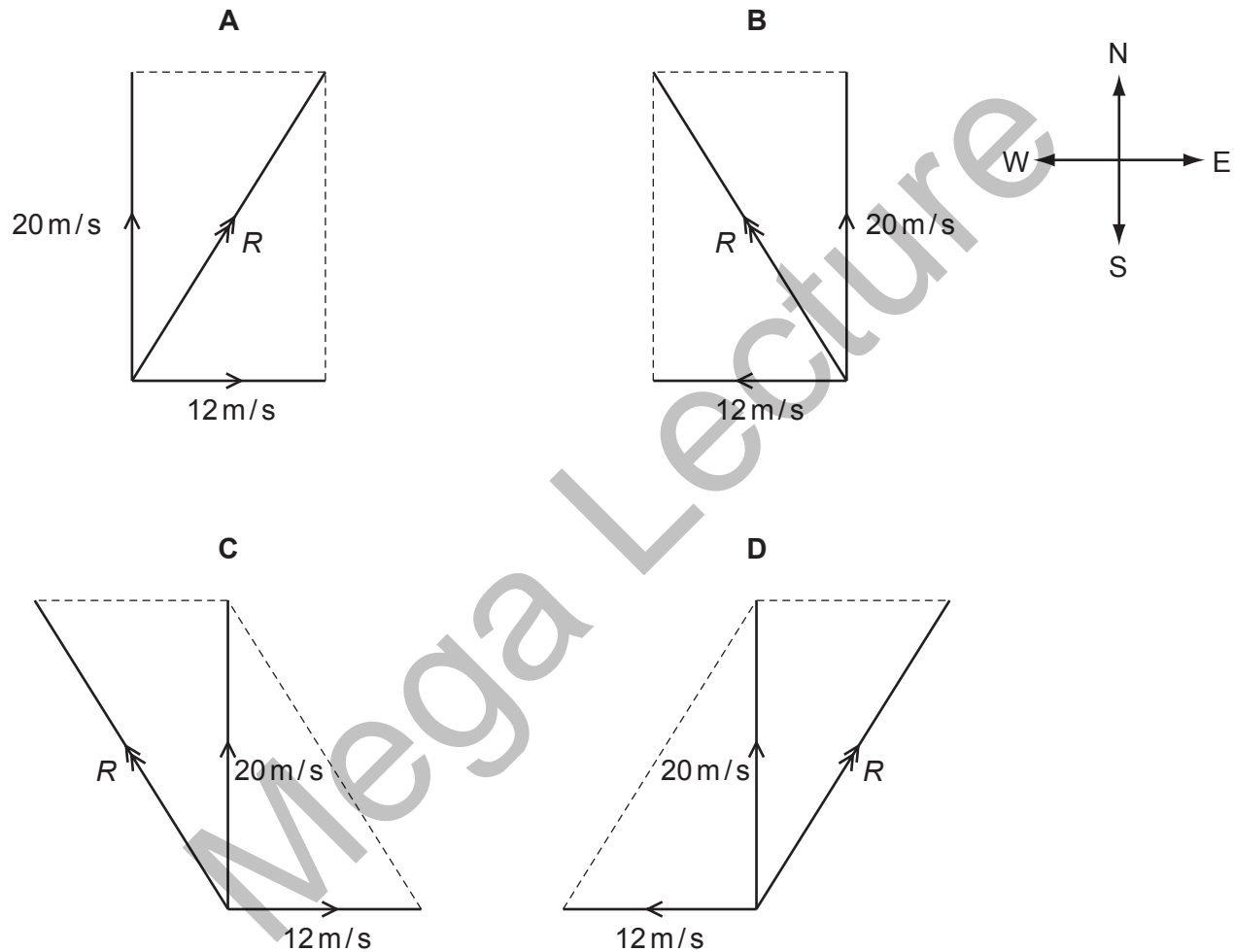

**Save My Exams! – The Home of Revision**

For more awesome GCSE and A level resources, visit us at [www.savemyexams.co.uk/](http://www.savemyexams.co.uk/)

23 A length of copper pipe, of uniform cross-section and several metres long, carries water to a tap.

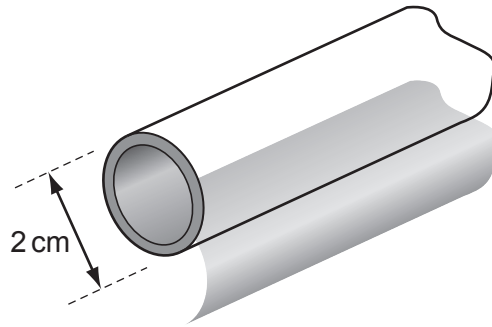

Measurements are taken to determine accurately the volume of copper in the pipe.

Which instruments are used?

- A calipers and micrometer
- B micrometer and rule
- C rule and tape
- D tape and calipers

24 A manufacturer measures accurately the dimensions of a wooden floor tile.

The approximate dimensions of the tile are shown.

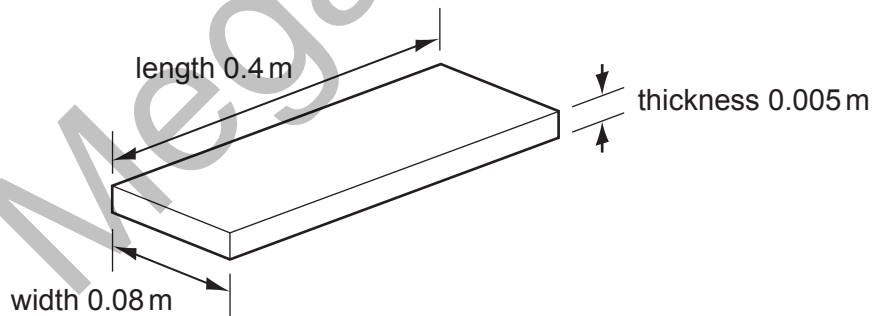

Which instruments are used to measure accurately each of these dimensions?

	length	thi	width
A	metre rule	micrometer	vernier calipers
B	metre rule	vernier calipers	micrometer
C	micrometer	metre rule	vernier calipers
D	vernier calipers	micrometer	metre rule

Save My Exams! – The Home of Revision

For more awesome GCSE and A level resources, visit us at [www.savemyexams.co.uk/](http://www.savemyexams.co.uk/)

25 Which pair of quantities includes one scalar and one vector?

- A mass                      time
- B temperature            time
- C temperature            velocity
- D velocity                  weight

26 A reel of copper wire is labelled 'length 30m' and 'diameter 2mm'. A student calculates the volume of the copper wire.

Which instruments does he use to measure accurately the length and the diameter of the wire?

	length	diameter
A	rule	calipers
B	rule	micrometer
C	tape	calipers
D	tape	micrometer

27 Which row correctly shows examples of a vector quantity and a scalar quantity?

	vector	scalar
A	area	force
B	mass	density
C	velocity	acceleration
D	weight	volume

28 Vernier calipers read to one tenth of a millimetre.

Which reading is given to this precision?

- A 3.3 cm                  B 3.31 cm                  C 3.310 cm                  D 3.312 cm

**Save My Exams! – The Home of Revision**

For more awesome GCSE and A level resources, visit us at [www.savemyexams.co.uk/](http://www.savemyexams.co.uk/)

29 Velocity is given by the change in displacement divided by the change in time.

How many vector quantities appear in this statement?

- A 0                      B 1                      C 2                      D 3

30 The level of water in a measuring cylinder is  $75 \text{ cm}^3$ . A stone of volume  $20 \text{ cm}^3$  is lowered into the water.

What is the new reading of the water level?

- A  $20 \text{ cm}^3$               B  $55 \text{ cm}^3$               C  $75 \text{ cm}^3$               D  $95 \text{ cm}^3$

31 A plumber measures, as **accurately** as possible, the length and internal diameter of a straight copper pipe.

The length is approximately 80 cm and the internal diameter is approximately 2 cm.

What is the best combination of instruments for the plumber to use?

	internal diameter	length
A	rule	rule
B	rule	tape
C	vernier calipers	rule
D	vernier calipers	tape

32 What is the correct unit for the quantity shown?

	quantity	unit
A	electromotive force (e.m.f.)	N
B	latent heat	J
C	pressure	$\text{kg/m}^3$
D	weight	kg

**Save My Exams! – The Home of Revision**

For more awesome GCSE and A level resources, visit us at [www.savemyexams.co.uk/](http://www.savemyexams.co.uk/)

- 33 The diameter and the length of a thin wire, approximately 1 m in length, are measured as accurately as possible.

What are the best instruments to use?

	diameter	length
<b>A</b>	micrometer	rule
<b>B</b>	micrometer	vernier calipers
<b>C</b>	rule	tape
<b>D</b>	vernier calipers	rule

- 34 A quantity is quoted as having a value of 6.2 ms.

In what units is it measured?

- A** metres
- B** metres per second
- C** microseconds
- D** milliseconds

- 35 The following statements are about motion.

- 1 A plane flies due East for 600 km.
- 2 A runner's average speed in a race around a track is 5 m/s.
- 3 A snail crawls at 3 mm/s in a straight line towards a lettuce.
- 4 A tourist travels 500 km on a journey.

Which statements describe vector quantities?

- A** 1 and 2      **B** 1 and 3      **C** 2 and 3      **D** 2 and 4

- 36 Power is measured in watts.

What is the correct symbol for millions of watts?

- A** mw      **B** mW      **C** Mw      **D** MW

Save My Exams! – The Home of Revision

For more awesome GCSE and A level resources, visit us at [www.savemyexams.co.uk/](http://www.savemyexams.co.uk/)

37 Which list contains only scalar quantities?

- A acceleration, displacement, velocity
- B distance, force, speed
- C force, length, time
- D length, mass, speed

38 Vernier calipers are shown with the jaws closed.

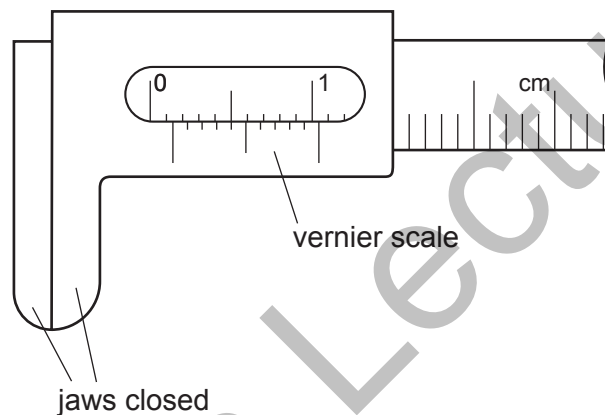

What is the zero error?

- A 0.04 cm
- B 0.05 cm
- C 0.14 cm
- D 0.15 cm

39 Which instrument is most easily used to measure the internal diameter of a pipe?

- A manometer
- B measuring cylinder
- C micrometer
- D vernier calipers



**Save My Exams! – The Home of Revision**

For more awesome GCSE and A level resources, visit us at [www.savemyexams.co.uk/](http://www.savemyexams.co.uk/)

40 Which statement about scalars and vectors is correct?

- A A scalar has direction but no size.
- B A scalar has size but no direction.
- C A vector has direction but no size.
- D A vector has size but no direction.

41 Vernier calipers read to one tenth of a millimetre.

Which reading shows this precision?

- A 3.3 cm      B 3.31 cm      C 3.310 cm      D 3.312 cm

42 Which list contains only scalar quantities?

- A acceleration, displacement, mass
- B acceleration, distance, speed
- C displacement, mass, velocity
- D distance, mass, speed

43 What is the reading on this micrometer?

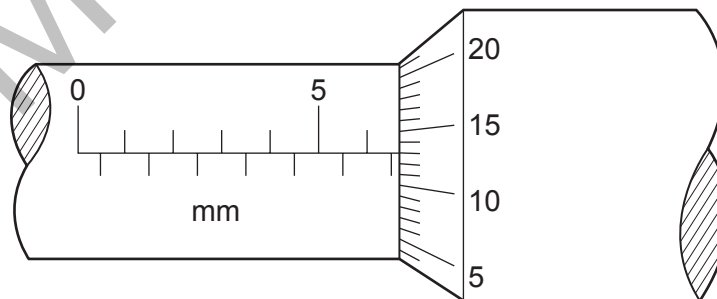

- A 5.43 mm      B 6.63 mm      C 7.30 mm      D 8.13 mm

**Save My Exams! – The Home of Revision**

For more awesome GCSE and A level resources, visit us at [www.savemyexams.co.uk/](http://www.savemyexams.co.uk/)

- 44 A manufacturer needs to measure accurately the dimensions of a wooden floor tile.

The approximate dimensions of the tile are shown.

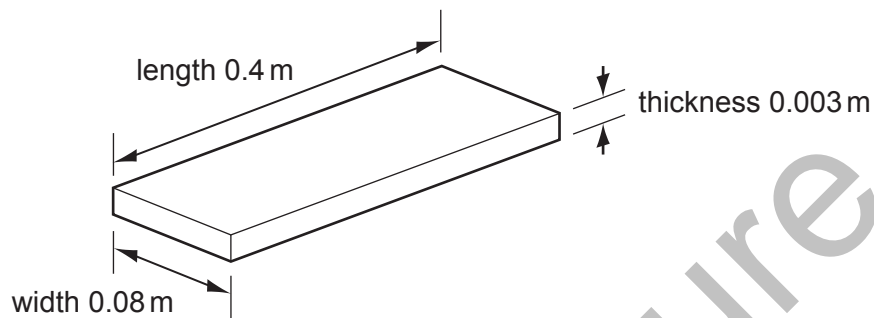

Which instruments measure each of these dimensions accurately?

	length	thi	width
<b>A</b>	metre rule	micrometer	vernier calipers
<b>B</b>	metre rule	vernier calipers	micrometer
<b>C</b>	micrometer	metre rule	vernier calipers
<b>D</b>	vernier calipers	micrometer	metre rule

**Save My Exams! – The Home of Revision**

For more awesome GCSE and A level resources, visit us at [www.savemyexams.co.uk/](http://www.savemyexams.co.uk/)

- 45 The width of a wooden block is measured using vernier calipers.

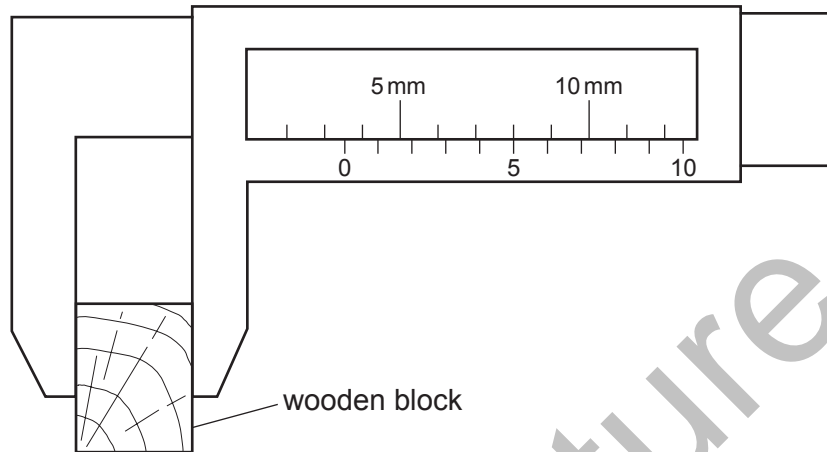

What is the width of the block?

- A** 3.5 mm      **B** 5.3 mm      **C** 8.0 mm      **D** 8.5 mm
- 46 Which of the following correctly lists one scalar and one vector quantity?

	scalar quantity	vector quantity
<b>A</b>	displacement	work
<b>B</b>	energy	force
<b>C</b>	force	acceleration
<b>D</b>	velocity	mass

**Save My Exams! – The Home of Revision**

For more awesome GCSE and A level resources, visit us at [www.savemyexams.co.uk/](http://www.savemyexams.co.uk/)

47 In an experiment, a ball is rolled down a curved track that is about half a metre long.

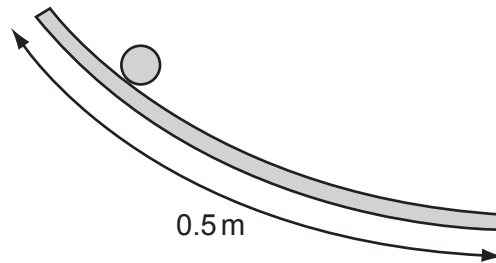

Which measuring device should be used to measure the length accurately?

- A** metre rule
- B** micrometer
- C** tape measure
- D** vernier calipers

48 The diagram shows a vernier scale.

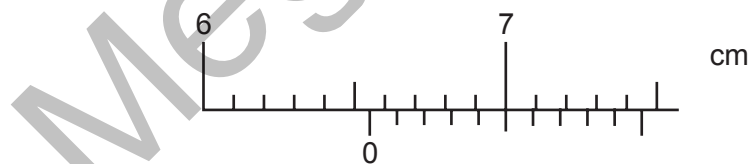

What is the reading on the vernier scale?

- A** 6.50 cm
- B** 6.55 cm
- C** 7.00 cm
- D** 7.05 cm

**Save My Exams! – The Home of Revision**

For more awesome GCSE and A level resources, visit us at [www.savemyexams.co.uk/](http://www.savemyexams.co.uk/)

- 49 The diagram shows one method of measuring the diameter of a beaker.

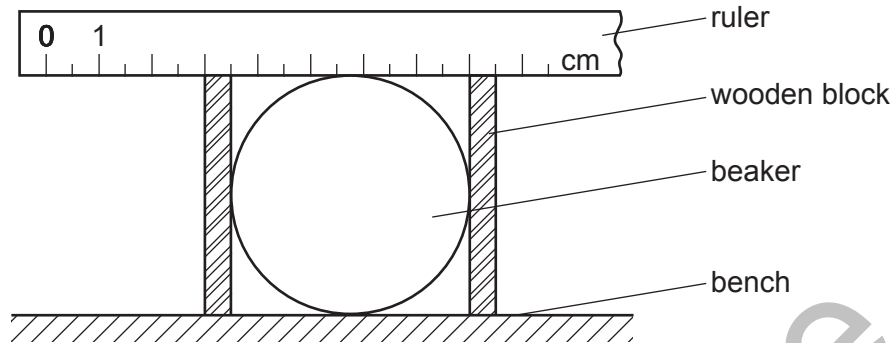

What is the diameter of the beaker?

- A** 4.5 cm      **B** 5.0 cm      **C** 5.5 cm      **D** 8.0 cm

- 50 A student studies some equations.

$$\text{power} = \text{work} / \text{time}$$

$$\text{force} = \text{mass} \times \text{acceleration}$$

$$\text{velocity} = \text{displacement} / \text{time}$$

How many vector quantities are contained in the equations?

- A** 1      **B** 2      **C** 3      **D** 4

- 51 Which instrument is used to measure the internal diameter of a pipe with a single measurement?

- A** manometer  
**B** measuring cylinder  
**C** micrometer  
**D** vernier calipers

- 52 Which is the correct statement about force and velocity?

- A** Force and velocity are both scalars.  
**B** Force and velocity are both vectors.  
**C** Force is a scalar, velocity is a vector.  
**D** Force is a vector, velocity is a scalar.

Save My Exams! – The Home of Revision

For more awesome GCSE and A level resources, visit us at [www.savemyexams.co.uk/](http://www.savemyexams.co.uk/)

- 53 The diagram shows a vernier V placed against a scale S.

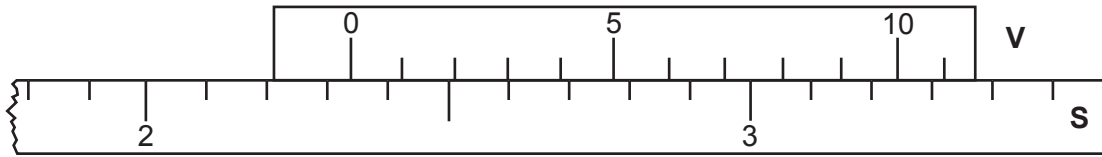

What is the vernier reading?

- A** 2.23                      **B** 2.26                      **C** 2.33                      **D** 2.36
- 54 A student has been asked to determine, as accurately as possible, the volume of a piece of wire. The wire is about 80 cm long and about 0.2 cm in diameter.

Which measuring instruments should the student use?

	length	diameter
<b>A</b>	metre rule	micrometer
<b>B</b>	metre rule	vernier callipers
<b>C</b>	micrometer	vernier callipers
<b>D</b>	vernier callipers	micrometer

**Save My Exams! – The Home of Revision**

For more awesome GCSE and A level resources, visit us at [www.savemyexams.co.uk/](http://www.savemyexams.co.uk/)

55 The diagram shows part of a vernier scale.

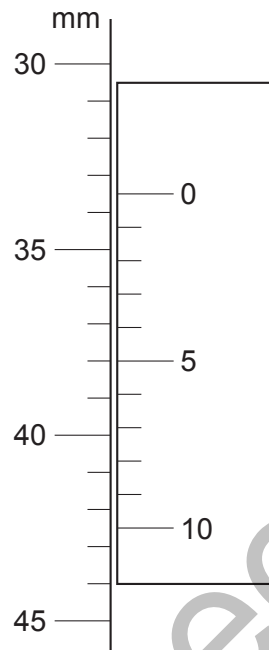

What is the correct reading?

- A** 30.5 mm      **B** 33.5 mm      **C** 38.0 mm      **D** 42.5 mm

56 The diagram shows part of a vernier scale.

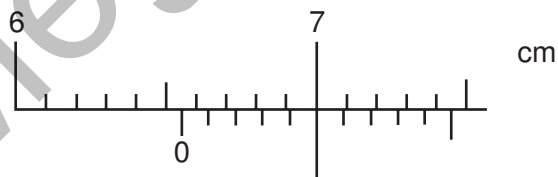

What is the reading on the vernier scale?

- A** 6.50 cm  
**B** 6.55 cm  
**C** 7.00 cm  
**D** 7.45 cm

**Save My Exams! – The Home of Revision**

For more awesome GCSE and A level resources, visit us at [www.savemyexams.co.uk/](http://www.savemyexams.co.uk/)

57 Which of the following groups of physical quantities consists only of scalars?

- A acceleration, force, velocity
- B acceleration, mass, speed
- C force, time, velocity
- D mass, speed, time

58 One oscillation of a swinging pendulum occurs when the bob moves from **X** to **Y** and back to **X** again.

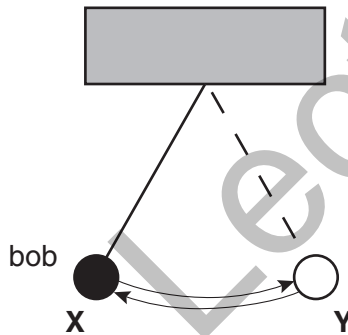

Using a stopwatch, which would be the most accurate way to measure the time for one oscillation of the pendulum?

- A Time 20 oscillations and multiply by 20.
- B Time 20 oscillations and divide by 20.
- C Time one oscillation.
- D Time the motion from **X** to **Y**, and double it.