

O Level Physics Syllabus Content for CAIE 2018-19 Exams

**CHAPTER 1:
PHYSICAL QUANTITIES, UNITS AND MEASUREMENT**

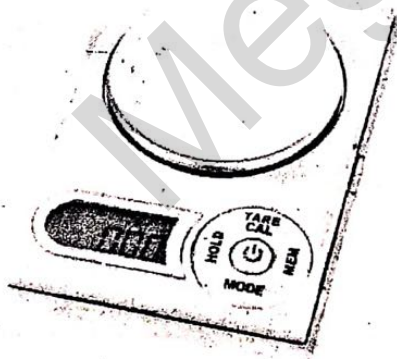
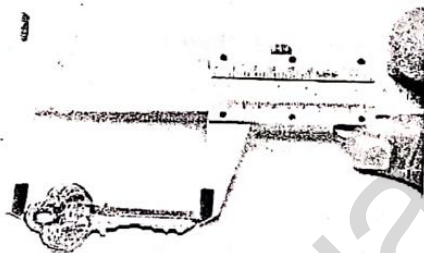
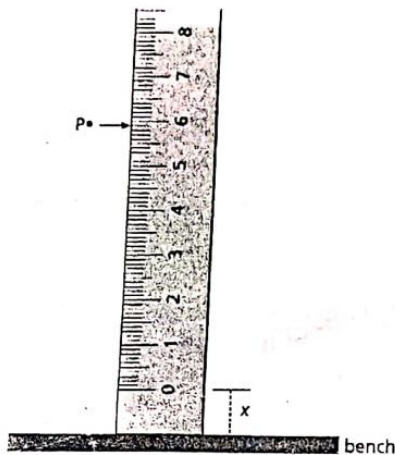

Syllabus Content

- 1.1 Scalars and vectors
- 1.2 Measurement techniques
- 1.3 Units and symbols

Learning outcomes

Candidates should be able to:

- a) Define the terms *scalar* and *vector*.
- b) Determine the resultant of two vectors by a graphical method.
- c) List the vectors and scalars from distance, displacement, length, speed, velocity, time, acceleration, mass and force.
- d) Describe how to measure a variety of lengths with appropriate accuracy using tapes, rules, micrometers and calipers. (The use of a vernier scale is **not** required.)
- e) Describe how to measure a variety of time intervals using clocks and stopwatches.
- f) Recognise and use the conventions and symbols contained in 'Signs, Symbols and Systematics',

ABDUL HAKEEM

0300-4810136

O / AS & A Level Physics

Physical Quantities, Units and Measurement

Basic Units:

In Physics, all physical quantities are usually measured in the "International System of Units", known as the SI units.

The "basic" quantities used in physics are:

1. Length: measures in meters (m).
2. Mass : measured in kilograms (kg).
3. Time : measured in seconds (s).

Some prefixes are used with the units to indicate a fraction of the unit or a multiple of the unit. Here are some important prefixes used in this course,

Prefixes	Notation	Prefixes	Notation
deci	(d) = 10^{-1}	kilo	(k) = 10^3
centi	(c) = 10^{-2}	micro	(μ) = 10^{-6}
mili	(m) = 10^{-3}	mega	(M) = 10^6

Measurements

For accuracy, a measurement is usually repeated several times, then the average value is obtained,

1. Measuring Lengths

A short distance or length is measured by a ruler, a longer distance is measured by a meter rule, very long distance (e.g. length of a hall or a game field) are measured by using a long measuring tape or trundle wheel.

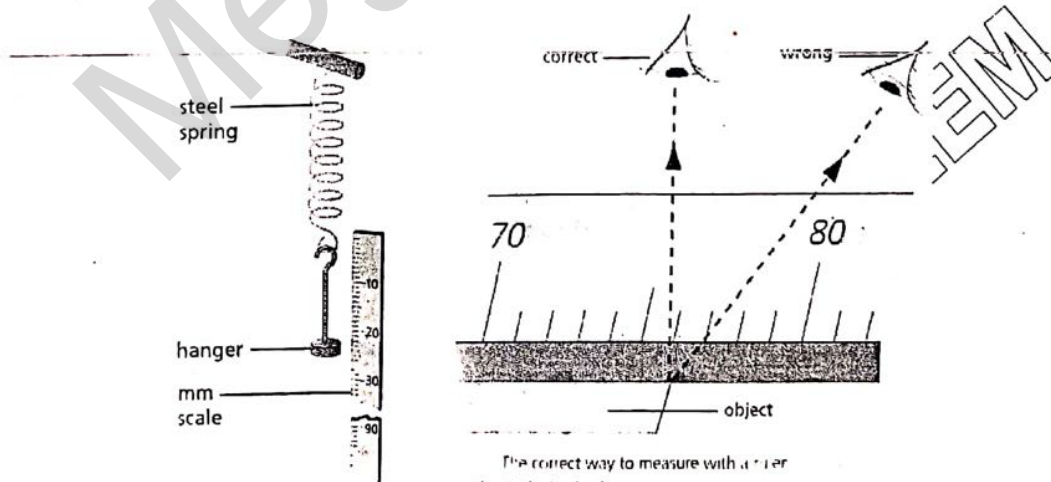

GREEN HAVEL ACCADEMY
 Grade 3-9/O-11/O/A Level/PATINETI/MDCAT/ECAT
 03125314148 | 031163333666 | 03116333444
 greenhall.edu.pk | greenhallacademy@gmail.com
 JOHAR TOWN | WAPDA TOWN | PARAGAN CITY
 03207777456
 DHA Phase-I | DHA Phase-IV | Faisal Town
 03315314143 | 03206868989 | 03116333777
 greenhall.edu.pk | greenhallacademy@gmail.com
 greenhalleducation

Steps:

1. Place the object very close to meter rule, (If you cannot do this, you may use a pointer).
2. Owing to the thickness of the ruler, the eye must be placed vertically above the mark being read to avoid the error due to parallax.
3. Take two readings at both ends of the object and subtract to the two readings to get the length.
4. Repeat the above steps several times and get the average value of the length.

Notes:

- a. If a certain reading is found to be wrong, exclude it; or repeat the same measurement once again.
- b. Many instruments which have a pointer moving above a scale are liable to parallax errors if the eye is not placed vertically above the pointer. Good instruments have a plane mirror under the scale. Parallax error is avoided if the eye is positioned so that the pointer exactly covers its own image in the mirror.
- c. Parallax is the apparent relative motion of two objects owing to the movement of the observer.

Remarks:

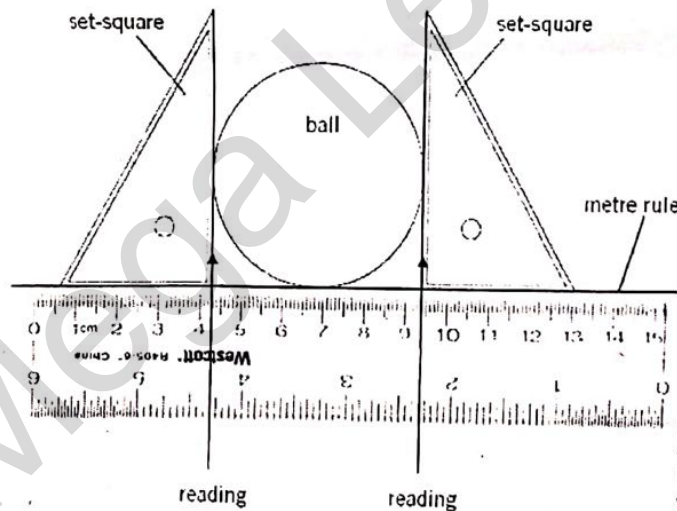

1. When using a tape measure, avoid bends in the tape and keep it in a perpendicular direction to the two walls.
2. To measure the diameter of a sphere or a cylinder, place it between two vertical parallel blocks and take the difference between the two readings at its two ends.
3. If the system is not stable so you cannot place a ruler on it, one can use the dividers such that if two pins are exactly at the two ends of the distance to be measured, then place the dividers on a rule to find the required length.

GREEN HALL ACADEMY
Grade 3-9/O-11/O/A Level/ SAT/ IGCSE/ MDC/ ATE/ CAT
GULBERG | JOHAR TOWN | WAPDA TOWN | PARAGON CITY | DHA Phase-I | DHA Phase-IV | Faisal Town
03125314148 | 03116333666 | 03116333444 | 03207777456 | 03315314143 | 03206666989 | 03116333777
greenhall.edu.pk | greenhallacademy@gmail.com | greenhalleducation | greenhallacademy@gmail.com | greenhalleducation

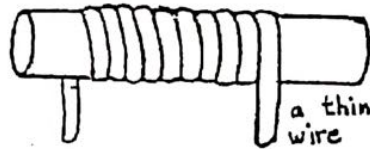
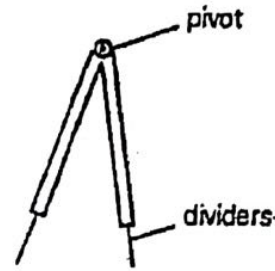
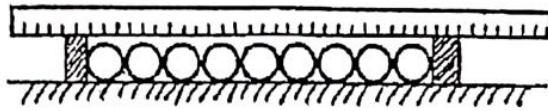

4. To measure the diameter of a wire, a bead, or a small ball bearing, one should arrange a row of a large number of them and measured the total length. Now, divide this length by the number of beads (to turns) to get the desired diameter.
5. Think how to get the thickness of a paper of your textbook.

2. Measuring Volumes:

(a) Volumes of Liquids:

The volume of a liquid is usually measured by a measuring cylinder. When measuring the volume by a cylinder, one should notice these precautions:

1. The Cylinder must be placed on a horizontal bench, otherwise error may arise due to titling.
2. Take the reading at the bottom of the meniscus or curved surface of the liquid. (mercury is an exceptional case, one reads at the top of the mercury's meniscus).
3. The line of eye sight should be perpendicular to the scale to avoid the error due to parallax.

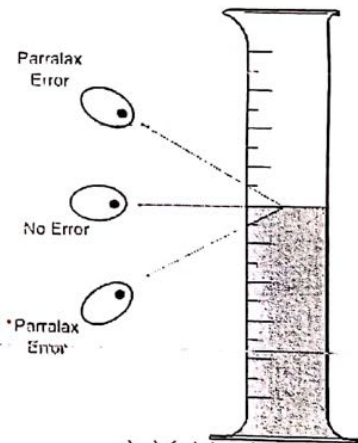

(* Small volume of liquids can be measured accurately by using a pipette or a burette.

(b) Volume of Regular solids:

The volume of a regular solid can be calculated by measuring dimensions and using the suitable formula.

For a rectangular block:

$$\text{Volume} = \text{length} \times \text{width} \times \text{height}$$

For a sphere of radius "r":

$$\text{Volume} = \frac{4}{3}\pi r^3$$

For cylinder of radius "r" & height "h"

$$\text{Volume} = 2\pi r h$$

(c) Volume of Irregular solids:

The volume of solids of an irregular shape can be determined by immersing it in a liquid as follows:

1. Measure the volume (v_1) of a certain amount of a liquid by a measuring cylinder.
2. Tie the solids body by a fine thread and immerse it gently in the liquid, then get another reading for the volume (v_2) of the liquid plus the solids body.
3. The volume of the solids body equals ($v_2 - v_1$)

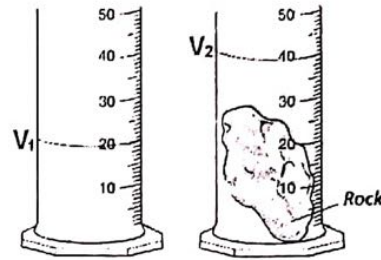

Remarks:

- i. When measuring the volume of small particles containing air spaces (e.g. some particles), the measured volume is greater than the true volume of the particles only.
- ii. Sometimes the displacement can, together with a measuring cylinder, can be used to measure the volume of an irregular solid, as shown in the figure.

3. Measuring Masses:

The Mass of a body is the measure of amount of substance contained in that body. The mass depends on the number and the type of the atoms contained in the body. The mass is usually measured in kilograms (or grams) by using a balance. The mass of an object is always constant; it does not change by change in place, temperature, time, etc.....



Top Pan Balance

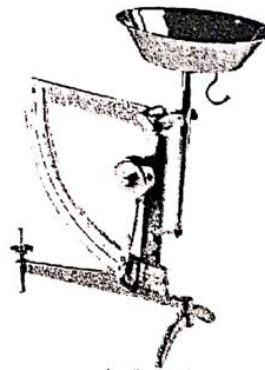

Lever Balance

Mass can be measured by using a top-pan balance or a lever balance. When using a balance, notice that:

- a. The balance is clean & dry,
- b. The balance is placed horizontally,
- c. The balance pointer or digits read zero (otherwise notice and record the zero error).

Table of Results:

Length of Pendulum L/ cm	Time of 30 Swings t/s	Time of one swing, T/S (T =t/30)

All measurement should be carefully recorded in a "Table of Results". It should contain headings for all quantities measured together with the units used.

1. The table of results of the simple pendulum experiment which has been given before is a good example.
2. When measuring the time taken by a free falling body, one can use an electronic timer to get an accurate value of this very small time. If the experiment is done by a stop-watch, one has to repeat each measurement and calculate the average time of fall.

Distance d/cm	Time of fall t/s			Ave time of fall t/s
	t ₁	t ₂	t ₃	

Graphs:

The graph should have:

- a) A title
- b) Both axes labeled
- c) Units on each axis.
- d) Scales used on each axis.
- e) Points plotted with crosses (x) or with dot (.)



The graph should cover all graph paper.

A straight line (or smooth curve) which passes through most of the points (or leaves equal no. of points on either side of graph).

Gradient or Slope:

The gradient (or slope) of a line is the tangent of the angle θ which the line makes with the horizontal.

$$\text{Gradient} = \tan \theta = \frac{AB}{BC}$$

$$= \frac{\text{Vertical}}{\text{Horizontal}}$$

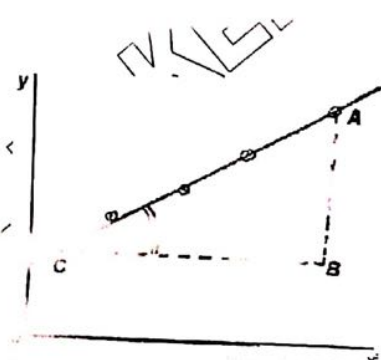

- Write the units used for AB & BC to get the unit of the gradient.
- If the line slopes downwards to the right, the gradient is negative

How to choose a convenient scale for an axis:

- suppose that the minimum number in the data is A and the maximum number is B,
- Count the number of scale divisions available for representing between A and B. Let this number be N.
- Calculate $(B-A) / N$. Find a number composed of either 1 or 2 or 5 that is just greater than $B-A/N$. This number will be the scale division.

Example:

Assume the largest number in the data is 12.3 and the smallest number is 5.8. Assume there are 17 divisions available for these data. $(12.3 - 5.8) / 17 = 0.38$. Then each scale division will be 0.5. The starting number in the axis is 5.5 and the last number is 12.5.

Proportionality:

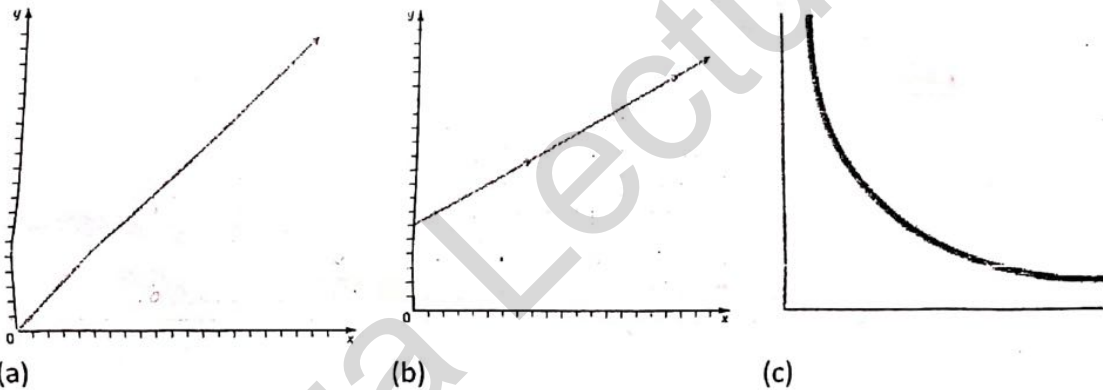

- The relation between two variables is directly proportional when relation is straight line through the origin Fig. (a). ($y = k.x$).
- The relation is linear but not directly proportional when relation is a straight line but not through the origin Fig. (b). ($y = k.x + c$).
- The inversely proportional relation gives a curve Fig. (c). ($y.x = k$).

Vectors and Scalars:

A vector quantity is that which has both magnitude and direction.

Examples: Displacement, Force, weight, velocity, acceleration, momentum...

A vector is usually represented by an arrow whose length is proportional to the size of the vector and it points in the direction of the vector. A good representation of the vector needs to choose a suitable scale for drawing the vector.

A Scalars quantity is that which has magnitude only.

It has NO direction.

Examples: mass, length, volume, temperature, time, energy...

Forces and resultants

Force has both magnitude (size) and direction. It is represented in diagrams by a straight line with an arrow to show its direction of action. Usually more than one force acts on an object. As a simple example, an object resting on a table is pulled downwards by its weight W and pushed upwards by a force R due to the table supporting it (see Figure below). Since the object is at rest, the forces must balance, i.e. $R = W$.

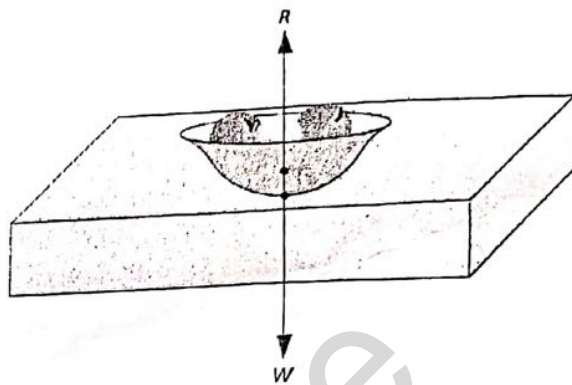

In structures such as a giant oil platform, two or more forces may act at the same point. It is then often useful for the design engineer to know the value of the single force, i.e. the **resultant**, which has exactly the same effect as these forces. If the forces act in the same straight line, the resultant is found by simple addition or subtraction as shown in Figure; if they do not they are added by using the parallelogram law.

Parallelogram law

Arrange the apparatus as in Figure with a sheet of paper behind it on a vertical board. We have to find the resultant of forces P and Q . Read the values of P and Q from the spring balances. Mark on the paper the directions of P , Q and W as shown by the strings. Remove the paper and, using a scale of 1 cm to represent 1 N, draw OA , OB and OD to represent the three forces P , Q and W which act at O , as in Figure 7.4b. ($W =$ weight of the 1 kg mass = 9.8 N; therefore $OD = 9.8$ cm.)

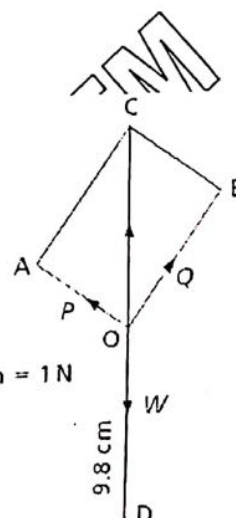
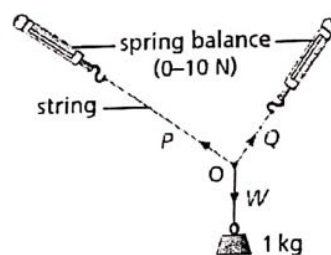

Use the scale 1 cm = 1 N

Finding a resultant by the parallelogram law

P and Q together are balanced by W and so their resultant must be a force equal and opposite to W . Complete the parallelogram $OACB$. Measure the diagonal OC ; if it is equal in size (i.e. 9.8 cm) and opposite in direction to W then it represents the resultant of P and Q . The parallelogram law for adding two forces is: If two forces acting at a point are represented in size and direction by the sides of a parallelogram drawn from the point, their resultant is represented in size and direction by the diagonal of the parallelogram drawn from the point.

Worked example

Find the resultant of two forces of 4.0 N and 5.0 N acting at an angle of 45° to each other. Using a scale of 1.0 cm = 1.0 N, draw parallelogram ABDC with AB = 5.0 cm, AC = 4.0 N and angle CAB = 45°. By the parallelogram law, the diagonal AD represents the resultant in magnitude and direction; it measures 8.3 cm, and angle BAD = 20°. ∴ Resultant is a force of 8.3 N acting at an angle of 20° to the force of 5.0 N.

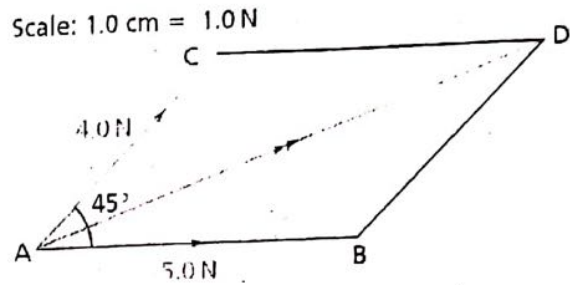

Examples of addition of forces

- Two people carrying a heavy bucket. The weight of the bucket is balanced by the force F , the resultant of F_1 and F_2 .
- Two tugs pulling a ship. The resultant of T_1 and T_2 is forwards in direction, and so the ship moves forwards (as long as the resultant is greater than the resistance to motion of the sea and the wind).

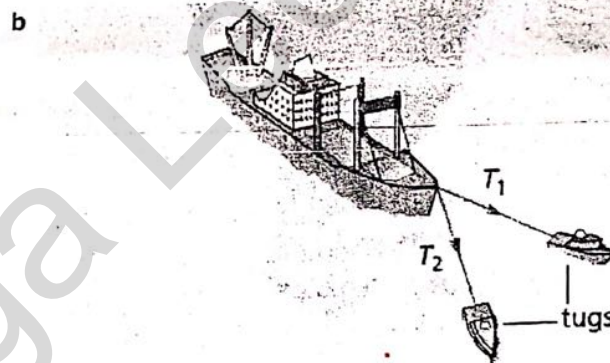
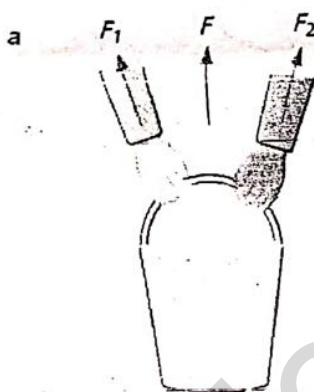

Vectors and scalars

A **vector** quantity is one such as force which is described completely only if both its size (magnitude) and direction are stated. It is not enough to say, for example, a force of 10 N, but rather a force of 10 N acting vertically downwards. A vector can be represented by a straight line whose length represents the magnitude of the quantity and whose direction gives its line of action. An arrow on the line shows which way along the line it acts.

A **scalar** quantity has magnitude only. Mass is a scalar and is completely described when its value is known. Scalars are added by ordinary arithmetic; vectors are added geometrically, taking account of their directions as well as their magnitudes.