

www.fahadsacademy.com

ELECTROLYSIS : THEORY+MCQS

Contents

MULTIPLE CHOICE QUESTIONS	2
THEORY QUESTIONS	37

MULTIPLE CHOICE QUESTIONS

18 In which circuit does the bulb light?

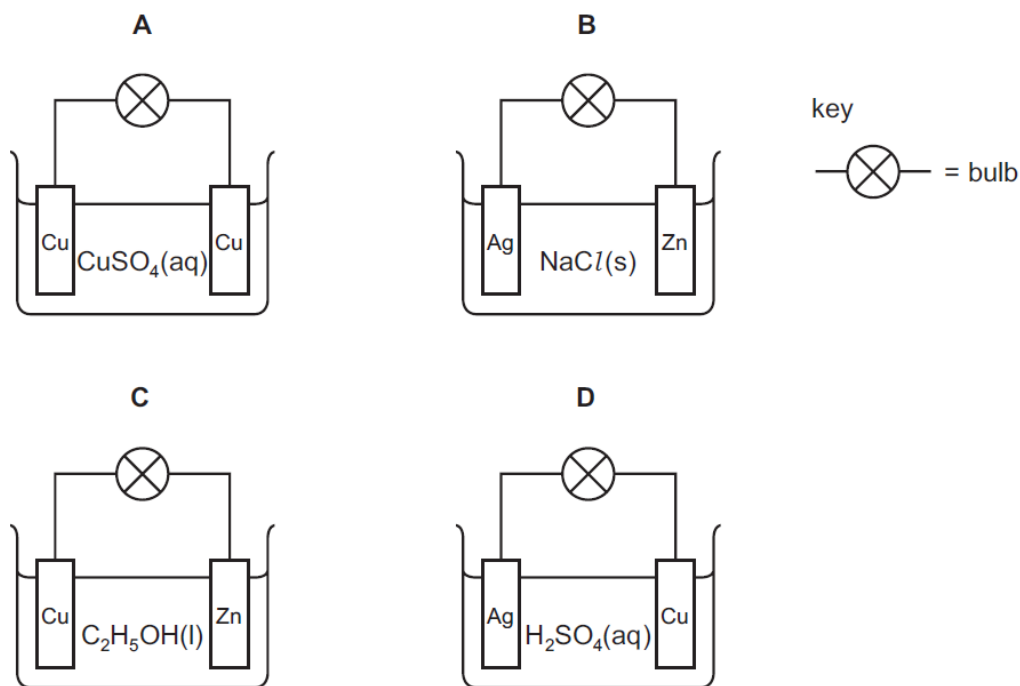

5070_s14_qp12

13 A concentrated aqueous solution of sodium chloride is electrolysed.

What are the equations for the reactions taking place at the cathode (negative electrode) and the anode (positive electrode)?

	cathode (-ve)	anode (+ve)
A	$2\text{H}^+ + 2\text{e}^- \rightarrow \text{H}_2$	$2\text{Cl}^- \rightarrow \text{Cl}_2 + 2\text{e}^-$
B	$2\text{H}^+ + 2\text{e}^- \rightarrow \text{H}_2$	$4\text{OH}^- \rightarrow \text{O}_2 + 2\text{H}_2\text{O} + 4\text{e}^-$
C	$\text{Na}^+ + \text{e}^- \rightarrow \text{Na}$	$2\text{Cl}^- \rightarrow \text{Cl}_2 + 2\text{e}^-$
D	$\text{Na}^+ + \text{e}^- \rightarrow \text{Na}$	$4\text{OH}^- \rightarrow \text{O}_2 + 2\text{H}_2\text{O} + 4\text{e}^-$

5070_s14_qp12

14 What is observed during the electrolysis of aqueous copper(II) sulfate using carbon electrodes?

- A A pink solid is deposited on the anode.
- B Bubbles form on the negative electrode.
- C The colour of the solution fades.
- D The negative electrode becomes smaller.

5070_s14_qp12

8 Which substance can conduct electricity by the movement of ions?

- A copper
- B graphite
- C mercury
- D sodium chloride

5070_s14_qp12

- 21 Aqueous copper(II) sulfate is electrolysed using copper electrodes. The current is constant and the anode (positive electrode) is weighed at regular intervals.

Which graph is obtained when the mass of the anode is plotted against time?

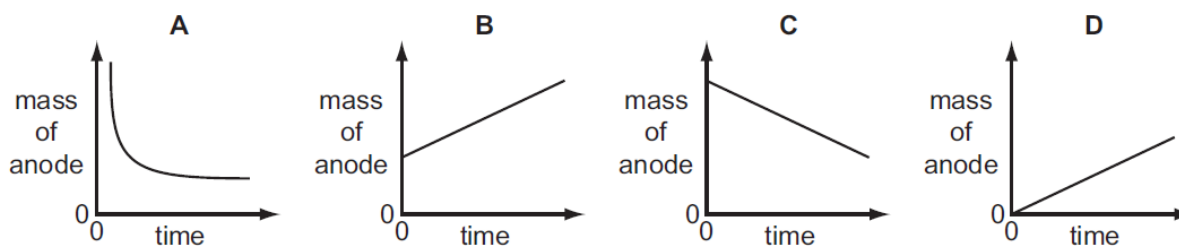

- 22 In the extraction of aluminium by electrolysis, its oxide is dissolved in molten cryolite. Cryolite is a sodium salt.

Aluminium is deposited at the1..... and it can be deduced that aluminium is2..... sodium in the reactivity series.

Which words correctly complete gaps 1 and 2?

	1	2
A	+ve electrode	above
B	+ve electrode	below
C	-ve electrode	above
D	-ve electrode	below

5070_s14_qp11

16 In which circuit does the bulb light?

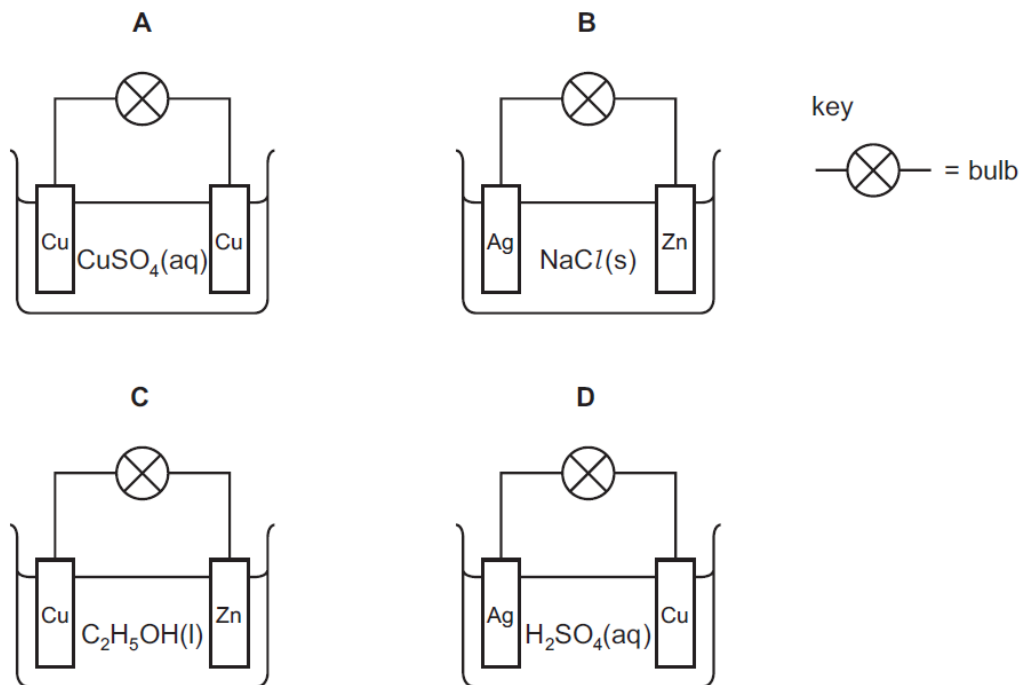

5070_s14_qp11

7 Graphite is often used as the electrodes in the electrolysis of solutions.

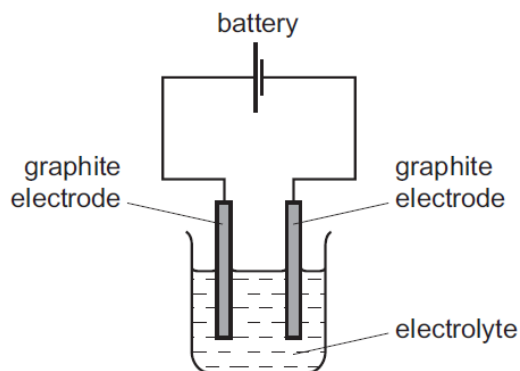

Which particles are involved in the conduction of electricity by graphite?

- A electrons only
- B negative ions only
- C positive ions and electrons
- D positive ions and negative ions

5070_s14_qp11

- 16 It has been suggested that the cars of the future could be powered by fuel cells. One type of fuel cell uses the chemical reaction between oxygen and hydrogen to produce electricity.

What would be a disadvantage of using this type of fuel cell to power a car?

- A A car cannot be powered by electricity.
- B The hydrogen tank might split in an accident, leading to an explosion.
- C The product of the reaction between oxygen and hydrogen is toxic.
- D The oxygen would need to be obtained from air.

5070_w13_qp12

- 14 Which arrangement would be used to electroplate copper onto a steel key?

	electrolyte	anode (positive electrode)	cathode (negative electrode)
A	aqueous copper(II) sulfate	piece of pure copper	steel key
B	aqueous copper(II) sulfate	steel key	piece of pure copper
C	aqueous sulfuric acid	piece of pure copper	steel key
D	aqueous sulfuric acid	steel key	piece of pure copper

5070_w13_qp12

- 12 Which process will separate an ionic compound PQ into its elements P and Q ?

- A distillation
- B electrolysis
- C filtration
- D precipitation

5070_w13_qp12

14 When dilute sulfuric acid is electrolysed between inert electrodes, which statements are correct?

- 1 Hydrogen is released at the negative electrode.
- 2 Oxygen is released at the positive electrode.
- 3 Sulfur dioxide is released at the positive electrode.
- 4 The acid becomes more concentrated.

A 1, 2 and 4 B 1 and 2 only C 2 and 3 D 3 and 4

5070_w13_qp11

15 When electrolysed using inert electrodes, which dilute solution would produce the greatest increase in mass of the cathode?

[A_r : Al, 27; Cu, 64; Pb, 207; Ag, 108]

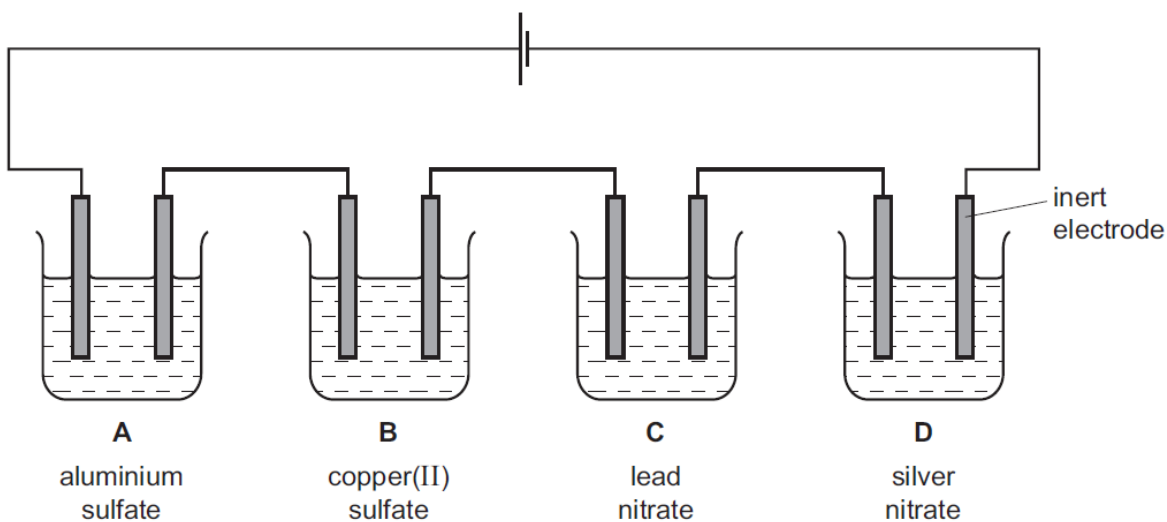

5070_w13_qp11

- 8 The diagram shows the electrolysis of aqueous sodium chloride and of molten sodium chloride.

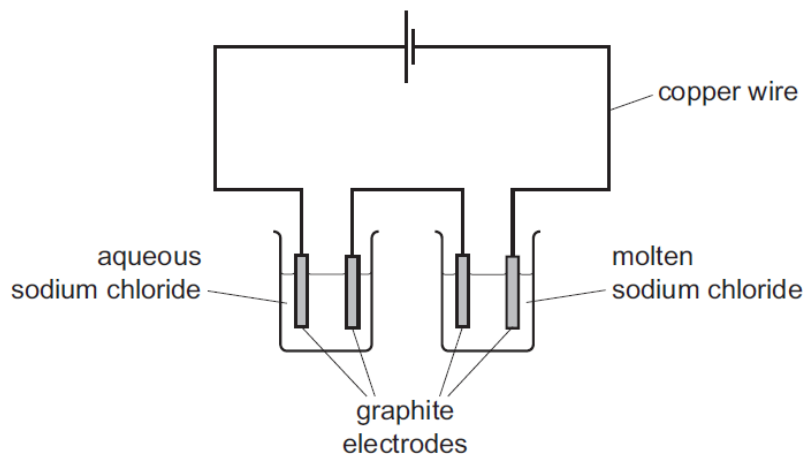

Which substance in the diagram has both positive ions and mobile electrons?

- A aqueous sodium chloride
- B copper wire
- C graphite electrodes
- D molten sodium chloride

5070_w13_qp11

- 6 Which substance will **not** conduct electricity at room temperature and pressure?

- A dilute nitric acid
- B graphite
- C mercury
- D sodium chloride

5070_w13_qp11

- 12 In the experiment shown in the diagram, the bulb lights and two colourless gases are formed, one at each electrode.

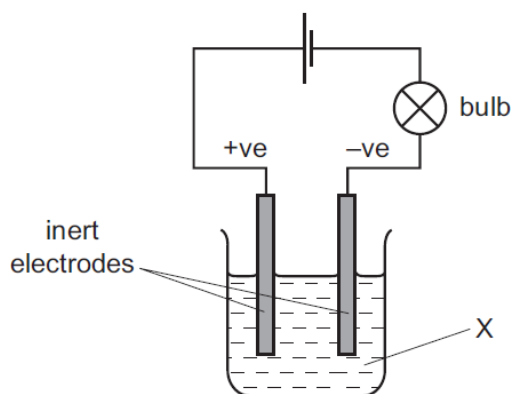

What is X?

- A concentrated aqueous sodium chloride
- B dilute sulfuric acid
- C methanol
- D molten sodium chloride

5070_w12_qp12

- 6 When concentrated aqueous sodium chloride is electrolysed using carbon electrodes, which row correctly states the products at the electrodes and the solution remaining?

	cathode (-)	anode (+)	solution remaining
A	chlorine	hydrogen	hydrochloric acid
B	hydrogen	chlorine	sodium hydroxide
C	hydrogen	oxygen	sodium chloride
D	sodium	chlorine	water

5070_w12_qp12

- 18 What is a property of the hydroxide, OH^- , ion?

- A It combines with hydrogen to form water.
- B It is present in water.
- C It readily breaks down into hydrogen ions and oxide ions.
- D It travels to the cathode in electrolysis of an aqueous solution.

5070_w12_qp11

13 In the experiment shown in the diagram, the bulb lights and a gas is produced at each electrode.

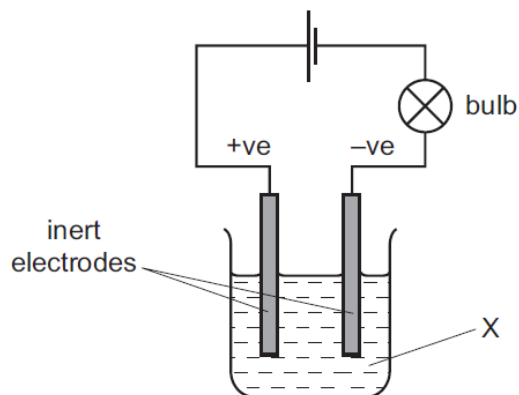

What is X?

- A aqueous copper(II) sulfate
- B concentrated aqueous sodium chloride
- C ethanol
- D molten lead bromide

5070_w12_qp11

11 Which element requires the largest number of electrons for one mole of the metal to be formed from its aqueous ions during electrolysis?

- A aluminium
- B calcium
- C copper
- D sodium

5070_w14_qp11

12 Which changes are observed during the electrolysis of aqueous copper(II) sulfate using copper electrodes?

- 1 A pink solid is deposited on the negative electrode.
- 2 Bubbles form on the positive electrode.
- 3 The colour of the solution does not change.

- A 1 and 2 only B 1 and 3 only C 2 and 3 only D 1, 2 and 3

5070_w14_qp11

19 Which method is used to obtain chlorine from aqueous sodium chloride?

- A crystallisation
- B distillation
- C electrolysis
- D filtration

5070_w14_qp12

12 What is the correct equation for the reaction taking place at the negative electrode when molten magnesium chloride is electrolysed using inert electrodes?

- A $Cl^- \rightarrow Cl + e^-$
- B $2Cl^- \rightarrow Cl_2 + 2e^-$
- C $Mg^+ + e^- \rightarrow Mg$
- D $Mg^{2+} + 2e^- \rightarrow Mg$

5070_w14_qp12

- 8 The experiment shown is used to test potassium bromide crystals.

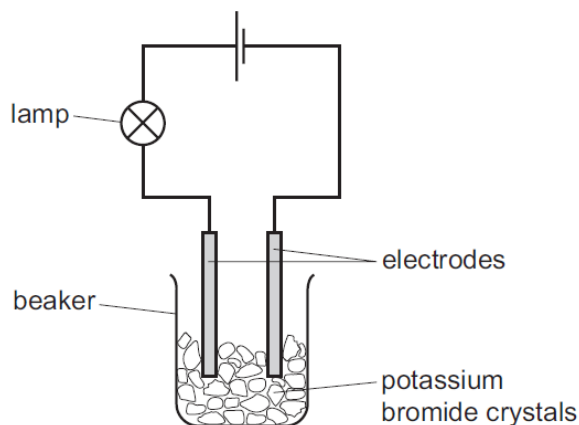

The lamp does not light.

Distilled water is then added to the beaker and the lamp lights.

Which statement explains these results?

- A Electrons are free to move in the solution when potassium bromide dissolves.
- B Metal ions are free to move when potassium bromide melts.
- C Metal ions are free to move when potassium reacts with water.
- D Oppositely charged ions are free to move in the solution when potassium bromide dissolves.

5070_w14_qp12

- 13 How can sodium be manufactured?

- A by electrolysis aqueous sodium chloride
- B by electrolysis aqueous sodium hydroxide
- C by electrolysis molten sodium chloride
- D by heating sodium oxide with carbon

5070_w11_qp11

- 14 Which statement about the electrolysis of an aqueous solution of copper(II) sulfate with platinum electrodes is correct?

- A Oxygen is given off at the positive electrode.
- B The mass of the negative electrode remains constant.
- C The mass of the positive electrode decreases.
- D There is no change in the colour of the solution.

5070_w11_qp11

14 A concentrated aqueous solution of copper(II) chloride is electrolysed using inert electrodes.

What is the product at the positive electrode?

- A chlorine
- B copper
- C hydrogen
- D oxygen

5070_s13_qp12

15 The diagrams show an electrolysis experiment using inert electrodes.

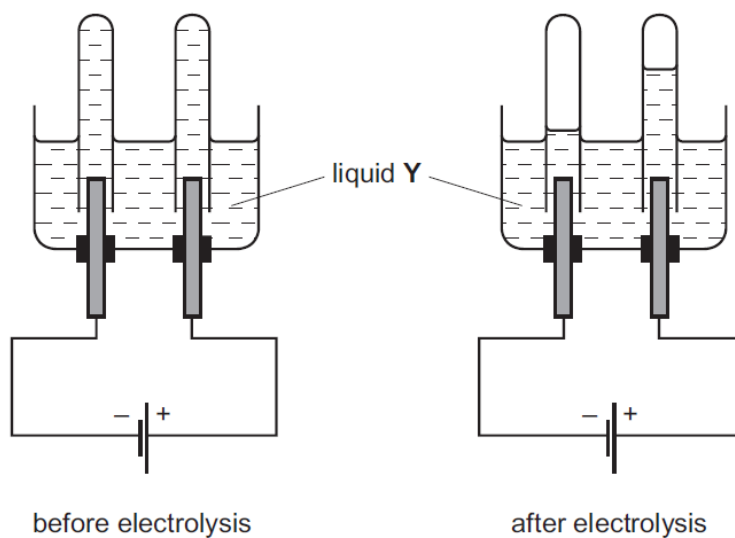

Which could be liquid Y?

- A aqueous copper(II) sulfate
- B concentrated aqueous sodium chloride
- C dilute sulfuric acid
- D ethanol

5070_s13_qp12

28 In the electrolysis of molten aluminium oxide for the extraction of aluminium, the following three reactions take place.

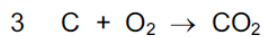
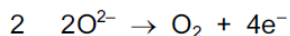
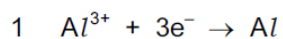

Which reactions take place at the positive electrode?

- A 1 only B 2 only C 1 and 3 only D 2 and 3 only

5070_s13_qp11

13 The diagrams show an electrolysis experiment using inert electrodes.

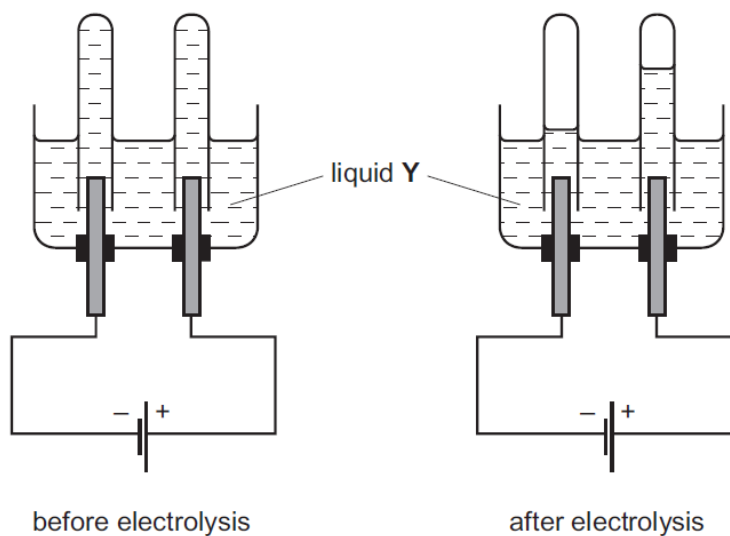

Which could be liquid Y?

- A aqueous copper(II) sulfate
 B concentrated aqueous sodium chloride
 C dilute sulfuric acid
 D ethanol

5070_s13_qp11

- 14 Which substance, when added to water, does **not** make a solution that is a good conductor of electricity?
- A barium nitrate
 - B calcium chloride
 - C lead(II) nitrate
 - D zinc carbonate

5070_s13_qp11

- 9 Which substance conducts an electric current but remains chemically unchanged?
- A aluminium
 - B aqueous sodium chloride
 - C molten lead(II) bromide
 - D pure ethanoic acid

5070_s13_qp11

- 15 Which substance will conduct electricity without being chemically changed?
- A sodium chloride solution
 - B solid iron
 - C solid sodium chloride
 - D solid sulfur

5070_s12_qp12

- 14 Which change **always** takes place when an aqueous solution of copper(II) sulfate is electrolysed?
- A Copper is deposited at the negative electrode.
 - B Oxygen is evolved at the positive electrode.
 - C Sulfate ions move towards the negative electrode.
 - D The colour of the solution fades.

5070_s12_qp12

11 Which statement about conduction of electricity is correct?

- A Electricity is conducted in aqueous solution by electrons.
- B Electricity is conducted in a metal wire by ions.
- C Electricity is conducted in a molten electrolyte by electrons.
- D Electricity is conducted in an acid solution by ions.

5070_s12_qp12

8 In which set of apparatus will the bulb be **least** bright?

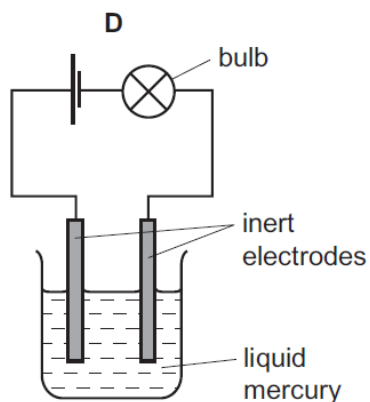
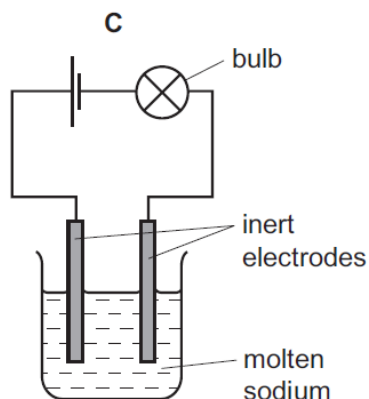
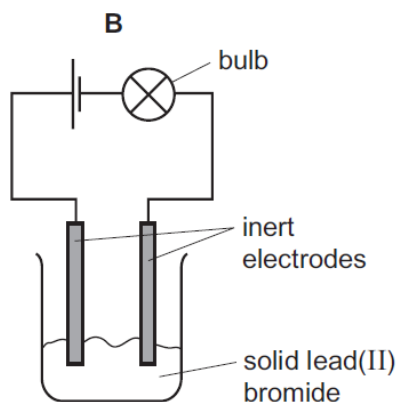
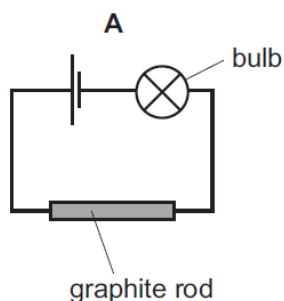

5070_s12_qp12

15 Aqueous copper(II) sulfate is electrolysed using copper electrodes.

Which equation represents the reaction taking place at the anode (positive electrode) in this electrolysis?

- A $\text{Cu(s)} \rightarrow \text{Cu}^{2+}(\text{aq}) + 2\text{e}^{-}$
- B $\text{SO}_4^{2-}(\text{aq}) \rightarrow \text{SO}_2(\text{g}) + \text{O}_2(\text{g}) + 2\text{e}^{-}$
- C $\text{Cu}^{2+}(\text{aq}) + 2\text{e}^{-} \rightarrow \text{Cu(s)}$
- D $4\text{OH}^{-}(\text{aq}) \rightarrow 2\text{H}_2\text{O(l)} + \text{O}_2(\text{g}) + 4\text{e}^{-}$

5070_s12_qp11

13 Which statement about conduction of electricity is correct?

- A Electricity is conducted in aqueous solution by electrons.
- B Electricity is conducted in a metal wire by ions.
- C Electricity is conducted in a molten electrolyte by electrons.
- D Electricity is conducted in an acid solution by ions.

5070_s12_qp11

13 The diagram shows the electrolysis of molten lead(II) bromide using inert electrodes.

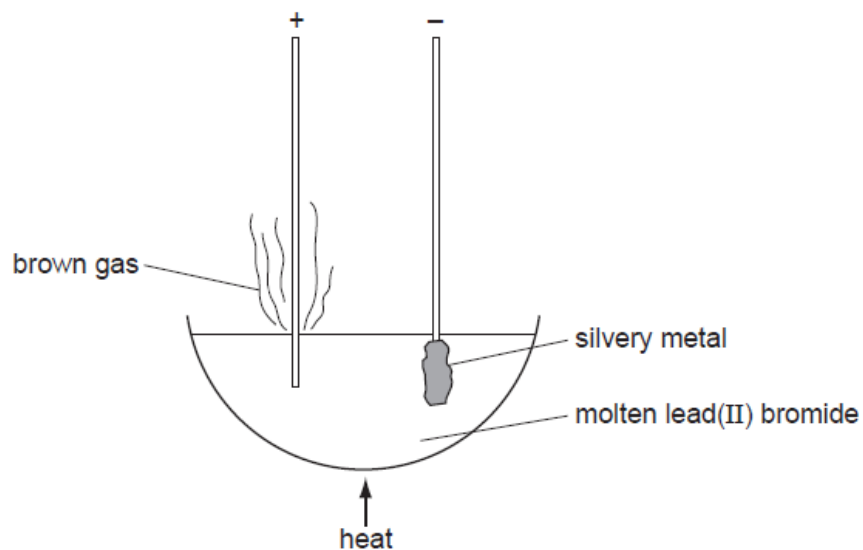

What happens during this electrolysis?

- A Atoms change to ions.
- B Covalent bonds are broken.
- C Ions change to atoms.
- D New compounds are formed.

5070_s11_qp11

12 The diagram shows the results of an electrolysis experiment using inert electrodes.

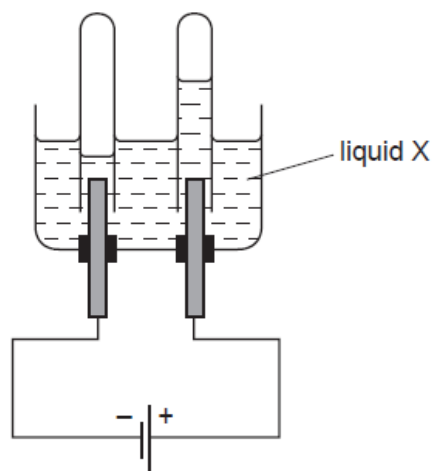

Which could be liquid X?

- A aqueous copper(II) sulfate
- B concentrated aqueous sodium chloride
- C dilute sulfuric acid
- D ethanol

5070_w10_qp11

- 11 The diagram shows the electrolysis of a concentrated aqueous solution containing both copper(II) ions and sodium ions.

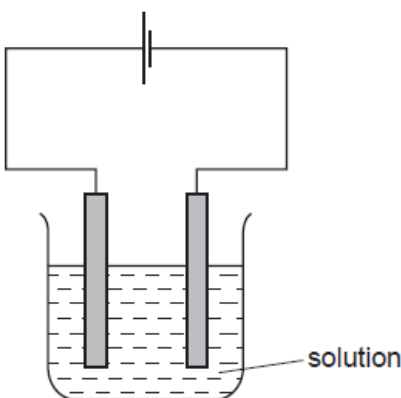

Which metal is deposited at the negative electrode and why?

	metal deposited	reason
A	copper	copper is less reactive than sodium
B	copper	copper is more reactive than hydrogen
C	sodium	copper is less reactive than hydrogen
D	sodium	copper is more reactive than sodium

5070_s10_qp11

- 12 The diagram shows the apparatus used to electrolyse lead(II) bromide using inert electrodes.

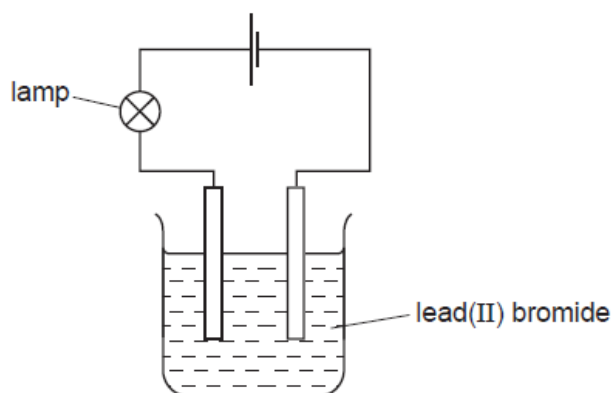

Why does the lamp light up only when the lead(II) bromide is melted?

- A** Bromine atoms in the lead(II) bromide are converted to ions when it is melted.
- B** Electrons flow through the lead(II) bromide when it is melted.
- C** The ions in lead(II) bromide are free to move only when the solid is melted.
- D** There are no ions in solid lead(II) bromide.

5070_s10_qp11

17 Which row in the table describes the processes occurring at the electrodes when molten sodium chloride is electrolysed?

	anode (positive)	cathode (negative)
A	oxidation	reduction
B	reduction	oxidation
C	oxidation	oxidation
D	reduction	reduction

5070_w09_qp1

13 Two cells, P and Q, containing different liquids, were connected in series with a battery, a suitable lamp and inert electrodes, as shown in the diagram.

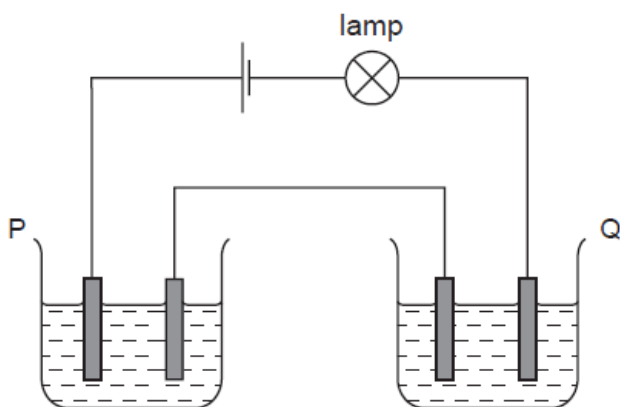

For which pair of liquids did the lamp light up?

	in P	in Q
A	concentrated sodium chloride solution	concentrated sugar solution
B	copper(II) sulfate solution	propanol
C	ethanol	molten lead(II) bromide
D	mercury	dilute hydrochloric acid

5070_w09_qp1

11 What products are formed when concentrated aqueous potassium chloride is electrolysed?

	at the anode (positive)	at the cathode (negative)
A	chlorine	hydrogen
B	chlorine	potassium
C	oxygen	hydrogen
D	oxygen	potassium

5070_w09_qp1

30 Aqueous copper(II) sulphate is electrolysed using inert electrodes as shown.

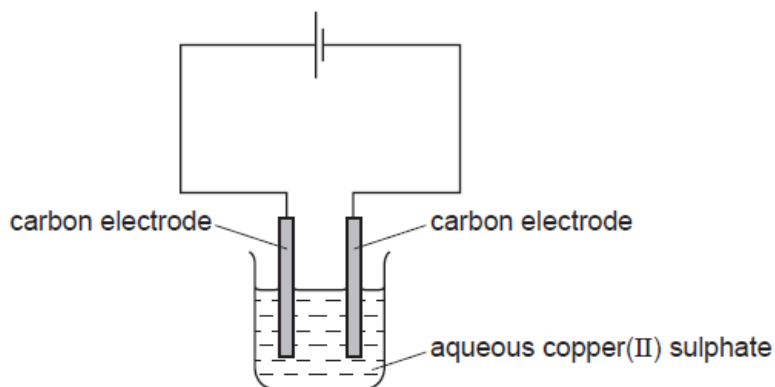

Which ionic equations show the reactions at the electrodes?

- 1 $\text{Cu}^{2+} + 2\text{e}^{-} \rightarrow \text{Cu}$
- 2 $\text{Cu} \rightarrow \text{Cu}^{2+} + 2\text{e}^{-}$
- 3 $2\text{H}^{+} + 2\text{e}^{-} \rightarrow \text{H}_2$
- 4 $4\text{OH}^{-} \rightarrow 2\text{H}_2\text{O} + \text{O}_2 + 4\text{e}^{-}$

A 1 and 2 only **B** 1 and 4 only **C** 2 and 3 only **D** 3 and 4 only

5070_w08_qp1

- 15 When the experiment shown is set up, the bulb lights, but there are no decomposition products at the electrodes.

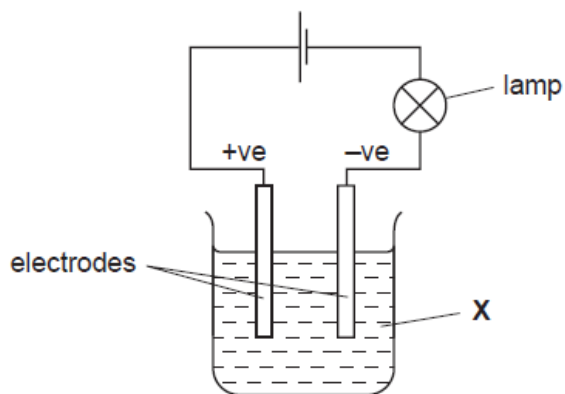

What is X?

- A aqueous sodium chloride
- B bromine
- C molten sodium chloride
- D mercury

5070_w08_qp1

- 16 What are the products formed at the electrodes during the electrolysis of molten magnesium chloride between carbon electrodes?

	positive electrode	negative electrode
A	oxygen	magnesium
B	magnesium	chlorine
C	chlorine	magnesium
D	chlorine	hydrogen

5070_w08_qp1

- 13 Which reactions take place during the electrolysis of aqueous copper(II) sulfate with copper electrodes?

	reaction at positive electrode	reaction at negative electrode
A	$\text{Cu}^{2+} + 2\text{e}^- \rightarrow \text{Cu}$	$\text{Cu} \rightarrow \text{Cu}^{2+} + 2\text{e}^-$
B	$4\text{OH}^- \rightarrow 2\text{H}_2\text{O} + \text{O}_2 + 4\text{e}^-$	$\text{Cu}^{2+} + 2\text{e}^- \rightarrow \text{Cu}$
C	$\text{Cu} \rightarrow \text{Cu}^{2+} + 2\text{e}^-$	$2\text{H}^+ + 2\text{e}^- \rightarrow \text{H}_2$
D	$\text{Cu} \rightarrow \text{Cu}^{2+} + 2\text{e}^-$	$\text{Cu}^{2+} + 2\text{e}^- \rightarrow \text{Cu}$

5070_s09_qp1

14 The diagram shows apparatus used to investigate the conductivity of different solutions.

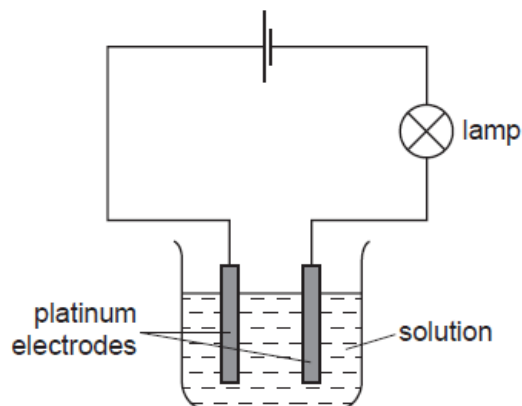

Which substance, in aqueous solution of concentration 1 mol/dm^3 , would cause the lamp to give the brightest light?

- A ammonia
- B ethanoic acid
- C ethanol
- D sulfuric acid

5070_s09_qp1

15 When dilute sulphuric acid is electrolysed between platinum electrodes, which statements are correct?

- 1 Hydrogen is released at the cathode.
- 2 Oxygen is released at the anode.
- 3 Sulphur is released at the anode.
- 4 The acid becomes more dilute.

- A 1 and 2 B 1 and 3 C 2 and 4 D 4 only

s/08/qp1

- 12 A sample of copper contains a metal impurity which is below copper in the reactivity series. The diagram shows the apparatus used for refining the sample.

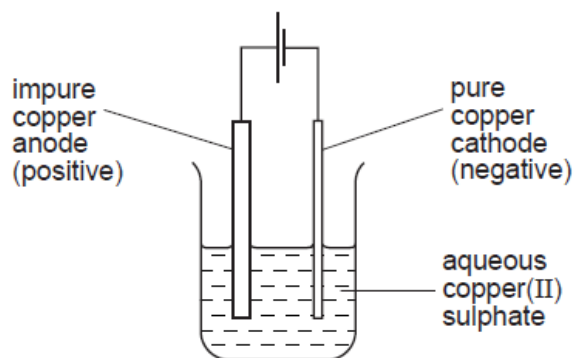

The loss in mass of the anode (positive electrode) is 50 g and the gain in mass of the cathode (negative electrode) is 45 g.

What is the percentage purity of this sample of copper?

- A 10.0% B 11.1% C 90.0% D 95.0%

s/08/qp1

- 9 Why does molten sodium chloride conduct electricity?
- A An electron is completely transferred from sodium to chlorine.
B Sodium ions are only weakly attracted to the chloride ions.
C The electrons in the sodium chloride are free to move.
D The sodium ions and the chloride ions are free to move.

s/08/qp1

13 The diagram shows the electrolysis of aqueous copper(II) sulphate using copper electrodes.

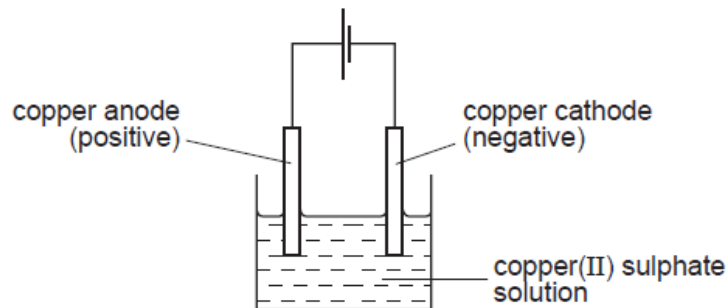

Which graph shows how the mass of the cathode changes during electrolysis?

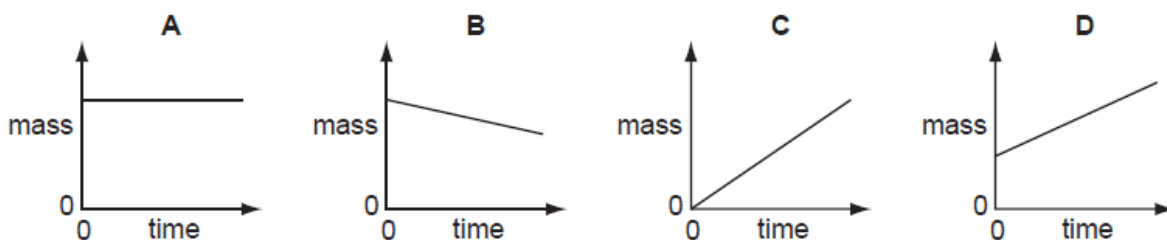

s/07/qp1

14 Which statement is correct about the electrolysis of an aqueous solution of copper(II) sulphate with platinum electrodes?

- A Oxygen is given off at the positive electrode.
- B The mass of the negative electrode remains constant.
- C The mass of the positive electrode decreases.
- D There is no change in the colour of the solution.

w/07/qp1

10 An electrical circuit is set up using copper wire.

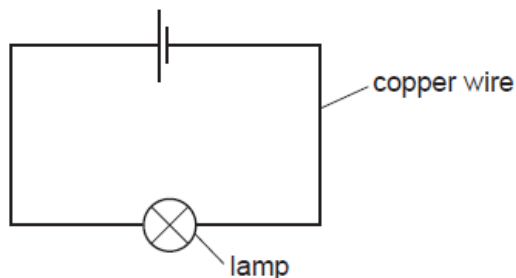

Which process takes place in the copper wire?

- A Electrons move along the wire to the negative terminal, positive ions stay in position.
- B Electrons move along the wire to the positive terminal, positive ions move to the negative terminal.
- C Electrons move along the wire to the positive terminal, positive ions stay in position.
- D Negative ions move along the wire to the positive terminal, positive ions move to the negative terminal.

w/07/qp1

12 Aqueous copper(II) sulphate is electrolysed using copper electrodes.

Which observations will be made?

	at anode (+ve)	at cathode (-ve)	electrolyte
A	anode dissolves	pink solid forms	blue colour fades
B	anode dissolves	pink solid forms	no change
C	colourless gas forms	colourless gas forms	no change
D	colourless gas forms	pink solid forms	blue colour fades

w/06/qp1

17 In which line in the table is all the information correct?

	reaction at electrode	electrode	product
A	$2X^- \rightarrow X_2 + 2e^-$	cathode	metal
B	$X^+ + e^- \rightarrow X$	anode	metal
C	$2X^- \rightarrow X_2 + 2e^-$	anode	non-metal
D	$X^+ + e^- \rightarrow X$	cathode	non-metal

w/05/qp1

- 12 The diagram shows the electrolysis of a concentrated aqueous solution containing both copper(II) ions and sodium ions.

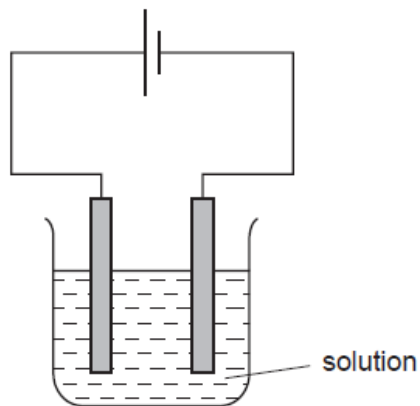

Which metal is deposited at the negative electrode and why?

	metal deposited	reason
A	copper	copper is less reactive than sodium
B	copper	copper is more reactive than hydrogen
C	sodium	copper is less reactive than hydrogen
D	sodium	copper is more reactive than sodium

w/05/qp1

- 14 Dilute sulphuric acid is electrolysed using inert electrodes.

Which equation represents the reaction at the anode (+ve)?

- A $\text{O}_2^{2-} \rightarrow \text{O}_2 + 2\text{e}^-$
 B $2\text{H}^+ + 2\text{e}^- \rightarrow \text{H}_2$
 C $4\text{OH}^- \rightarrow \text{O}_2 + 2\text{H}_2\text{O} + 4\text{e}^-$
 D $\text{SO}_4^{2-} \rightarrow \text{O}_2 + \text{SO}_2 + 2\text{e}^-$

w/04/qp1

15 What are the products when concentrated aqueous lithium chloride is electrolysed?

	at the anode (positive)	at the cathode (negative)
A	chlorine	hydrogen
B	chlorine	lithium
C	oxygen	hydrogen
D	oxygen	lithium

w/04/qp1

16 A solid deposit of element **R** is formed at the cathode(-ve) when an aqueous solution containing ions of **R** is electrolysed.

Which statement about element **R** must be correct?

- A** **R** forms negative ions.
- B** **R** ions gain electrons at the cathode.
- C** **R** ions lose electrons at the cathode.
- D** **R** is above hydrogen in the reactivity series.

w/04/qp1

- 9 The experiment shown is used to test potassium bromide crystals.

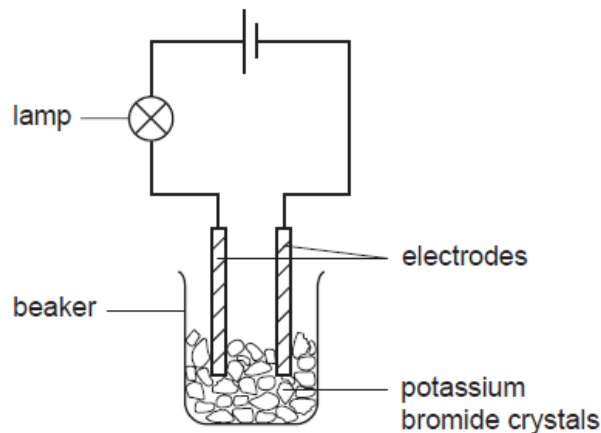

The lamp does not light.

Distilled water is then added to the beaker and the lamp lights.

Which statement explains these results?

- A Electrons are free to move in the solution when potassium bromide dissolves.
- B Metal ions are free to move when potassium bromide melts.
- C Metal ions are free to move when potassium reacts with water.
- D Oppositely charged ions are free to move in the solution when potassium bromide dissolves.

w/04/qp1

- 31 Aqueous copper(II) sulphate is electrolysed using carbon electrodes.

What happens to the electrolyte?

- A It becomes more acidic.
- B It becomes more alkaline.
- C It turns deeper blue.
- D It remains unchanged.

w/03/qp1

- 14 Which of the following, when added to water, makes a solution that is a good conductor of electricity?
- A calcium carbonate
 - B copper
 - C ethanol
 - D sodium hydroxide

w/03/qp1

- 13 Apparatus is set up as shown in the diagram.

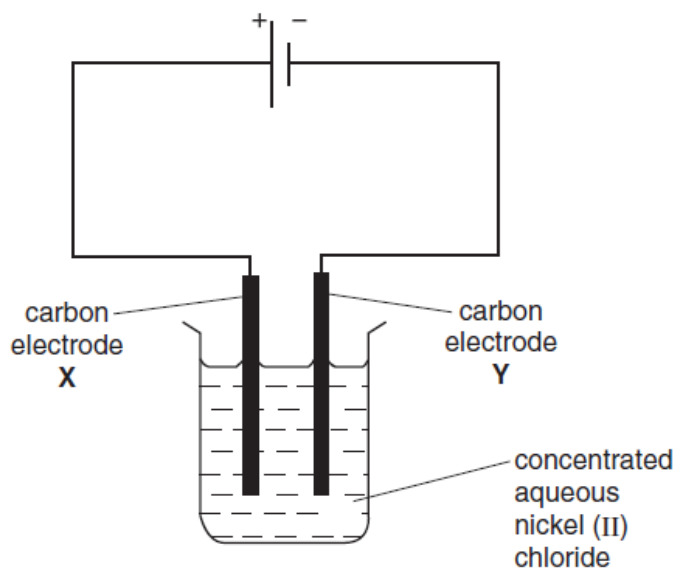

What occurs at electrode X?

- A Chloride ions are oxidised.
- B Chloride ions are reduced.
- C Nickel ions are oxidised.
- D Nickel is deposited.

w/03/qp1

- 34 Which statement describes what happens when hydrogen and oxygen are used in a fuel cell?
- A Electricity is generated directly.
 - B Electricity is used to produce water.
 - C Hydrogen is burned to form steam.
 - D Hydrogen reacts to form a hydrocarbon fuel.

w/02/qp1

- 13 Four electrolytes were electrolysed using carbon electrodes.

Which set of data is correct?

	electrolyte	product at	
		anode	cathode
A	CuSO_4 (aq)	oxygen	copper
B	NaCl (aq)	chlorine	sodium
C	NaH (l)	sodium	hydrogen
D	PbBr_2 (l)	lead	bromine

w/02/qp1

- 18 Which statement about conduction of electricity is correct?
- A Electricity is conducted in aqueous solution by electrons.
 - B Electricity is conducted in a metal wire by ions.
 - C Electricity is conducted in a molten electrolyte by electrons.
 - D Electricity is conducted in an acid solution by ions.

s/06/qp1

12 The apparatus shown below was set up to copper plate the metal spoon.

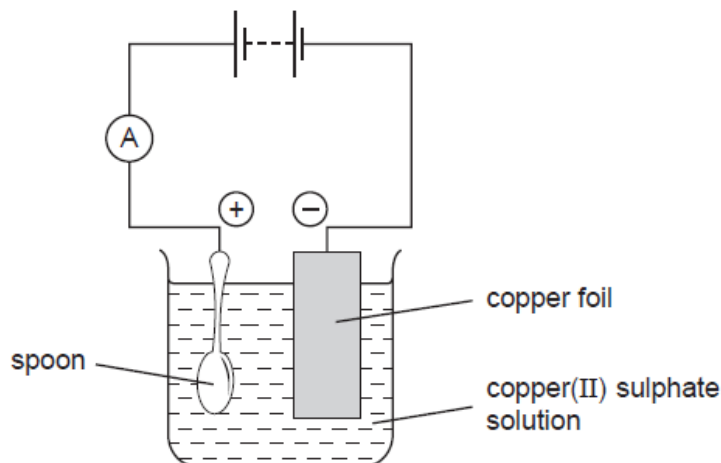

The experiment did **not** work.

What was the mistake in the apparatus?

- A A variable resistor should be included in the electrical circuit.
- B Dilute sulphuric acid should be used as the electrolyte.
- C The copper electrode should all be in the solution.
- D The spoon should be the negative electrode.

s/06/qp1

10 Which reactions take place during the electrolysis of aqueous copper(II) sulphate with copper electrodes?

	reaction at positive electrode	reaction at negative electrode
A	$\text{Cu}^{2+} + 2\text{e}^{-} \rightarrow \text{Cu}$	$\text{Cu} \rightarrow \text{Cu}^{2+} + 2\text{e}^{-}$
B	$4\text{OH}^{-} \rightarrow 2\text{H}_2\text{O} + \text{O}_2 + 4\text{e}^{-}$	$\text{Cu}^{2+} + 2\text{e}^{-} \rightarrow \text{Cu}$
C	$\text{Cu} \rightarrow \text{Cu}^{2+} + 2\text{e}^{-}$	$2\text{H}^{+} + 2\text{e}^{-} \rightarrow \text{H}_2$
D	$\text{Cu} \rightarrow \text{Cu}^{2+} + 2\text{e}^{-}$	$\text{Cu}^{2+} + 2\text{e}^{-} \rightarrow \text{Cu}$

s/05/qp1

11 The heat-reflecting shields of some space rockets are gold-plated, using electrolysis.

Which electrodes and electrolyte would be used to gold-plate the heat shield?

	negative electrode	positive electrode	electrolyte
A	carbon	heat shield	gold compound
B	gold	heat shield	copper compound
C	heat shield	carbon	copper compound
D	heat shield	gold	gold compound

s/05/qp1

16 A current was passed through concentrated aqueous potassium chloride, KCl , as shown.

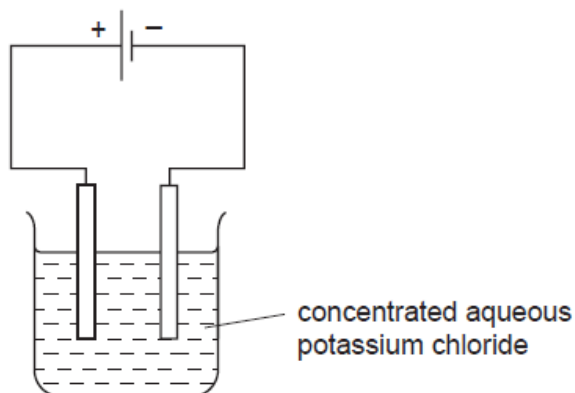

Which entry in the table is correct?

	ions moving towards	
	the cathode (-ve)	the anode (+ve)
A	K^+ only	Cl^- and OH^-
B	K^+ only	Cl^- only
C	K^+ and H^+	Cl^- only
D	K^+ and H^+	Cl^- and OH^-

s/04/qp1

- 17 When the experiment shown was set up, the bulb lit, but there were no decomposition products at the electrodes.

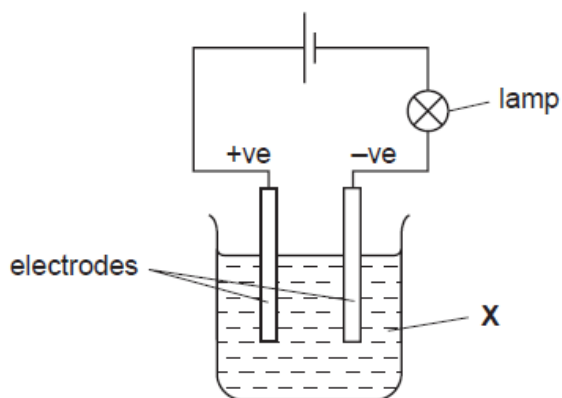

What is X?

- A aqueous sodium chloride
- B bromine
- C molten sodium chloride
- D mercury

s/04/qp1

- 11 In the circuit below, the lamp lights up.

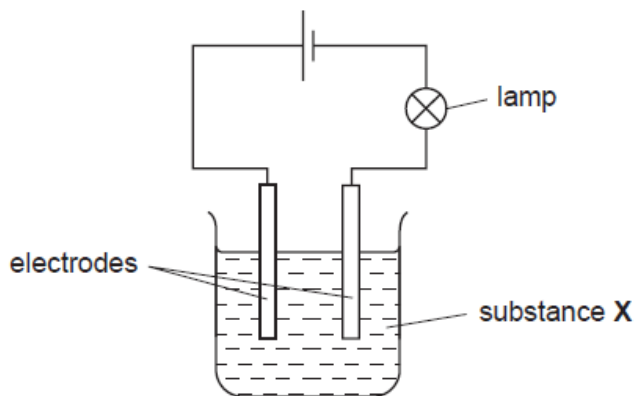

What could X be?

- A a solution of ethanol in water
- B a solution of sodium chloride in water
- C liquid ethanol
- D solid sodium chloride

s/04/qp1

14 A piece of metal is to be electroplated.

Which set of conditions give the thickest plate?

	type of current	size of current	time
A	a.c.	low	short
B	d.c.	high	long
C	a.c.	high	short
D	d.c.	low	long

s/03/qp1

15 Rubidium is above sodium in the reactivity series.

What is formed when concentrated aqueous rubidium chloride is electrolysed?

products		
	cathode (-)	anode (+)
A	chlorine	hydrogen
B	hydrogen	rubidium
C	hydrogen	chlorine
D	rubidium	chlorine

s/03/qp1

THEORY QUESTIONS

- (d) The electrode reactions occurring when molten sodium chloride is electrolysed are shown below.

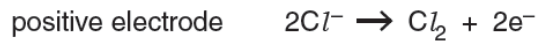

Refer to these equations to explain why this electrolysis involves both oxidation and reduction.

.....
.....
.....[2]

- (e) Chlorine reacts with excess ammonia, NH_3 , to form hydrogen chloride and nitrogen. Construct an equation for this reaction.

.....[1]

w/14/qp22

A4 The diagram shows a simple electrochemical cell.

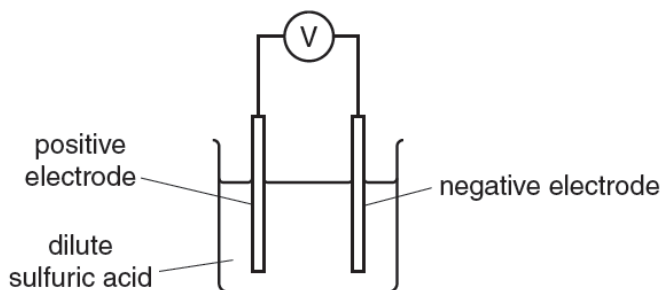

The voltages produced by different combinations of metal electrodes are shown in the table below. The more reactive metal is always the negative electrode.

positive electrode	negative electrode	voltage/V
copper	zinc	1.10
copper	tin	0.48
copper	magnesium	2.70
copper	iron	0.78
silver	copper	0.46

(a) (i) Write an equation showing the conversion of zinc to zinc ions.
[1]

(ii) How does the table above show that copper is above silver in the reactivity series?

[1]

(iii) Which combination of metals in the table above will give the highest voltage?
[1]

(iv) Use the information in the table to deduce the order of reactivity of the metals copper, iron, magnesium, tin and zinc. Explain your answer.

most reactive
 ↑

 least reactive

[2]

(d) (i) Name the products formed at the anode and cathode when molten calcium chloride is electrolysed.

anode

cathode [1]

(ii) Predict the product formed at the cathode when a dilute aqueous solution of calcium chloride is electrolysed.

..... [1]

(iii) Explain why solid calcium chloride does not conduct electricity.

..... [1]

w/13/qp21

A4 Only liquids that contain moving ions can be electrolysed. These liquids are called electrolytes.

(a) Complete the following table which shows the products formed when some liquids are electrolysed using inert graphite electrodes.

electrolyte	ions present in electrolyte	product formed at the positive electrode	product formed at the negative electrode
aqueous copper(II) sulfate	Cu^{2+} , H^+ , OH^- and SO_4^{2-}
concentrated aqueous sodium chloride	H^+ , Na^+ , Cl^- and OH^-	chlorine	hydrogen
molten lead(II) bromide	Pb^{2+} and Br^-

[3]

(b) When concentrated aqueous sodium chloride is electrolysed, chlorine is formed at the positive electrode (anode) and hydrogen at the negative electrode (cathode).

(i) Construct the ionic equation to show the formation of chlorine at the positive electrode.

.....[1]

(ii) Explain why hydrogen is formed at the negative electrode rather than sodium.

.....
[1]

(c) Name a metal manufactured by the electrolysis of a molten ionic compound.

.....[1]

[Total: 6]

s/14/qp22

(b) (i) Explain why pure sodium chloride can be electrolysed at 1000 °C but not at 600 °C.

.....

 [2]

(ii) Construct an equation for the anode reaction in the electrolysis of pure sodium chloride at 1000 °C.

..... [1]

s/13/qp22

B10 Aqueous silver nitrate can be electrolysed using inert electrodes.
Solid silver is formed on the cathode (negative electrode).

The table shows how the mass of silver formed is affected by four factors.

temperature of solution /°C	duration of electrolysis /seconds	current passed through solution/amps	concentration of solution /mol/dm ³	mass of silver formed /g
25	100	9.65	1.0	0.108
30	100	9.65	1.0	0.108
25	100	9.65	0.5	0.108
25	200	9.65	0.5	0.216
25	100	19.3	1.0	0.216

(a) The electrode reaction at the cathode is reduction.

(i) Construct the equation for the reaction which occurs at the cathode.

..... [1]

(ii) Explain why this reaction is reduction.

.....
..... [1]

(b) State how each of the following factors affects the mass of silver formed at the cathode.

temperature of solution

.....
.....

duration of electrolysis

.....
.....

current used

.....
.....

concentration of solution

.....
.....

(c) Explain why aqueous silver nitrate can be electrolysed but solid silver nitrate cannot.

.....
.....
..... [2]

(d) Aqueous silver nitrate reacts with dilute hydrochloric acid to form a white precipitate.

Construct the ionic equation, including state symbols, for the formation of this white precipitate.

..... [2]

[Total: 10]

s/13/qp21

(d) The electrode reactions in an oxygen-hydrogen fuel cell are shown below.

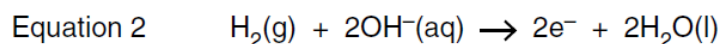
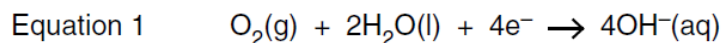

Explain why the reaction in a fuel cell involves both oxidation **and** reduction.

.....
.....
.....
..... [2]

(e) Name one source of the hydrogen needed for a fuel-cell.

..... [1]

(f) State one advantage and one disadvantage of using an oxygen-hydrogen fuel cell.

advantage

.....

disadvantage

..... [2]

s/12/qp22

A5 The diagram below shows the apparatus used to electrolyse aqueous sodium hydroxide in the laboratory.

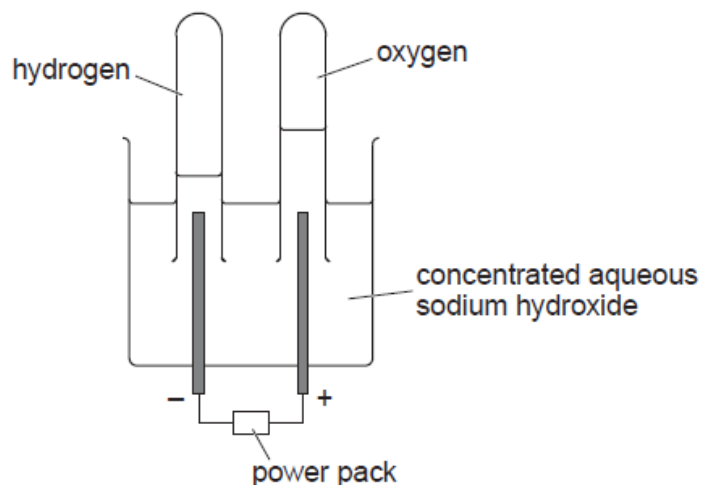

Electrolysis of the aqueous sodium hydroxide, results in the formation of hydrogen at the cathode (negative electrode) and oxygen at the anode (positive electrode).

(a) Complete the equation for the formation of oxygen at the anode.

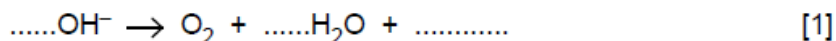

(b) (i) When the power pack is replaced by a voltmeter, the apparatus acts like a fuel cell. The left hand electrode in the diagram becomes the negative pole of the cell and the right hand electrode becomes the positive pole.

State the direction of the electron flow in the external circuit.
Give a reason for your answer.

.....
..... [1]

(ii) In this fuel cell, hydrogen reacts with aqueous hydroxide ions to form water. Construct an equation for this reaction.

[1]

(c) (i) Suggest two advantages of using a fuel cell rather than petrol to power a car.

.....
.....
..... [2]

(ii) Suggest one disadvantage of fuel cells.

..... [1]

[Total: 6]

w/12/qp21

A5 Nickel can be refined by reacting the impure metal with carbon monoxide. The impurities do not react with carbon monoxide.

A volatile compound called nickel carbonyl is formed.

This is decomposed to give pure nickel and carbon monoxide.

(a) (i) Explain the meaning of the term *volatile*.

..... [1]

(ii) Suggest how nickel carbonyl might be decomposed.

..... [1]

(iii) Explain how this method separates nickel from its impurities.

..... [1]

(b) Nickel carbonyl has the formula $\text{Ni}(\text{CO})_x$.

The relative molecular mass of nickel carbonyl is 171.

Calculate the value of x .

value of x = [1]

(c) Nickel is refined by electrolysis in a similar way to copper.

Draw a labelled diagram of the apparatus you would use to purify nickel by electrolysis in the laboratory.

[4]

(d) Nickel is a metal.

State three physical properties shown by **all** metals.

.....

.....

..... [3]

w/12/qp22

B7 Sulfuric acid is a strong acid. Ethanoic acid is a weak acid.

(a) What do you understand by the terms *strong acid* and *weak acid*?

.....
.....
..... [1]

(b) Compare and explain the difference in the electrical conductivity between a strong and a weak acid.

..... [1]

(c) A dilute solution of sulfuric acid contains hydrogen ions, hydroxide ions and sulfate ions. When this solution is electrolysed, hydrogen gas is formed at the cathode and oxygen gas is formed at the anode.

(i) Explain why hydrogen is formed at the cathode.

.....
..... [1]

(ii) Write the ionic equation for the reaction at the anode.

..... [2]

w/11/qp22

(d) The electrode reactions in an oxygen-hydrogen fuel cell are shown below.

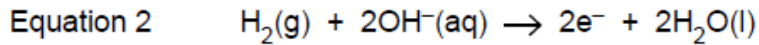
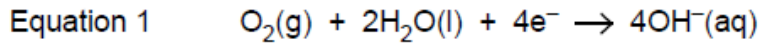

Explain why the reaction in a fuel cell involves both oxidation and reduction.

.....
.....
.....
..... [2]

(e) Name one source of the hydrogen needed for a fuel-cell.

..... [1]

(f) State one advantage and one disadvantage of using an oxygen-hydrogen fuel cell.

advantage

.....

disadvantage

..... [2]

[Total: 10]

w/12/qp22

B8 Solid sodium hydroxide, NaOH, has a giant ionic structure.

(a) How many electrons are there in one hydroxide ion?

..... [1]

(b) Explain why solid sodium hydroxide cannot be electrolysed but aqueous sodium hydroxide can be electrolysed.

.....

.....

..... [2]

(c) The electrolysis of aqueous sodium hydroxide produces hydrogen and oxygen as shown by the electrode reactions.

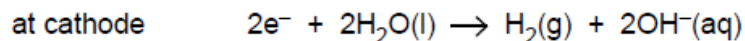
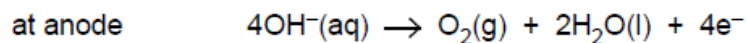

Explain why the electrolysis of aqueous sodium hydroxide involves both oxidation and reduction.

.....

.....

.....

..... [2]

s/12/qp21

B7 Zinc chloride is an ionic solid. It can be electrolysed using the apparatus shown below.

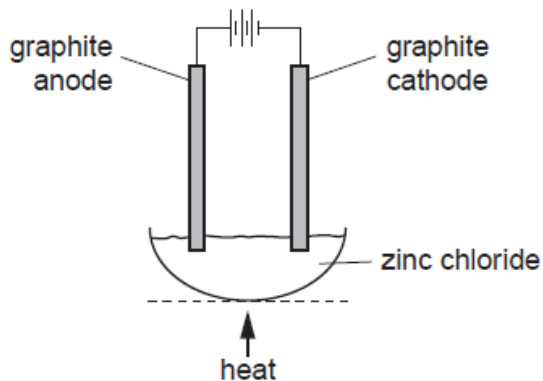

(a) Explain why zinc chloride conducts electricity when molten, but not when solid.

.....
..... [2]

(b) Predict the products of this electrolysis at

the anode,

the cathode. [1]

(c) When a dilute aqueous solution of zinc chloride is electrolysed, hydroxide ions are converted to oxygen at the anode. Write the ionic equation for this reaction.

[2]

(d) Describe a positive test for zinc ions.

test

observations

..... [3]

w/10/qp22

A5 A student electrolysed an aqueous solution of potassium bromide using carbon electrodes.

(a) Draw a labelled diagram of a suitable apparatus that can be used for this electrolysis.

[2]

(b) The ions present in an aqueous solution of potassium bromide are H^+ , OH^- , K^+ and Br^- .

(i) Describe what you would observe in the region of the anode during the electrolysis.

..... [1]

(ii) At the cathode, hydrogen gas is given off.

Describe a test for hydrogen.

test

result [2]

(iii) Write an equation for the reaction at the cathode.

..... [1]

(iv) Explain why potassium is not discharged at the cathode.

.....

..... [1]

[Total: 7]

w/10/qp21

B9 Electrolysis can be used to remove unwanted hair. The customer holds a metal bar which acts as a positive electrode. A needle, which acts as the negative electrode, is held by the operator.

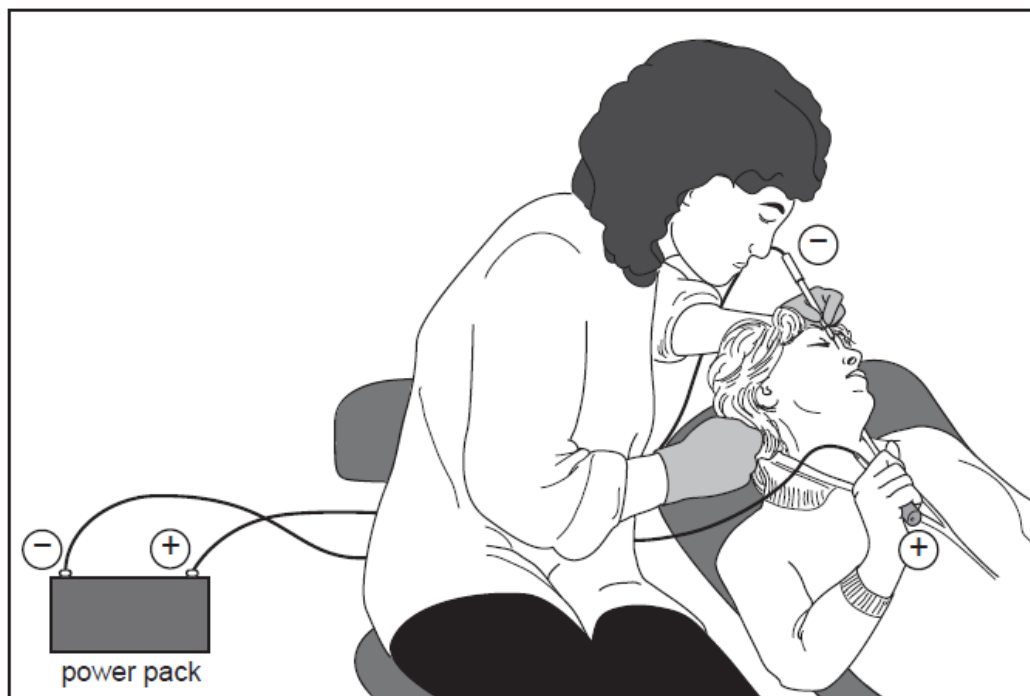

- (a) What do you understand by the term *electrolysis*? [1]
- (b) The solution around the tip of the needle is mainly a dilute aqueous solution of sodium chloride.

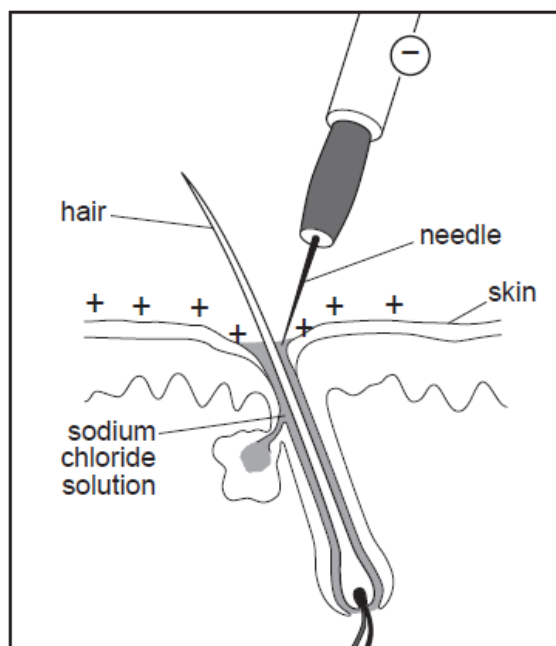

- (i) Name all the ions present in the solution during this electrolysis. [1]
- (ii) During electrolysis a small amount of chlorine is formed at the surface of the skin. Write an ionic equation for this reaction. [1]
- (iii) During electrolysis, a gas forms at the tip of the needle and the solution changes from pH 7 to pH 10. Explain both these changes. [2]
- (c) Explain why aqueous sodium chloride solution conducts electricity but solid sodium chloride does not. [2]

w/08/qp2

B9 One of the first buses to use hydrogen as a fuel was operated in Erlangen, Germany, in 1996. The hydrogen was stored in thick pressurised tanks on the roof of the bus.

- (a) Describe two advantages of using hydrogen as a fuel rather than petrol. [2]
- (b) Suggest one disadvantage of using hydrogen as a fuel. [1]
- (c) Some buses use hydrogen to generate electrical energy from a fuel cell. The structure of a typical fuel cell is shown.

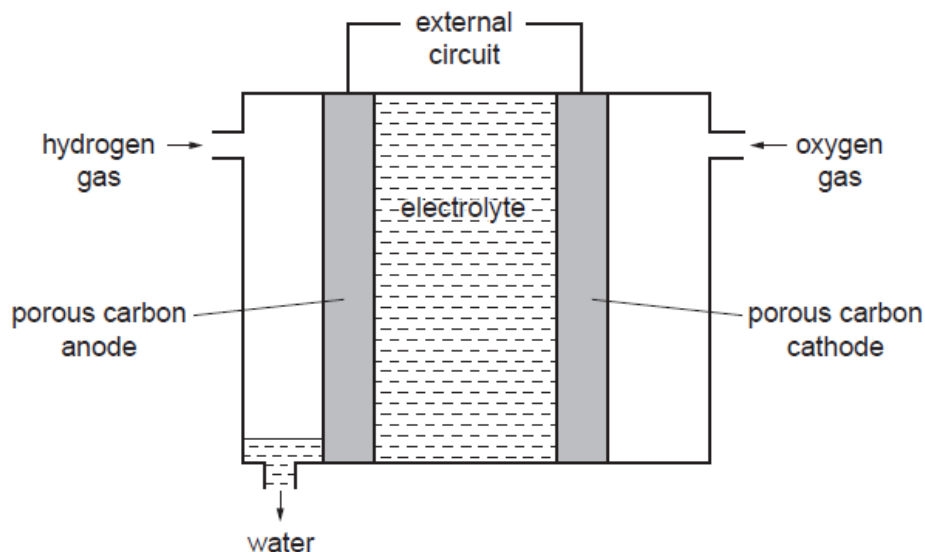

- (i) The equation for the reaction at the anode is shown.

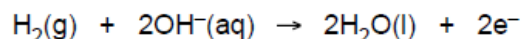

What type of reaction is this? Explain your answer. [1]

- (ii) At the cathode oxygen reacts with water to form hydroxide ions. Write an ionic equation for this reaction. [1]

- (d) In some fuel cells an acidic electrolyte is used.

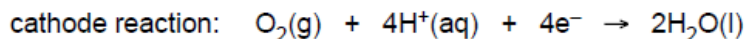
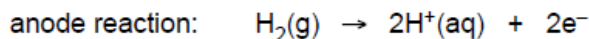

- (i) Write an overall equation for the reaction occurring in this fuel cell. [1]
- (ii) Suggest a suitable electrolyte for this fuel cell. [1]

- (e) An electric current can also be generated by a simple electrochemical cell such as the one shown.

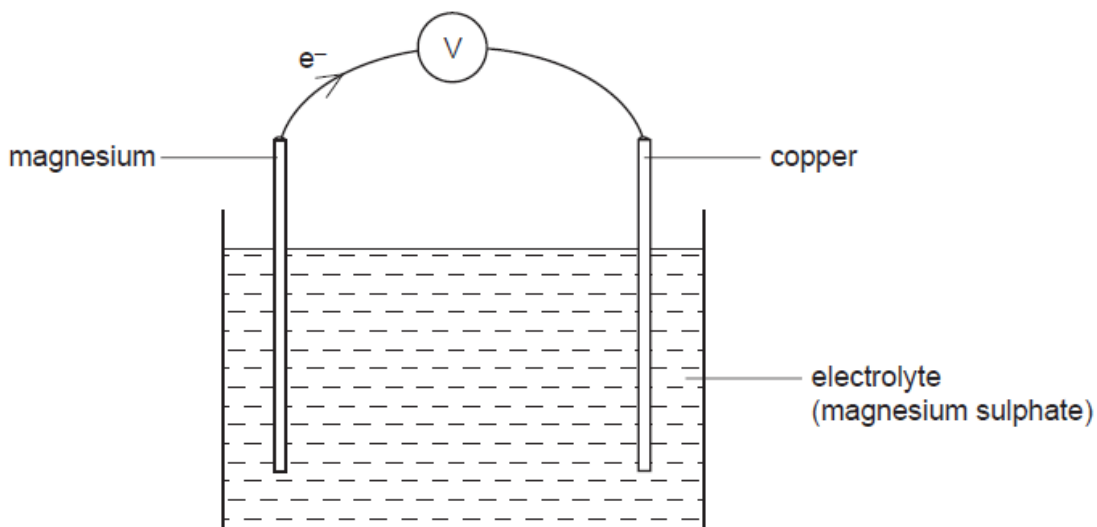

- (i) Explain why the flow of electrons is in the direction shown in the diagram. [2]
(ii) Suggest why silver nitrate would not be a good electrolyte to use in this cell. [1]

[Total: 10]

w/07/qp2

B10 The diagram shows a cell for purifying copper.

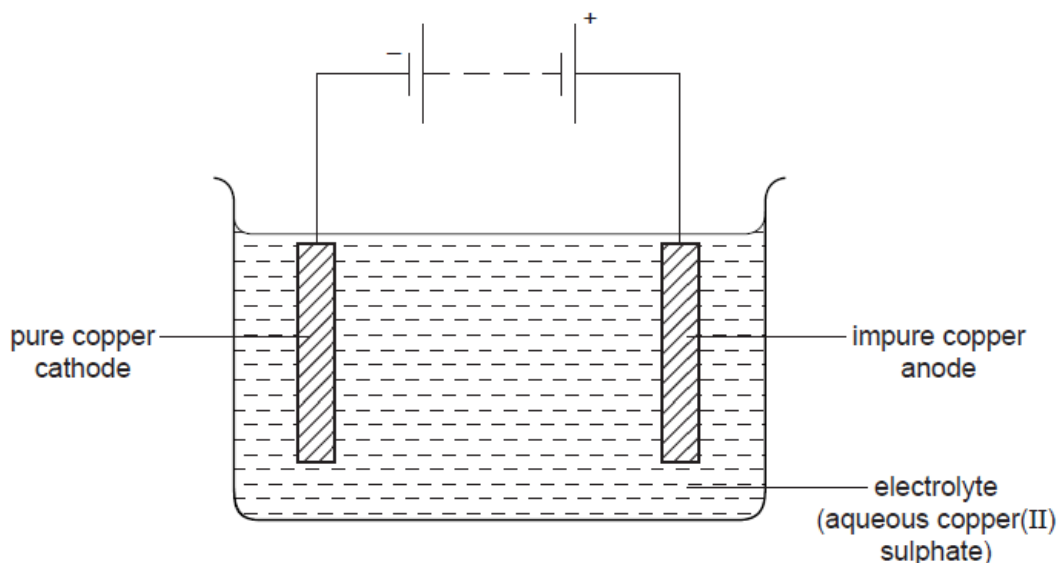

- (a) Describe what you would observe during this electrolysis and write the equations for the reactions at the electrodes. [3]
- (b) The electrodes and the electrolyte conduct electricity.
- (i) Explain how the structure of metals allows copper electrodes to conduct electricity. [1]
- (ii) Explain why solid copper(II) sulphate does not conduct electricity but an aqueous solution of copper(II) sulphate does conduct. [2]
- (c) Describe how the apparatus shown in the diagram could be modified in order to electroplate an iron object, such as a knife, with nickel. [2]
- (d) Bronze is an alloy of copper and tin. Bronze is less malleable than pure copper. Use ideas about the structure of metals and alloys to explain why bronze is less malleable than pure copper. [2]

w/06/qp2

B10 A student carried out an electrolysis of dilute sulphuric acid and collected the gases formed.

- (a) Draw a labelled diagram to show the apparatus used. [2]
- (b) (i) Give the formulae of all the ions present in the solution.
(ii) Write half equations for the reactions at the anode and cathode. Use the half equations to construct an overall equation for the reaction and give tests for any gases evolved.
(iii) Use your equations to explain how the composition of the solution changes after the electrolysis has been running for some time. [6]
- (c) Describe another method for making hydrogen from dilute sulphuric acid. Your answer should include names of the reagents you use and an equation for the reaction. [2]

[Total: 10 marks]

w/05/qp2

B10 Electroplating can be used to coat nickel with a thin coating of silver.

- (a) Draw a labelled diagram of an apparatus that can be used to electroplate silver onto nickel. [3]
- (b) Write equations, with state symbols, for the reactions at the anode and cathode. [2]
- (c) Solutions of two salts, **A** and **B**, were electrolysed using carbon electrodes. The following products were collected.

<i>salt</i>	<i>products</i>
A	oxygen and hydrogen
B	chlorine and hydrogen

- (i) Suggest the names of the two salts, **A** and **B**.
(ii) Describe tests to confirm the identifies of the three gases collected. [5]

[Total: 10 marks]

w/04/qp2

(b) Chlorine is manufactured by the electrolysis of concentrated sodium chloride.

- (i) Write equations for both of the electrode reactions.
- (ii) Calculate the maximum volume of chlorine, at r.t.p., which can be obtained from 175.5 kg sodium chloride.

[5]

w/01/qp2

A1 (a) A student tried to pass an electric current through some solids and liquids. The six experiments are represented by the diagrams below.

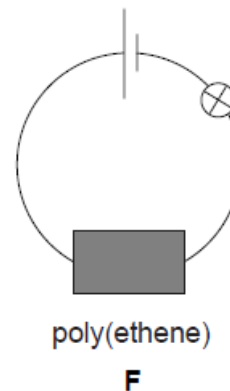
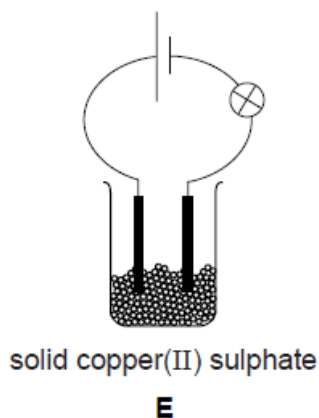
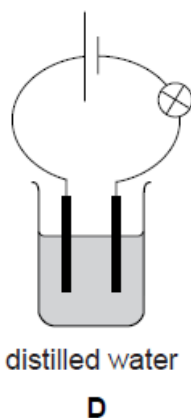
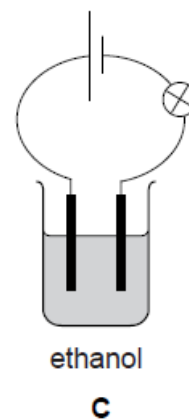
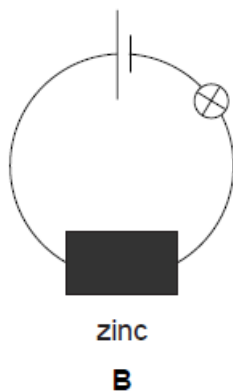
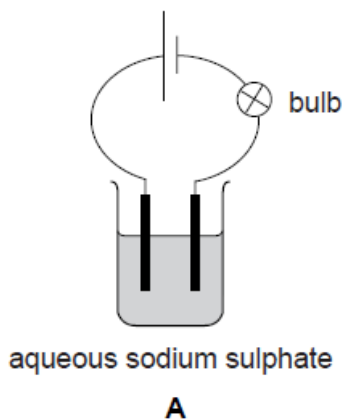

- (i) In which experiments will the bulb light?
.....[2]
- (ii) Give the name of an electrolyte shown in the diagram.
.....[1]
- (iii) In which experiment will oxygen be produced?
.....[1]

(b) The following diagram represents the electrolysis of molten substance, X.

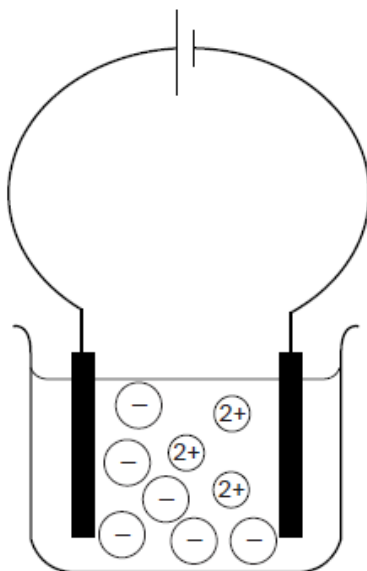

(i) Label the anode and cathode on the diagram.

(ii) Suggest the name of substance X.

.....

(iii) State the formula of the cation in X.

.....

(iv) Explain why substance X conducts electricity when molten, but not when solid.

.....

.....

.....

[5]

w/01/qp2

B8 Aqueous copper(II) sulphate is electrolysed using carbon electrodes.

(a) Give the formulae of all the ions present in the solution. [2]

(b) A copper coating forms on the cathode, and a gas is evolved at the anode.

(i) Write a half equation for the formation of copper at the cathode.

(ii) Name the gas formed at the anode and describe a test for this gas. [3]

(c) After some time, the blue colour of the aqueous copper(II) sulphate fades and the pH of the solution decreases.

Explain why these changes take place. [2]

- (d) A student investigated the relationship between the mass of copper formed and the total charge passed through the solution.

This is a graph of the results.

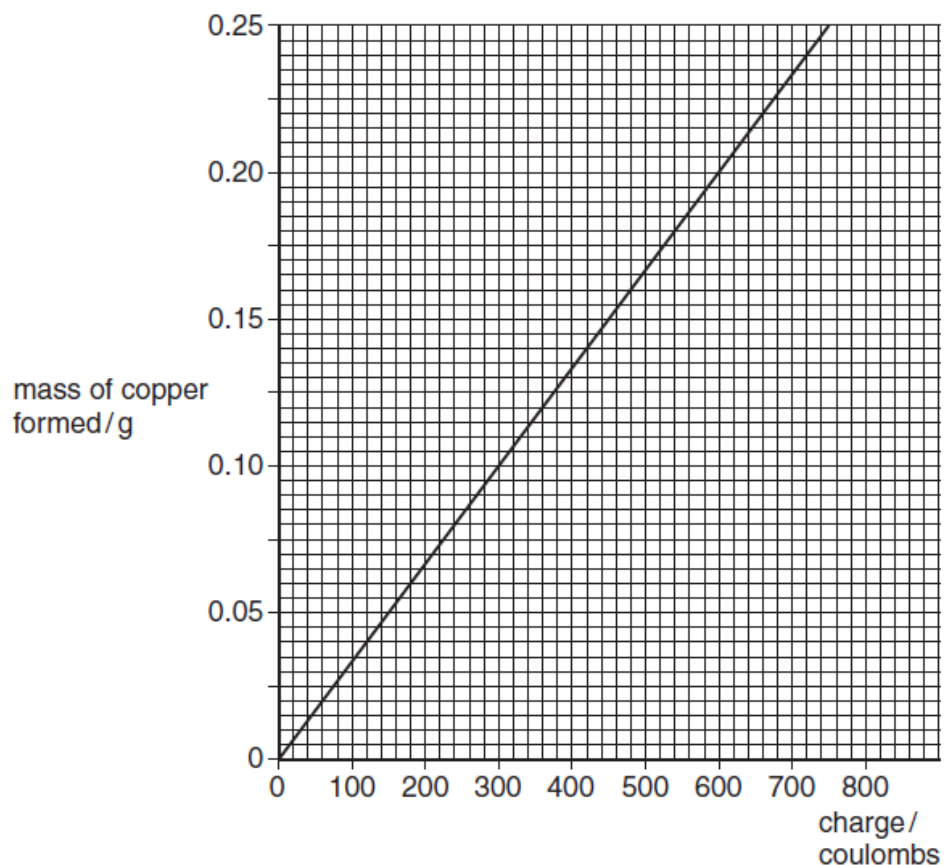

- (i) What mass of copper is formed when a charge of 600 coulombs is passed through the solution?
- (ii) Use your graph to predict the charge needed to form 1 g of copper, and hence predict the charge needed to deposit 1 mole of copper.

[3]

[Total : 10]

w/02/qp2

(ii) Describe how impure copper can be purified.

.....
.....
.....
.....[2]

(c) Name an alloy that contains copper.

.....[1]

s/11/qp22

B6 Electrolysis involves the chemical decomposition of a compound, either when molten or in aqueous solution, by the passage of an electric current.

(a) Explain why aqueous calcium nitrate can be electrolysed but liquid pentane cannot.

.....
.....
.....
.....[2]

(b) State the products of the electrolysis of molten sodium chloride.

.....[1]

(c) State the products of the electrolysis of concentrated aqueous sodium chloride.

.....[1]

(d) Describe the essential details of the manufacture of aluminium by electrolysis.

.....
.....
.....
.....[2]

- (e) A student investigates the electrolysis of aqueous copper(II) sulfate using the apparatus shown below.

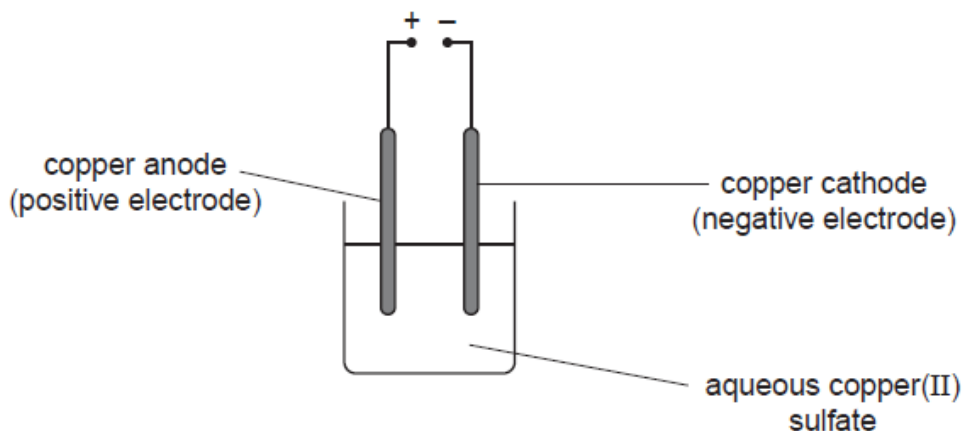

The student weighs the copper cathode before and after the electrolysis.

experiment number	current used / A	time taken / s	mass of cathode	
			before starting / g	after electrolysis / g
1	2.0	180	1.24	1.36
2	4.0	180	1.20	1.44
3	2.0	360	1.34	1.58

- (i) Explain, with the aid of an equation, why the cathode increases in mass.

.....

[2]

- (ii) In experiment 2 the student measures the mass of the anode both before and after the electrolysis.

At the start the anode has a mass of 1.45 g.

Determine the mass of the anode at the end of the electrolysis.

mass of anode at end = g [1]

- (iii) The student does a fourth experiment, this time using a current of 8.0A for 90 seconds. At the start the cathode has a mass of 1.51 g. Predict the mass of the cathode at the end of the electrolysis.

mass of cathode at end = g [1]

[Total: 10]

s/11/qp21

- (c) The copper used in mobile phones is purified using electrolysis.

For this electrolysis name

the electrolyte used,

the material used for the anode,

the material used for the cathode. [3]

s/10/qp21

A3 Electrolysis involves the decomposition of a compound by the passage of an electric current.

(a) (i) Complete the table, which relates to the electrolysis of different solutions using inert electrodes.

electrolyte	ions in electrolyte	product at anode	product at cathode
dilute aqueous potassium nitrate	K^+ , H^+ , OH^- and NO_3^-	oxygen	hydrogen
concentrated aqueous sodium chloride	Na^+ , H^+ , OH^- and Cl^-	chlorine	hydrogen
dilute aqueous copper(II) sulfate	Cu^{2+} , SO_4^{2-} , H^+ and OH^-
dilute sulfuric acid	oxygen	hydrogen

[3]

(ii) Explain why the electrolysis of concentrated aqueous sodium chloride liberates hydrogen rather than sodium at the cathode.

.....
..... [1]

(iii) The electrolysis of **dilute** aqueous sodium chloride liberates oxygen at the anode. Suggest why the electrolysis of **concentrated** aqueous sodium chloride liberates chlorine rather than oxygen.

.....
..... [1]

(b) Aqueous copper(II) sulfate was electrolysed using copper electrodes. The copper anode lost mass as copper(II) ions were formed and the copper cathode gained mass as copper atoms were formed.

(i) State one industrial application of this electrolysis.

..... [1]

(ii) The results of an experiment involving the electrolysis of aqueous copper(II) sulfate are shown below.

temperature of electrolyte / °C	current used / amps	time of electrolysis / s	mass of copper formed at the cathode / g
20	1.0	1000	0.329
20	2.0	1000	0.658
20	2.0	2000	1.320
25	2.0	2000	1.320
30	1.0	1000	0.329

Use the information in the table to describe how each of the variables affects the mass of copper formed at the cathode.

temperature

.....

current

.....

time

..... [3]

[Total: 9]

s/09/qp2

(c) Complete the following table about electrolysis using inert graphite electrodes.

electrolyte	product at cathode	product at anode
molten lead(II) bromide		
aqueous copper(II) sulfate	copper	
dilute sulfuric acid		oxygen

[3]

(d) Describe one commercial use of electrolysis.

use

electrolyte used

ionic equation for reaction at the cathode

[3]

s/10/qp22

A5 (a) Concentrated aqueous sodium chloride contains H^+ and OH^- ions.

(i) Give the formulae of **two** other ions present in concentrated aqueous sodium chloride.

.....[1]

(ii) Concentrated aqueous sodium chloride is electrolysed using inert graphite electrodes.

Name the product formed at each electrode.

product at anode

product at cathode[2]

(b) Impure copper can be purified by electrolysis.

Draw a labelled diagram of the electrolytic cell that can be used to purify copper.

[3]

s/07/qp2

A5 Chlorine, hydrogen and sodium hydroxide are made by the electrolysis of concentrated aqueous sodium chloride.

(a) Aqueous sodium chloride contains the following ions, Na^+ , H^+ , OH^- and Cl^- .

Concentrated aqueous sodium chloride can be electrolysed using inert electrodes.

The electrode reactions are represented below.

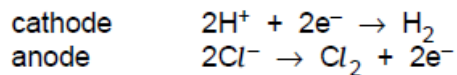

(i) Explain why hydrogen, **not** sodium, is formed at the cathode.

.....
.....

(ii) Suggest why, as the electrolysis proceeds, the concentration of sodium hydroxide in the electrolyte increases.

.....
.....

[2]

s/05/qp2

A5 Electrolysis is the decomposition of a liquid by the passage of an electrical current.

- (a) Aqueous copper(II) sulphate contains the following ions, Cu^{2+} , H^+ , OH^- and SO_4^{2-} .
Aqueous copper(II) sulphate can be electrolysed using inert electrodes.

The electrode reactions are represented below.

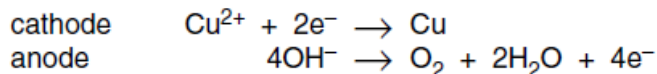

- (i) Explain why copper, **not** hydrogen, is formed at the cathode.

.....
.....

- (ii) Explain why the formation of oxygen at the anode is an example of oxidation.

.....
.....

- (iii) The electrolysis of aqueous copper(II) sulphate using copper electrodes has a different anode reaction.
Give the equation for the electrode reaction at the anode.

.....

[3]

- (b) Molten lead(II) bromide decomposes when an electric current is passed through it.

- (i) Explain why solid lead(II) bromide will not conduct electricity but molten lead(II) bromide will.

.....
.....
.....

- (ii) Construct the equations for the two electrode reactions.

cathode

anode

[4]

s/04/qp2

- B8** The NASA space shuttle uses fuel cells to generate electricity. The diagram below shows a hydrogen-oxygen fuel cell.

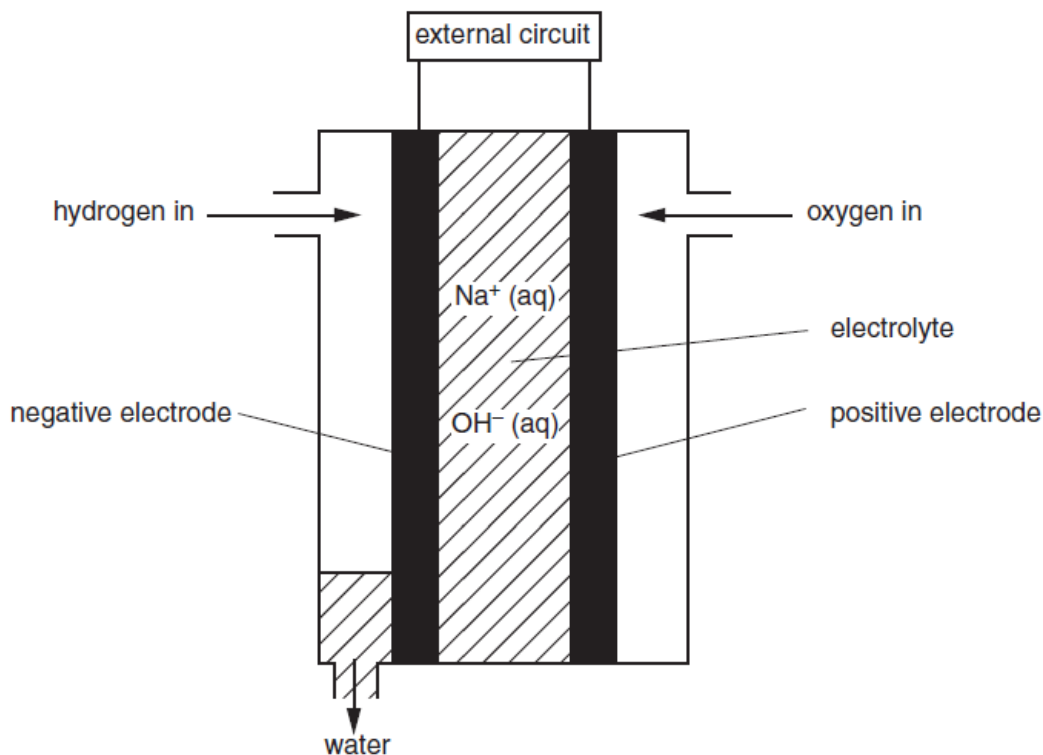

At the positive electrode, oxygen reacts with water as shown.

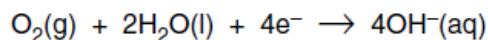

At the negative electrode, hydrogen reacts with hydroxide ions as shown.

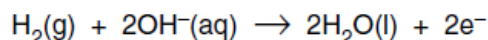

The overall reaction in the fuel cell is the reaction between hydrogen and oxygen to make water.

- Give **one** source for hydrogen and **one** source for oxygen for use in a fuel cell. [2]
- What is the name of the electrolyte used in the fuel cell? [1]
- What type of reaction takes place, reduction or oxidation, at the positive electrode? Explain your answer. [1]
- A fuel cell uses 240 dm^3 of hydrogen. Calculate the volume of oxygen needed, and the mass of water formed. All gas volumes measured at room temperature and pressure. [3]
- Describe some advantages and disadvantages of using a fuel cell to generate electricity. [3]

s/03/qp2

B6 Sodium chloride is used in making many important chemicals including chlorine and hydrogen.

(a) Write the electrode reactions for the electrolysis of **molten** sodium chloride.

Which electrode reaction is an oxidation? Explain your answer. [3]

(b) Explain why the electrolysis of **aqueous** sodium chloride using inert electrodes gives hydrogen. [1]

(c) Explain the three stages in the purification of water supplies. [3]

(d) Hydrogen is used to manufacture ammonia, NH_3 . Calculate the volume of hydrogen needed to react completely with 240 dm^3 of nitrogen, all gas volumes measured at room temperature and pressure. [3]

s/02/qp2
