

6 WORK and ENERGY

Objectives

After studying this chapter you should

- be able to calculate work done by a force;
- be able to calculate kinetic energy;
- be able to calculate power;
- be able to use these quantities in solving problems;
- be able to model problems involving elastic strings and springs;
- know when mechanical energy is conserved.

6.0 Introduction

When you walk, run or cycle up a hill or go upstairs you know that it takes more effort than on the level. You may take part in gymnastics or skiing, you may play squash or go down the water chute at the local Leisure Centre, or you may go on rides like the log flume or the Corkscrew at the Amusement Park. All these activities involve the ideas of **work**, **energy** and **power** developed in this chapter.

6.1 Work and kinetic energy

Example

To move a car of mass 1000 kg along a level road you need to apply a force of about 200 N in the direction of motion to overcome the resistance and get going. If this resistance is 100 N and you push it 20 m, what is the speed of the car?

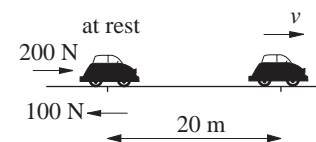

Solution

The net force on the car is $(200 - 100)\text{N} = 100\text{N}$, so if a is the constant acceleration, Newton's Second Law gives

$$100 = 1000a \quad (1)$$

giving

$$a = \frac{100}{1000} = \frac{1}{10} \text{ ms}^{-2}$$

Since the car is initially at rest, if v is its speed after being pushed 20 m

$$v^2 = 0 + 2a \times 20 = 40a = 4$$

or

$$v = 2 \text{ ms}^{-1}.$$

(The result $v^2 = u^2 + 2as$ for constant acceleration was introduced in Chapter 2.)

Consider next the general case of a car of mass m kg. If P is the force given to the car by the person pushing it in the direction of motion, and R the resistance then the equation of motion replacing (1) is

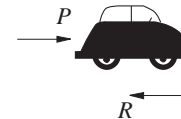

$$P - R = ma$$

so that

$$a = \frac{(P - R)}{m}. \quad (2)$$

When the car has moved a distance x metres from rest its speed v is given by

$$\begin{aligned}
 v^2 &= 2ax \\
 &= 2 \frac{(P - R)}{m} x, \text{ using equation (2),}
 \end{aligned}$$

or rearranging

$$(P - R)x = \frac{1}{2}mv^2. \quad (3)$$

The right hand side of equation (3) depends upon the mass and the final speed of the car. It represents the energy of the car due to its motion and is called the **kinetic energy**.

$ \begin{aligned} \text{Kinetic energy} &= \frac{1}{2} \times (\text{mass}) \times (\text{speed})^2 \\ &= \frac{1}{2}mv^2 \end{aligned} $	(4)
--	-----

The car gains energy as it speeds up. Where has this energy come from? It comes from you pushing the car. To move the car you do work. Some of this work overcomes the resistance and the rest makes the car accelerate. Equation (3) expresses these physical facts mathematically.

Px is called the **work done** by the force P . This is the work you do in pushing the car.

$$\begin{aligned} &\text{Work done by a constant force} \\ &= (\text{Force}) \times (\text{distance moved in the direction of the force}) \end{aligned}$$

The term $-Rx$ in equation (3) is the work done by the resistance. The negative sign occurs since the direction of the force is opposite to the direction of motion.

If the work done by a force is **negative**, work is said to be done **against** the force.

The left hand side of equation (3) is the work done by the resultant force in the direction of motion and is equal to

$$(\text{work done by the force } P) - (\text{work done against the force } R)$$

It is this positive work done which produces the kinetic energy.

This concept of work is a special case of what is meant by the term 'work' in everyday language. To do work in mechanics an object has to move through some distance. The athlete moving the weights vertically upwards does work against the force of gravity. (Gravity is acting downwards, the weights are being moved upwards).

To measure both kinetic energy and the work done by a force we need some units and from equation (3) the units of both these quantities will be the same.

The unit of work is the joule (J), so that 1 J is the work done in moving a force of 1 N through 1 m. Thus

$$1\text{J} = 1\text{Nm}.$$

For the weights of mass 100 kg being lifted 2 m the work done against gravity is

$$100 \times g \times 2 = 2000\text{J}$$

taking $g = 10\text{ms}^{-2}$.

Since the left hand side of equation (3) represents work done and the right hand side kinetic energy, equation (3) is called the **work-energy equation**.

The jumping flea

The flea *Spilopsyllus* weighs about 0.4 mg and leaves the ground, when it jumps, at about 1ms^{-1} . What is its kinetic energy?

In this example the unit of mass needs to be changed to kg.
Now

$$0.4 \text{ mg} = 0.4 \times 10^{-6} \text{ kg},$$

and

$$\begin{aligned} \text{kinetic energy} &= \frac{1}{2} (0.4 \times 10^{-6}) \times (1)^2 \\ &= 0.2 \times 10^{-6} \\ &= 2 \times 10^{-7} \text{ J}. \end{aligned}$$

How is this energy used? Can you say anything about how high the flea jumps?

Why does the earthworm move more slowly than the centipede?

Kinetic energy changes are involved here too. When an earthworm, which has no legs, crawls each segment moves in steps coming to a halt between each step. The whole body is continually being given kinetic energy by the muscles doing work and this energy is quickly dissipated at every stage. For this reason the worm only crawls at about 0.5 cm s^{-1} . On the other hand, a fast species of centipede only 2.2 cm long can run on its legs at 0.45 m s^{-1} . Although at each step the kinetic energy supplied to its legs fluctuates their mass is small compared to the total mass of the centipede and so the main part of the body, which keeps moving, moves at an almost constant speed and so has almost constant kinetic energy, enabling the centipede to move quickly.

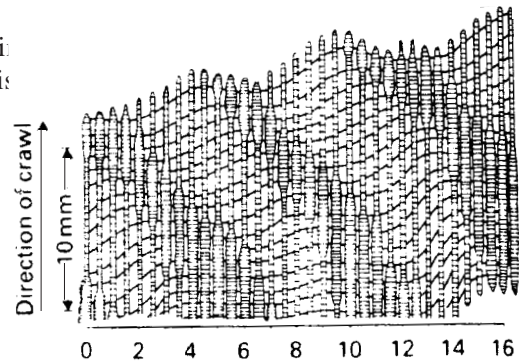

Activity 1 Gravel beds

These are often to be found at the side of some holiday routes and on bendy stretches of road in, for example, the Peak District National Park. Their purpose is to bring a vehicle to a halt safely in the event of brake failure or cornering too fast. The car enters the bed at some speed and so possesses some kinetic energy. It is brought to rest without braking by the friction of the bed. As it slows down it loses energy.

What happens to this energy?

Suppose a car of mass 1 tonne enters the bed at 80 kph and stops after 30 m. Find how much kinetic energy is lost and calculate the average resistance force produced by the gravel.

As a simplified model suppose that a car of mass m kg enters the bed with speed v ms^{-1} and comes to rest after x metres. Suppose that the bed is horizontal and that the resistance force, R , is constant.

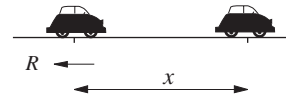

Find the deceleration in terms of R and m and hence derive the work-energy equation $Rx = \frac{1}{2}mv^2$.

Example Green to amber

A car of mass 1300 kg is travelling along a straight level road at 10 ms^{-1} when the traffic lights change from green to amber. The driver applies the brakes 23 metres from the lights and just manages to stop on the line.

Calculate

- the kinetic energy of the car before braking
- the work done in bringing the car to rest
- the force due to the brakes, friction, etc. against which work is done.

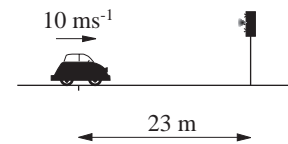

Solution

- (a) The kinetic energy of the car before braking

$$\begin{aligned}
 &= \frac{1}{2} \times 1300 \times (10)^2 \\
 &= 65\,000 \text{ J.}
 \end{aligned}$$

- (b) Using equation (3),
 work done in bringing car to rest
 = kinetic energy lost
 = 65 000 J.

- (c) Since work = (force) \times (distance)

$$\text{force} = \frac{\text{work}}{\text{distance}} = \frac{65000}{23} = 2826 \text{ N.}$$

Part (b) of this example illustrates how the work-energy equation can be used to calculate the work done without knowing the forces involved explicitly.

Returning to the model of the gravel bed and also the earlier example of pushing the car, two other forces act on the car

- its weight mg ,
- the normal contact force.

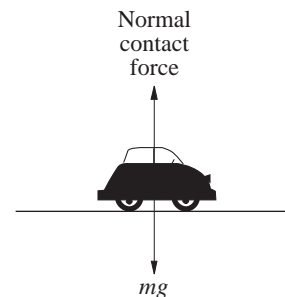

The distance the car moves in the direction of either of these forces is zero and so these forces do no work.

In general, if the direction of motion is perpendicular to the force, no work is done by the force.

The idea of work can be explored a little further.

Car on icy slope

The car of mass 1300 kg now slides 100 m down an icy slope, the slope being inclined at 30° to the horizontal. If the frictional forces on the slope and air resistance are ignored the forces acting on the car are

- (i) its weight $1300g$ N
- (ii) the normal contact force.

The distance the car moves in the direction of the normal contact force is zero and so this force does no work. The only force which does work is the weight. The distance moved in the direction of the weight is

$$100 \times \sin 30^\circ = 50 \text{ m}$$

and so

$$\begin{aligned}
 \text{work done by gravity} &= 1300 \times g \times 50 \\
 &= 1300 \times 10 \times 50 \\
 &= 650\,000 \text{ J.}
 \end{aligned}$$

In this calculation the distance is found in the direction of the force. Alternatively the weight can be replaced by its components

$$1300g \sin 30^\circ \text{ down the slope}$$

$$1300g \cos 30^\circ \text{ perpendicular to the slope.}$$

The component perpendicular to the slope does no work since it is perpendicular to the motion. The only force which does work is the component down the plane and so

$$\begin{aligned}
 \text{the work done} &= (1300 \times g \times \sin 30^\circ) \times (\text{distance down the plane}) \\
 &= 1300 \times g \times \sin 30^\circ \times 100 \\
 &= 650\,000 \text{ J as before.}
 \end{aligned}$$

In summary,

Work done by a force = (component of force in the direction of motion) \times (distance moved).

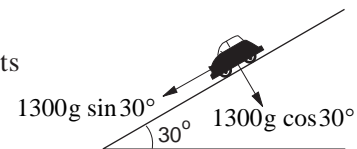
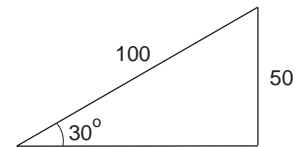
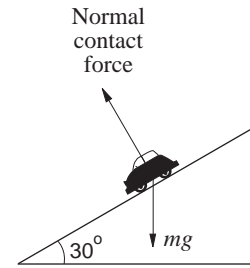

Activity 2 Pulling a sledge

A girl is pulling a sledge through the snow.

What forces act on the sledge?

Which of these forces does the work?

What happens if the sledge is on a slope?

Exercise 6A

(Take $g = 10 \text{ ms}^{-2}$)

- Find the kinetic energy of the following:
 - a runner of mass 50 kg running at 6 ms^{-1}
 - a hovercraft of mass 10^5 kg travelling at 25 ms^{-1}
 - an electron of mass $9 \times 10^{-28} \text{ g}$, speed $2 \times 10^8 \text{ ms}^{-1}$
 - a car of mass 1300 kg travelling at 60 kph.

2. A boy of mass 20 kg rides a bicycle of mass 15 kg along a road at a speed of 5 ms^{-1} . He applies his brakes and halves his speed; calculate the reduction in the kinetic energy.

3. A bullet of mass 0.02 kg travelling with speed 100 ms^{-1} comes to rest when it has gone 0.4 m into sand. Find the resisting force exerted by the sand.

4. A boy of mass 40 kg slides down a chute inclined at 30° to the horizontal. If the chute is smooth and the boy starts from rest, with what velocity does he pass a point 5 m from the starting point?

5. A girl of mass 40 kg slides down the water chute 4 m long at the local leisure centre. If the resultant force down the chute is 200 N with what speed does she leave the chute if she starts from rest?

6. If two men push a car of mass 1000 kg, one at each rear corner, and each exerts a force of 120 N at an angle of 20° to the direction of motion, calculate the work done by the two men in pushing the car 20 m. Assuming that the resistance is 100 N, calculate the speed of the car if it starts from rest.

- A car of mass 1200 kg travelling at 15 ms^{-1} comes to rest by braking in a distance of 50 m. If the additional resistance to motion is 100 N calculate the braking force of the car assuming that it is constant.
- A cable car of mass 1200 kg moves 2 km up a slope inclined at 30° to the horizontal at a constant speed. If the resistance to motion is 400 N find the work done by the tension in the cable.

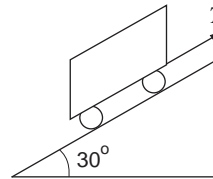

- A man pushes a lawnmower of mass 30 kg with a force of 30 N at an angle of 35° to the horizontal for 5 m. The mower starts from rest and there is a resistance to motion of 10 N. Find the work done by the man and the final speed of the mower.
- A car of mass 1000 kg travelling at 12 ms^{-1} up a slope inclined at 20° to the horizontal stops in a distance of 25 m. Determine the frictional force which must be supplied.
- A 70 kg crate is released from rest on a slope inclined at 30° to the horizontal. Determine its speed after it slides 10 m down the slope if the coefficient of friction between the crate and the slope is 0.3.

6.2 Work done against gravity: gravitational potential energy

When weights of mass 100 kg are lifted 2 m

$$\begin{aligned} \text{work done against gravity} &= 100 \times g \times 2 \text{ J} \\ &= (\text{mass}) \times g \times (\text{vertical height}). \end{aligned}$$

Generalising this to the case of weights of mass m kg raised vertically through a distance h m the work done against gravity is $\text{mass} \times g \times \text{vertical height}$.

mgh is the work done **against** gravity.

In the example of the car sliding **down** the icy slope

$$\begin{aligned} \text{work done by gravity} &= 1300 \times g \times 50 \text{ J} \\ &= (\text{mass}) \times g \times (\text{vertical distance through} \\ &\quad \text{which the car moved}) \end{aligned}$$

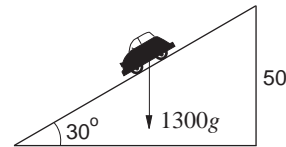

If the car had been moving **up** the slope

$$\begin{aligned} \text{work done by gravity} &= -1300 \times g \times 50 \text{ J} \\ &= -(\text{mass}) \times g \times (\text{vertical distance through} \\ &\quad \text{which the car moved}) \end{aligned}$$

or alternatively,

$$\begin{aligned} \text{work done against gravity} &= 1300 \times g \times 50 \text{ J} \\ &= (\text{mass}) \times g \times (\text{vertical distance} \\ &\quad \text{through which the car moved}) \end{aligned}$$

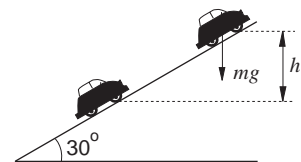

For a car of mass m the work done against gravity is still mgh . Since this result does not involve the angle of the slope, θ , it is the same for **any** slope.

If you go upstairs is the work done against gravity still your weight times the vertical height?

In fact this result is true for **any** path joining two points A and B. The work against gravity is always

$$mg \times (\text{vertical height from A to B}),$$

and is **independent** of the path joining A to B.

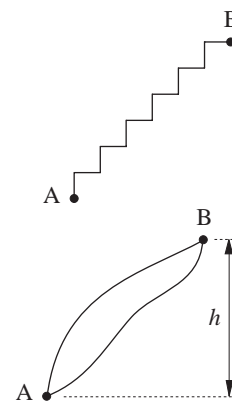

In **raising** a body up through a height h it has **gained** energy due to its change in position. Energy due to position is called **potential energy**. This particular form of potential energy is called **gravitational potential energy**.

Gain in gravitational potential energy in moving an object from A to B = work done against gravity in moving from A to B

$$= (\text{mass}) \times g \times (\text{vertical height from A to B}).$$

6.3 Work-energy equation. Conservation of energy

For the earlier example of pushing a car the work-energy equation is

$$Fx = \frac{1}{2}mv^2, \quad (5)$$

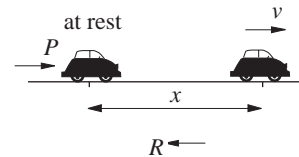

where $F = P - R$ is the resultant force in the direction of motion. How is this equation modified if the car moves with constant acceleration, a , from a speed u to speed v over a distance of x metres? If F is the resultant force in the positive x -direction the equation of motion is still

$$F = ma$$

giving

$$a = \frac{F}{m}. \quad (6)$$

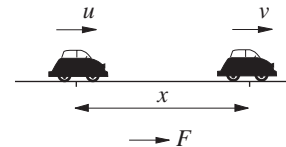

From Chapter 2, you know that

$$\begin{aligned} v^2 &= u^2 + 2ax \\ &= u^2 + 2\frac{F}{m}x, \quad \text{using (6)} \end{aligned}$$

or

$$mv^2 = mu^2 + 2Fx$$

Rearranging

$$Fx = \frac{1}{2}mv^2 - \frac{1}{2}mu^2 \quad (7)$$

so that

work done by the force F = final kinetic energy –
initial kinetic energy

work done by the force F = change in kinetic energy
produced by the force.

Equation (7) is the work-energy equation for this situation. It
reduces to equation (5) in the special case when $u = 0$.

For a body falling under gravity from A to B, $F = mg$ and using
equation (7),

$$mgh = \frac{1}{2}mv^2 - \frac{1}{2}mu^2 \quad (8)$$

or work done by gravity = change in kinetic energy
produced by gravity.

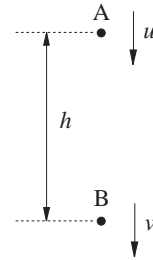

Activity 3 Introducing conservation of energy

In equation (8) the ball falls a height h .

Suppose now you choose a horizontal level so that A is at a
height h_1 and B is at a height h_2 above the chosen level.

Write down the work done by the force of gravity as the body
falls from A to B in terms of h_1 and h_2 .

Show that the sum of the kinetic energy and potential energy is
the same at A and at B.

Repeat the calculation with a different horizontal level. What do
you find?

Defining

mechanical energy = kinetic energy + potential energy

Activity 3 shows that mechanical energy has the same value at A
and B, in other words, mechanical **energy is conserved**.

Activity 3 also shows that it does not matter which horizontal or
zero you work from in calculating the potential energy since it is
only **changes** in potential energy that are involved. Once you
have chosen the zero level, which can often be done to simplify
calculations, you must use the same level throughout.

When you release a ball from rest, as the height of the ball decreases its potential energy decreases but the speed of the ball increases and so its kinetic energy increases. If air resistance is neglected the only force acting is gravity and from equation (8) putting $u = 0$

$$mgh = \frac{1}{2}mv^2,$$

So the decrease in potential energy = increase in kinetic energy.
 Since m cancels

$$v^2 = 2gh$$

or

$$v = \sqrt{2gh}.$$

So, the speed v can be found from considering energy; the speed v is independent of the mass of the ball; it only depends upon the height from which the ball is released.

Does this result hold for a particle sliding down a smooth inclined plane from a vertical height h ?

As the ball falls its potential energy changes to kinetic energy in such a way that at any time the total energy remains the same. If the ball is lifted a vertical height h and then released from rest, the work done against gravity in lifting the ball can be recovered as kinetic energy and for this reason the force of gravity is called a **conservative force**. A property of such forces is that the work done is independent of the path. On the other hand, forces such as friction and air resistance are not conservative because the work done against them is dissipated and so cannot be recovered. It appears mainly in the form of heat.

Activity 4 Dropping a ball from rest

You will need a bouncy ball, 2 metre rulers, and scales to weigh the ball for this activity.

Drop a ball from 2 m above a hard floor surface, releasing the ball from rest.

What happens to the ball? Explain the motion in terms of energy.

Calculate the speed of the ball when it hits the floor.

Why does the ball not bounce back to the same height?

Measure how high the ball bounces.

Calculate the loss of mechanical energy.

If there is a loss of mechanical energy, where does this energy go?

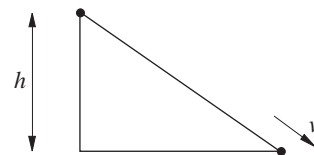
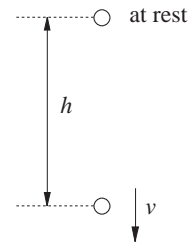

Example

Two masses 4 kg and 6 kg are attached to the ends of an inextensible string over a pulley. The weights of the string and pulley are much smaller than the two masses attached and so are neglected. The pulley is also assumed to be smooth so that the tension T is the same on both sides of the pulley. The masses are held at the same level and the system is released from rest. What is the speed of the 6 kg mass when it has fallen 2 metres?

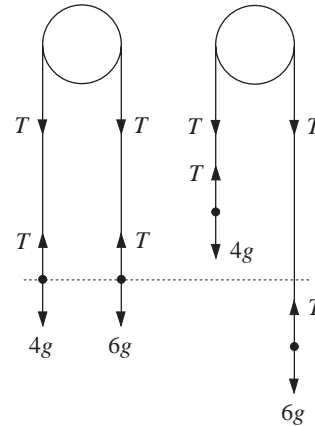

Solution

Equation (7) can be applied to the two masses separately. For the 4 kg mass the resultant force in the direction of motion is $T - 4g$ and so when this mass has risen 2 metres,

$$(T - 4g) \times \text{distance} = \text{change in kinetic energy}$$

or

$$(T - 4g) \times 2 = \frac{1}{2} \times 4v^2 = 2v^2, \quad (9)$$

where $v \text{ ms}^{-1}$ is its speed.

For the 6 kg mass the resultant force in the direction of motion is $6g - T$, so that

$$(6g - T) \times 2 = \frac{1}{2} \times 6v^2 = 3v^2, \quad (10)$$

since the 6 kg mass also has speed $v \text{ ms}^{-1}$.

Adding equations (9) and (10) gives

$$12g - 8g = 5v^2$$

or

$$4g = 5v^2$$

giving

$$v^2 = \frac{4}{5}g$$

or

$$v \approx 2.8 \text{ ms}^{-1}.$$

Is it necessary to consider the work done by the tension?

Is mechanical energy conserved for this system?

If so how can the solution be modified?

How would the situation be affected if the pulley was not smooth?

What difference would it make if the rope had a significant weight?

Both this and the falling ball problem illustrate how the 'work-energy' or 'conservation of energy' methods can be used to solve the problem, rather than using Newton's Second Law of motion. This is because, in these examples, you are interested in the speed as a function of distance, and energy methods are quicker in this situation.

Activity 5 Kinetic and potential energy

Make a list of other activities which involve changes of kinetic and potential energy.

If friction or air resistance are included in the model, mechanical energy is no longer conserved, but the work-energy equation is still applicable.

To illustrate this consider the case of a body moving down a rough inclined plane. An example is a skier coming down a ski slope at speeds when air resistance can be neglected but friction between the skier and the slope is significant. The forces acting on the skier are indicated on the diagram. If the skier starts from rest at the top of the slope and has speed v at the bottom

$$\text{the increase in kinetic energy} = \frac{1}{2}mv^2,$$

$$\text{distance down the slope} = L = \frac{h}{\sin \theta}.$$

Resolving the forces perpendicular to the plane gives

$$N = mg \cos \theta$$

and then the law of friction gives

$$F = \mu N = \mu mg \cos \theta.$$

The work done by the weight and friction

$$\begin{aligned} &= (mg \sin \theta) \times L - (\mu mg \cos \theta) \times L \\ &= mg \sin \theta \left(\frac{h}{\sin \theta} \right) - \mu mg \cos \theta \left(\frac{h}{\sin \theta} \right) \\ &= mgh - \mu mgh \cot \theta. \end{aligned}$$

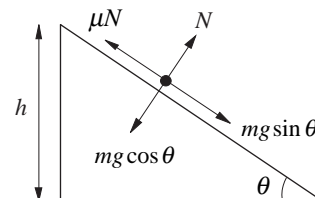
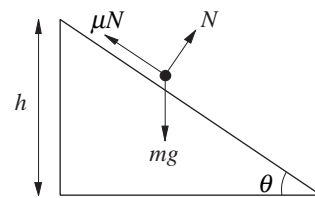
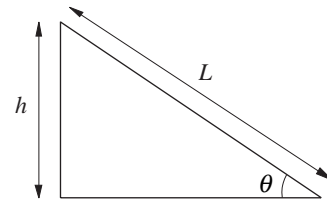

By the work-energy equation

$$\frac{1}{2}mv^2 = mgh - \mu mgh \cot \theta$$

or

$$v^2 = 2gh(1 - \mu \cot \theta) .$$

Note that $v^2 > 0$ means $1 > \mu \cot \theta$ or $\tan \theta > \mu$, so the angle of the inclination of the plane, θ , must be sufficiently large for the motion to occur.

If the surface is smooth then $\mu = 0$ and $v^2 = 2gh$ as before.

However, for a rough surface $\mu \neq 0$, so that the speed at the bottom of the slope is less than $\sqrt{2gh}$ which is intuitively obvious.

Exercises 6B

1. A man of mass 60 kg climbs a mountain of height 2000 m. What work does he do against gravity?
2. A crane lifts material of mass 500 kg a height 10 m. What is the work done against gravity by the crane?
3. An athlete of mass 80 kg starts from rest and sprints until his speed is 10 ms^{-1} . He then takes off for a high jump and clears the bar with his centre of mass (the point where his weight is assumed to be concentrated) at a height of 2.2 m. How much work has he done up to the moment when he clears the bar?
4. A stone of mass 1 kg is dropped from the top of a building 80 m high .
 - (a) Find the total mechanical energy of the stone before it is released and when it has fallen a distance x metres and its speed is $v \text{ ms}^{-1}$.
 - (b) Assuming that energy is conserved show that the speed of the stone v and the distance x are related by the equation $v^2 = 20x$.
 - (c) Find the speed of the stone when it is half-way to the ground and when it hits the ground.
5. A ball of mass 100 g is thrown vertically upwards from a point 2 m above ground level with a speed of 14 ms^{-1} .
 - (a) With an origin at ground level, find the total mechanical energy of the ball when it is travelling at speed $v \text{ ms}^{-1}$ at a height h m.
 - (b) Assuming that mechanical energy is conserved show that $v^2 + 20h = 236$.
 - (c) Calculate the greatest height reached by the ball.
 - (d) Calculate the speed with which the ball hits the ground.

6.4 Power

In some situations it is not only the work done which is important but the time taken to do that work. If you are exercising, the rate at which you exercise may be important. When manufacturers state the time taken for a car to reach a certain speed they are saying something about the **rate** at which work can be done by the engine.

The rate at which work is done is called **power**. If it takes 75 s to move a car a distance of 20 m applying a force of 200 N then the average rate of working or the average power is

$$\frac{\text{work done}}{\text{time taken}} = \frac{200 \times 20}{75} = 53.3 \text{ N ms}^{-1} = 53.3 \text{ Js}^{-1}.$$

The unit of power is the watt (W) named after the Scottish inventor *James Watt*, famous amongst other things for harnessing the power of steam. 1 watt is defined as 1 joule per second

$$1 \text{ W} = 1 \text{ J s}^{-1}.$$

The power needed to raise 1 kg vertically 10 cm in 1 s is

$$(\text{weight}) \times (\text{distance}) = (1 \times g) \times (10 \times 10^{-2}) \approx 1 \text{ W}$$

(remembering distances are measured in metres) and so the watt is a fairly small unit. For this reason power is frequently measured in kilowatts (kW). Engineers often quote power in horsepower (h.p.) where

$$1 \text{ h.p.} = 746 \text{ W}.$$

This unit, which is used for cars and lorries, was first introduced by *James Watt* (1736 - 1819). It is based on the rate at which large horses, once used by brewers, worked. It is about ten percent greater than the rate at which most horses can work. The French horsepower is slightly less than the British horsepower.

Activity 6 Modelling the Log Flume at a Theme Park

At the beginning of the Log Flume ride the boat and passengers are carried up the slope by a conveyor belt. In this activity you estimate the power required to get one full boat up the ramp.

Here is the data taken on a recent visit.

Time taken to raise one boat up the slope = 20 s.

(Maximum of 6 persons per boat)

Angle of elevation about 30° .

Height about 12 m.

Mass of boat 150 kg.

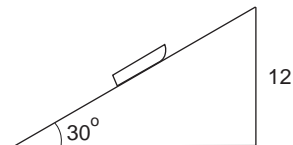

Taking the average mass of each passenger as 60 kg, calculate the energy required to raise 1 boat and 6 passengers.

Hence calculate the power required to raise the full boat.

In some cases when the power is specified, the speed is required at a given time. What is the relationship between power and speed? When pushing the car, in the example at the start of Section 6.4,

the average power = $200 \times \frac{20}{75} = (\text{force}) \times (\text{average speed})$.

If a constant force F moves a body in the direction of the force and at a certain time the body is moving with speed v , then what is the power at that time?

Suppose that at time t the distance moved by the body is x metres, then at this time

$$W = \text{work done} = F \times x.$$

Now remembering that power P is rate of doing work

$$P = \frac{d}{dt}(Fx) = F \frac{dx}{dt}, \text{ since } F \text{ is constant and } x \text{ varies with } t,$$
$$= Fv,$$

so $P = Fv$ (11)

or Power = Force \times Speed.

Example

A car moves along a horizontal road against a resistance of 400 N. What is the greatest speed (in kph) the car can reach if the engine has a maximum power of 16 kW?

Solution

The car reaches its maximum speed when the engine is at maximum power 16 000 W. The power needed for the car to move against the resistance at speed $v \text{ ms}^{-1}$ is $400v$, using equation (11). The speed v is a maximum when

$$16000 = 400v$$

giving

$$\begin{aligned} \text{maximum speed} = v &= 40 \text{ ms}^{-1} \\ &= \frac{40}{1000} \times 60 \times 60 \text{ kph} \\ &= 144 \text{ kph.} \end{aligned}$$

Activity 7 How fast does the lorry go up the hill?

The main frictional resistance F on a lorry is due to the air and depends on the velocity v . For a lorry which has a maximum power of 250 kW, a reasonable assumption is $F = 6v^2$.

What is the speed of the lorry going along a level road when it uses half of its power?

If the lorry uses all of its power to go up a hill with slope 1 in 50,

how do the maximum speeds compare when the lorry is laden to a total mass of 38 tonnes and 44 tonnes?

You may find it easiest to solve the equations you obtain for the maximum speeds graphically.

Pumping water

Often on roadworks pumps are needed to pump water out of the ground. A pump is required to raise 0.1 m^3 of water a second vertically through 12 m and discharge it with velocity 8 ms^{-1} . What is the minimum power rating of pump required?

Here the work done is in two parts: the water is raised through 12 m and is also given some kinetic energy. Since 1 m^3 of water weighs 1000 kg, the mass of water raised is 100 kg.

The work done in 1 second against this weight of water is

$$\begin{aligned} & (\text{mass raised}) \times g \times (\text{height raised}) \\ & = 100 \times 10 \times 12 = 12000 \text{ J, taking } g = 10 \text{ ms}^{-2}. \end{aligned}$$

The kinetic energy given to the water in 1 second is

$$\begin{aligned} & = \frac{1}{2} \times (\text{mass raised}) \times (\text{speed})^2 \\ & = \frac{1}{2} \times 100 \times (8)^2 = 3200 \text{ J.} \end{aligned}$$

Hence the total work done in 1 second is

$$12000 + 3200 = 15200 \text{ J.}$$

The power required is 15.2 kW.

If the pump is 100% **efficient** this is the rate at which the pump is working to raise the water. In practice some power is lost and pumps work at less than 100% efficiency. Here

$$\text{efficiency} = \frac{\text{power output}}{\text{power input}} \times 100\%$$

If the pump is only 60% efficient, to raise this water it would need to be working at a rate of

$$\begin{aligned} 15200 \times \frac{100}{60} & = 25333.3 \text{ J s}^{-1} \\ & = 25.3 \text{ kW.} \end{aligned}$$

Since some power is lost, 15.2 kW is the minimum power rating of the pump.

Exercise 6C

1. A crane raises a 5000 kg steel girder at 0.4 ms^{-1} . Assuming that work is not lost in driving the crane, at what rate is the crane working?
2. A train of mass $5 \times 10^5 \text{ kg}$ is travelling at 30 ms^{-1} up a slope of 1 in 100. The frictional resistance is 50 N per 10^3 kg . Find the rate at which the engine is working.
3. A car of mass 1000 kg moves along a horizontal road against a resistance of 400 N and has maximum power of 16 kW. It pulls a trailer of mass 600 kg which is resisted by a force of 300 N. When the speed is 24 kph and the engine is working at maximum power find the acceleration of the car and trailer and the pull in the tow rope.
4. A lorry of mass 5000 kg with an engine capable of developing 24 kW, has a maximum speed of 80 kph on a level road. Calculate the total resistance in newtons at this speed.
Assuming the resistances to be proportional to the square of the speed, calculate in kilowatts the rate of working of the engine when the truck is climbing a gradient of 1 in 200 at 60 kph and has, at that instant, an acceleration of 0.025 ms^{-2} .
5. Two tugs are pulling a tanker in a harbour at a constant speed of 1.5 knots, as shown. Each cable makes an angle of 12° with the direction of motion of the ship and the tension in the cable is 75 kN. Calculate the rate of working of the two tugs. (1 knot = 1.852 kph)

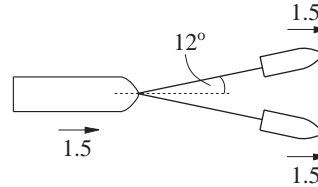

6. Find the power of a firepump which raises water a distance of 4 m and delivers 0.12 m^3 a minute at a speed of 10 ms^{-1} .
7. A pump is required to raise water from a storage tank 4 metres below ground and discharge it at ground level at 8 ms^{-1} through a pipe of cross sectional area 0.12 m^2 . Find the power of the pump if it is
(a) 100% efficient (b) 75% efficient.

6.5 Elasticity – Hooke's Law

So far strings have been assumed to be inextensible. Whilst for some strings this assumption is reasonable, there are other materials whose lengths change when a force is applied.

Activity 8 How do materials behave under loading?

You will need wire, coiled springs, shirring elastic, masses and a support stand for this activity.

By hanging different masses from the ends of the given materials, investigate the relation between the mass m , and the change in the length x , from the original length.

Display your results graphically.

Test your specimens to see if they return to their original length when the masses are removed.

Keep your data for use in Activity 9.

All your specimens are materials which can behave elastically. When you pull the material its length increases but it returns to its original length, sometimes called its **natural length**, when released.

For some of your specimens you may have obtained straight lines such as either (a) or (b), whereas for other specimens a curve like (c) may have occurred. Now

$$\text{Extension} = \text{stretched length} - \text{natural length.}$$

If you add too many masses to the wire it either breaks or keeps extending to the floor. This behaviour occurs when you pass the **elastic limit** and in the case when the wire keeps extending the wire is behaving **plastically**.

When you apply a force to the end of an elastic string and stretch it the string exerts an inward pull or **tension** T which is equal to the applied force. In case (a) if l is the natural length, L the final length and m is the total mass attached then you will have seen from Activity 8 that the extension $x (= L - l)$ and m are linearly related by

$$m = qx, \quad (12)$$

where q is the gradient of the straight line. Although the strings and springs used in Activity 8 have masses, they are very much less than those which are added and so can be neglected.

When a mass attached to the end of a specimen is in equilibrium two forces act, the tension T upwards and the weight mg downwards. Since the mass is at rest

$$T - mg = 0$$

or

$$T = mg. \quad (13)$$

Eliminating m between equations (12) and (13) gives

$$T = (qg)x \quad (14)$$

so that T is directly proportional to x . Putting $k = qg$ equation (14) becomes

$$T = kx. \quad (15)$$

This is known as **Hooke's Law**. The constant of proportionality k is called the **stiffness**. This is an experimental result which holds for some materials over a limited range, in some cases only for small extensions. Other materials behave elastically for large extensions but the relation is not linear, e.g. curve (c) above.

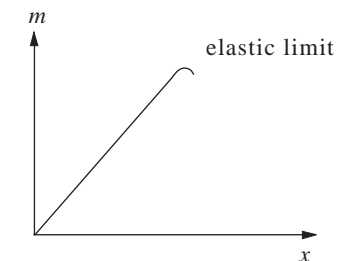
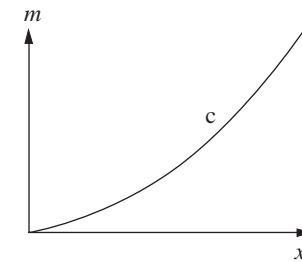
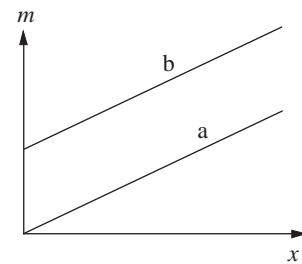

Putting $k = \frac{\lambda}{l}$, an alternative form of equation (15) is

$$T = \frac{\lambda}{l} x. \quad (16)$$

Whereas k depends inversely upon l , the constant λ , called the **modulus of elasticity**, does not depend upon the length but only on the material. Different materials have different values of λ . When $x = l$, $\lambda = T$ and so λ is equal to the tension in the string whose length has been doubled. λ has the units of force and so is measured in newtons. The stiffness $k = \frac{\lambda}{l}$ is measured in Nm^{-1} .

material	modulus of elasticity
aluminium	5.5×10^4
copper	8.8×10^4
brass	7.3×10^4
mild steel	1.6×10^5

Some values of the modulus of elasticity for wires of diameter 1 mm made from different materials

Activity 9 How stiff are the materials?

From your data in Activity 8, where appropriate, determine the values of k and λ for the specimens.

Example

An elastic string of natural length 60 cm has one end fixed and a 0.6 kg mass attached to the other end. The system hangs vertically in equilibrium. Find the stiffness of the string if the total length of the string in the equilibrium position is 72 cm.

Solution

The forces acting on the mass are the tension T upwards and its weight mg downwards. Since the mass is at rest

$$T - 0.6g = 0$$

or

$$T = 0.6g = 6 \text{ N.}$$

The extension of the string = 12 cm = 0.12 m and so using Hooke's Law

$$T = k(0.12).$$

Equating the expressions for T

$$0.12k = 6$$

or

$$k = \frac{6}{0.12} = 50 \text{ Nm}^{-1}.$$



An elastic string is in tension when it is extended. When it is slack its tension is zero. An open-coiled elastic spring can either be extended or compressed. When it is extended there is a tension in the spring, when it is compressed smaller than its natural length there is an outward push, or **thrust**. In both cases these forces tend to restore the spring to its natural length.

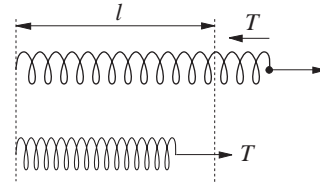

Example

A set of kitchen scales consists of a scale pan supported on a spring as shown. For a particular make of scales the stiffness is 2000 Nm^{-1} . Find the compression of the spring when measuring 1.5 kg of flour.

Solution

Modelling the flour as a particle, the forces on the flour are its weight $1.5g$ downwards and the thrust T exerted by the spring upwards. Since the system is in equilibrium

$$T - 1.5g = 0$$

or

$$T = 1.5g = 15 \text{ N}.$$

Applying Hooke's Law, since the stiffness k is 2000 Nm^{-1} the compression of the spring is given by

$$\text{compression} = \frac{T}{k} = \frac{15}{2000} = 0.0075 \text{ m} = 0.75 \text{ cm}.$$

Elastic materials do not only occur in the form of strings or springs.

Identify as many situations as possible where elastic materials arise.

Elastic materials also occur in animals and humans. The elastic properties of tendons reduce the work muscles do in hopping or running. In the necks of hooved mammals there is a highly extensible ligament (ligamentum nuchae) which helps support the weight of the head and serves as a tension spring. Its elastic properties are similar to the load against extension curve (c) at the beginning of this section, i.e. they are not linearly related.

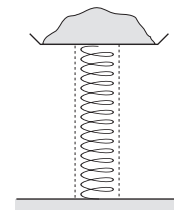

Exercise 6D

1. An elastic spring is hanging vertically with a mass of 0.25 kg on one end. If the extension of the spring is 40 cm when the system is in equilibrium, find the stiffness of the spring.
2. An elastic spring of stiffness 0.75 Nm^{-1} has one end fixed and a 3 gram mass attached to the other end. The system hangs vertically in equilibrium when the spring has length 49 cm. What is the natural length of the spring?
3. A mass of 0.5 kg is attached to the end of an elastic spring hanging vertically with the other end fixed. If the extension of the spring is 8 cm when the system is in equilibrium:
 - (a) What is the stiffness of the spring?
 - (b) What mass would be required to produce an extension of 10 cm?

6.6 Work done in stretching an elastic string

To extend an elastic string you apply a force. As the extension increases, the tension in the string increases according to Hooke's Law, and so the force you apply increases. You do work against this tension. How much work do you do in extending the string a given distance and what happens to this work? Since the tension varies with distance moved it is necessary to know how to calculate the work done by or against a **variable** force.

One way of interpreting the work done by the constant force $F = F_0$ **acting in the x -direction** is to plot the force against the distance x , then

$$\text{work done by the force} = F_0 \times x$$

=shaded area under the straight line.

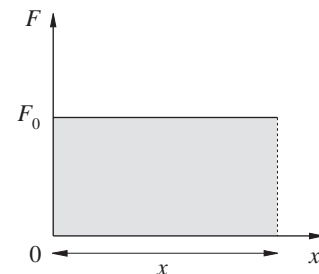

If the force acts in the direction opposite to x then you can replace F_0 by $-F_0$ and the area is **below** the x -axis indicating that the work done is **against** the force.

This approach can be generalised to the variable tension. In this case the tension T acts against the direction of motion and so T is given by $T = -kx$.

The work done by the tension

$$\begin{aligned}
 &= -(\text{area of the shaded triangle}) \\
 &= -\left(\frac{1}{2} \times \text{base} \times \text{perpendicular height}\right) \\
 &= -\left(\frac{1}{2} \times x \times kx\right) \\
 &= -\frac{1}{2}kx^2
 \end{aligned}$$

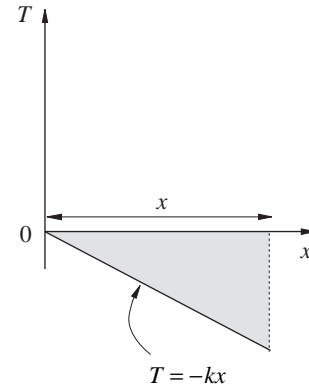

and so

work done **against** the tension $= \frac{1}{2}kx^2$

(17)

This is the amount of work you have to do to stretch the string. This energy is stored in the string. Since it depends upon position, it varies with x ; it is another type of potential energy and is called **elastic potential energy**. If the string is stretched and then released motion occurs and the amount of work done by the

tension as the string returns to its natural length is $\frac{1}{2}kx^2$.

Discuss the motion of a mass attached to the end of a stretched elastic spring either on a horizontal table or suspended vertically.

Elastic potential energy $= \frac{1}{2}kx^2 = \frac{\lambda x^2}{2l}$

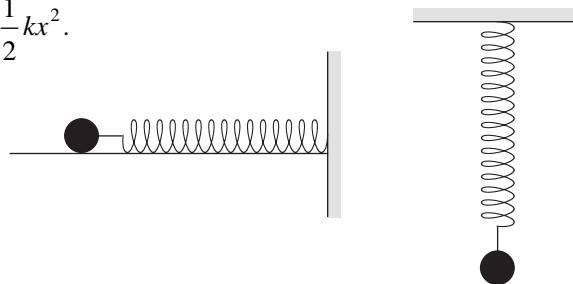

This is also the energy stored in an elastic spring which obeys Hooke's Law when it is compressed a distance x . In both the stretched string and compressed spring this energy is recoverable.

Elastic energy is also stored when you squeeze a rubber ball or when a squash ball hits the wall of the court. When an elastic ball lands on the ground it deforms and so has some elastic energy.

At the point when the ball is instantaneously at rest on the ground (taken to be the zero level of potential energy) all the energy is stored in the ball which then rebounds off the ground at which stage the elastic energy is released and converted into potential energy and kinetic energy.

Elastic energy is stored whenever an elastic material is deformed whatever its shape. For example, when an athlete jumps on a trampoline, the trampoline stores elastic energy which is later released to the athlete.

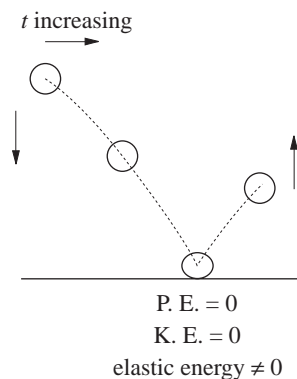

Example

An elastic string of length 1 m is suspended from a fixed point. When a mass of 100 g is attached to the end, its extension is 10 cm. Calculate the energy stored in the string. When an additional 100 g is attached to the end the extension is doubled. How much work is done in producing this extra 10 cm extension?

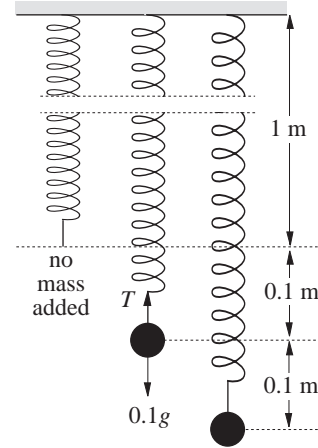

Solution

To calculate the energy you need to know the stiffness of the string. Since the 100 g mass is hanging in equilibrium

$$\text{tension upwards} = \text{weight downwards}$$

$$k(0.1) = (0.1)g$$

giving $k = g$

and elastic potential energy $= \frac{1}{2}g(0.1)^2 = 0.05 \text{ J}$.

When an additional 100 g mass is added the string extends a further 10 cm. The extension of the string is now 20 cm and

$$\text{the elastic potential energy} = \frac{1}{2}g(0.2)^2 = 0.2 \text{ J} .$$

The work done in stretching the extra 10 cm is

$$0.2 - 0.05 = 0.15 \text{ J}$$

which is not the same as the work done in stretching it the first 10 cm.

The result is shown in the diagram opposite.

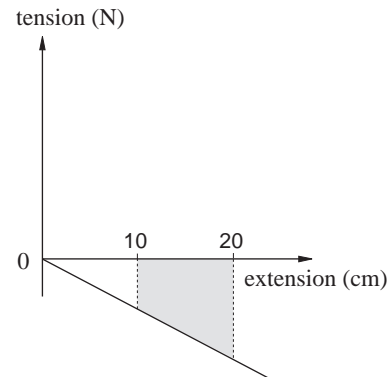

Activity 10 Elastic potential energy

You will need a metre rule, a piece of shirring elastic approximately 1 m in length, Blu-tack and a small mass for this activity.

Attach the mass to one end of the elastic string.

Attach the other end firmly to a table A using Blu-tack.

Extend the string by a known amount x cm ($x = 1, 2, 3, 4, 5$ cm), release the mass and record the distances y cm.

Take at least 6 readings for y for each value of x and average.

Using either a function graph plotter program or graphic calculator find the relationship between x and y .

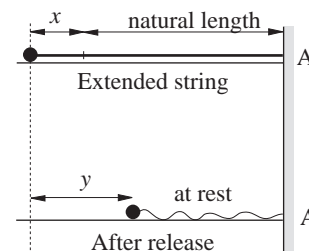

Write down the work-energy equation to model this situation.

Do your results validate the model?

Exercise 6E

- An elastic spring has natural length 1.5 m and stiffness 100 Nm^{-1} . Calculate the work done in extending it
 - from 1.5 m to 1.7 m,
 - from 1.7 m to 1.9 m.
- An elastic string AB of natural length 3 m and stiffness 4 Nm^{-1} has its end A attached to a fixed point. A force of 4N is applied to the end B. Calculate the work done by the force in extending the string.
- In a newton metre the distance between readings differing by 1kg is 0.01 m. If the unstretched length of the spring is 0.1 m, find its stiffness. Calculate the energy stored in the spring when a 3 kg mass is attached.
- A spring whose unstretched length is 0.1 m and stiffness 1000 Nm^{-1} hangs vertically with one end fixed. What extension is produced if a 10 kg mass is suspended at the other end? What additional extension is produced if a further 10 kg mass is added? Calculate the work done against the tension in the spring in producing the additional extension.

6.7 Energy revisited

In Section 6.3, the work-energy equation was formulated in the following form

$$\text{work done by the force} = \text{change in kinetic energy produced by the force} \quad (18)$$

For a stretched string the force doing the work varies with distance.

Does equation (18) still hold when the force $F(x)$ varies with the distance x ? How do you find the work done by a force which does not depend linearly upon x ?

If the curve is not a straight line the work done by the force is given by the area under the graph of $y = F(x)$ from $x = a$ to $x = b$ which is

$$\int_a^b F(x) dx.$$

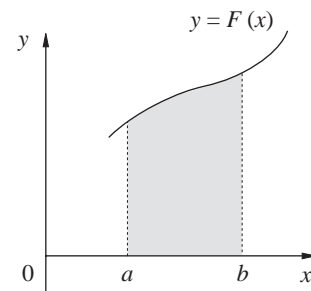

Remember that this integral will be negative if $F(x)$ is negative indicating that the work done is against the force.

Consider the question for any mass m displaced a distance $l + x$ from the level at which the spring is suspended. Here l is the natural length of the spring.

The forces acting on the mass are its weight mg downwards and the tension $T = kx$ in the spring upwards.

The resultant force acting on the mass is $(mg - T)$ downwards.

The work done by this resultant force in extending the spring a distance x is given by

$$\int_0^x (mg - T)dx = \int_0^x (mg - kx)dx$$

$$= mgx - \frac{1}{2}kx^2.$$

Using the work-energy equation (18)

$$mgx - \frac{1}{2}kx^2 = \frac{1}{2}mv^2 - \frac{1}{2}mu^2$$

or

$$\underbrace{\frac{1}{2}mv^2}_{\text{kinetic energy at B}} - \underbrace{mgx}_{\text{gravitational potential energy at B}} + \underbrace{\frac{1}{2}kx^2}_{\text{elastic potential energy at B}} = \frac{1}{2}mu^2 = \text{constant} \quad (19)$$

So $\text{kinetic energy} + \text{gravitational potential energy} + \text{elastic potential energy} = \text{constant} \quad (20)$

Defining the left hand side of equation (20) as the **mechanical energy** you see that

MECHANICAL ENERGY IS CONSERVED.

Example

A 100 g mass is attached to the end B of an elastic string AB with stiffness 16 Nm^{-1} and natural length 0.25 m, the end A being fixed. The mass is pulled down from A until AB is 0.5 m and then released.

Find the velocity of the mass when the string first becomes slack and show that the mass comes to rest when it reaches A.



Solution

Whilst the string is extended it has elastic potential energy. This is zero as soon as the string becomes slack.

Taking the zero level of potential energy to be at the initial position of the mass since the mass is at rest in this position

$$\text{kinetic energy} = 0$$

$$\text{gravitational potential energy} = 0$$

$$\begin{aligned} \text{elastic potential energy} &= \frac{1}{2} k (\text{extension})^2 \\ &= \frac{1}{2} 16(0.25)^2 = 0.5 \text{ J.} \end{aligned}$$

Hence total mechanical energy = 0.5 J

If v is the speed of the mass when the string becomes slack

$$\text{kinetic energy} = \frac{1}{2}(0.1)v^2$$

$$\text{elastic potential energy} = 0$$

$$\text{gravitational potential energy} = (0.1)g(0.25) = 0.25 \text{ J.}$$

So total mechanical energy = $0.05v^2 + 0.25 \text{ J.}$

If the mass comes to rest a distance h m above the initial position then at this point

$$\text{kinetic energy} = 0$$

$$\text{elastic potential energy} = 0$$

$$\text{gravitational potential energy} = (0.1)g h = h.$$

So total mechanical energy = $h \text{ J.}$

Since mechanical energy is conserved

$$0.5 = 0.05v^2 + 0.25 = h$$

so that

$$0.05v^2 = 0.5 - 0.25 = 0.25$$

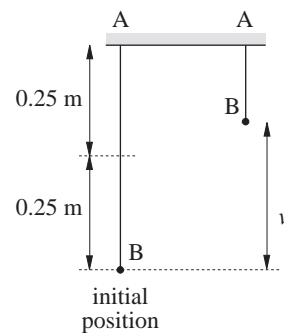
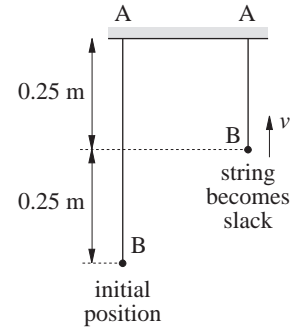

giving

$$v^2 = \frac{0.25}{0.05} = 5$$

or

$$v = 2.2 \text{ ms}^{-1}$$

and

$$h = 0.5 \text{ m} .$$

When the string becomes slack the mass is travelling at 2.2 ms^{-1} .

Since $h = 0.5 \text{ m}$ the mass comes to rest at A.

Example

In a horizontal pinball machine the spring is compressed 5 cm . If the mass of the ball is 20 g and the stiffness of the spring is

800 Nm^{-1} what is the speed of the ball when it leaves the spring assuming that friction can be neglected?

Solution

At B the spring is compressed and

$$\text{elastic potential energy} = \frac{1}{2} \times 800 \times (0.05)^2 = 1 \text{ J}$$

$$\text{kinetic energy of ball} = 0 \text{ J}.$$

So total mechanical energy = 1 J .

At A the spring has returned to its natural length, and

$$\text{elastic potential energy} = 0$$

$$\begin{aligned} \text{kinetic energy of ball} &= \frac{1}{2} \times (0.02) \times v^2 \\ &= 0.01v^2 \text{ J} . \end{aligned}$$

So total mechanical energy = $0.01v^2 \text{ J}$.

Since energy is conserved

$$0.01v^2 = 1$$

giving

$$v^2 = 100$$

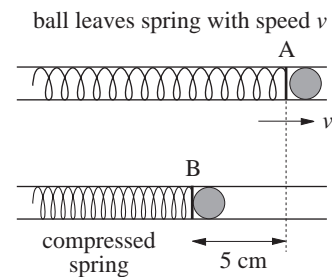

and

$$v = 10 \text{ ms}^{-1},$$

so that the ball leaves the spring with a velocity of 10 ms^{-1} .

Activity 11 Bungee jumping

You will need shirring elastic, some masses, a metre rule, a table and chair.

You may have seen a film of a stunt where people tie themselves with an elastic rope to a bridge and then jump off. This is known as **bungee jumping**. This activity simulates it safely in the classroom.

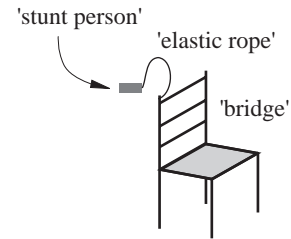

Set up the equipment as illustrated in the diagram.

For a given 'person', bridge and rope determine the critical length for the person to survive the jump.

Model the situation mathematically.

Does your result validate the model?

In the last examples in Section 6.3 when gravity is the only force acting, mechanical energy is conserved. This result is useful in solving this type of problem and leads to quicker solutions than using the equation of motion. The conservation of mechanical energy is used again in the next chapter. Remember that there are situations when mechanical energy is not conserved, in particular when friction and air resistance are included in the models.

The next example shows that the work-energy equation is a more general result which is applicable even when mechanical energy is not conserved.

Example

A 15 tonne wagon travelling at 3.6 ms^{-1} is brought to rest by a buffer (a spring) having a stiffness of $7.5 \times 10^5 \text{ Nm}^{-1}$. Assuming that the wagon comes into contact with the buffer smoothly without rebound, calculate the compression of the buffer if there is a constant rolling friction force of 800 N.

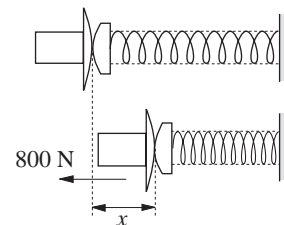

Solution

Since friction is included in this problem mechanical energy is **not** conserved. If x is the compression of the buffer when the wagon comes to rest, the forces acting on the wagon are the thrust

of the compressed spring and the friction 800 N, both acting in a direction opposite to the direction of motion.

The resultant force is

$$-800 - kx = -800 - 7.5 \times 10^5 x.$$

The work done by these forces = $\int_0^x (-7.5 \times 10^5 x - 800) dx$

$$= -7.5 \times 10^5 \frac{x^2}{2} - 800x.$$

The wagon comes to rest and so, remembering that 1 tonne = 10^3 kg, equation (18) with $v = 0$ and $u = 3.6 \text{ ms}^{-1}$ becomes

$$-7.5 \times 10^5 \frac{x^2}{2} - 800x = -\frac{1}{2} 15 \times 10^3 \times (3.6)^2$$

or

$$7.5 \times 10^5 x^2 + 16 \times 10^2 x = 15 \times 10^3 \times (3.6)^2$$

which simplifies to

$$750x^2 + 1.6x - 194.4 = 0.$$

This is a quadratic equation whose roots are

$$\begin{aligned} x &= \frac{-1.6 \pm \sqrt{(1.6)^2 + 4 \times 750 \times 194.4}}{1500} \\ &= \frac{-1.6 \pm 763.677}{1500} \\ &= 0.508 \quad \text{or} \quad -0.510. \end{aligned}$$

For this problem the negative root has no physical significance and so the required compression is 0.508 m.

Exercise 6F

1. A 100 g mass is attached to the end of an elastic string which hangs vertically with the other end fixed.

The string has stiffness 8 Nm^{-1} and natural length 0.25 m. If the mass is pulled downwards until the length of the string is 0.5 m and released, show that the mass comes to rest when the string becomes slack.

2. The mass in Question 1 is replaced by a 75 g mass. Find
 - (a) the velocity of the mass when the string first becomes slack;
 - (b) the distance below the fixed point where the mass comes to rest again.
3. The 100 g mass in Question 1 is now released from rest at the point where the string is fixed. Find the extension of the string when the mass first comes to rest. Find the speed of the mass when the string becomes slack and show that the mass does not come to rest before reaching the fixed point.
4. A cable is used to suspend a 800 kg safe. If the safe is being lowered at 6 ms^{-1} when the motor controlling the cable suddenly jams, determine the maximum tension in the cable. Neglect the mass of the cable and assume the cable is elastic such that it stretches 20 mm when subjected to a tension of 4 kN.
5. A mass m is attached to one end B of an elastic string AB of natural length l . The end A of the string is fixed and the mass falls vertically from rest at A. In the subsequent motion, the greatest depth of the mass below A is $3l$. Calculate the stiffness of the string.
6. A 0.5 kg mass is attached to the end of an elastic string of natural length 2 m and stiffness 0.5 Nm^{-1} . The other end A is fixed to a point on a smooth horizontal plane. The mass is projected from A along the plane at a speed of 4 ms^{-1} .

Find the greatest distance from A during the subsequent motion. Show that when the string is taut and the extension is x m the velocity v of the mass is given by $v^2 = 16 - x^2$.

By differentiating this equation with respect to t

show that the acceleration $\frac{d^2x}{dt^2}$ of the mass is

given by $\frac{d^2x}{dt^2} = -x$.

At what distance from A are the maximum values of

- (a) the velocity;
 - (b) the deceleration?
7. An energy-absorbing car bumper with its springs initially undeformed has spring stiffness of 525 kN m^{-1} . The 1200 kg car approaches a massive wall with a speed of 8 kph. Modelling the car as the mass spring system shown in the diagram, determine
- (a) the velocity of the car during contact with the wall when the spring is compressed a distance x m
 - (b) the maximum compression of the spring.

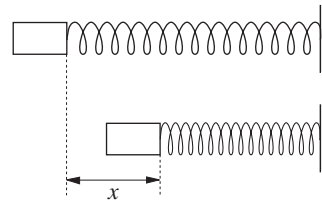

6.8 Using scalar products

If a constant force \mathbf{F} moves through a displacement \mathbf{d} and the angle between the vectors \mathbf{F} and \mathbf{d} is θ , then the work done by \mathbf{F} is found by multiplying the magnitude of the component of \mathbf{F} parallel to \mathbf{d} by the distance moved.

$$\text{Work done by } \mathbf{F} = |\mathbf{F}| \cos \theta |\mathbf{d}|,$$

$$\text{however } |\mathbf{F}| |\mathbf{d}| \cos \theta = \mathbf{F} \cdot \mathbf{d}.$$

So, when force \mathbf{F} is applied to a body while its position vector changes by \mathbf{d} , the work done is $\mathbf{F} \cdot \mathbf{d}$.

Example

Find the work done by a force $(2\mathbf{i} + 2\mathbf{j} - \mathbf{k}) \text{ N}$ which moves a body from the origin to a point P, position vector $(\mathbf{i} + \mathbf{j} + \mathbf{k}) \text{ m}$.

Solution

$$\begin{aligned}\text{Work done} &= (2\mathbf{i} + 2\mathbf{j} - \mathbf{k}) \cdot (\mathbf{i} + \mathbf{j} + \mathbf{k}) \\ &= 2 + 2 - 1 \\ &= 3 \text{ N.}\end{aligned}$$

Example

A particle of mass 3 kg is acted upon by three forces

$$\mathbf{F}_1 = \mathbf{i} + 2\mathbf{k}, \quad \mathbf{F}_2 = 3\mathbf{j} + 4\mathbf{k} \quad \text{and} \quad \mathbf{F}_3 = 2\mathbf{i} + 3\mathbf{j}.$$

If the particle moves from the point $\mathbf{i} - \mathbf{j} - \mathbf{k}$ to $3(\mathbf{i} + \mathbf{j} + \mathbf{k})$, find the work done by the resultant.

Solution

$$\begin{aligned}\text{The displacement vector } \mathbf{d} &= 3(\mathbf{i} + \mathbf{j} + \mathbf{k}) - (\mathbf{i} - \mathbf{j} - \mathbf{k}) \\ &= 2\mathbf{i} + 4\mathbf{j} + 4\mathbf{k}.\end{aligned}$$

$$\begin{aligned}\text{Work done by } \mathbf{F}_1 &= \mathbf{F}_1 \cdot \mathbf{d} \\ &= (\mathbf{i} + 2\mathbf{k}) \cdot (2\mathbf{i} + 4\mathbf{j} + 4\mathbf{k}) \\ &= 2 + 0 + 8 = 10.\end{aligned}$$

$$\begin{aligned}\text{Work done by } \mathbf{F}_2 &= \mathbf{F}_2 \cdot \mathbf{d} \\ &= (3\mathbf{j} + 4\mathbf{k}) \cdot (2\mathbf{i} + 4\mathbf{j} + 4\mathbf{k}) \\ &= 0 + 12 + 16 \\ &= 28.\end{aligned}$$

$$\begin{aligned}\text{Work done by } \mathbf{F}_3 &= \mathbf{F}_3 \cdot \mathbf{d} \\ &= (2\mathbf{i} + 3\mathbf{j}) \cdot (2\mathbf{i} + 4\mathbf{j} + 4\mathbf{k}) \\ &= 4 + 12 + 0 \\ &= 16.\end{aligned}$$

$$\begin{aligned}\text{The resultant force } \mathbf{F} &= \mathbf{F}_1 + \mathbf{F}_2 + \mathbf{F}_3 \\ &= (\mathbf{i} + 2\mathbf{k}) + (3\mathbf{j} + 4\mathbf{k}) + (2\mathbf{i} + 3\mathbf{j}) \\ &= 3\mathbf{i} + 6\mathbf{j} + 6\mathbf{k}.\end{aligned}$$

$$\begin{aligned}\text{Total work done by } \mathbf{F} &= \mathbf{F} \cdot \mathbf{d} \\ &= (3\mathbf{i} + 6\mathbf{j} + 6\mathbf{k}) \cdot (2\mathbf{i} + 4\mathbf{j} + 4\mathbf{k}) \\ &= (3 \times 2) + (6 \times 4) + (6 \times 4) \\ &= 54.\end{aligned}$$

This example shows that, when a set of forces act on a particle, the total work done by the individual forces is equal to the work done by the resultant.

The work done by a variable force \mathbf{F} can be defined as

$\int \mathbf{F} \cdot \mathbf{v} dt$ and, since power is the rate of doing work, power is given by $\mathbf{F} \cdot \mathbf{v}$. Using vector notation means that the scalar product can be used to good effect.

Example

A 5 kg mass moves so that its position vector \mathbf{r} at time t is given by $\mathbf{r} = \sin 2t \mathbf{i} + \cos 2t \mathbf{j} + 2t \mathbf{k}$. Find (a) the kinetic energy and (b) the work done between $t = 0$ and $t = 2$.

Solution

Since $\mathbf{r} = \sin 2t \mathbf{i} + \cos 2t \mathbf{j} + 2t \mathbf{k}$

then $\frac{d\mathbf{r}}{dt} = \mathbf{v} = 2 \cos 2t \mathbf{i} - 2 \sin 2t \mathbf{j} + 2 \mathbf{k}$

and $\frac{d\mathbf{v}}{dt} = \mathbf{a} = -4 \sin 2t \mathbf{i} - 4 \cos 2t \mathbf{j}$

Hence $\mathbf{F} = m \mathbf{a} = 5(-4 \sin 2t \mathbf{i} - 4 \cos 2t \mathbf{j})$

(a) Kinetic energy is given by

$$\begin{aligned} \text{KE} &= \frac{1}{2} m v^2 \\ &= \frac{1}{2} \times 5 \times (2 \cos 2t \mathbf{i} - 2 \sin 2t \mathbf{j} + 2 \mathbf{k}) \cdot (2 \cos 2t \mathbf{i} - 2 \sin 2t \mathbf{j} + 2 \mathbf{k}) \\ &= \frac{5}{2} \times (4 \cos^2 2t + 4 \sin^2 2t + 4) \\ &= \frac{5}{2} \times (4 + 4) \\ &= 20 \text{ J.} \end{aligned}$$

(b) The work done is given by

$$\begin{aligned} \text{WD} &= \int \mathbf{F} \cdot \mathbf{v} dt \\ &= \int 5(-4 \sin 2t \mathbf{i} - 4 \cos 2t \mathbf{j}) \cdot (2 \cos 2t \mathbf{i} - 2 \sin 2t \mathbf{j} + 2 \mathbf{k}) dt \\ &= \int 5(-8 \sin 2t \cos 2t + 8 \sin 2t \cos 2t + 0) dt \\ &= 0. \end{aligned}$$

Exercise 6G

- The force vector \mathbf{F} ($3\mathbf{i} + \mathbf{j} + 7\mathbf{k}$) moves a particle from the origin to the position vector ($6\mathbf{i} + 2\mathbf{j} - \mathbf{k}$). Find the work done by the force \mathbf{F} .
- Three forces $\mathbf{A} = 2\mathbf{i} + 4\mathbf{j} - \mathbf{k}$, $\mathbf{B} = 4\mathbf{i} - 7\mathbf{j} - 4\mathbf{k}$ and $\mathbf{C} = 3\mathbf{i} + 5\mathbf{j} - 4\mathbf{k}$ are acting on a particle which is displaced from $3\mathbf{i} + 2\mathbf{j} + \mathbf{k}$ to $15\mathbf{i} + 6\mathbf{j} + 3\mathbf{k}$.
 - Find the work done by each of the forces.
 - Find the resultant force and the work done by this force.
- A mass m moves such that its position vector \mathbf{r} is given by $(\frac{1}{3}t^3\mathbf{i} + \frac{1}{2}t^2\mathbf{j} + t\mathbf{k})$. Find
 - the kinetic energy of the mass;
 - the force acting on the mass;
 - the power exerted by this force.
- A force $(-\mathbf{i} + 3\mathbf{j})$ acts on a body of mass 5 kg. If the body has an initial velocity $(2\mathbf{i} - \mathbf{j})$ show, by considering the impulse by the force, that 5 s later the body is moving at right angles to its initial direction.

6.9 Miscellaneous Exercises

- On a building site a bucket of mass m , attached to an inextensible rope over a pulley is 10 m above the ground. A counterweight whose mass is $\frac{3}{4}$ that of the bucket is attached to the other end of the rope at ground level. If the system is released from rest what is the speed of the bucket when it reaches the ground?

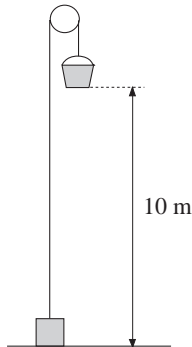

- A mass m is suspended from a fixed point A by an elastic string of natural length l and stiffness $4mg$. The mass is pulled down a distance d from its equilibrium position and then released. If it just reaches A find d .
- An archaeologist investigates the mechanics of large catapults used in sieges of castles. The diagram shows a simplified plan of such a catapult about to be fired horizontally.

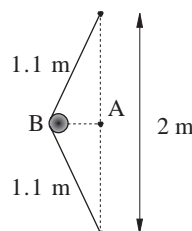

The rock B of mass 20 kg is in the catapult as shown. Calculate the speed with which the rock is released at A when the elastic string returns to its natural length of 2 m if the string's stiffness is 250 Nm^{-1}

- A platform P has negligible mass and is tied down so that the 0.4 m long cords keep the spring compressed 0.6 m when nothing is on the platform. The stiffness of the spring is 200 Nm^{-1} . If a 2 kg block is placed on the platform and released when the platform is pushed down 0.1 m, determine the velocity with which the block leaves the platform and the maximum height it subsequently reaches.

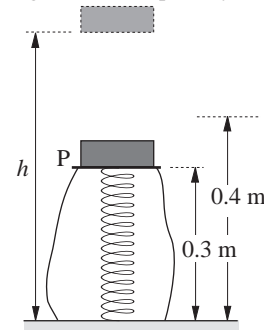

- A 10 kg block rests on a rough horizontal table. The spring, which is not attached to the block, has a stiffness $k = 500 \text{ Nm}^{-1}$. If the spring is compressed 0.2 m and then released from rest determine the velocity of the block when it has moved through 0.4 m. The coefficient of friction between the block and the table is 0.2.

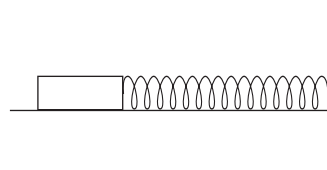

6. For a ball projected at speed u at an angle θ to the horizontal the speed v at a height y is given by $v^2 = u^2 - 2gy$.

Use the conservation of energy to derive this result.

7. An elastic string AB, of natural length l and modulus mg is fixed at one end A and to the other is attached a mass m . The mass hangs in equilibrium vertically below A. Determine the extension of the string. The mass is now pulled vertically downwards a further distance $\frac{1}{2}l$ and released from rest. Show that if x is the extension of the string from the equilibrium position the energy equation is

$$\frac{1}{2}m\left(\frac{dx}{dt}\right)^2 - mg(2l+x) + \frac{mg(l+x)^2}{2l} = \text{constant.}$$

Differentiating the equation with respect to t show that

$$\frac{d^2x}{dt^2} = -\frac{g}{l}x$$

and hence determine the acceleration of the mass when it is $\frac{7l}{4}$ below A.

Find the maximum values of velocity and acceleration.

8. A wagon of mass 2.5×10^3 kg travelling at 2 ms^{-1} is brought to rest by a buffer (a spring) having a stiffness of $5 \times 10^5 \text{ Nm}^{-1}$. Assuming that the wagon comes into contact smoothly without rebound, calculate the deflection of the buffer if there is a constant friction force of 7500 N. Discuss the effect of friction.
9. (In this question you should assume g is 9.8 ms^{-2}) The tension in a light elastic spring is given by Hooke's Law when the extension of the spring is x metres, where $0 \leq x \leq 0.5$. When $x = 0.5$ the tension is 7.35 N. Find the work done in increasing x from 0.2 to 0.5.

For $x > 0.5$ the tension is not given by Hooke's Law. Values of the tension T Newtons, for specific values of x in the range $0.5 \leq x \leq 0.9$ are given in the following table.

x	0.5	0.6	0.7	0.8	0.9
T	7.35	9.03	10.80	12.90	15.03

Using Simpson's rule, with five ordinates, show that the work done in increasing x from 0.5 to 0.9 is approximately 4.39 J.

A particle P is attached to one end of the spring and is suspended with the other end of the spring attached to a fixed point. Given that the particle

is in equilibrium when $x = 0.2$, show that the mass of the particle is 0.3 kg.

When the particle is at rest in the equilibrium position an impulse is applied to it so that it moves vertically downwards with an initial speed of 6 ms^{-1} . Given that the work done in extending the spring from $x = 0.5$ to $x = 0.9$ is exactly 4.39 J find the square of the speed of the particle when x is first equal to 0.9.

(AEB)

10. (In this question you should assume g is 9.8 ms^{-2})

When a car is moving on any road with speed $v \text{ ms}^{-1}$ the resistance to its motion is $(a + bv^2) \text{ N}$, where a and b are positive constants. When the car moves on a level road, with the engine working at a steady rate of 53 kW, it moves at a steady speed of 40 ms^{-1} . When the engine is working at a steady rate of 24 kW the car can travel on a level road at a steady speed of 30 ms^{-1} . Find a and b and hence deduce that, when the car is moving with speed 34 ms^{-1} , the resistance to its motion is 992 N.

Given that the car has mass 1200 kg find, in ms^{-2} correct to 2 decimal places, its acceleration on a level road at the instant when the engine is working at a rate of 51 kW and the car is moving with speed 34 ms^{-1} so that the resistance to the motion is 992 N.

The car can ascend a hill at a steady speed of 34 ms^{-1} with the engine working at a steady rate of 68 kW. Find, in degrees correct to one decimal place, the inclination of the hill to the horizontal.

(AEB)

11. A ball B of mass m is attached to one end of a light elastic string of natural length a and modulus $2mg$. The other end of the string is attached to a fixed point O. The ball is projected vertically upwards from O with speed $\sqrt{8ga}$; find the speed of the ball when $OB = 2a$.

Given that the string breaks when $OB = 2a$, find the speed of the ball when it returns to O.

(AEB)

12. (In this question you should assume g is 9.8 ms^{-2})

A lorry has mass 6 tonnes (6000 kg) and its engine can develop a maximum power of 10 kW. When the speed of the lorry is $v \text{ ms}^{-1}$ the total non-gravitational resistance to motion has magnitude $25v \text{ N}$. Find the maximum speed of the lorry when travelling

(a) along a straight horizontal road,

(b) up a hill which is inclined at an angle $\sin^{-1}(1/100)$ to the horizontal, giving your answer to 2 decimal places.

(AEB)

13. The position vector \mathbf{r} , relative to a fixed origin O, at time t of a particle P is given by

$$\mathbf{r} = a(\omega t - \sin \omega t)\mathbf{i} + a(\omega t + \cos \omega t)\mathbf{j}$$

where a and ω are positive constants. Determine the velocity and acceleration of P at time t and show that the acceleration is of constant magnitude.

Given that the particle is of mass m , find

- (a) the force acting on the particle,
 (b) the value of t in the interval $0 \leq t \leq \frac{\pi}{\omega}$ when the force is perpendicular to the velocity,
 (c) the kinetic energy when $t = \frac{\pi}{4\omega}$ and when

$$t = \frac{\pi}{\omega},$$

- (d) the work done by the force acting on the

$$\text{particle in the interval } \frac{\pi}{4\omega} \leq t \leq \frac{\pi}{\omega}.$$

(AEB)

14. Prove, by integration, that the work done in stretching an elastic string, of natural length l and modulus of elasticity λ , from length l to a length $l + x$ is $\frac{\lambda x^2}{2l}$.

A particle of mass m is suspended from a fixed point O by a light elastic string of natural length l . When the mass hangs freely at rest the length of the string is $\frac{13l}{12}$. The particle is now held at rest at O and released. Find the greatest extension of the string in the subsequent motion.

By considering the energy of the system when the length of the string is $l + x$ and the velocity of the particle is v explain why

$$\frac{1}{2}mv^2 = mg(l+x) - 6mg\frac{x^2}{l}.$$

Hence show that the kinetic energy of the particle in this position may be written as

$$\frac{mg}{l}\{\alpha l^2 - 6(x - \beta l)^2\},$$

where α and β are positive constants which must be found. Hence deduce that the maximum kinetic energy of the particle during the whole of its motion occurs when it passes through the equilibrium position.

(AEB)

15. One end of an elastic string of modulus $20mg$ and natural length a is attached to a point A on the surface of a smooth plane inclined at an angle of 30° to the horizontal. The other end is attached to a particle P of mass m . Initially P is held at rest at A and then released so that it slides down a line of greatest slope of the plane. By use of conservation of energy, or otherwise, show that the speed v of P when $AP = x$, ($x > a$), is given by

$$v^2 = \frac{g}{a}(41ax - 20a^2 - 20x^2).$$

- (a) Find the maximum value of v in the subsequent motion.
 (b) Find the maximum value of x in the subsequent motion. (AEB)
16. A train of mass 10^6 kg starts from rest and moves up a slope which is inclined at an angle $\arcsin(1/250)$ to the horizontal. Throughout its motion, the train's engines work at a power of 10^6 W and the train experiences a variable resistance. After 15 minutes, the train is moving with speed 20 ms^{-1} and has travelled a distance of 15 km along the slope. Taking $g = 9.8 \text{ ms}^{-2}$, find the increase in the kinetic and potential energies of the train during this 15 minute period and hence deduce the total work done against the resistance during this period. (AEB)

17. Two particles A and B, of mass $3m$ and $2m$ respectively, are attached to the ends of a light inextensible string which passes over a smooth fixed peg. The particles move freely in a vertical plane with both the hanging parts of the string vertical. Find the magnitude of the common acceleration of the particles and the tension in the string.

When the particle A is moving downwards with speed v it hits a horizontal inelastic table so that its speed is immediately reduced to zero.

Assume that B never hits the peg. Determine, in terms of v , m and g as appropriate,

- (a) the time that A is resting on the table after the first collision and before it is jerked off,
 (b) the speed with which A is first jerked off the table,
 (c) the difference between the total kinetic energy immediately before A first hits the table and the total kinetic energy immediately after A starts moving upwards for the first time,
 (d) the difference between the total kinetic energy immediately before A first hits the table and the total kinetic energy just after A starts moving upwards for the second time.

(AEB)

