

**MEGA LECTURE**

**Core 1**

At night, the light beam from a torch is shone into a swimming pool along the line TSA. Instead of striking the bottom of the pool at A, the beam travels to B, as shown on Fig. 1.

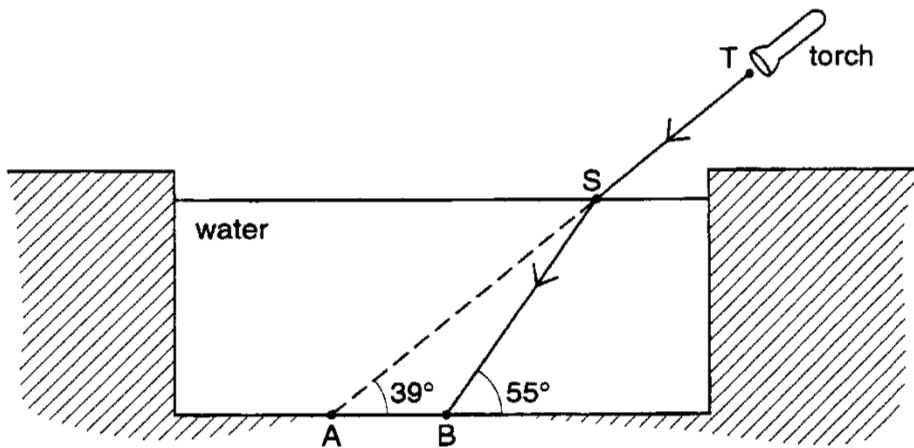

Fig. 1

- (a) At S, the direction of the beam changes. State the name we use to describe this change.  
.....[1]
- (b) (i) On Fig. 1, draw the normal to the surface at S.  
(ii) Clearly mark and label the angle of incidence. [2]
- (c) Fig. 2 shows the same pool and the same points A, B, S and T. The critical angle for the water is  $50^\circ$ .

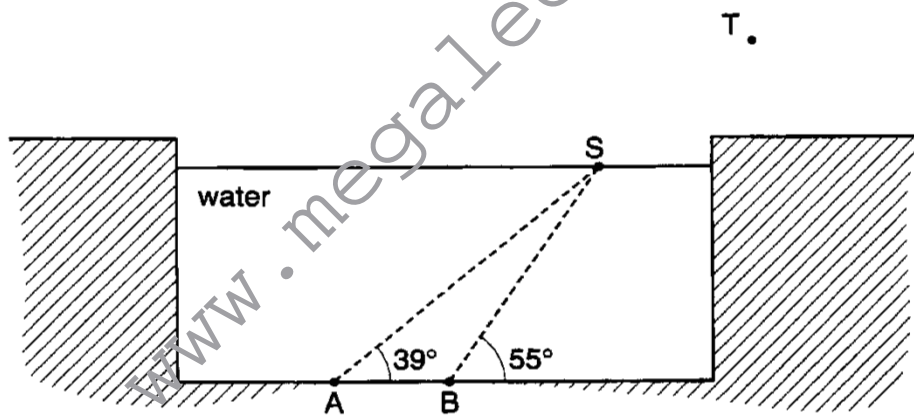
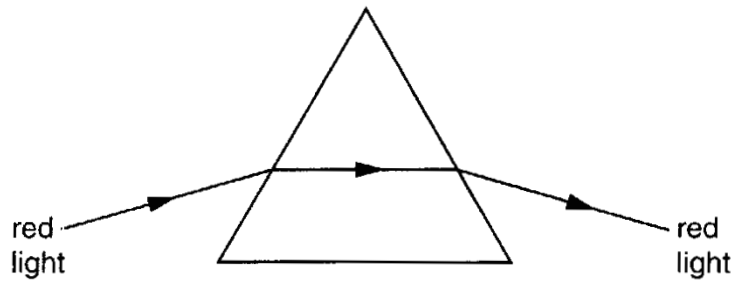

Fig. 1

- (i) A beam of light is directed up from B to S. On Fig. 2, carefully draw the path of the ray from B to S and then out into the air.
- (ii) 1. A beam of light is directed up from A to S. Describe what happens to the beam at S.  
.....  
.....
- 2. Explain why this happens.  
.....  
.....[4]

**Core 2**

(a) A ray of red light passes through a glass prism, as shown in Fig 3.

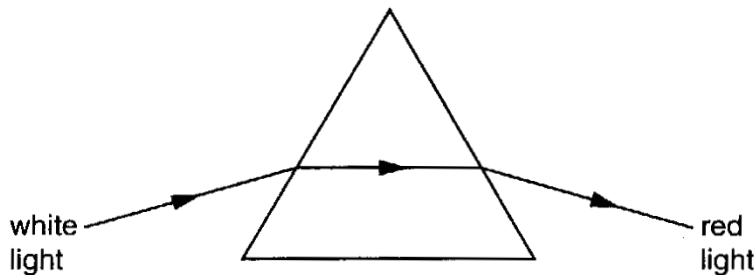

**Fig. 3**

What name do we use for the change of direction of the ray as it enters the glass?

.....[1]

(b) Fig. 4 shows the same prism, with white light passing through it. The path of red light is shown.



**Fig. 4**

(i) On Fig. 4, draw a possible path for blue light.

(ii) Something else is happening to the white light, in addition to what is shown in Fig. 3.

What name do we use for this? ..... [5]

(c) Light from the Sun is now passed through the prism. The path of red light is shown in Fig. 5.

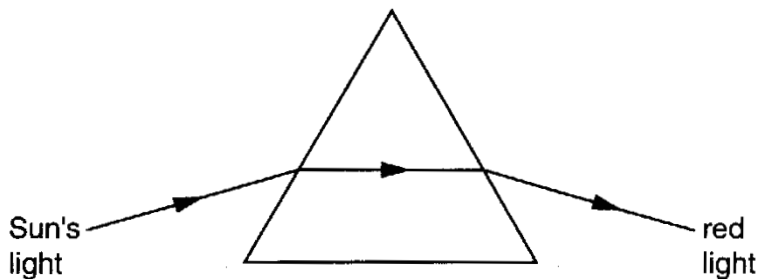
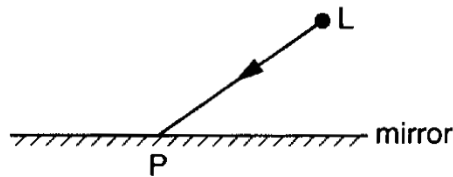

**Fig. 5**

We can detect infra-red rays using a thermocouple. On Fig. 5, mark with the letter T a position where the thermocouple could detect the infra-red rays after they have passed through the prism. [1]

**Core 3**

Fig. 6 shows a view from above of a vertical mirror. A small lamp is placed at the point marked L.



**Fig. 6**

- (a) One ray, LP, from the lamp has been drawn.
  - (i) At P, draw and label the normal to the mirror.
  - (ii) At P, draw and label the reflected ray.
  - (iii) Mark, using an X for each, two angles which are equal. [3]
- (b) Carefully mark, using a clear dot, the position of the image of the lamp. [1]
- (c) If you were looking into the mirror from point L, you might see something like Fig. 7 "looking back at you". (Apologies if you are better-looking than this!)

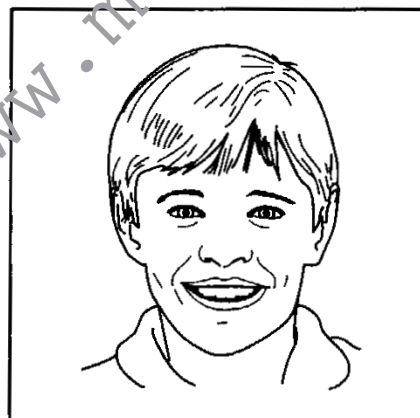

**Fig. 7**

- (i) Mark clearly with the letter **R**, the image of your right ear.
- (ii) Your nose is 30 cm from the mirror.  
How far from your nose is its image? ..... [2]



**Alternative to Practical 1**

Fig. 8 represents the apparatus an IGCSE class is using for an optics experiment, in which a glass beaker filled with water acts like a lens.

The glass beaker filled with water is placed with C, the centre of its base, on a line labelled LL'. An optics pin is placed at the point labelled O, so that the pin is touching the side of the beaker.

Two points A and A' are on the surface of the beaker at equal distances from the line LL'. The pin at point O acts as an optical object. The ray emerging from A is located by using two pins placed at two points labelled P<sub>1</sub> and P<sub>2</sub>.

- (a) Draw a neat, thin and accurate line to show the path of the ray from O to A in the water. Complete the path, in air, of the emerging ray along AP<sub>1</sub>P<sub>2</sub>. [3]
- (b) Produce the line P<sub>2</sub>P<sub>1</sub>A backwards so as to cut the line LL'. Label, with the letter I, the point where the two lines cross. Point I is the position of the image of the pin O when it is touching the side of the beaker. [2]
- (c) Draw the line OA' to represent a ray in water from O passing through A'. Using the information you gained in (b), draw a line to show the path of the ray in air after it passes through the point A'. Mark your diagram in such a way as to show how you found the direction of the ray in air. [1]
- (d) Take measurements to calculate the following ratio.

$$IR : OC = \dots : 1$$

Record your measurements and show your working.

$$IR : OC = \dots : 1 \qquad [2]$$

Alternative to Practical 1



glass beaker filled with water

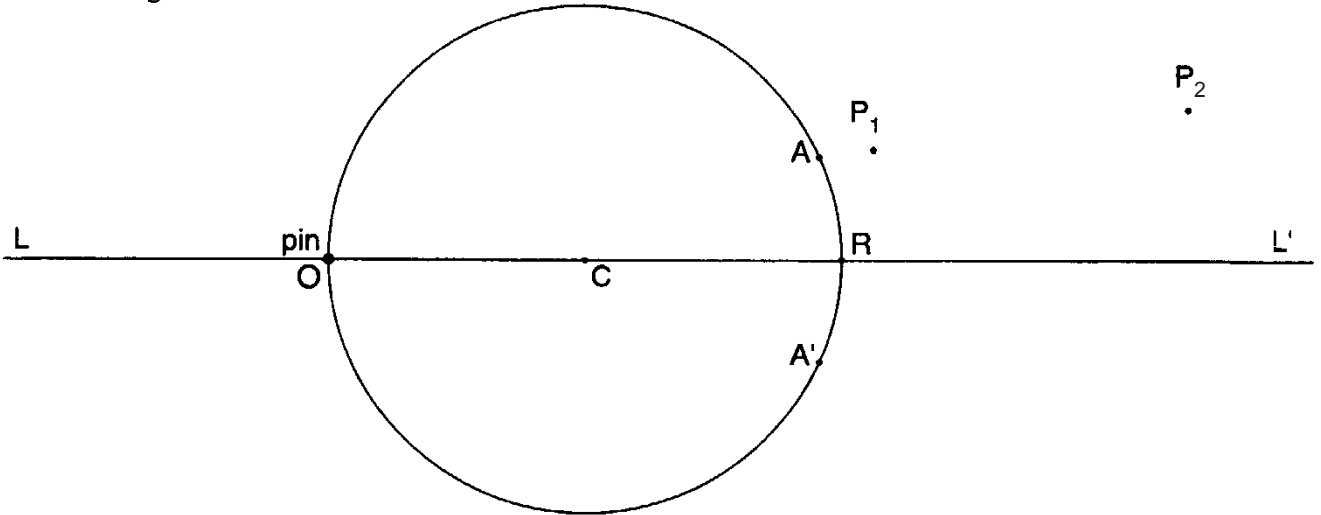

Fig. 8

www.megalecture.com

**Extension 1**

Fig. 9 shows an object placed 2.0 cm from a thin lens, which is to be used as a magnifying glass.

The focal length of the lens is 3.0 cm. The diagram is drawn to full scale.

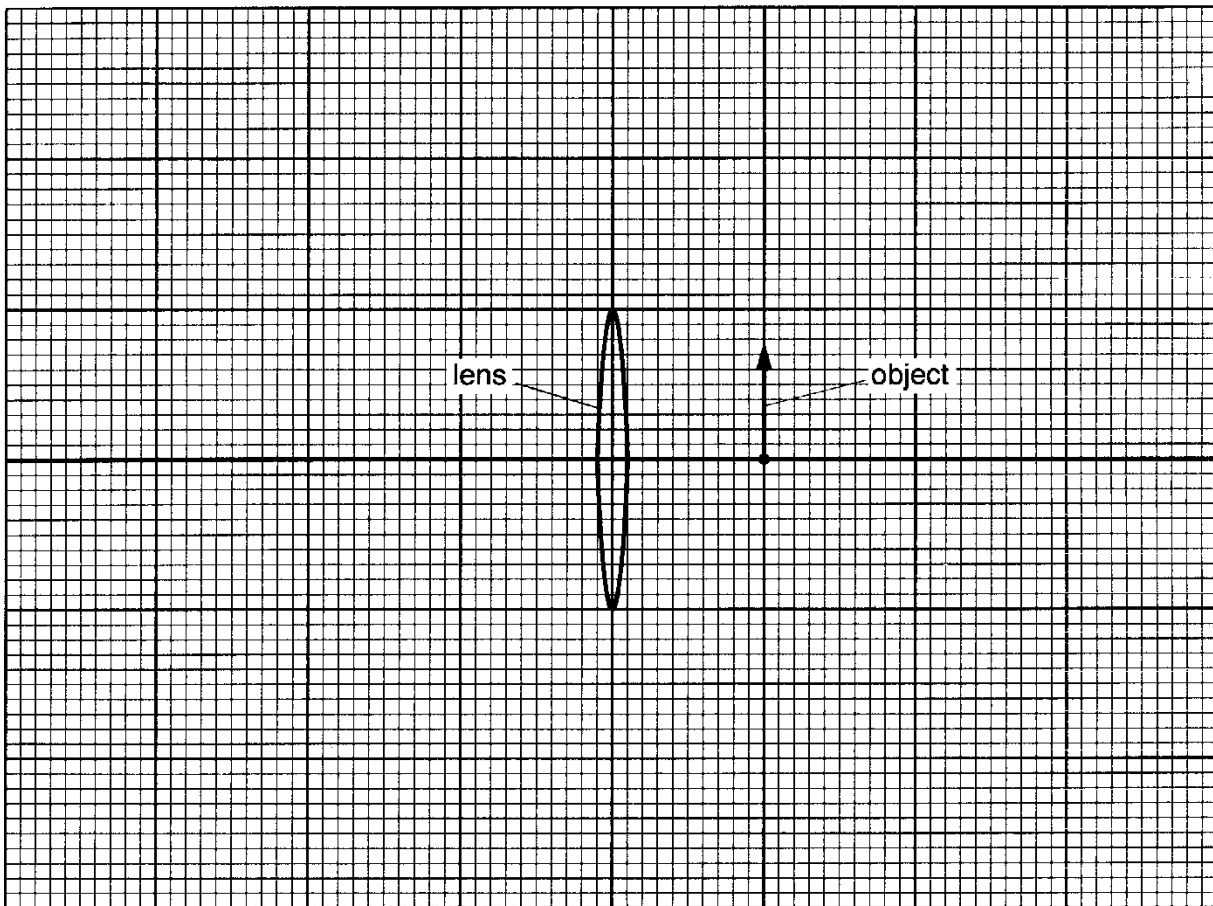

**Fig. 9**

- (a) On Fig. 9, draw any two rays from the tip of the object which enable you to locate the tip of the image. Draw in the image and label it I. [3]
- (b) On Fig. 9, draw in an eye position which would enable image I to be seen. [1]
- (c) By taking measurements from Fig. 9, work out how many times bigger the image is than the object.

The image is ..... times bigger than the object. [2]

**Extension 2**

Fig. 10 shows how a right-angled prism may be used to change the direction of a ray of light.

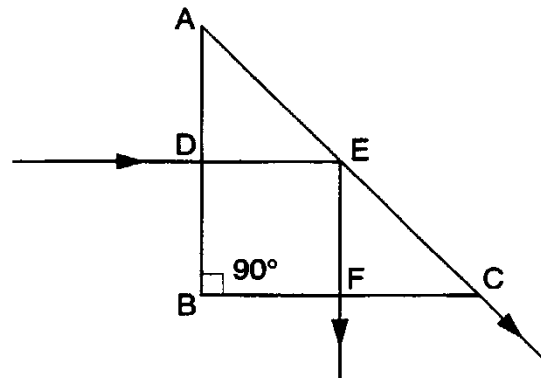

Fig. 10

(a) Explain why the ray of light does not change direction at D and at F.  
 .....[1]

(b) State **one** property of the light which does change at D and at F. At each point say whether it increases or decreases.  
 .....  
 .....[2]

(c) At E the light splits, with one ray along the surface of the prism and one ray along EF. Draw the normal at E. Label the critical angle with the letter X and state its value.  
 critical angle = ..... [2]

(d) The refractive index of this glass may be calculated using the formula  

$$\text{refractive index of glass} = 1/\sin c,$$
 where  $c$  is the critical angle.  
 Use your value of the critical angle of this glass to calculate its refractive index.  
 refractive index = ..... [2]



## Core 1

- a refraction
- b(i) the normal should be drawn at right angles to the surface of the water at S
- (ii) the angle of incidence should be shown between the normal and the incident ray
- c(i) the beam should be refracted away from the normal along ST
- (ii)
  - 1 total internal reflection
  - 2 the angle in the water is greater than the critical angle







## Core 2

- a refraction or deviation
- b(i) the blue path should show 2 downward refractions (i.e. below the path for red), one at each face
- (ii) dispersion
- c T should be shown just above the emergent red ray

[www.megalecture.com](http://www.megalecture.com)





### Core 3

- a(i) the normal should be shown at right angles to the mirror at P
- (ii) the reflected ray should be shown at the same angle to the normal as the incident ray by eye
- (ii) either angles  $i$  and  $r$  or the angles between the rays and the mirror
- b the dot should be shown on the reflected ray as far from the mirror as L is
- c(i) the ear on the right should be identified
- (ii) 60 cm





### Alternative to Practical 1

- a three marks are gained by
  - a neat thin line OA
  - a neat, thin line  $AP_1P_2$
  - an arrow from O
  
- b two marks are gained by
  - a neat line extended to LL'labelled I
  
- c the line should be a continuation of IA'
  
- d IR /OC should lie between 2.9 and 3.1 or to scale of diagram reproduced

[www.megalecture.com](http://www.megalecture.com)





### Extension 1

- a two of these
  - through either focus
  - through centre of curvature
  - ray produced back to form an image
- b the eye should be in a sensible position to the left of the lens
- c the image length should be  $4.5 \pm 0.2$ , approximately 3 times bigger than the object  
or according to the scale of the diagram





## Extension 2

- a the ray hits at right angles to the surface  
or angle  $i = 0^\circ$   
it travels along the normal
- b the velocity / speed / wavelength  
increases at F  
decreases at D
- c the value  $45^\circ$  should be stated or shown on the diagram
- d the refractive index =  $1 / \sin 45^\circ$   
 $= 1.4$

[www.megalecture.com](http://www.megalecture.com)

