

[Online Classes : Megalecture@gmail.com](mailto:Megalecture@gmail.com)  
[www.youtube.com/megalecture](http://www.youtube.com/megalecture)  
[www.megalecture.com](http://www.megalecture.com)

[www.youtube.com/megalecture](http://www.youtube.com/megalecture)

**MEGA LECTURE**

[www.megalecture.com](http://www.megalecture.com)

Topic

1

Quadratics

1. The equation of a curve is  $y = x^2 - 3x + 4$ .
  - (i) Show that the whole of the curve lies above the  $x$ -axis.
  - (ii) Find the set of values of  $x$  for which  $x^2 - 3x + 4$  is a decreasing function of  $x$ .  
The equation of a line is  $y + 2x = k$ , where  $k$  is a constant.
  - (iii) In the case where  $k = 6$ , find the coordinates of the points of intersection of the line and the curve.
  - (iv) Find the value of  $k$  for which the line is a tangent to the curve. [J05/P12/Q10]
  
2. The equation of a curve is  $xy = 12$  and the equation of a line  $l$  is  $2x + y = k$ , where  $k$  is a constant.
  - (i) In the case where  $k = 11$ , find the coordinates of the points of intersection of  $l$  and the curve.
  - (ii) Find the set of values of  $k$  for which  $l$  does not intersect the curve.
  - (iii) In the case where  $k = 10$ , one of the points of intersection is  $P(2, 6)$ . Find the angle, in degrees correct to 1 decimal place, between  $l$  and the tangent to the curve at  $P$ . [N05/P12/Q9]
  
3. Find the value of the constant  $c$  for which the line  $y = 2x + c$  is a tangent to the curve  $y^2 = 4x$ . [J07/P12/Q1]
  
4. Find the real roots of the equation  $\frac{18}{x^4} + \frac{1}{x^2} = 4$ . [J07/P12/Q4]
  
5. Determine the set of values of the constant  $k$  for which the line  $y = 4x + k$  does not intersect the curve  $y = x^2$ . [N07/P12/Q1]
  
6. The equation of a curve  $C$  is  $y = 2x^2 - 8x + 9$  and the equation of a line  $L$  is  $x + y = 3$ .
  - (i) Find the  $x$ -coordinates of the points of intersection of  $L$  and  $C$ .
  - (ii) Show that one of these points is also the stationary point of  $C$ . [J08/P12/Q4]
  
7. Find the set of values of  $k$  for which the line  $y = kx - 4$  intersects the curve  $y = x^2 - 2x$  at two distinct points. [J09/P12/Q2]



8.

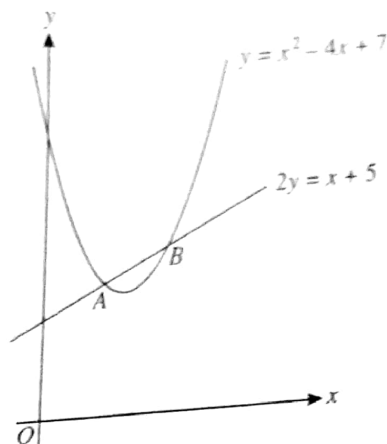

- (i) The diagram shows the line  $2y = x + 5$  and the curve  $y = x^2 - 4x + 7$ , which intersect at the points  $A$  and  $B$ . Find
- the  $x$ -coordinates of  $A$  and  $B$ ,
  - the equation of the tangent to the curve at  $B$ ,
  - the acute angle, in degrees correct to 1 decimal place, between this tangent and the line  $2y = x + 5$ .
- (ii) Determine the set of values of  $k$  for which the line  $2y = x + k$  does not intersect the curve  $y = x^2 - 4x + 7$ . [N09/P12/Q10]
9. A curve has equation  $y = kx^2 + 1$  and a line has equation  $y = kx$ , where  $k$  is a non-zero constant.
- Find the set of values of  $k$  for which the curve and the line have no common points.
  - State the value of  $k$  for which the line is a tangent to the curve and, for this case, find the coordinates of the point where the line touches the curve. [N10/P12/Q6]
10. Express  $2x^2 - 4x + 1$  in the form  $a(x + b)^2 + c$  and hence state the coordinates of the minimum point,  $A$ , on the curve  $y = 2x^2 - 4x + 1$ . [J11/P11/Q10(i)]
11. The equation  $x^2 + px + q = 0$ , where  $p$  and  $q$  are constants, has roots  $-3$  and  $5$ .
- Find the values of  $p$  and  $q$ .
  - Using these values of  $p$  and  $q$ , find the value of the constant  $r$  for which the equation  $x^2 + px + q + r = 0$  has equal roots. [J11/P12/Q3]
12. Find the set of values of  $m$  for which the line  $y = mx + 4$  intersects the curve  $y = 3x^2 - 4x + 7$  at two distinct points. [J11/P13/Q2]
13. A line has equation  $y = kx + 6$  and a curve has equation  $y = x^2 + 3x + 2k$ , where  $k$  is a constant.
- For the case where  $k = 2$ , the line and the curve intersect at points  $A$  and  $B$ . Find the distance  $AB$  and the coordinates of the mid-point of  $AB$ .
  - Find the two values of  $k$  for which the line is a tangent to the curve. [N11/P11/Q9]

14. The equation of a curve is  $y^2 + 2x = 13$  and the equation of a line is  $2y + x = k$ , where  $k$  is a constant.
- In the case where  $k = 8$ , find the coordinates of the points of intersection of the line and the curve.
  - Find the value of  $k$  for which the line is a tangent to the curve. [N11/P12/Q4]
15. (i) A straight line passes through the point  $(2, 0)$  and has gradient  $m$ . Write down the equation of the line.
- (ii) Find the two values of  $m$  for which the line is a tangent to the curve  $y = x^2 - 4x + 5$ . For each value of  $m$ , find the coordinates of the point where the line touches the curve.
- (iii) Express  $x^2 - 4x + 5$  in the form  $(x + a)^2 + b$  and hence, or otherwise, write down the coordinates of the minimum point on the curve. [N11/P13/Q7]

16.

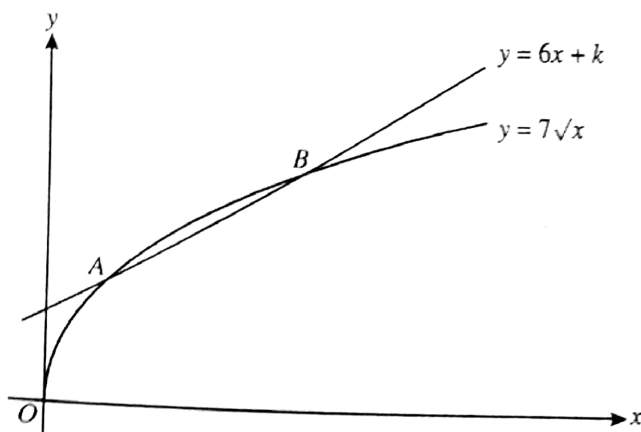

The diagram shows the curve  $y = 7\sqrt{x}$  and the line  $y = 6x + k$ , where  $k$  is a constant. The curve and the line intersect at the points  $A$  and  $B$ .

- For the case where  $k = 2$ , find the  $x$ -coordinates of  $A$  and  $B$ .
  - Find the value of  $k$  for which  $y = 6x + k$  is a tangent to the curve  $y = 7\sqrt{x}$ . [J12/P11/Q5]
17. The equation of a line is  $2y + x = k$ , where  $k$  is a constant, and the equation of a curve is  $xy = 6$ .
- In the case where  $k = 8$ , the line intersects the curve at the points  $A$  and  $B$ . Find the equation of the perpendicular bisector of the line  $AB$ .
  - Find the set of values of  $k$  for which the line  $2y + x = k$  intersects the curve  $xy = 6$  at two distinct points. [J12/P13/Q10]
18. The line  $y = \frac{x}{k} + k$ , where  $k$  is a constant, is a tangent to the curve  $4y = x^2$  at the point  $P$ . Find
- the value of  $k$ ,
  - the coordinates of  $P$ . [N12/P12/Q4]
19. A straight line has equation  $y = -2x + k$ , where  $k$  is a constant, and a curve has equation  $y = \frac{2}{x-3}$ .
- Show that the  $x$ -coordinates of any points of intersection of the line and curve are given by the equation  $2x^2 - (6 + k)x + (2 + 3k) = 0$ .
  - Find the

- The two tangents, given by the values of  $k$  found in part (ii), touch the curve at points  $A$  and  $B$ . [N12/P13/Q10]
- (iii) Find the coordinates of  $A$  and  $B$  and the equation of the line  $AB$ .
20. A curve has equation  $y = x^2 - 4x + 4$  and a line has equation  $y = mx$ , where  $m$  is a constant.
- (i) For the case where  $m = 1$ , the curve and the line intersect at the points  $A$  and  $B$ . Find the coordinates of the mid-point of  $AB$ .
- (ii) Find the non-zero value of  $m$  for which the line is a tangent to the curve, and find the coordinates of the point where the tangent touches the curve. [J13/P11/Q7]
21. The straight line  $y = mx + 14$  is a tangent to the curve  $y = \frac{12}{x} + 2$  at the point  $P$ . Find the value of the constant  $m$  and the coordinates of  $P$ . [J13/P12/Q3]
22. A curve has equation  $y = 2x^2 - 3x$ .
- (i) Find the set of values of  $x$  for which  $y > 9$ .
- (ii) Express  $2x^2 - 3x$  in the form  $a(x+b)^2 + c$ , where  $a$ ,  $b$  and  $c$  are constants, and state the coordinates of the vertex of the curve.
- The functions  $f$  and  $g$  are defined for all real values of  $x$  by
- $$f(x) = 2x^2 - 3x \quad \text{and} \quad g(x) = 3x + k,$$
- where  $k$  is a constant.
- (iii) Find the value of  $k$  for which the equation  $gf(x) = 0$  has equal roots. [N13/P12/Q10]
23. Solve the inequality  $x^2 - x - 2 > 0$ . [N13/P13/Q1]
24. (i) Express  $4x^2 - 12x$  in the form  $2x + a^2 + b$ .
- (ii) Hence, or otherwise, find the set of values of  $x$  satisfying  $4x^2 - 12x > 7$ . [J14/P11/Q2]
25. (i) Express  $2x^2 - 10x + 8$  in the form  $a(x+b)^2 + c$ , where  $a$ ,  $b$  and  $c$  are constants, and use your answer to state the minimum value of  $2x^2 - 10x + 8$ .
- (ii) Find the set of values of  $k$  for which the equation  $2x^2 - 10x + 8 = kx$  has no real roots. [J14/P13/Q8]
26. Find the set of values of  $k$  for which the line  $y = 2x - k$  meets the curve  $y = x^2 + kx - 2$  at two distinct points. [N14/P11/Q5]
27. (i) Express  $9x^2 - 12x + 5$  in the form  $(ax+b)^2 + c$ .
- (ii) Determine whether  $3x^3 - 6x^2 + 5x - 12$  is an increasing function, a decreasing function or neither. [N14/P13/Q3]
28. Express  $2x^2 - 12x + 7$  in the form  $a(x+b)^2 + c$ , where  $a$ ,  $b$  and  $c$  are constants. [J15/P13/Q1]

29. Solve the equation  $\sin^{-1}(4x^4 + x^2) = \frac{1}{6}\pi$ . [N15/P11/Q3]

30. A curve has equation  $y = x^2 - x + 3$  and a line has equation  $y = 3x + a$ , where  $a$  is a constant.

(i) Show that the  $x$ -coordinates of the points of intersection of the line and the curve are given by the equation  $x^2 - 4x + (3 - a) = 0$ .

(ii) For the case where the line intersects the curve at two points, it is given that the  $x$ -coordinate of one of the points of intersection is  $-1$ . Find the  $x$ -coordinate of the other point of intersection.

(iii) For the case where the line is a tangent to the curve at a point  $P$ , find the value of  $a$  and the coordinates of  $P$ . [ND15/P11/Q6]

31. A line has equation  $y = 2x - 7$  and a curve has equation  $y = x^2 - 4x + c$ , where  $c$  is a constant. Find the set of possible values of  $c$  for which the line does not intersect the curve. [N15/P13/Q1]

32. (a) Find the values of the constant  $m$  for which the line  $y = mx$  is a tangent to the curve  $y = 2x^2 - 4x + 8$ .

(b) The function  $f$  is defined for  $x \in \mathbb{R}$  by  $f(x) = x^2 + ax + b$ , where  $a$  and  $b$  are constants. The solutions of the equation  $f(x) = 0$  are  $x = 1$  and  $x = 9$ . Find

(i) the values of  $a$  and  $b$ ,

(ii) the coordinates of the vertex of the curve  $y = f(x)$ . [J16/P11/Q6]

33. (i) Express  $x^2 + 6x + 2$  in the form of  $(x + a)^2 + b$ , where  $a$  and  $b$  are constants. [2]

(ii) Hence, or otherwise, find the set of values of  $x$  for which  $x^2 + 6x + 2 > 9$ . [2]

[N16/P11/Q1]

34. A curve has equation  $y = 2x^2 - 6x + 5$ .

(i) Find the set of values of  $x$  for which  $y > 13$ . [3]

(ii) Find the value of the constant  $k$  for which the line  $y = 2x + k$  is a tangent to the curve. [3]

[N16/P12/Q3]

35. Find the set of values of  $k$  for which the curve  $y = kx^2 - 3x$  and the line  $y = x - k$  do not meet. [3]

[N16/P13/Q1]

# ANSWERS

## ~ Paper 1 ~

### Topic 1 - Quadratics

1. (i)  $y = x^2 - 3x + 4$   
 $= \left(x - \frac{3}{2}\right)^2 + \frac{7}{4}$

coordinate of minimum point is  $\left(\frac{3}{2}, \frac{7}{4}\right)$ .

$\therefore$  curve is above x-axis.

(ii)  $x < \frac{3}{2}$

(iii)  $(-1, 8), (2, 2)$ .

(iv) Discriminant = 0

$\Rightarrow (-1)^2 - 4(1)(4-k) = 0 \Rightarrow k = 3\frac{3}{4}$

2. (i)  $(1.5, 8)$  and  $(4, 3)$ .

(ii) Subst. line into curve,  $2x^2 - kx + 12 = 0$   
 apply, Discriminant  $< 0$

$\Rightarrow k^2 - 4(2)(12) < 0 \Rightarrow -\sqrt{96} < k < \sqrt{96}$

(iii) When  $k = 10$ ,  
 grad. of  $l$  at  $P$ :

$\tan \alpha = -2$

$\Rightarrow \alpha = 116.6^\circ$

grad. of curve at  $P$ :

$\tan \beta = -3$

$\Rightarrow \beta = 108.4^\circ$

req. angle  $\theta = \alpha - \beta$

$= 8.2^\circ$

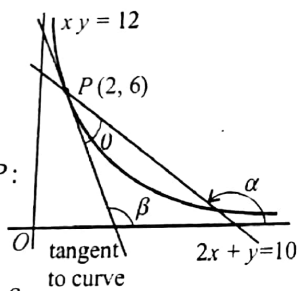

3. Subst. line into curve, apply, Disc. = 0

$c = \frac{1}{2}$

4.  $x = \pm \frac{3}{2}$ .

5. Subst. line into curve, apply, Disc.  $< 0$

$\Rightarrow k > -4$ .

6. (i) Subst. equation of line into curve,

$\therefore x = \frac{3}{2}$  or  $x = 2$ .

(ii)  $y = 2x^2 - 8x + 9$

$= 2(x-2)^2 + 1$

$\therefore (2, 1)$  is also the stationary point.

7. Subst. equation of line into curve,

apply discriminant  $> 0$

$\therefore k < -6$  or  $k > 2$ .

8. (i) (a)  $x = 3$  or  $x = \frac{3}{2}$ .

(b) Coordinates of  $B(3, 4)$

grad. of curve at  $B = 2$

$\therefore$  equation of tangent is  $2x - y = 2$ .

(c)

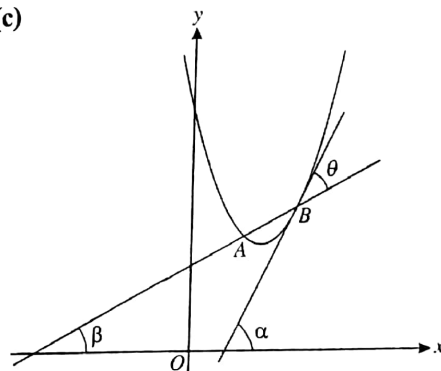

Grad. of tangent at  $B = 2$

$\Rightarrow \tan \alpha = 2$  or  $\alpha = 63.4^\circ$

grad. of line =  $\frac{1}{2}$

$\Rightarrow \tan \beta = \frac{1}{2}$  or  $\beta = 26.6^\circ$

req. angle  $\theta = \alpha - \beta$

$= 36.8^\circ$

(ii) Subst. equation of line into curve,  
 apply, discriminant  $< 0$

$\therefore k < 3.875$ .



9. (i) Subst. line into curve, apply,  $\text{Disc.} < 0$   
 $\therefore 0 < k < 4$   
 (ii) Apply, discriminant = 0  
 $\Rightarrow k = 4$   
 Point of intersection is  $\left(\frac{1}{2}, 2\right)$ .
10.  $2(x-1)^2 - 1$   
 minimum point  $A(1, -1)$ .
11. (i)  $p = -2, q = -15$   
 (ii) Apply,  $b^2 - 4ac = 0$   
 $\Rightarrow r = 16$
12. Substitute equation of line into curve.  
 Apply,  $b^2 - 4ac > 0$   
 $\therefore m < -10$  or  $m > 2$
13. (i)  $A(-2, 2), B(1, 8)$   
 Distance  $AB = 3\sqrt{5}$   
 Mid point of  $AB$  is  $\left(-\frac{1}{2}, 5\right)$   
 (ii) Substitute equation of line into curve.  
 Apply,  $b^2 - 4ac = 0$   
 $\therefore k = 3$  or  $11$ .
14. (i)  $(2, 3) (6, 1)$  Ans.  
 (ii) Solve the two equations simultaneously.  
 Apply,  $b^2 - 4ac = 0$ .  
 $\therefore k = 8.5$
15. (i)  $y = m(x-2)$  Ans.  
 (ii) Solve the two equations simultaneously.  
 Then apply,  $b^2 - 4ac = 0$ .  
 $\Rightarrow m = \pm 2$   
 Coordinates are  $(3, 2)$  and  $(1, 2)$ .  
 (iii)  $(x-2)^2 + 1$ , minimum point  $(2, 1)$ .
16. (i)  $x = \frac{1}{4}$  and  $x = \frac{4}{9}$   
 (ii) Solve the two equations simultaneously.  
 Then apply,  $b^2 - 4ac = 0$ .  
 $\Rightarrow k = 2.04$
17. (i) Solving simultaneously gives,  
 $A(2, 3), B(6, 1)$   
 Equation of  $\perp$  of  $AB$ :  
 $2x$
- (ii) Solve simultaneously.  
 Then apply,  $b^2 - 4ac > 0$ .  
 $\Rightarrow k < -\sqrt{48}$  and  $k > \sqrt{48}$
18. (i) Substitute equation of line into curve.  
 Apply,  $b^2 - 4ac = 0$   
 $\therefore k = -1$   
 (ii) Solving simultaneously gives,  $P(-2, 1)$ .
19. (i)  $\frac{2}{x-3} = -2x + k$   
 $\Rightarrow (x-3)(-2x+5) = 2$   
 $\Rightarrow 2x^2 - (k+6)x + (2+3k) = 0$ .  
 (ii) Substitute equation of line into curve.  
 Apply,  $b^2 - 4ac = 0$   
 $k = 2$  or  $10$   
 (iii)  $A(2, -2), B(4, 2)$   
 Equation of  $AB$ :  $2x - y = 6$ .
20. (i)  $A(1, 1), B(4, 4)$   
 Mid-point:  $\left(\frac{5}{2}, \frac{5}{2}\right)$   
 (ii) Solve the two equations simultaneously.  
 Then apply,  $b^2 - 4ac = 0$ .  
 $\Rightarrow m = -8$   
 Coordinates are  $(-2, 16)$
21.  $m = -3, P(2, 8)$
22. (i)  $x < -\frac{3}{2}$  or  $x > 3$ .  
 (ii)  $2\left(x - \frac{3}{4}\right)^2 - \frac{9}{8}$   
 coordinates  $\left(\frac{3}{4}, -\frac{9}{8}\right)$ .  
 (iii)  $\text{gf}(x) = 0 \Rightarrow 6x^2 - 9x + k = 0$   
 apply  $b^2 - 4ac = 0$   
 $\therefore k = 3\frac{3}{8}$
23.  $x < -1$  and  $x > 2$
24. (i)  $(2x-3)^2 - 9$   
 (ii)  $x < -\frac{1}{2}$  or  $x > 3\frac{1}{2}$

AL Mathematics (P1)

25. (i)  $2\left(x - \frac{5}{2}\right)^2 - \frac{9}{2}$ , min. point  $\left(\frac{5}{2}, -\frac{9}{2}\right)$

(ii) Apply,  $b^2 - 4ac < 0$ .  
 $\Rightarrow -18 < k < 2$  Ans.

26. Apply,  $b^2 - 4ac > 0$ .  
 $\Rightarrow k < 2$  or  $k > 6$ .

27. (i)  $(3x - 2)^2 + 1$

(ii)  $\frac{d}{dx}(3x^3 - 6x^2 + 5x - 12)$   
 $= (3x - 2)^2 + 1$  ( $> 0$ )  
 $\therefore$  Increasing function.

28.  $2(x - 3)^2 - 11$

29.  $4x^4 + x^2 = \frac{1}{2}$

$\Rightarrow 8x^4 + 2^2 - 1 = 0$

$\Rightarrow (2x^2 + 1)(4x^2 - 1) = 0 \Rightarrow x = \pm \frac{1}{2}$

30. (i)  $x^2 - x + 3 = 3x + a$

$\Rightarrow x^2 - 4x + (3 - a) = 0$ .

(ii) Substitute  $x = -1$  above gives  $a = 8$ .

$\therefore x^2 - 4x - 5 = 0$ .

$\Rightarrow x = 5$

(iii)  $x^2 - 4x + (3 - a) = 0$

apply  $b^2 - 4ac = 0$

$\Rightarrow a = -1$

Substitute  $a = -1$  gives coordinates of  $P(2, 5)$ .

31. Substitute equation of line into curve.

Apply, discriminant  $< 0$

$\Rightarrow 36 - 4(c + 7) < 0$

$\Rightarrow c > 2$

32. (a) Substitute equation of line into curve.

Apply, discriminant = 0

$\Rightarrow (4 + m)^2 - 64 = 0$

$\Rightarrow m = 4$  or  $-12$

(b) (i)  $a = -10$ ,  $b = 9$

(ii)  $f(x) = x^2 + ax + b$

$\Rightarrow y = x^2 - 10x + 9$

$\Rightarrow y = (x - 5)^2 - 16$

$\therefore$  coordinates of vertex are  $(5, -16)$

33. (i)  $(x + 3)^2 - 7$

(ii)  $(x + 3)^2 - 7 > 9$

$\Rightarrow (x + 3)^2 - 4^2 > 0$

$\Rightarrow (x - 1)(x + 7) > 0 \Rightarrow x < -7, x > 1$

34. (i)  $2x^2 - 6x + 5 > 13$

$\Rightarrow x^2 - 3x + 4 > 0$

$\Rightarrow (x - 4)(x + 1) > 0 \Rightarrow x < -1, x > 4$

(ii) Eliminating  $y$ , we have,

$2x + k = 2x^2 - 6x + 5$

$\Rightarrow 2x^2 - 8x + 5 - k = 0$

use,  $b^2 - 4ac = 0$

$\Rightarrow (-8)^2 - 4(2)(5 - k) = 0 \Rightarrow k = -3$

35. Eliminating  $y$ , we have,

$kx^2 - 4x + k = 0$

Apply, Disc  $< 0$

$\Rightarrow 16 - 4k^2 < 0$

$\Rightarrow k^2 - 4 > 0 \Rightarrow k < -2, k > 2$

29/7/11

$\mathbb{R} \rightarrow \mathbb{R}$

**Topic  
2**

**Functions and Graphs**

1. The functions  $f$  and  $g$  are defined as follows:

$$f: x \mapsto x^2 - 2x, \quad x \in \mathbb{R}$$

$$g: x \mapsto 2x + 3, \quad x \in \mathbb{R}$$

- (i) Find the set of values of  $x$  for which  $f(x) > 15$ .
- (ii) Find the range of  $f$  and state, with a reason, whether  $f$  has an inverse.
- (iii) Show that the equation  $gf(x) = 0$  has no real solutions.
- (iv) Sketch, in a single diagram, the graphs of  $y = g(x)$  and  $y = g^{-1}(x)$ , making clear the relationship between the graphs. [J04/P12/Q10]

2. The function  $f: x \mapsto 2x - a$ , where  $a$  is a constant, is defined for all real  $x$ .

- (i) In the case where  $a = 3$ , solve the equation  $ff(x) = 11$

The function  $g: x \mapsto x^2 - 6x$  is defined for all real  $x$ .

- (ii) Find the value of  $a$  for which the equation  $f(x) = g(x)$  has exactly one real solution.

The function  $h: x \mapsto x^2 - 6x$  is defined for the domain  $x \geq 3$ .

- (iii) Express  $x^2 - 6x$  in the form  $(x - p)^2 - q$ , where  $p$  and  $q$  are constants.
- (iv) Find an expression for  $h^{-1}(x)$  and state the domain of  $h^{-1}$ . [N04/P12/Q9]

3. A function  $f$  is defined by  $f: x \mapsto 3 - 2 \sin x$ , for  $0^\circ \leq x \leq 360^\circ$ .

- (i) Find the range of  $f$ .
- (ii) Sketch the graph of  $y = f(x)$ .

A function  $g$  is defined by  $g: x \mapsto 3 - 2 \sin x$ , for  $0^\circ \leq x \leq A^\circ$ , where  $A$  is a constant.

- (iii) State the largest value of  $A$  for which  $g$  has an inverse.
- (iv) When  $A$  has this value, obtain an expression, in terms of  $x$ , for  $g^{-1}(x)$ . [J05/P12/Q7]

4. A function  $f$  is defined by  $f: x \mapsto (2x - 3)^3 - 8$ , for  $2 \leq x \leq 4$ .

- (i) Find an expression, in terms of  $x$ , for  $f'(x)$  and show that  $f$  is an increasing function.
- (ii) Find an expression, in terms of  $x$ , for  $f^{-1}(x)$  and find the domain of  $f^{-1}$ . [N05/P12/Q8]

5. Functions  $f$  and  $g$  are defined by

$$f: x \mapsto k - x \quad \text{for } x \in \mathbb{R}, \text{ where } k \text{ is a constant,}$$

$$g: x \mapsto \frac{9}{x+2} \quad \text{for } x \in \mathbb{R}, x \neq -2.$$

- (i) Find the values of  $k$  for which the equation  $f(x) = g(x)$  has two equal roots and solve the equation  $f(x) = g(x)$  in these cases.



(ii) Solve the equation  $fg(x) = 5$  when  $k = 6$ .

(iii) Express  $g^{-1}(x)$  in terms of  $x$ .

[J06/P12/Q11]

6. The function  $f$  is defined by  $f: x \mapsto x^2 - 3x$  for  $x \in \mathbb{R}$ .

(i) Find the set of values of  $x$  for which  $f(x) > 4$ .

(ii) Express  $f(x)$  in the form  $(x-a)^2 - b$ , stating the values of  $a$  and  $b$ .

(iii) Write down the range of  $f$ .

(iv) State, with a reason, whether  $f$  has an inverse.

The function  $g$  is defined by  $g: x \mapsto x - 3\sqrt{x}$  for  $x \geq 0$ .

(v) Solve the equation  $g(x) = 10$ .

[N06/P12/Q10]

7.

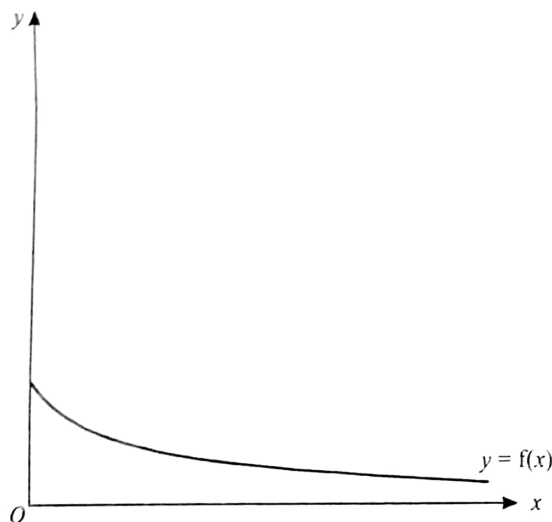

The diagram shows the graph of  $y = f(x)$ , where  $f: x \mapsto \frac{6}{2x+3}$  for  $x \geq 0$ .

(i) Find an expression, in terms of  $x$ , for  $f'(x)$  and explain how your answer shows that  $f$  is a decreasing function.

(ii) Find an expression, in terms of  $x$ , for  $f^{-1}(x)$  and find the domain of  $f^{-1}$ .

(iii) Copy the diagram and, on your copy, sketch the graph of  $y = f^{-1}(x)$ , making clear the relationship between the graphs.

The function  $g$  is defined by  $g: x \mapsto \frac{1}{2}x$  for  $x \geq 0$ .

(iv) Solve the equation  $fg(x) = \frac{3}{2}$ .

[J07/P12/Q11]

8. The function  $f$  is defined by  $f: x \mapsto 2x^2 - 8x + 11$  for  $x \in \mathbb{R}$ .

(i) Express  $f(x)$  in the form  $a(x+b)^2 + c$ , where  $a$ ,  $b$  and  $c$  are constants.

(ii) State the range of  $f$ .

[3]

[1]

(iii) Explain why  $f$  does not have an inverse.

The function  $g$  is defined by  $g: x \mapsto 2x^2 - 8x + 11$  for  $x \leq A$ , where  $A$  is a constant. [1]

(iv) State the largest value of  $A$  for which  $g$  has an inverse.

(v) When  $A$  has this value, obtain an expression, in terms of  $x$ , for  $g^{-1}(x)$  and state the range of  $g^{-1}$ . [N07/P12/Q11]

9. The function  $f$  is such that  $f(x) = (3x + 2)^3 - 5$  for  $x \geq 0$ .

(i) Obtain an expression for  $f'(x)$  and hence explain why  $f$  is an increasing function.

(ii) Obtain an expression for  $f^{-1}(x)$  and state the domain of  $f^{-1}$ .

[J08/P12/Q6]

10. Functions  $f$  and  $g$  are defined by

$$f: x \mapsto 4x - 2k \quad \text{for } x \in \mathbb{R}, \text{ where } k \text{ is a constant,}$$

$$g: x \mapsto \frac{9}{2-x} \quad \text{for } x \in \mathbb{R}, x \neq 2.$$

(i) Find the values of  $k$  for which the equation  $fg(x) = x$  has two equal roots.

(ii) Determine the roots of the equation  $fg(x) = x$  for the values of  $k$  found in part (i).

[J08/P12/Q8]

11. The function  $f$  is defined by

$$f: x \mapsto 3x - 2 \quad \text{for } x \in \mathbb{R}.$$

(i) Sketch, in a single diagram, the graphs of  $y = f(x)$  and  $y = f^{-1}(x)$ , making clear the relationship between the two graphs.

The function  $g$  is defined by

$$g: x \mapsto 6x - x^2 \quad \text{for } x \in \mathbb{R}.$$

(ii) Express  $gf(x)$  in terms of  $x$ , and hence show that the maximum value of  $gf(x)$  is 9.

The function  $h$  is defined by

$$h: x \mapsto 6x - x^2 \quad \text{for } x \geq 3.$$

(iii) Express  $6x - x^2$  in the form  $a - (x - b)^2$ , where  $a$  and  $b$  are positive constants.

(iv) Express  $h^{-1}(x)$  in terms of  $x$ .

[N08/P12/Q10]

12. The function  $f$  is defined by  $f: x \mapsto 2x^2 - 12x + 13$  for  $0 \leq x \leq A$ , where  $A$  is a constant.

(i) Express  $f(x)$  in the form  $a(x + b)^2 + c$ , where  $a$ ,  $b$  and  $c$  are constants.

(ii) State the value of  $A$  for which the graph of  $y = f(x)$  has a line of symmetry.

(iii) When  $A$  has this value, find the range of  $f$ .

The function  $g$  is defined by  $g: x \mapsto 2x^2 - 12x + 13$  for  $x \geq 4$ ,

(iv) Explain why  $g$  has an inverse.

(v) Obtain an expression, in terms of  $x$ , for  $g^{-1}(x)$ .

[J09/P12/Q10]

13. Functions  $f$  and  $g$  are defined by

$$f: x \mapsto 2x + 1, \quad x \in \mathbb{R}, x > 0,$$

$$g: x \mapsto 2x - 1$$

- (i) Solve the equation  $gf(x) = x$ .  
 (ii) Express  $f^{-1}(x)$  and  $g^{-1}(x)$  in terms of  $x$ .  
 (iii) Show that the equation  $g^{-1}(x) = x$  has no solutions.  
 (iv) Sketch in a single diagram the graphs of  $y = f(x)$  and  $y = f^{-1}(x)$ , making clear the relationship between the graphs. [N09/P11/Q10]

14. The function  $f$  is defined by  $f : x \mapsto 5 - 3\sin 2x$  for  $0 \leq x \leq \pi$

- (i) Find the range of  $f$ .  
 (ii) Sketch the graph of  $y = f(x)$ .  
 (iii) State, with a reason, whether  $f$  has an inverse. [N09/P12/Q4]

15. The function  $f$  is such that  $f(x) = \frac{3}{2x+5}$  for  $x \in \mathbb{R}$ ,  $x \neq -2.5$ .

- (i) Obtain an expression for  $f^{-1}(x)$  and explain why  $f$  is a decreasing function.  
 (ii) Obtain an expression for  $f^{-1}(x)$ . [N09/P12/Q8 (i)&(ii)]

16. The function  $f$  is such that  $f(x) = 2\sin^2 x - 3\cos^2 x$  for  $0 \leq x \leq \pi$ .

- (i) Express  $f(x)$  in the form  $a + b \cos^2 x$ , stating the values of  $a$  and  $b$ .  
 (ii) State the greatest and least values of  $f(x)$ .  
 (iii) Solve the equation  $f(x) + 1 = 0$ . [J10/P11/Q5]

17. The function  $f$  is defined by  $f : x \mapsto 2x^2 - 12x + 7$  for  $x \in \mathbb{R}$ .

- (i) Express  $f(x)$  in the form  $a(x-b)^2 - c$ .  
 (ii) State the range of  $f$ .  
 (iii) Find the set of values of  $x$  for which  $f(x) < 21$ .

The function  $g$  is defined by  $g : x \mapsto 2x + k$  for  $x \in \mathbb{R}$ .

- (iv) Find the value of the constant  $k$  for which the equation  $gf(x) = 0$  has two equal roots. [J10/P11/Q9]

18. The functions  $f$  and  $g$  are defined for  $x \in \mathbb{R}$  by

$$f : x \mapsto 4x - 2x^2,$$

$$g : x \mapsto 5x + 3.$$

- (i) Find the range of  $f$ .  
 (ii) Find the value of the constant  $k$  for which the equation  $gf(x) = k$  has equal roots. [J10/P12/Q3]

19. The function  $f : x \mapsto a + b \cos x$  is defined for  $0 \leq x \leq 2\pi$ . Given that  $f(0) = 10$  and that  $f(\frac{2}{3}\pi) = 1$ , find

- (i) the values of  $a$  and  $b$ ,  
 (ii) the range of  $f$ ,  
 (iii) the exact value of  $f(\frac{5}{6}\pi)$ . [J10/P13/Q3]



20. The function  $f : x \mapsto 2x^2 - 8x + 14$  is defined for  $x \in \mathbb{R}$ .
- Find the values of the constant  $k$  for which the line  $y + kx = 12$  is a tangent to the curve  $y = f(x)$ .
  - Express  $f(x)$  in the form  $a(x + b)^2 + c$ , where  $a$ ,  $b$  and  $c$  are constants.
  - Find the range of  $f$ .

The function  $g : x \mapsto 2x^2 - 8x + 14$  is defined for  $x \geq A$ .

- Find the smallest value of  $A$  for which  $g$  has an inverse.
- For this value of  $A$ , find an expression for  $g^{-1}(x)$  in terms of  $x$ .

[J10/P13/Q10]

21. Functions  $f$  and  $g$  are defined for  $x \in \mathbb{R}$  by

$$f : x \mapsto 2x + 3,$$

$$g : x \mapsto x^2 - 2x.$$

Express  $gf(x)$  in the form  $a(x + b)^2 + c$ , where  $a$ ,  $b$  and  $c$  are constants.

[N10/P11/Q3]

22. A function  $f$  is defined by  $f : x \mapsto 3 - 2 \tan\left(\frac{1}{2}x\right)$  for  $0 \leq x \leq \pi$ .

- State the range of  $f$ .
- State the exact value of  $f\left(\frac{2}{3}\pi\right)$ .
- Sketch the graph of  $y = f(x)$ .
- Obtain an expression, in terms of  $x$ , for  $f^{-1}(x)$ .

[N10/P11/Q7]

23. The function  $f$  is defined by

$$f(x) = x^2 - 4x + 7 \text{ for } x > 2.$$

- Express  $f(x)$  in the form  $(x - a)^2 + b$  and hence state the range of  $f$ .
- Obtain an expression for  $f^{-1}(x)$  and state the domain of  $f^{-1}$ .

The function  $g$  is defined by

$$g(x) = x - 2 \text{ for } x > 2.$$

The function  $h$  is such that  $f = hg$  and the domain of  $h$  is  $x > 0$ .

- Obtain an expression for  $h(x)$ .

[N10/P12/Q7]

24. The diagram shows the function  $f$  defined for  $0 \leq x \leq 6$  by

$$x \mapsto \frac{1}{2}x^2 \text{ for } 0 \leq x \leq 2,$$

$$x \mapsto \frac{1}{2}x + 1 \text{ for } 2 < x \leq 6.$$

- State the range of  $f$ .
- Copy the diagram and on your copy sketch the graph of  $y = f^{-1}(x)$ .
- Obtain expressions to define  $f^{-1}(x)$ , giving the set of values of  $x$  for which each expression is valid.

[N10/P13/Q7]

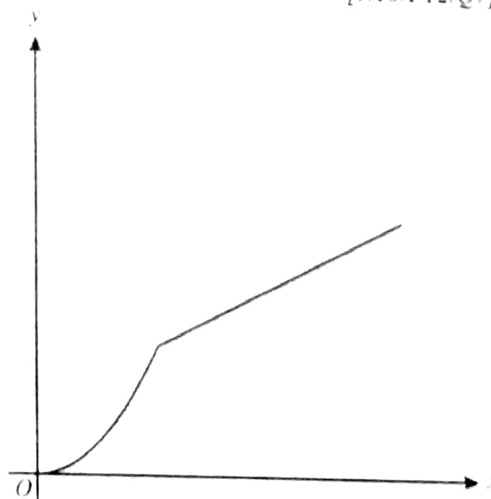

25. Functions  $f$  and  $g$  are defined for  $x \in \mathbb{R}$  by

$$f : x \mapsto 2x + 1,$$

$$g : x \mapsto x^2 - 2.$$

- (i) Find and simplify expressions for  $fg(x)$  and  $gf(x)$
- (ii) Hence find the value of  $a$  for which  $fg(a) = gf(a)$ .
- (iii) Find the value of  $b$  ( $b \neq a$ ) for which  $g(b) = b$ .
- (iv) Find and simplify an expression for  $f^{-1}g(x)$

The function  $h$  is defined by

$$h : x \mapsto x^2 - 2, \text{ for } x \leq 0$$

- (v) Find an expression for  $h^{-1}(x)$ .

[J11/P11/Q11]

26. The function  $f$  is defined by  $f : x \mapsto \frac{x+3}{2x-1}, x \in \mathbb{R}, x \neq \frac{1}{2}$

- (i) Show that  $ff(x) = x$ .
- (ii) Hence, or otherwise, obtain an expression for  $f^{-1}(x)$

[J11/P12/Q6]

27. Functions  $f$  and  $g$  are defined by

$$f : x \mapsto 3x - 4, \quad x \in \mathbb{R}$$

$$g : x \mapsto 2(x-1)^3 + 8, \quad x > 1.$$

- (i) Evaluate  $fg(2)$
- (ii) Sketch in a single diagram the graphs of  $y = f(x)$  and  $y = f^{-1}(x)$ , making clear the relationship between the graphs
- (iii) Obtain an expression for  $g^{-1}(x)$  and use your answer to explain why  $g$  has an inverse.
- (iv) Express each of  $f^{-1}(x)$  and  $g^{-1}(x)$  in terms of  $x$ .

[J11/P13/Q10]

28. Functions  $f$  and  $g$  are defined by

$$f : x \mapsto 2x^2 - 8x + 10 \quad \text{for } 0 \leq x \leq 2,$$

$$g : x \mapsto x \quad \text{for } 0 \leq x \leq 10.$$

- (i) Express  $f(x)$  in the form  $a(x+b)^2 + c$ , where  $a$ ,  $b$  and  $c$  are constants.
- (ii) State the range of  $f$ .
- (iii) State the domain of  $f^{-1}$ .
- (iv) Sketch on the same diagram the graphs of  $y = f(x)$ ,  $y = g(x)$  and  $y = f^{-1}(x)$ , making clear the relationship between the graphs.
- (v) Find an expression for  $f^{-1}(x)$

[N11/P11/Q11]

29. The functions  $f$  and  $g$  are defined for  $x \in \mathbb{R}$  by

$$f : x \mapsto 3x + a,$$

$$g : x \mapsto b - 2x,$$

where  $a$  and  $b$  are constants. Given that  $ff(2) = 10$  and  $g^{-1}(2) = 3$ , find

- (i) the values of  $a$  and  $b$ ,
- (ii) an expression for  $fg(x)$ .

[N11/P12/Q2]



30. Functions  $f$  and  $g$  are defined by

$$f: x \mapsto 2x + 3 \quad \text{for } x \leq 0,$$

$$g: x \mapsto x^2 - 6x \quad \text{for } x \leq 3.$$

- (i) Express  $f^{-1}(x)$  in terms of  $x$  and solve the equation  $f(x) = f^{-1}(x)$ .
- (ii) On the same diagram sketch the graphs of  $y = f(x)$  and  $y = f^{-1}(x)$ , showing the coordinates of their point of intersection and the relationship between the graphs.
- (iii) Find the set of values of  $x$  which satisfy  $gf(x) \leq 16$ .

[N11/P13/Q9]

31. The function  $f: x \mapsto x^2 - 4x + k$  is defined for the domain  $x \geq p$ , where  $k$  and  $p$  are constants.

- (i) Express  $f(x)$  in the form  $(x + a)^2 + b + k$ , where  $a$  and  $b$  are constants.
- (ii) State the range of  $f$  in terms of  $k$ .
- (iii) State the smallest value of  $p$  for which  $f$  is one-one.
- (iv) For the value of  $p$  found in part (iii), find an expression for  $f^{-1}(x)$  and state the domain of  $f^{-1}$ , giving your answers in terms of  $k$ .

[J12/P11/Q8]

32. Functions  $f$  and  $g$  are defined by

$$f: x \mapsto 2x + 5 \quad \text{for } x \in \mathbb{R},$$

$$g: x \mapsto \frac{8}{x-3} \quad \text{for } x \in \mathbb{R}, x \neq 3.$$

- (i) Obtain expressions, in terms of  $x$ , for  $f^{-1}(x)$  and  $g^{-1}(x)$ , stating the value of  $x$  for which  $g^{-1}(x)$  is not defined.
- (ii) Sketch the graphs of  $y = f(x)$  and  $y = f^{-1}(x)$  on the same diagram, making clear the relationship between the two graphs.
- (iii) Given that the equation  $fg(x) = 5 - kx$ , where  $k$  is a constant, has no solutions, find the set of possible values of  $k$ .

[J12/P12/Q10]

33. The function  $f$  is such that  $f(x) = 8 - (x - 2)^2$ , for  $x \in \mathbb{R}$ .

- (i) Find the coordinates and the nature of the stationary point on the curve  $y = f(x)$ .

The function  $g$  is such that  $g(x) = 8 - (x - 2)^2$ , for  $k \leq x \leq 4$ , where  $k$  is a constant.

- (ii) State the smallest value of  $k$  for which  $g$  has an inverse.

For this value of  $k$ ,

- (iii) find an expression for  $g^{-1}(x)$ ,

- (iv) sketch, on the same diagram, the graphs of  $y = g(x)$  and  $y = g^{-1}(x)$ .

[J12/P13/Q11]

34. The function  $f$  is defined by  $f(x) = 4x^2 - 24x + 11$ , for  $x \in \mathbb{R}$ .

- (i) Express  $f(x)$  in the form  $a(x - b)^2 + c$  and hence state the coordinates of the vertex of the graph of  $y = f(x)$ .

The function  $g$  is defined by  $g(x) = 4x^2 - 24x + 11$ , for  $x \leq 1$ .

- (ii) State the range of  $g$ .

- (iii) Find an expression for  $g^{-1}(x)$  and state the domain of  $g^{-1}$ .

[N12/P11/Q10]

35. A function  $f$  is such that  $f(x) = \sqrt{\left(\frac{x+3}{2}\right)} + 1$ , for  $x \geq -3$ . Find

- (i)  $f^{-1}(x)$  in the form  $ax^2 + bx + c$ , where  $a$ ,  $b$  and  $c$  are constants,
- (ii) the domain of  $f^{-1}$ .

[N12/P12/Q2]

36. The functions  $f$  and  $g$  are defined for  $-\frac{1}{2}\pi \leq x \leq \frac{1}{2}\pi$  by

$$f(x) = \frac{1}{2}x + \frac{1}{6}\pi,$$

$$g(x) = \cos x.$$

Solve the following equations for  $-\frac{1}{2}\pi \leq x \leq \frac{1}{2}\pi$ .

- (i)  $gf(x) = 1$ , giving your answer in terms of  $\pi$ .
- (ii)  $fg(x) = 1$ , giving your answers correct to 2 decimal places.

[N12/P13/Q6]

37.

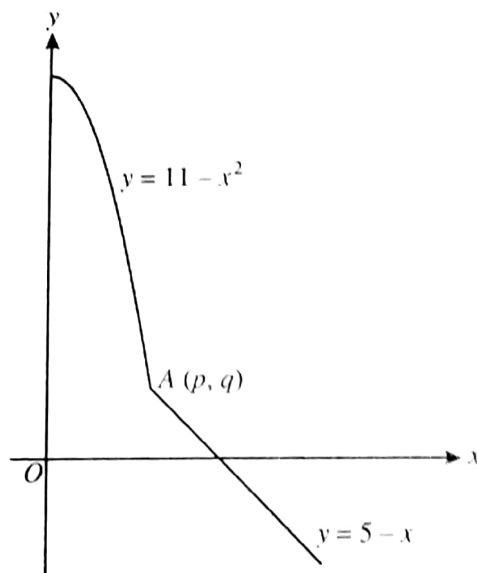

- (i) The diagram shows part of the curve  $y = 11 - x^2$  and part of the straight line  $y = 5 - x$  meeting at the point  $A(p, q)$ , where  $p$  and  $q$  are positive constants. Find the values of  $p$  and  $q$ .
- (ii) The function  $f$  is defined for the domain  $x \geq 0$  by

$$f(x) = \begin{cases} 11 - x^2 & \text{for } 0 \leq x \leq p, \\ 5 - x & \text{for } x > p. \end{cases}$$

Express  $f^{-1}(x)$  in a similar way.

[N12/P13/Q7]

- 38. (i) Express  $2x^2 - 12x + 13$  in the form  $a(x + b)^2 + c$ , where  $a$ ,  $b$  and  $c$  are constants.
- (ii) The function  $f$  is defined by  $f(x) = 2x^2 - 12x + 13$  for  $x \geq k$ , where  $k$  is a constant. It is given that  $f$  is a one-one function. State the smallest possible value of  $k$ .  
The value of  $k$  is now given to be 7.
- (iii) Find the range of  $f$ .



(iv) Find an expression for  $f^{-1}(x)$  and state the domain of  $f^{-1}$ .

[J13/P11/Q8]

39. A function  $f$  is defined by  $f(x) = \frac{5}{1-3x}$ , for  $x \geq 1$ .

(i) Find an expression for  $f^{-1}(x)$ .

*make visible*

(ii) Determine, with a reason, whether  $f$  is an increasing function, a decreasing function or neither.

(iii) Find an expression for  $f^{-1}(x)$ , and state the domain and range of  $f^{-1}$ .

[J13/P12/Q9]

40. The function  $f$  is defined by  $f: x \mapsto 2x+k$ ,  $x \in \mathbb{R}$ , where  $k$  is a constant.

(i) In the case where  $k=3$ , solve the equation  $ff(x) = 25$ .

The function  $g$  is defined by  $g: x \mapsto x^2 - 6x + 8$ ,  $x \in \mathbb{R}$ .

(ii) Find the set of values of  $k$  for which the equation  $f(x) = g(x)$  has no real solutions.

The function  $h$  is defined by  $h: x \mapsto x^2 - 6x + 8$ ,  $x > 3$ .

(iii) Find an expression for  $h^{-1}(x)$ .

[J13/P13/Q10]

41. The function  $f$  is defined by

$$f: x \mapsto x^2 + 1 \text{ for } x \geq 0.$$

(i) Define in a similar way the inverse function  $f^{-1}$ .

(ii) Solve the equation  $ff(x) = \frac{185}{16}$ .

[N13/P11/Q5]

42. A function  $f$  is defined by  $f: x \mapsto 3\cos x - 2$  for  $0 \leq x \leq 2\pi$ .

(i) Solve the equation  $f(x) = 0$ .

(ii) Find the range of  $f$ .

(iii) Sketch the graph of  $y = f(x)$ .

A function  $g$  is defined by  $g: x \mapsto 3\cos x - 2$  for  $0 \leq x \leq k$ .

(iv) State the maximum value of  $k$  for which  $g$  has an inverse.

(v) Obtain an expression for  $g^{-1}(x)$ .

[N13/P12/Q8]

43. The function  $f$  is defined by  $f: x \mapsto x^2 + 4x$  for  $x \geq c$ , where  $c$  is a constant. It is given that  $f$  is a one-one function.

(i) State the range of  $f$  in terms of  $c$  and find the smallest possible value of  $c$ .

The function  $g$  is defined by  $g: x \mapsto ax + b$  for  $x \geq 0$ , where  $a$  and  $b$  are positive constants. It is given that, when  $c = 0$ ,  $gf(1) = 11$  and  $fg(1) = 21$ .



- (ii) Write down two equations in  $a$  and  $b$  and solve them to find the values of  $a$  and  $b$ .

[N13/P13/Q10]

44.

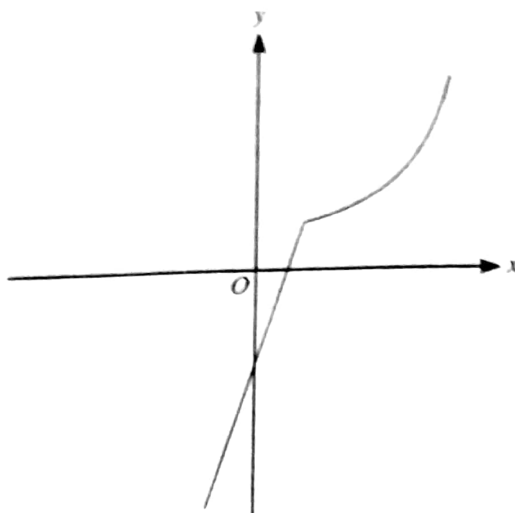

The diagram shows the function  $f$  defined for  $-1 \leq x \leq 4$ , where

$$f(x) = \begin{cases} 3x - 2 & \text{for } -1 \leq x \leq 1, \\ \frac{4}{5-x} & \text{for } 1 < x \leq 4. \end{cases}$$

- (i) State the range of  $f$ .  
 (ii) Copy the diagram and on your copy sketch the graph of  $y = f^{-1}(x)$ .  
 (iii) Obtain expressions to define the function  $f^{-1}$ , giving also the set of values for which each expression is valid.

[J14/P11/Q10]

45. Functions  $f$  and  $g$  are defined by

$$f : x \mapsto 2x - 3 \quad x \in \mathbb{R},$$

$$g : x \mapsto x^2 + 4x, \quad x \in \mathbb{R}.$$

- (i) Solve the equation  $ff(x) = 11$ .  
 (ii) Find the range of  $g$ .  
 (iii) Find the set of values of  $x$  for which  $g(x) > 12$ .  
 (iv) Find the value of the constant  $p$  for which the equation  $gf(x) = p$  has two equal roots.

Function  $h$  is defined by  $h : x \mapsto x^2 + 4x$  for  $x \geq k$ , and it is given that  $h$  has an inverse.

- (v) State the smallest possible value of  $k$ .  
 (vi) Find an expression for  $h^{-1}(x)$ .

[J14/P12/Q10]

46. A function  $f$  is such that  $f(x) = \frac{15}{2x+3}$  for  $0 \leq x \leq 6$ .

- (i) Find an expression for  $f'(x)$  and use your result to explain why  $f$  has an inverse.

- (ii) Find an expression for  $f^{-1}(x)$ , and state the domain and range of  $f^{-1}$ . [J14/P13/Q5]
47. (i) Express  $x^2 - 2x - 15$  in the form  $(x+a)^2 + b$ .  
The function  $f$  is defined for  $p \leq x \leq q$ , where  $p$  and  $q$  are positive constants, by  
$$f : x \mapsto x^2 - 2x - 15$$
  
The range of  $f$  is given by  $c \leq f(x) \leq d$ , where  $c$  and  $d$  are constants.  
(ii) State the smallest possible value of  $c$ .  
For the case where  $c = 9$  and  $d = 65$ ,  
(iii) find  $p$  and  $q$ ,  
(iv) find an expression for  $f^{-1}(x)$ . [N14/P11/Q10]
48. The function  $f : x \mapsto 6 - 4\cos\left(\frac{1}{2}x\right)$  is defined for  $0 \leq x \leq 2\pi$ .  
(i) Find the exact value of  $x$  for which  $f(x) = 4$ .  
(ii) State the range of  $f$ .  
(iii) Sketch the graph of  $y = f(x)$ .  
(iv) Find an expression for  $f^{-1}(x)$ . [N14/P12/Q11]
49. (a) The functions  $f$  and  $g$  are defined for  $x \geq 0$  by  
$$f : x \mapsto (ax + b)^{\frac{1}{3}}, \text{ where } a \text{ and } b \text{ are positive constants,}$$
  
$$g : x \mapsto x^2.$$
  
Given that  $fg(1) = 2$  and  $gf(9) = 16$ ,  
(i) calculate the values of  $a$  and  $b$ ,  
(ii) obtain an expression for  $f^{-1}(x)$  and state the domain of  $f^{-1}$ . [N14/P13/Q10(a)]
50. The function  $f : x \mapsto 5 + 3\cos\left(\frac{1}{2}x\right)$  is defined for  $0 \leq x \leq 2\pi$ .  
(i) Solve the equation  $f(x) = 7$ , giving your answer correct to 2 decimal places.  
(ii) Sketch the graph of  $y = f(x)$ .  
(iii) Explain why  $f$  has an inverse.  
(iv) Obtain an expression for  $f^{-1}(x)$ . [J15/P11/Q8]
51. The function  $f$  is defined by  $f : x \mapsto 2x^2 - 6x + 5$  for  $x \in \mathbb{R}$ .  
(i) Find the set of values of  $p$  for which the equation  $f(x) = p$  has no real roots.  
The function  $g$  is defined by  $g : x \mapsto 2x^2 - 6x + 5$  for  $0 \leq x \leq 4$ .  
(ii) Express  $g(x)$  in the form  $a(x+b)^2 + c$ , where  $a$ ,  $b$  and  $c$  are constants.  
(iii) Find the range of  $g$ .

The function  $h$  is defined by  $h : x \mapsto 2x^2 - 6x + 5$  for  $k \leq x \leq 4$ , where  $k$  is a constant.

- (iv) State the smallest value of  $k$  for which  $h$  has an inverse.  
 (v) For this value of  $k$ , find an expression for  $h^{-1}(x)$ .

[J15/P12/Q11]

52.

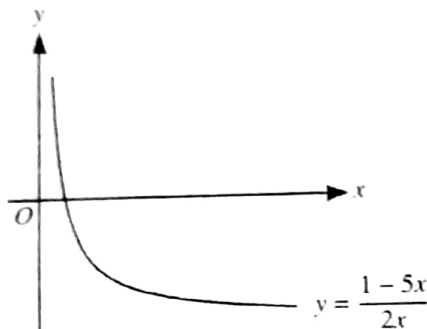

The diagram shows the graph of  $y = f^{-1}(x)$ , where  $f^{-1}$  is defined by  $f^{-1}(x) = \frac{1-5x}{2x}$  for  $0 < x \leq 2$ .

- (i) Find an expression for  $f(x)$  and state the domain of  $f$ .  
 (ii) The function  $g$  is defined by  $g(x) = \frac{1}{x}$  for  $x \geq 1$ . Find an expression for  $f^{-1}g(x)$ , giving your answer in the form  $ax + b$ , where  $a$  and  $b$  are constants to be found.

[J15/P13/Q6]

53. (i) Express  $-x^2 + 6x - 5$  in the form  $a(x+b)^2 + c$ , where  $a$ ,  $b$  and  $c$  are constants.

The function  $f : x \mapsto -x^2 + 6x - 5$  is defined for  $x \geq m$ , where  $m$  is a constant.

- (ii) State the smallest value of  $m$  for which  $f$  is one-one.  
 (iii) For the case where  $m = 5$ , find an expression for  $f^{-1}(x)$  and state the domain of  $f^{-1}$ .

[D15/P11/Q9]

54. Functions  $f$  and  $g$  are defined by

$$f : x \mapsto 3x + 2, \quad x \in \mathbb{R},$$

$$g : x \mapsto 4x - 12, \quad x \in \mathbb{R}.$$

Solve the equation  $f^{-1}(x) = gf(x)$ .

[D15/P12/Q1]

55. The function  $f$  is defined, for  $x \in \mathbb{R}$ , by  $f : x \mapsto x^2 + ax + b$ , where  $a$  and  $b$  are constants.

- (i) In the case where  $a = 6$  and  $b = -8$ , find the range of  $f$ .  
 (ii) In the case where  $a = 5$ , the roots of the equation  $f(x) = 0$  are  $k$  and  $-2k$ , where  $k$  is a constant. Find the values of  $b$  and  $k$ .  
 (iii) Show that if the equation  $f(x+a) = a$  has no real roots, then  $a^2 < 4(b-a)$ .

[D15/P12/Q8]

56. (i) Express  $3x^2 - 6x + 2$  in the form  $a(x+b)^2 + c$ , where  $a$ ,  $b$  and  $c$  are constants.  
 (ii) The function  $f$ , where  $f(x) = x^3 - 3x^2 + 7x - 8$ , is defined for  $x \in \mathbb{R}$ . Find  $f'(x)$  and state, with a reason, whether  $f$  is an increasing function, a decreasing function or neither. [D15/P13/Q3]

57. The function  $f$  is defined by  $f(x) = 3x + 1$  for  $x \leq a$ , where  $a$  is a constant. The function  $g$  is defined by  $g(x) = -1 - x^2$  for  $x \leq -1$ .  
 (i) Find the largest value of  $a$  for which the composite function  $gf$  can be formed.  
 For the case where  $a = -1$ ,  
 (ii) solve the equation  $fg(x) + 14 = 0$ ,  
 (iii) find the set of values of  $x$  which satisfy the inequality  $gf(x) \leq -50$ . [D15/P13/Q8]

58. The function  $f$  is defined by  $f: x \mapsto 4 \sin x - 1$  for  $-\frac{1}{2}\pi \leq x \leq \frac{1}{2}\pi$ .  
 (i) State the range of  $f$ .  
 (ii) Find the coordinates of the points at which the curve  $y = f(x)$  intersects the coordinate axes.  
 (iii) Sketch the graph of  $y = f(x)$ .  
 (iv) Obtain an expression for  $f^{-1}(x)$ , stating both the domain and range of  $f^{-1}$ . [J16/P11/Q11]

59. Functions  $f$  and  $g$  are defined by

$$f: x \mapsto 10 - 3x, \quad x \in \mathbb{R},$$

$$g: x \mapsto \frac{10}{3 - 2x}, \quad x \in \mathbb{R}, x \neq \frac{3}{2}.$$

Solve the equation  $ff(x) = gf(2)$ .

[J16/P12/Q1]

60. The function  $f$  is defined by  $f: x \mapsto 6x - x^2 - 5$  for  $x \in \mathbb{R}$ .  
 (i) Find the set of values of  $x$  for which  $f(x) \leq 3$ .  
 (ii) Given that the line  $y = mx + c$  is a tangent to the curve  $y = f(x)$ , show that  $4c = m^2 - 12m + 16$ .  
 The function  $g$  is defined by  $g: x \mapsto 6x - x^2 - 5$  for  $x \geq k$ , where  $k$  is a constant.  
 (iii) Express  $6x - x^2 - 5$  in the form  $a - (x - b)^2$ , where  $a$  and  $b$  are constants.  
 (iv) State the smallest value of  $k$  for which  $g$  has an inverse.  
 (v) For this value of  $k$ , find an expression for  $g^{-1}(x)$ . [J16/P12/Q11]

61. The function  $f$  is such that  $f(x) = 2x + 3$  for  $x \geq 0$ . The function  $g$  is such that  $g(x) = ax^2 + b$  for  $x \leq q$ , where  $a$ ,  $b$  and  $q$  are constants. The function  $fg$  is such that  $fg(x) = 6x^2 - 21$  for  $x \leq q$ .  
 (i) Find the values of  $a$  and  $b$ .

(ii) Find the greatest possible value of  $q$ .

It is now given that  $q = -3$ .

(iii) Find the range of  $fg$ .

(iv) Find an expression for  $(fg)^{-1}(x)$  and state the domain of  $(fg)^{-1}$ .

[J16/P13/Q10]

62. The functions  $f$  and  $g$  are defined by

$$f(x) = \frac{4}{x} - 2 \quad \text{for } x > 0,$$

$$g(x) = \frac{4}{5x+2} \quad \text{for } x \geq 0.$$

(i) Find and simplify an expression for  $fg(x)$  and state the range of  $fg$ .

(ii) Find an expression for  $g^{-1}(x)$  and find the domain of  $g^{-1}$ .

[N16/P11/Q8]

63. A function  $f$  is defined by  $f: x \mapsto 5 - 2\sin 2x$  for  $0 \leq x \leq \pi$ .

(i) Find the range of  $f$ .

(ii) Sketch the graph of  $y = f(x)$ .

(iii) Solve the equation  $f(x) = 6$ , giving answers in terms of  $\pi$ .

The function  $g$  is defined by  $g: x \mapsto 5 - 2\sin 2x$  for  $0 \leq x \leq k$ , where  $k$  is a constant.

(iv) State the largest value of  $k$  for which  $g$  has an inverse.

(v) For this value of  $k$ , find an expression for  $g^{-1}(x)$ .

[N16/P12/Q10]

64. (i) Express  $4x^2 + 12x + 10$  in the form  $(ax+b)^2 + c$ , where  $a$ ,  $b$  and  $c$  are constants.

(ii) Functions  $f$  and  $g$  are both defined for  $x > 0$ . It is given that  $f(x) = x^2 + 1$  and  $fg(x) = 4x^2 + 12x + 10$ . Find  $g(x)$ .

(iii) Find  $(fg)^{-1}(x)$  and give the domain of  $(fg)^{-1}$ .

[N16/P13/Q8]

## ANSWERS

### Topic 2 - Functions and Graphs

1. (i)  $x < -3, x > 5.$

(ii)  $f(x) \geq -1$

No.  $f(x)$  is not a one-one function.

(iii)  $gf(x) = 0$

$$\Rightarrow 2x^2 - 4x + 3 = 0$$

$$\text{Discriminant} = (-4)^2 - 4(2)(3) \\ = -8 (< 0)$$

$\therefore$  No real solution.

(iv)

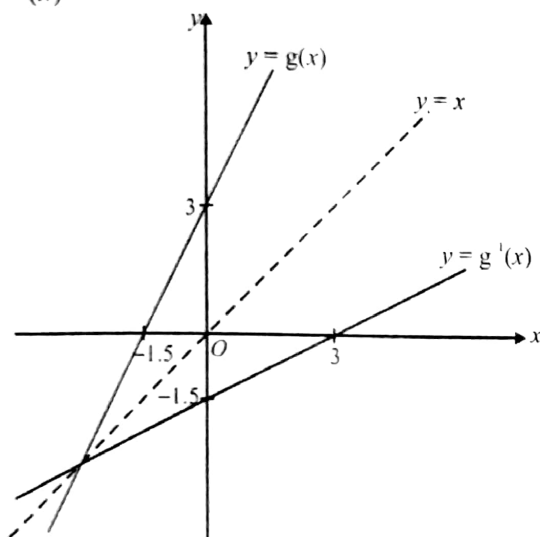

The graph of  $g^{-1}(x)$  is a reflection of graph of  $g(x)$  in the line  $y = x$ .

2. (i)  $x = 5.$

(ii)  $f(x) = g(x)$

$$\Rightarrow x^2 - 8x + a = 0$$

$$\text{Apply } b^2 - 4ac = 0$$

$$\Rightarrow a = 16.$$

(iii)  $(x-3)^2 - 9$

(iv)  $h^{-1}(x) = 3 + \sqrt{x+9}$

Domain of  $h^{-1}$ :  $x \geq -9.$

3. (i)  $1 \leq f(x) \leq 5.$

(ii)

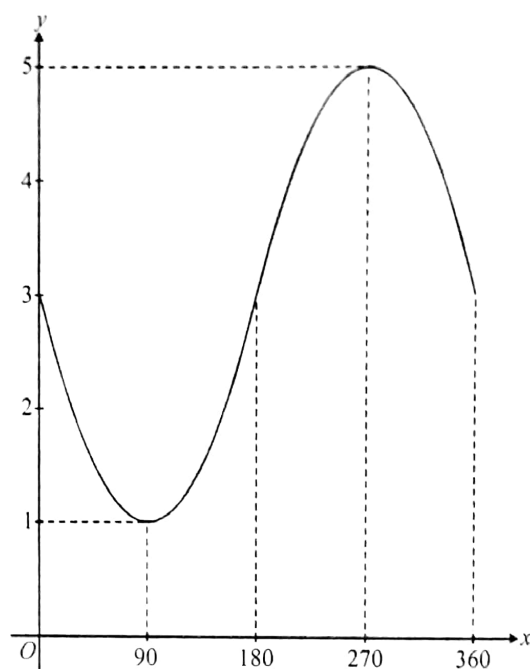

(iii)  $A = 90^\circ.$

(iv)  $g^{-1}(x) = \sin^{-1}\left(\frac{3-x}{2}\right).$

4. (i)  $f'(x) = 6(2x-3)^2$

Since  $f'(x)$  is a perfect square,

$\Rightarrow f'(x) > 0$  for all values of  $x$ .

Hence  $f(x)$  is an increasing function.

(ii)  $f^{-1}(x) = \frac{\sqrt[3]{x+8} + 3}{2}$

Domain of  $f^{-1}(x)$  is:  $-7 \leq x \leq 117.$

5. (i)  $f(x) = g(x)$

$$\Rightarrow -x^2 + (k-2)x + (2k-9) = 0$$

$$\text{Apply } b^2 - 4ac = 0$$

$$\Rightarrow k = -8, k = 4.$$

when  $k = -8, x = -5$

when  $k = 4, x = 1.$



(ii)  $x = 7$ .

(iii)  $g^{-1}(x) = \frac{9-2x}{x}, x \neq 0$ .

6. (i)  $x < -1$  and  $x > 4$

(ii)  $\left(x - \frac{3}{2}\right)^2 - \frac{9}{4}, a = \frac{3}{2}, b = \frac{9}{4}$

(iii)  $f(x) \geq -2.25$ .

(iv) No inverse.  $f(x)$  is not a one-one function.

(v)  $x = 25$ .

7. (i)  $f'(x) = \frac{-12}{(2x+3)^2}$   
 $\Rightarrow f'(x)$  is -ve for all values of  $x$ .  
 Thus  $f(x)$  is a decreasing function

(ii)  $f^{-1}(x) = \frac{6-3x}{2x}, x \neq 0$ .

Domain of  $f^{-1}(x)$ :  $0 < x \leq 2$

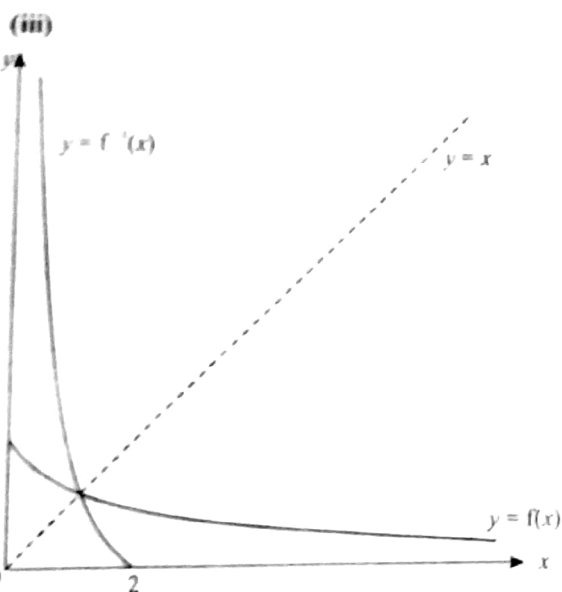

$y = f^{-1}(x)$  is the reflection of  $y = f(x)$  in the line  $y = x$ .

(iv)  $x = 1$ .

8. (i)  $f(x) = 2(x-2)^2 + 3$

(ii)  $f(x) \geq 3$

(iii) Because it is many-one function.

(iv)  $A = 2$ .

(v)  $g^{-1}(x) = 2 - \sqrt{\frac{x-3}{2}}$

Range of  $g^{-1}(x)$ :  $g^{-1}(x) \leq 2$ .

9. (i)  $f'(x) = 9(3x+2)^2$

As  $f'(x)$  is a perfect square,

$\Rightarrow f'(x) > 0$  for all values of  $x$

Hence  $f(x)$  is an increasing function.

(ii)  $f^{-1}(x) = \frac{\sqrt[3]{x+5} - 2}{3}$

Domain of  $f^{-1}(x)$ :  $x \geq 3$ .

10. (i)  $fg(x) = \frac{36}{2-x} - 2k$

given,  $fg(x) = x$

$\Rightarrow \frac{36}{2-x} - 2k = x$

$\Rightarrow x^2 + (2k-2)x + (36-4k) = 0$

Apply  $b^2 - 4ac = 0$

$\Rightarrow (2k-2)^2 - 4(1)(36-4k) = 0$

$\Rightarrow k = -7$ , or  $k = 5$

(ii) When  $k = 5$ ,  $x = -4$

When  $x = -7$ ,  $x = 8$ .

11. (i)

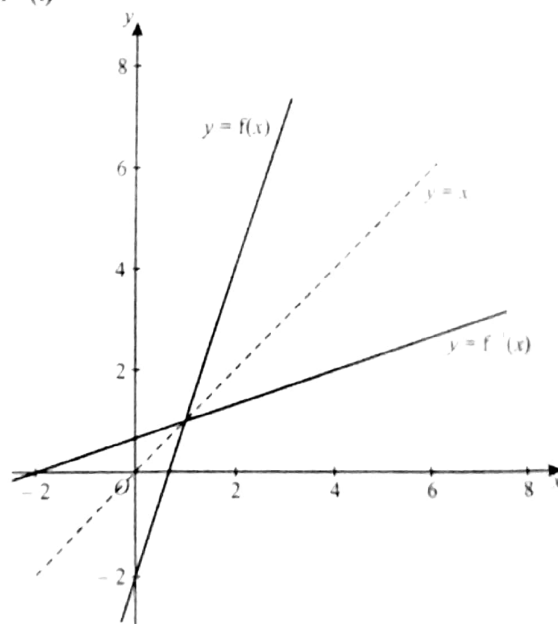

$y = f^{-1}(x)$  is the reflection of  $y = f(x)$  in the line  $y = x$ .

(ii)  $gf(x) = 6(3x-2) - (3x-2)^2$   
 $= -9x^2 + 30x - 16$   
 $= -(3x-5)^2 + 9$

$\therefore$  maximum value of  $gf(x) = 9$ .

(iii)  $h(x) = 9 - (x-3)^2$ .

(iv)  $h^{-1}(x) = 3 + \sqrt{9-x}$ .

12. (i)  $f(x) = 2(x-3)^2 - 5$   
 (ii)  $A = 6$ .  
 (iii) Range of  $f(x)$ :  $-5 \leq f(x) \leq 13$ .  
 (iv) Because  $g(x)$  is a one-one function.  
 (v)  $g^{-1}(x) = 3 + \sqrt{\frac{x+5}{2}}$ .

13. (i)  $gf(x) = x$   
 $\Rightarrow \frac{2(2x+1)-1}{(2x+1)+3} = x$   
 $\Rightarrow 2x^2 = 1 \Rightarrow x = \frac{1}{\sqrt{2}}$ .  
 (ii)  $f^{-1}(x) = \frac{x-1}{2}$ ,  $g^{-1}(x) = \frac{1+3x}{2-x}$ ,  $x \neq 2$ .  
 (iii)  $\frac{1+3x}{2-x} = x$   
 $\Rightarrow x^2 + x + 1 = 0$   
 Discriminant =  $-3 (< 0)$   
 $\therefore$  No real solution.

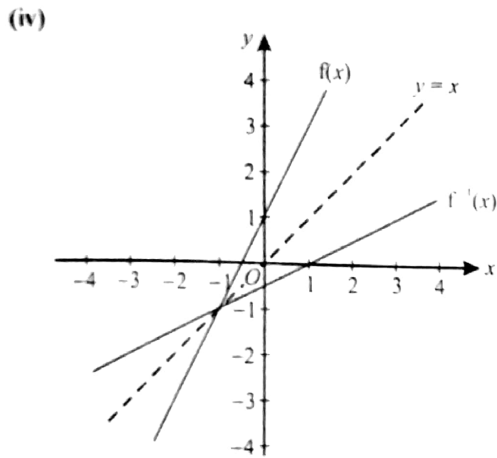

14. (i)  $2 \leq f(x) \leq 8$   
 (ii)
- 
- (iii)  $f(x)$  does not have an inverse because it is not a (1-1) function.

15. (i)  $f'(x) = \frac{-6}{(2x+5)^2}$   
 Since  $f'(x) < 0$  for all values of  $x$ ,  
 therefore  $f(x)$  is a decreasing function.  
 (ii)  $f^{-1}(x) = \frac{3-5x}{2x}$ ,  $x \neq 0$ .

16. (i)  $f(x) = 2 - 5\cos^2 x$   
 $a = 2$ ,  $b = -5$ .  
 (ii) Greatest = 2, Least =  $-3$ .  
 (iii)  $f(x) + 1 = 0$   
 $\Rightarrow 2 - 5\cos^2 x + 1 = 0$   
 $\Rightarrow \cos^2 x = \frac{3}{5}$   
 $\therefore x = 0.685, 2.46$ .

17. (i)  $f(x) = 2(x-3)^2 - 11$ .  
 (ii) Range of  $f(x)$ :  $f(x) \geq -11$ .  
 (iii)  $2(x-3)^2 - 11 < 21$   
 $\Rightarrow (x-3)^2 - 16 < 0 \Rightarrow (x+1)(x-7) < 0$   
 $\therefore -1 < x < 7$ .  
 (iv)  $gf(x) = 0$   
 $\Rightarrow 4x^2 - 24x + 14 + k = 0$   
 Apply  $b^2 - 4ac = 0$   
 $\Rightarrow 24^2 - 16(14+k) = 0 \Rightarrow k = 22$ .

18. (i)  $f(x) \leq 2$ .  
 (ii)  $gf(x) = k$   
 $\Rightarrow 20x - 10x^2 + 3 = k$   
 Apply,  $b^2 - 4ac = 0 \Rightarrow k = 13$ .

19. (i)  $a + b = 10$ ,  $a - \frac{1}{2}b = 1$   
 solving simultaneously gives,  $a = 4$ ,  $b = 6$ .  
 (ii) Range:  $-2 \leq f(x) \leq 10$   
 (iii)  $4 - 3\sqrt{3}$   
 20. (i) Substitute line into curve.  
 Then apply  $b^2 - 4ac = 0 \Rightarrow k = 4$  or  $12$   
 (ii)  $2(x-2)^2 + 6$ .  
 (iii) Range:  $f(x) \geq 6$   
 (iv)  $A = 2$ .

(v)  $g^{-1}(x) = 2 + \sqrt{\frac{x-6}{2}}$



21.  $gf(x) = (2x+3)^2 - 2(2x+3)$   
 $= 4x^2 + 8x + 3 = 4(x+1)^2 - 1$

22. (i)  $f(x) \leq 3$

(ii)  $3 - 2\sqrt{3}$

(iii)

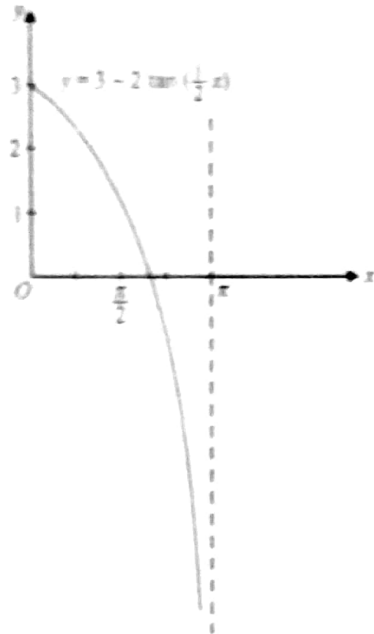

(iv)  $f^{-1}(x) = 2 \tan^{-1}\left(\frac{3-x}{2}\right)$

23. (i)  $f(x) = (x-2)^2 + 3$ , Range:  $f(x) \geq 3$ .

(ii)  $f^{-1}(x) = 2 + \sqrt{x-3}$

Domain of  $f^{-1}(x)$ :  $x > 3$ .

(iii)  $f = hg$

$\Rightarrow h = fg^{-1}$

$\Rightarrow h(x) = x^2 + 3$

24. (i) Range:  $0 \leq f(x) \leq 2$ ,  $2 < f(x) \leq 4$

(ii)

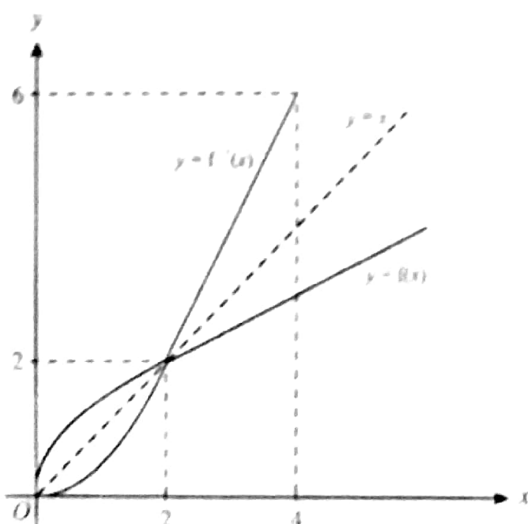

(iii)  $f^{-1}(x) = \sqrt{2x}$  for  $0 \leq x \leq 2$

$f^{-1}(x) = 2(x-1)$  for  $2 < x \leq 4$

25. (i)  $fg(x) = 2x^2 - 3$

$fg(x) = 4x^2 + 4x - 1$

(ii)  $a = -1$

(iii)  $b = 2$

(iv)  $f^{-1}(x) = \frac{1}{2}(x-1)$

$f^{-1}g(x) = \frac{1}{2}(x^2 - 3)$

(v)  $h^{-1}(x) = -\sqrt{x+2}$

26. (i)  $f(x) = \frac{x+3}{2x-1}$

$ff(x) = \frac{\frac{x+3}{2x-1} + 3}{2\left(\frac{x+3}{2x-1}\right) - 1}$

$= \frac{x+3+6x-3}{2x+6-2x+1} = \frac{7x}{7} = x$

(ii) Since  $ff(x) = x$

$\Rightarrow f(x) = f^{-1}(x)$

Hence,  $f^{-1}(x) = \frac{x+3}{2x-1}$

27. (i)  $fg(2) = 26$

(ii)

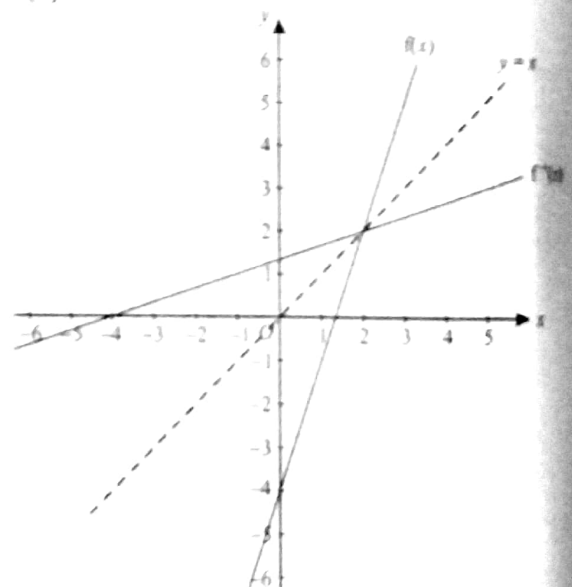

(iii)  $g'(x) = 6(x-1)^2$

Turning points of  $g(x)$  does not lie in the given domain.

Therefore  $g(x)$  is a 1-1 function and has an inverse.



(iv)  $f^{-1}(x) = \frac{x+4}{3}$ ,  $g^{-1}(x) = 1 + \sqrt{\frac{x-8}{2}}$

28. (i)  $f(x) = 2(x-2)^2 + 2$

(ii)  $2 \leq f(x) \leq 10$ .

(iii) Domain of  $f^{-1}(x)$ :  $2 \leq x \leq 10$ .

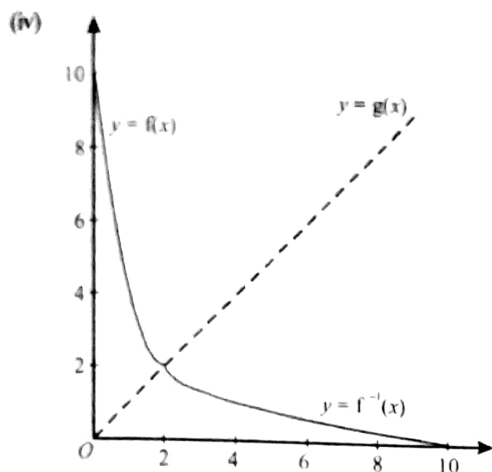

(v)  $f^{-1}(x) = 2 - \sqrt{\frac{x-2}{2}}$

29. (i)  $a = -2$ ,  $b = 8$

(ii)  $fg(x) = 3(8 - 2x) - 2$   
 $= 22 - 6x$

30. (i)  $f^{-1}(x) = \frac{x-3}{2}$ ,

$f(x) = f^{-1}(x)$

$\Rightarrow 2x+3 = \frac{x-3}{2} \Rightarrow x = -3$ .

(ii)

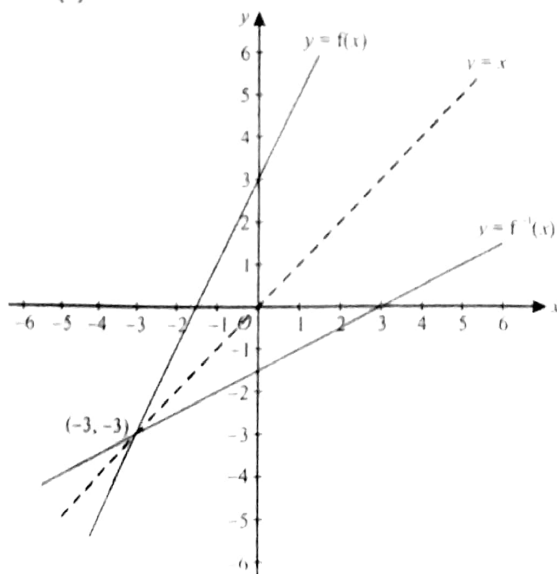

(iii)  $gf(x) \leq 16$

$(2x+3)^2 - 6(2x+3) \leq 16$

$\Rightarrow 4x^2 - 9 \leq 16 \Rightarrow x^2 \leq \frac{25}{4}$

$\therefore -\frac{5}{2} \leq x \leq 0$ .

31. (i)  $f(x) = (x-2)^2 - 4 + k$

(ii)  $f(x) > -4 + k$

(iii)  $p = 2$

(iv)  $f^{-1}(x) = 2 + \sqrt{x-k+4}$

Domain of  $f^{-1}(x)$ :  $x \geq k-4$

32. (i)  $f^{-1}(x) = \frac{x-5}{2}$

$g^{-1}(x) = \frac{8+3x}{x}$ ,  $x \in \mathbb{R}$ ,  $x \neq 0$

(ii)

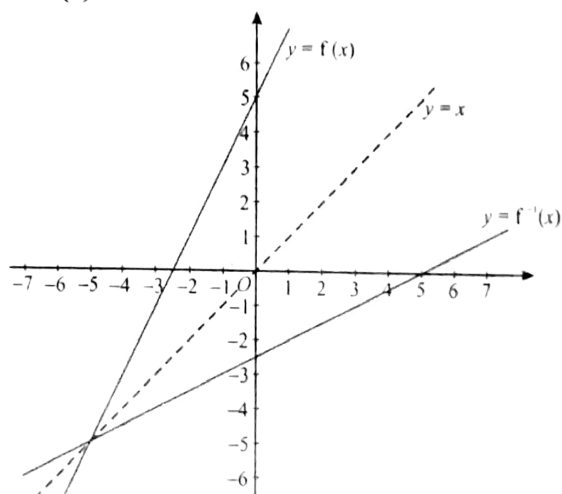

$y = f^{-1}(x)$  is the reflection of  $y = f(x)$  in the line  $y = x$ .

(iii)  $fg(x) = 5 - kx$

$\Rightarrow 2\left(\frac{8}{x-3}\right) + 5 = 5 - kx$

$\Rightarrow kx^2 - 3kx + 16 = 0$

apply  $b^2 - 4ac < 0$

$\therefore 0 < k < \frac{64}{9}$

33. (i) Stationary point, (2, 8),

Nature: maximum.

(ii)  $k = 2$ .

(iii)  $g^{-1}(x) = 2 + \sqrt{8-x}$

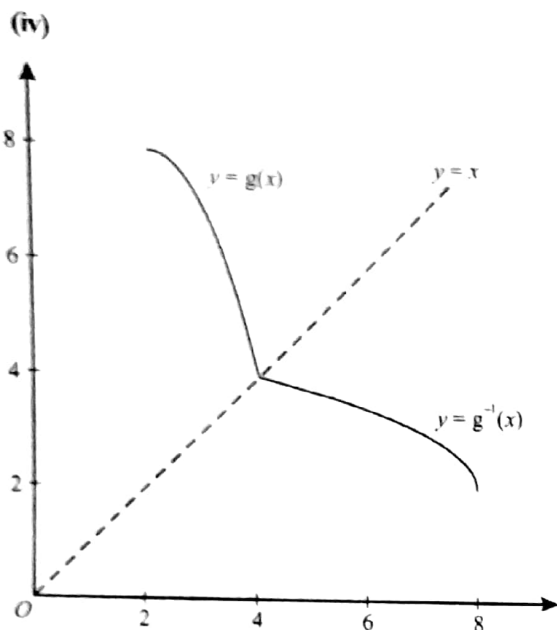

34. (i)  $f(x) = 4(x-3)^2 - 25$   
coordinates of vertex : (3, -25).

(ii) Range :  $g(x) \geq -9$ .

(iii)  $g^{-1}(x) = \frac{1}{2}[6 - \sqrt{x+25}]$

Domain is :  $x \geq -9$ .

35. (i)  $f^{-1}(x) = 2x^2 - 4x - 1$

(ii) Domain of  $f^{-1}(x)$  :  $x \geq 1$ .

36. (i)  $gf(x) = 1$

$\Rightarrow \cos(\frac{1}{2}x + \frac{1}{6}\pi) = 1 \Rightarrow x = -\frac{\pi}{3}$

(ii)  $fg(x) = 1$

$\Rightarrow \frac{1}{2}\cos x + \frac{1}{6}\pi = 1 \Rightarrow x = \pm 0.31$ .

37. (i)  $p = 3, q = 2$ .

(ii)  $f^{-1}(x) = \begin{cases} \sqrt{11-x} & 2 \leq x \leq 11, \\ 5-x & x < 2. \end{cases}$

38. (i)  $2(x-3)^2 - 5$ .

(ii)  $k = 3$ .

(iii) Range of  $f$  :  $f(x) \geq 27$ .

(iv)  $f^{-1}(x) = 3 + \sqrt{\frac{x+5}{2}}$ ,

Domain of  $f^{-1}$  :  $x \geq 27$ .

39. (i)  $f'(x) = \frac{15}{(1-3x)^2}$

(ii)  $f'(x) = \frac{15}{(1-3x)^2}$

$(1-3x)^2$  is a perfect square.

$\Rightarrow f'(x) > 0$  for all values of  $x$ .

Thus,  $f(x)$  is an increasing function.

(iii)  $f^{-1}(x) = \frac{x-5}{3x}, x \neq 0$

Domain of  $f^{-1}(x)$  :  $-2.5 \leq x < 0$

Range of  $f^{-1}(x)$  :  $f^{-1}(x) \geq 1$ .

40. (i)  $ff(x) = 25$

$\Rightarrow 2(2x+3)+3 = 25 \Rightarrow x = 4$

(ii)  $f(x) = g(x)$

$\Rightarrow x^2 - 6x + 8 = 2x + k$

$\Rightarrow x^2 - 8x + 8 - k = 0$

Use  $b^2 - 4ac < 0$

$\Rightarrow 64 - 4(8-k) < 0 \Rightarrow k < -8$ .

(iii)  $h^{-1}(x) = 3 + \sqrt{x+1}$ .

41. (i)  $f^{-1} : x \mapsto \sqrt{x-1}$  for  $x > 1$ .

(ii)  $ff(x) = \frac{185}{16}$

$\Rightarrow f(x) = f^{-1}(\frac{185}{16}) \Rightarrow f(x) = \sqrt{\frac{169}{16}} = \frac{13}{4}$

$x = f^{-1}(\frac{13}{4}) \Rightarrow x = \sqrt{\frac{9}{4}} = \frac{3}{2}$

42. (i)  $x = 0.841, 5.44$  radians.

(ii)  $-5 \leq f(x) \leq 1$

(iii)

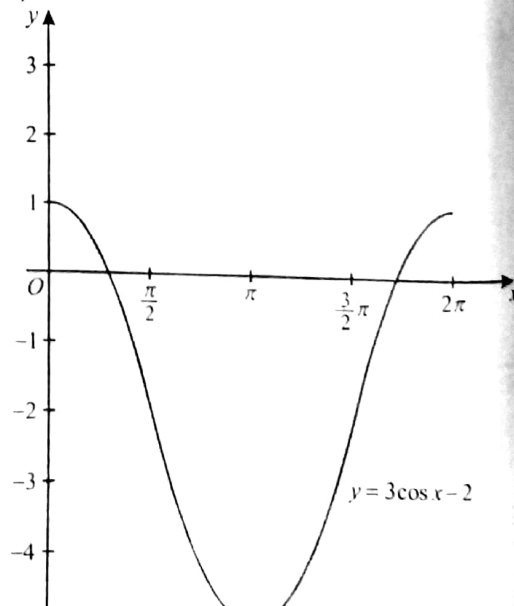

(v)  $k = \pi$

(v)  $g^{-1}(x) = \cos^{-1}\left(\frac{x+2}{3}\right)$

43. (i) Range of  $f$ :  $f(x) \geq c^2 + 4c$

$f(x) = x^2 + 4x$

$= (x+2)^2 - 4$

$\therefore$  smallest value of  $c = -2$

(ii)  $5a + b = 11$  .....(1)

$(a+b)^2 + 4(a+b) = 21$  .....(2)

solving simultaneously gives,

$a = \frac{9}{2}$  or  $a = 2$

$b = -\frac{23}{2}$  or  $b = 1$

44. (i)  $-5 \leq f(x) \leq 4$ .

(ii)

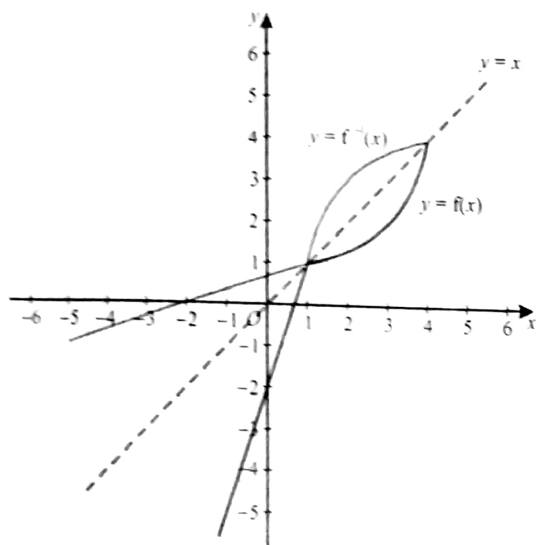

(iii)  $f^{-1}(x) = \begin{cases} \frac{x+2}{3} & \text{for } -5 \leq x \leq 1 \\ \frac{5x-4}{x} & \text{for } 1 < x \leq 4 \end{cases}$

45. (i)  $ff(x) = 11$

$\Rightarrow 2(2x-3) - 3 = 11 \Rightarrow x = 5$

(ii) Range:  $g(x) \geq -4$ .

(iii)  $x < -6, x > 2$ .

(iv)  $gf(x) = p$

$\Rightarrow 4x^2 - 4x - (p+3) = 0$

use  $b^2 - 4ac = 0$

$\Rightarrow p = -4$ .

(v)  $k = -2$ .

(vi)  $h^{-1}(x) = -2 + \sqrt{x+4}$ .

46. (i)  $f'(x) = \frac{-30}{(2x+3)^2}$

$f'(x) < 0$ ,

$\Rightarrow f(x)$  has no turning points.

Therefore  $f(x)$  is a 1-1 function and has an inverse.

(ii)  $f^{-1}(x) = \frac{15-3x}{2x}$

Domain:  $1 \leq x \leq 5$ .

Range:  $0 \leq f^{-1}(x) \leq 6$ .

47. (i)  $(x-1)^2 - 16$

(ii) Smallest  $c = -16$ .

(iii)  $c \leq f(x) \leq d$

$\Rightarrow 9 \leq (x-1)^2 - 16 \leq 65$

$\Rightarrow 6 \leq x \leq 10$

$p = 6, q = 10$ .

(iv)  $f^{-1}(x) = 1 + \sqrt{x+16}$

48. (i)  $x = \frac{2\pi}{3}$ .

(ii)  $2 \leq f(x) \leq 10$ .

(iii)

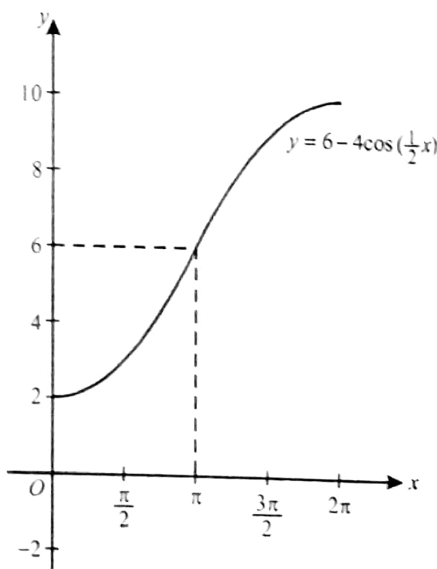

(iv)  $f^{-1}(x) = 2\cos^{-1}\left(\frac{6-x}{4}\right)$ .

49. (i)  $(a+b)^{\frac{1}{3}} = 2 \Rightarrow a+b = 8$   
 $(9a+b)^{\frac{2}{3}} = 16 \Rightarrow 9a+b = 64$   
 solved simultaneously gives,  
 $a = 7, b = 1.$

(ii)  $f^{-1}(x) = \frac{1}{7}(x^3 - 1)$   
 Domain of  $f^{-1}$ :  $x \geq 1$

50. (i)  $x = 1.68$  radians.

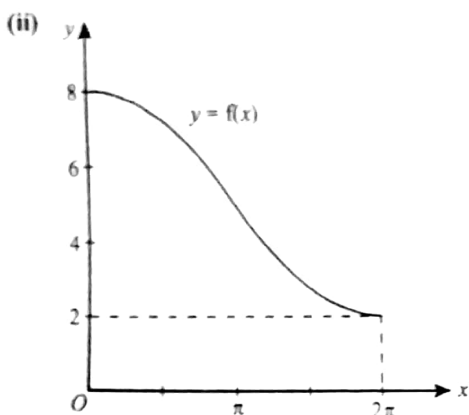

(iii) For the given domain,  $f(x)$  is a one-one function and so has an inverse.

(iv)  $f^{-1}(x) = 2 \cos^{-1}\left(\frac{x-5}{3}\right)$

51. (i)  $f(x) = p$   
 $\Rightarrow 2x^2 - 6x + 5 - p = 0$   
 Apply Discriminant  $< 0$   
 $\Rightarrow p < \frac{1}{2}$

(ii)  $g(x) = 2\left(x - \frac{3}{2}\right)^2 + \frac{1}{2}$

(iii)  $\frac{1}{2} \leq g(x) \leq 13.$

(iv)  $k = \frac{3}{2}.$

(v)  $h^{-1}(x) = \frac{3 + \sqrt{2x-1}}{2}$

52. (i)  $f(x) = \frac{1}{2x+5}$   
 Domain of  $f(x)$ :  $x \geq -\frac{9}{4}$

(ii)  $f^{-1}g(x) = \frac{1 - 5\left(\frac{1}{x}\right)}{2\left(\frac{1}{x}\right)}$   
 $= \frac{x-5}{2}$

53. (i)  $-(x-3)^2 + 4$

(ii) smallest value of  $m = 3$

(iii)  $f^{-1}(x) = 3 + \sqrt{4-x}$ . Domain:  $x \leq 0.$

54.  $f^{-1}(x) = gf(x)$   
 $\Rightarrow \frac{x-2}{3} = 4(3x+2) - 12 \Rightarrow x = \frac{2}{7}$

55. (i)  $f(x) = x^2 + 6x - 8$   
 $= (x+3)^2 - 17$   
 $\therefore$  Range of  $f$ :  $f(x) \geq -17$

(ii)  $a = 5$ , and  $f(x) = 0$  gives,  $x^2 + 5x + b = 0$   
 given roots are:  $x = k$  and  $x = -2k$   
 $\Rightarrow x^2 + 5x + b \equiv (x-k)(x+2k)$   
 $\Rightarrow x^2 + 5x + b \equiv x^2 + kx - 2k^2$   
 $\therefore$  by comparison,  $k = 5, b = -50$

(iii)  $f(x+a) = a$   
 $\Rightarrow (x+a)^2 + a(x+a) + b = a$   
 $\Rightarrow x^2 + 3ax + (2a^2 + b - a) = 0$   
 Using  $b^2 - 4ac < 0$  gives,  
 $a^2 < 4(b-a)$

56. (i)  $3(x-1)^2 - 1$

(ii)  $f'(x) = 3x^2 - 6x + 7$   
 $= 3(x-1)^2 + 4$   
 As  $f'(x) > 0$  for all values of  $x$ ,  
 $\Rightarrow f(x)$  is an increasing function.

57. (i)  $g(x)$  is defined for  $x \leq -1$ ,  
 and  $f(x) = 3x + 1$   
 $\Rightarrow 3x + 1 \leq -1 \Rightarrow x \leq -\frac{2}{3}$   
 $\therefore$  largest value of  $a = -\frac{2}{3}$

(ii)  $fg(x) + 14 = 0$   
 $\Rightarrow 3(-1-x^2) + 1 + 14 = 0$   
 $\Rightarrow x^2 = 4 \Rightarrow x = \pm 2 \Rightarrow x = -2.$

(iii)  $gf(x) \leq -50$   
 $\Rightarrow -1 - (3x+1)^2 \leq -50 \Rightarrow x \leq -\frac{8}{3}$

58. (i)  $-5 \leq f(x) \leq 3$

(ii) (0, -1) and (0.253, 0)

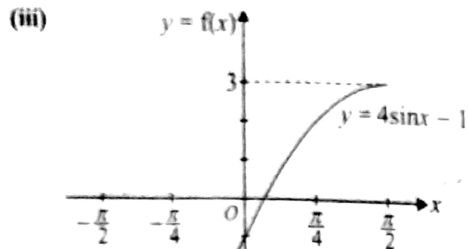

(iv)  $f^{-1}(x) = \sin^{-1}\left(\frac{x+1}{4}\right)$

Domain of  $f^{-1}(x)$ :  $-5 \leq x \leq 3$

Range of  $f^{-1}(x)$ :  $-\frac{1}{2}\pi \leq f^{-1}(x) \leq \frac{1}{2}\pi$ .

59.  $ff(x) = -20 + 9x$ ,  $gf(2) = -2$

$\Rightarrow -20 + 9x = -2 \Rightarrow x = 2$

60. (i)  $f(x) \leq 3$

$\Rightarrow 6x - x^2 - 5 \leq 3$

$\Rightarrow (x-4)(x-2) \geq 0 \Rightarrow x \leq 2, x \geq 4$

(ii) Eliminating  $y$ , we have,

$\Rightarrow 6x - x^2 - 5 = mx + c$

$\Rightarrow x^2 + (m-6)x + (c+5) = 0$

Use, Disc. = 0,  $\Rightarrow 4c = m^2 - 12m + 16$

(iii)  $4 - (x-3)^2$

(iv) The smallest value of  $k = 3$ .

(v)  $g^{-1}(x) = 3 + \sqrt{4-x}$

61. (i)  $fg(x) = 2(ax^2 + b) + 3$

$= 2ax^2 + 2b + 3$

by comparison with  $fg(x) = 6x^2 - 21$

$2a = 6 \Rightarrow a = 3$

$2b + 3 = -21 \Rightarrow b = -12$

(ii)  $f(x)$  is defined for  $x \geq 0$ ,

Subst.  $a$  and  $b$  into  $g$  gives,  $g(x) = 3x^2 - 12$

$\Rightarrow 3x^2 - 12 \geq 0$

$\Rightarrow (x+2)(x-2) \geq 0 \Rightarrow x \leq -2, x \geq 2$

$\therefore$  max. value of  $q = -2$

(iii) Range of  $fg$ :  $fg(x) \geq 33$

(iv)  $(fg)^{-1}(x) = -\sqrt{\frac{x+21}{6}}$ , Domain is:  $x \geq 33$

62. (i)  $fg(x) = \frac{4}{4} - 2 = 5x$

Range of  $fg(x)$ :  $fg(x) \geq 0$

(ii)  $g^{-1}(x) = \frac{4-2x}{5x}$

Domain of  $g^{-1}(x)$ :  $0 < x \leq 2$

63. (i) Range of  $f$ :  $3 \leq f(x) \leq 7$

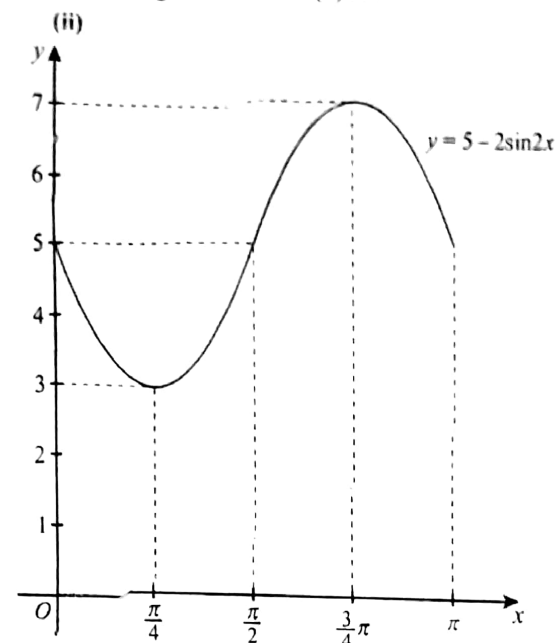

(iii)  $5 - 2\sin 2x = 6 \Rightarrow \sin 2x = -\frac{1}{2}$

$\Rightarrow 2x = \frac{7}{6}\pi, \frac{11}{6}\pi \Rightarrow x = \frac{7}{12}\pi, \frac{11}{12}\pi$

(iv) From graph,  $k = \frac{\pi}{4}$

(v)  $g^{-1}(x) = \frac{1}{2}\sin^{-1}\left(\frac{5-x}{2}\right)$

64. (i)  $(2x+3)^2 + 1$

(ii)  $g(x) = 2x+3$

(iii)  $(fg)^{-1}(x) = \frac{1}{2}\sqrt{x-1} - \frac{3}{2}$

Domain of  $(fg)^{-1}$ :  $x > 10$

2/8/17

Rest OK

Only Q. Numbers

A

### TOPIC 3

## Coordinate Geometry

5. The curve  $y^2 = 12x$  intersects the line  $3y = 4x + 6$  at two points. Find the distance between the two points. [J06/P12/Q5]

6.

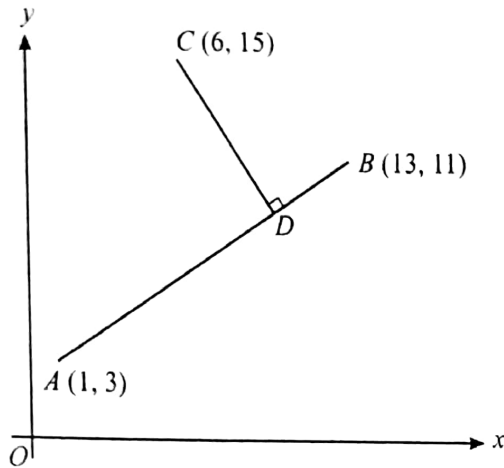

The three points  $A(1, 3)$ ,  $B(13, 11)$  and  $C(6, 15)$  are shown in the diagram. The perpendicular from  $C$  to  $AB$  meets  $AB$  at the point  $D$ . Find

- (i) the equation of  $CD$ ,
- (ii) the coordinates of  $D$ .

[N06/P12/Q5]

7.

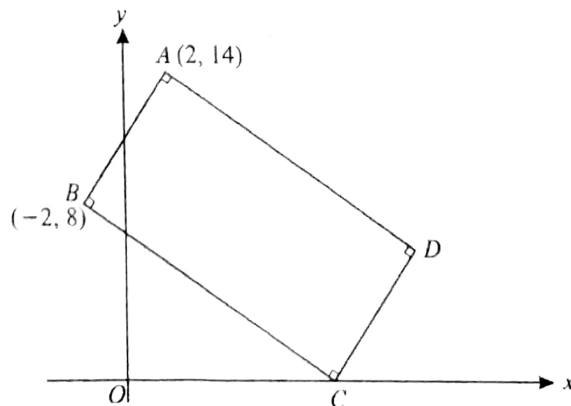

The diagram shows a rectangle  $ABCD$ . The point  $A$  is  $(2, 14)$ ,  $B$  is  $(-2, 8)$  and  $C$  lies on the  $x$ -axis. Find

- (i) the equation of  $BC$ ,
- (ii) the coordinates of  $C$  and  $D$ .

[J07/P12/Q6]



8. The three points  $A(3, 8)$ ,  $B(6, 2)$  and  $C(10, 2)$  are shown in the diagram. The point  $D$  is such that the line  $DA$  is perpendicular to  $AB$  and  $DC$  is parallel to  $AB$ . Calculate the coordinates of  $D$ .

[N07/P12/Q6]

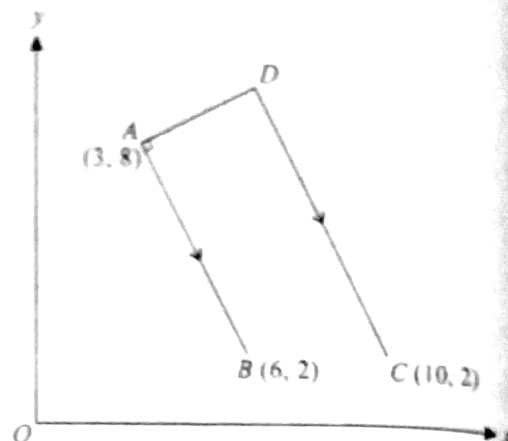

9.

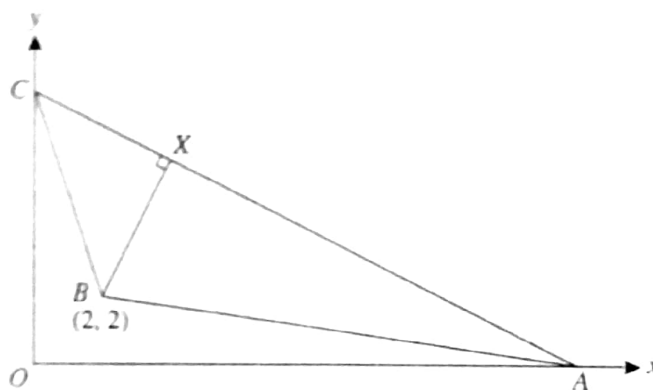

In the diagram, the points  $A$  and  $C$  lie on the  $x$ - and  $y$ -axes respectively and the equation of  $AC$  is  $2y + x = 16$ . The point  $B$  has coordinates  $(2, 2)$ . The perpendicular from  $B$  to  $AC$  meets  $AC$  at the point  $X$ .

- (i) Find the coordinates of  $X$ .

The point  $D$  is such that the quadrilateral  $ABCD$  has  $AC$  as a line of symmetry.

- (ii) Find the coordinates of  $D$ .  
 (iii) Find, correct to 1 decimal place, the perimeter of  $ABCD$ .

[J08/P12/Q11]

10. The equation of a curve is  $y = 5 - \frac{8}{x}$ .

- (i) Show that the equation of the normal to the curve at the point  $P(2, 1)$  is  $2y + x = 4$ .  
 This normal meets the curve again at the point  $Q$ .

- (ii) Find the coordinates of  $Q$ .  
 (iii) Find the length of  $PQ$ .

[N08/P12/Q8]



11. The diagram shows points  $A$ ,  $B$  and  $C$  lying on the line  $2y = x + 4$ . The point  $A$  lies on the  $y$ -axis and  $AB = BC$ . The line from  $D(10, -3)$  to  $B$  is perpendicular to  $AC$ . Calculate the coordinates of  $B$  and  $C$ .

[J09/P12/Q8]

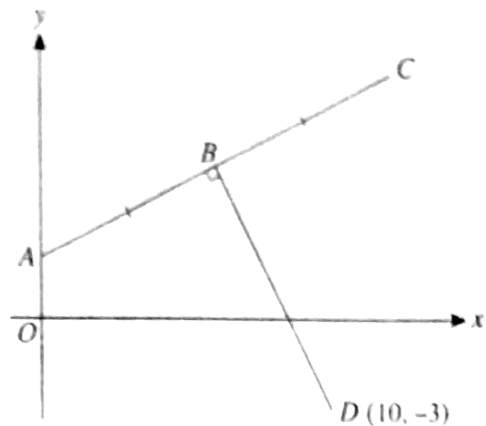

12. The diagram shows a rectangle  $ABCD$ . The point  $A$  is  $(0, -2)$  and  $C$  is  $(12, 14)$ . The diagonal  $BD$  is parallel to the  $x$ -axis.

- Explain why the  $y$ -coordinate of  $D$  is 6.  
The  $x$ -coordinate of  $D$  is  $h$ .
- Express the gradients of  $AD$  and  $CD$  in terms of  $h$ .
- Calculate the  $x$ -coordinates of  $D$  and  $B$ .
- Calculate the area of the rectangle  $ABCD$ .

[N09/P12/Q9]

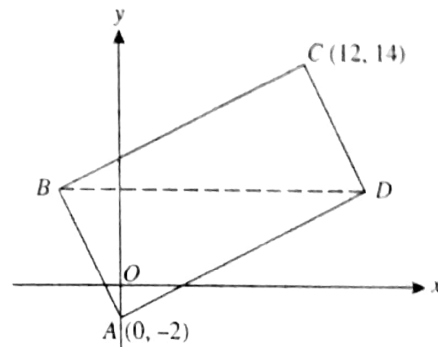

13. The diagram shows a triangle  $ABC$  in which  $A$  is  $(3, -2)$  and  $B$  is  $(15, 22)$ . The gradients of  $AB$ ,  $AC$  and  $BC$  are  $2m$ ,  $-2m$  and  $m$  respectively, where  $m$  is a positive constant.

- Find the gradient of  $AB$  and deduce the value of  $m$ .
- Find the coordinates of  $C$ .  
The perpendicular bisector of  $AB$  meets  $BC$  at  $D$ .
- Find the coordinates of  $D$ .

[J10/P11/Q8]

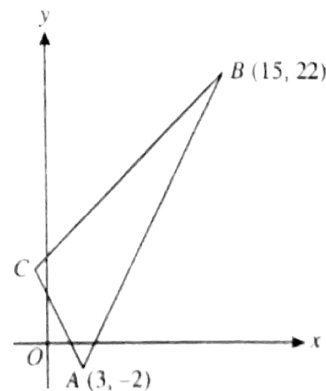

14. In the diagram,  $A$  is the point  $(-1, 3)$  and  $B$  is the point  $(3, 1)$ . The line  $L_1$  passes through  $A$  and is parallel to  $OB$ . The line  $L_2$  passes through  $B$  and is perpendicular to  $AB$ . The lines  $L_1$  and  $L_2$  meet at  $C$ . Find the coordinates of  $C$ .

[J10/P12/Q4]

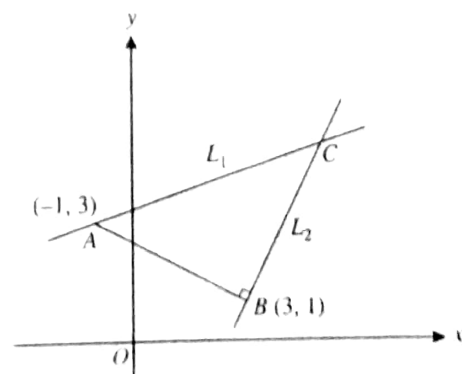

AL Mathematics (P1)

15. The diagram shows a rhombus  $ABCD$  in which the point  $A$  is  $(-1, 2)$ , the point  $C$  is  $(5, 4)$  and the point  $B$  lies on the  $y$ -axis. Find
- the equation of the perpendicular bisector of  $AC$ ,
  - the coordinates of  $B$  and  $D$ ,
  - the area of the rhombus. [J10/P13/Q8]

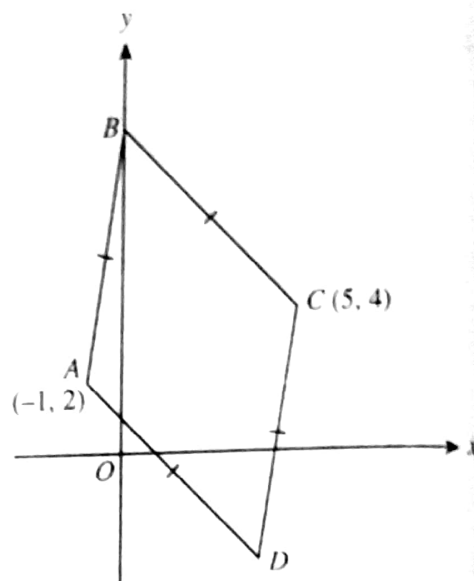

16. The diagram shows part of the curve  $y = \frac{2}{1-x}$  and the line  $y = 3x + 4$ . The curve and the line meet at points  $A$  and  $B$ .
- Find the coordinates of  $A$  and  $B$ .
  - Find the length of the line  $AB$  and the coordinates of the mid-point of  $AB$ .

[N10/P12/Q8]

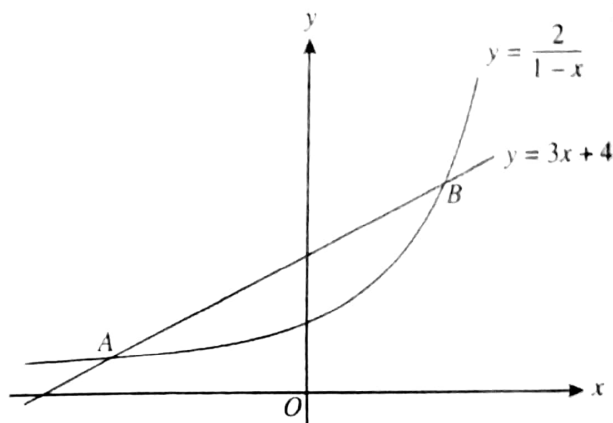

17. Points  $A$ ,  $B$  and  $C$  have coordinates  $(2, 5)$ ,  $(5, -1)$  and  $(8, 6)$  respectively.
- Find the coordinates of the mid-point of  $AB$ .
  - Find the equation of the line through  $C$  perpendicular to  $AB$ . Give your answer in the form  $ax + by + c = 0$ . [N10/P13/Q2]
18. The line  $x - y + 4 = 0$  intersects the curve  $y = 2x^2 - 4x + 1$  at points  $P$  and  $Q$ . It is given that the coordinates of  $P$  are  $(3, 7)$ .
- Find the coordinates of  $Q$ .
  - Find the equation of the line joining  $Q$  to the mid-point of  $AP$ . [J11/P11/Q10(ii),(iii)]
19. The line  $L_1$  passes through the points  $A(2, 5)$  and  $B(10, 9)$ . The line  $L_2$  is parallel to  $L_1$  and passes through the origin. The point  $C$  lies on  $L_2$  such that  $AC$  is perpendicular to  $L_2$ . Find
- the coordinates of  $C$ ,
  - the distance  $AC$ . [J11/P12/Q7]

20. The line  $\frac{x}{a} + \frac{y}{b} = 1$ , where  $a$  and  $b$  are positive constants, meets the  $x$ -axis at  $P$  and the  $y$ -axis at  $Q$ .

Given that  $PQ = \sqrt{45}$  and that the gradient of the line  $PQ$  is  $-\frac{1}{2}$  find the values of  $a$  and  $b$ .

[J11/P13/Q3]

21. The diagram shows a quadrilateral  $ABCD$  in which the point  $A$  is  $(-1, -1)$ , the point  $B$  is  $(3, 6)$  and the point  $C$  is  $(9, 4)$ . The diagonals  $AC$  and  $BD$  intersect at  $M$ . Angle  $BMA = 90^\circ$  and  $BM = MD$ .

Calculate

- (i) the coordinates of  $M$  and  $D$ ,  
 (ii) the ratio  $AM : MC$ .

[N11/P12/Q9]

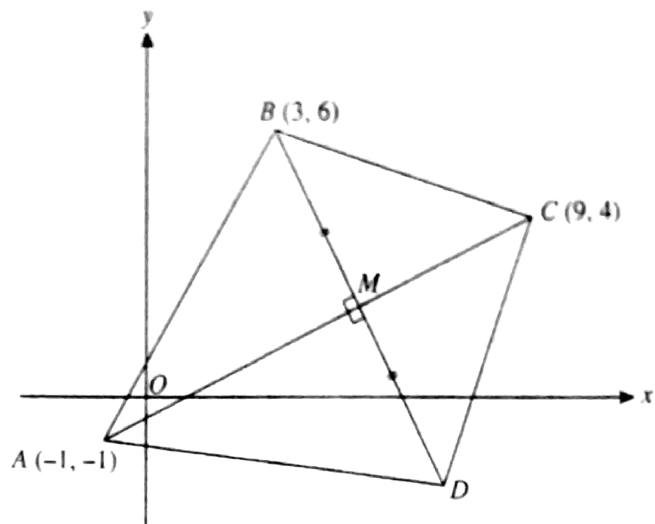

- 22.

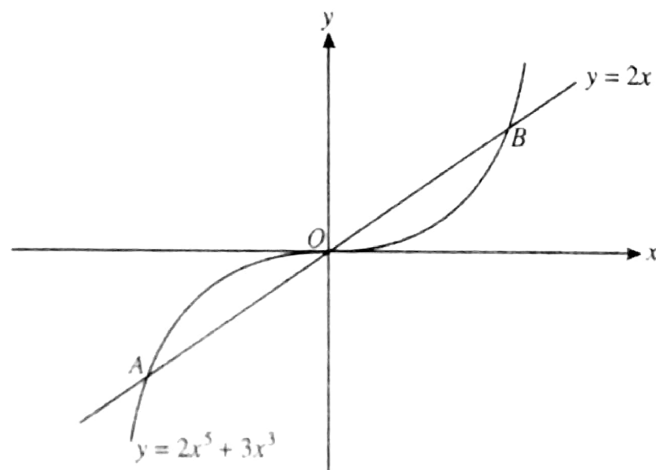

The diagram shows the curve  $y = 2x^5 + 3x^3$  and the line  $y = 2x$  intersecting at points  $A$ ,  $O$  and  $B$ .

- (i) Show that the  $x$ -coordinates of  $A$  and  $B$  satisfy the equation  $2x^4 + 3x^2 - 2 = 0$ .  
 (ii) Solve the equation  $2x^4 + 3x^2 - 2 = 0$  and hence find the coordinates of  $A$  and  $B$ , giving your answers in an exact form.

[N11/P13/Q3]

23. The coordinates of  $A$  are  $(-3, 2)$  and the coordinates of  $C$  are  $(5, 6)$ . The mid-point of  $AC$  is  $M$  and the perpendicular bisector of  $AC$  cuts the  $x$ -axis at  $B$ .

- (i) Find the equation of  $MB$  and the coordinates of  $B$ .  
 (ii) Show that  $AB$  is perpendicular to  $BC$ .  
 (iii) Given that  $ABCD$  is a square, find the coordinates of  $D$  and the length of  $AD$ .

[J12/P11/Q9]

24. The point  $A$  has coordinates  $(-1, -5)$  and the point  $B$  has coordinates  $(7, 1)$ . The perpendicular bisector of  $AB$  meets the  $x$ -axis at  $C$  and the  $y$ -axis at  $D$ . Calculate the length of  $CD$ . [J12/P12/Q4]

25. The diagram shows a triangle  $ABC$  in which  $A$  has coordinates  $(1, 3)$ ,  $B$  has coordinates  $(5, 11)$  and angle  $ABC$  is  $90^\circ$ . The point  $X(4, 4)$  lies on  $AC$ . Find

- (i) the equation of  $BC$ ,  
 (ii) the coordinates of  $C$ . [N12/P12/Q5]

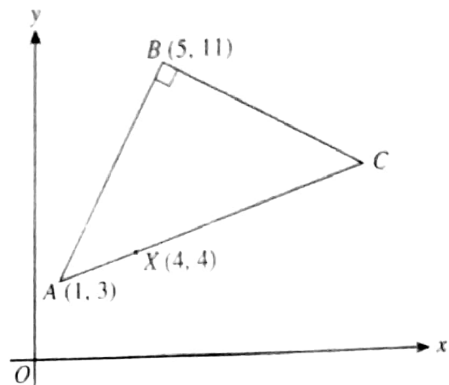

26. The point  $R$  is the reflection of the point  $(-1, 3)$  in the line  $3y + 2x = 33$ . Find by calculation the coordinates of  $R$ . [J13/P12/Q7]

27. The diagram shows the curve  $y = \sqrt{1+4x}$ , which intersects the  $x$ -axis at  $A$  and the  $y$ -axis at  $B$ . The normal to the curve at  $B$  meets the  $x$ -axis at  $C$ . Find

- (i) the equation of  $BC$ ,  
 (ii) the area of the shaded region.

[J13/P12/Q11]

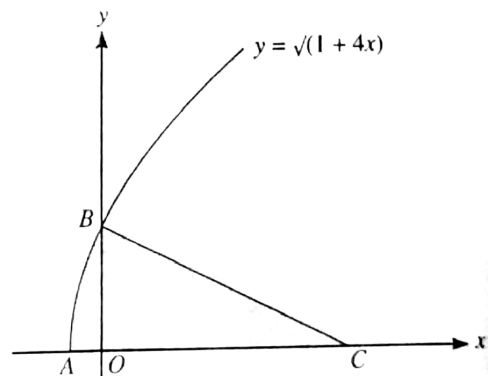

28. The diagram shows three points  $A(2, 14)$ ,  $B(14, 6)$  and  $C(7, 2)$ . The point  $X$  lies on  $AB$ , and  $CX$  is perpendicular to  $AB$ . Find, by calculation,

- (i) the coordinates of  $X$ ,

- (ii) the ratio  $AX:XB$ .

[J13/P13/Q7]

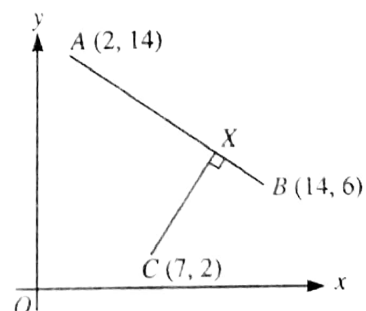

29. The point  $A$  has coordinates  $(-1, 6)$  and the point  $B$  has coordinates  $(7, 2)$ .
- (i) Find the equation of the perpendicular bisector of  $AB$ , giving your answer in the form  $y = mx + c$ .
- (ii) A point  $C$  on the perpendicular bisector has coordinates  $(p, q)$ . The distance  $OC$  is 2 units, where  $O$  is the origin. Write down two equations involving  $p$  and  $q$  and hence find the coordinates of the possible positions of  $C$ . [N13/P11/Q7]

30. The diagram shows a rectangle  $ABCD$  in which point  $A$  is  $(0, 8)$  and point  $B$  is  $(4, 0)$ . The diagonal  $AC$  has equation  $8y + x = 64$ . Find, by calculation, the coordinates of  $C$  and  $D$ .

[N13/P12/Q5]

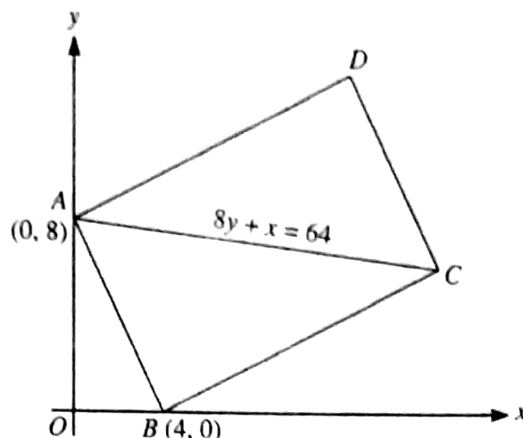

31. The point  $A$  has coordinates  $(3, 1)$  and the point  $B$  has coordinates  $(-21, 11)$ . The point  $C$  is the mid-point of  $AB$ .

- (i) Find the equation of the line through  $A$  that is perpendicular to  $y = 2x - 7$ .  
 (ii) Find the distance  $AC$ .

[N13/P13/Q3]

32. The coordinates of points  $A$  and  $B$  are  $(a, 2)$  and  $(3, b)$  respectively, where  $a$  and  $b$  are constants.

The distance  $AB$  is  $\sqrt{125}$  units and the gradient of the line  $AB$  is 2. Find the possible values of  $a$  and of  $b$ .

[J14/P11/Q7]

33. Find the coordinates of the point at which the perpendicular bisector of the line joining  $(2, 7)$  to  $(10, 3)$  meets the  $x$ -axis.

[J14/P12/Q1]

34.

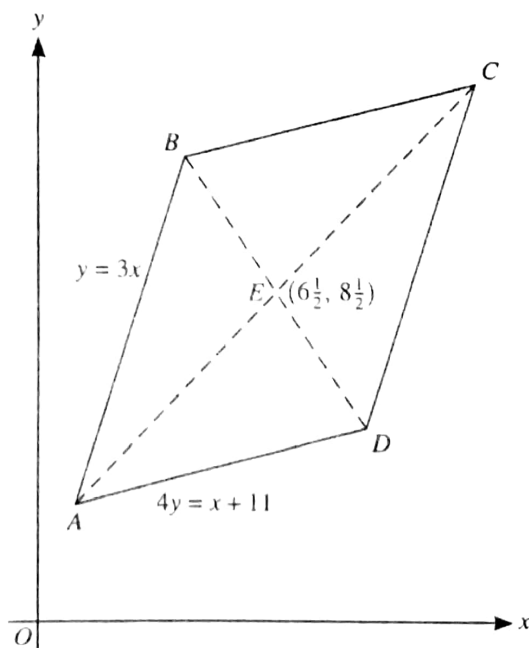

The diagram shows a parallelogram  $ABCD$ , in which the equation of  $AB$  is  $y = 3x$  and the equation of  $AD$  is  $4y = x + 11$ . The diagonals  $AC$  and  $BD$  meet at the point  $E(6\frac{1}{2}, 8\frac{1}{2})$ . Find, by calculation, the coordinates of  $C$  and  $D$ .



35. The line  $4x + ky = 20$  passes through the points  $A(8, -4)$  and  $B(b, 2b)$ , where  $k$  and  $b$  are constants.

- (i) Find the values of  $k$  and  $b$
- (ii) Find the coordinates of the mid-point of  $AB$

[N14/P11/Q4]

36. The diagram shows a trapezium  $ABCD$  in which  $AB$  is parallel to  $DC$  and angle  $BAD$  is  $90^\circ$ . The coordinates of  $A$ ,  $B$  and  $C$  are  $(2, 6)$ ,  $(5, -3)$  and  $(8, 3)$  respectively.

- (i) Find the equation of  $AD$ .
  - (ii) Find, by calculation, the coordinates of  $D$ .
- The point  $E$  is such that  $ABCE$  is a parallelogram.
- (iii) Find the length of  $BE$ .

[N14/P12/Q9]

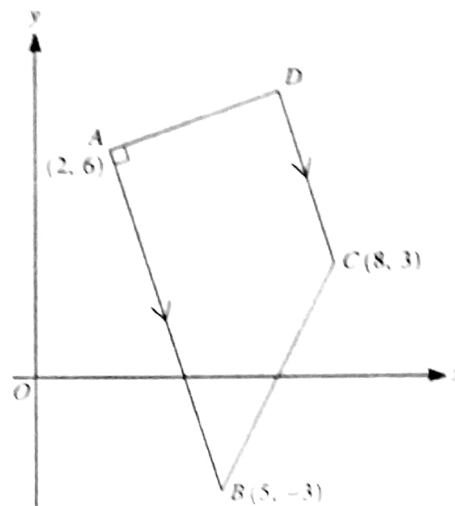

37.  $A$  is the point  $(a, 2a - 1)$  and  $B$  is the point  $(2a + 4, 3a + 9)$ , where  $a$  is a constant.

- (i) Find, in terms of  $a$ , the gradient of a line perpendicular to  $AB$ .
- (ii) Given that the distance  $AB$  is  $\sqrt{260}$ , find the possible values of  $a$ .

[N14/P13/Q6]

38. The line with gradient  $-2$  passing through the point  $P(3t, 2t)$  intersects the  $x$ -axis at  $A$  and the  $y$ -axis at  $B$ .

- (i) Find the area of triangle  $AOB$  in terms of  $t$ .
- The line through  $P$  perpendicular to  $AB$  intersects the  $x$ -axis at  $C$ .
- (ii) Show that the mid-point of  $PC$  lies on the line  $y = x$ .

[J15/P11/Q6]

39. The point  $C$  lies on the perpendicular bisector of the line joining the points  $A(4, 6)$  and  $B(10, 2)$ .  $C$  also lies on the line parallel to  $AB$  through  $(3, 11)$ .

- (i) Find the equation of the perpendicular bisector of  $AB$ .
- (ii) Calculate the coordinates of  $C$ .

[J15/P12/Q7]

40. The point  $A$  has coordinates  $(p, 1)$  and the point  $B$  has coordinates  $(9, 3p + 1)$ , where  $p$  is a constant.

- (i) For the case where the distance  $AB$  is 13 units, find the possible values of  $p$ .
- (ii) For the case in which the line with equation  $2x + 3y = 9$  is perpendicular to  $AB$ , find the value of  $p$ .

[J15/P13/Q7]

41. Points  $A$ ,  $B$  and  $C$  have coordinates  $A(-3, 7)$ ,  $B(5, 1)$  and  $C(-1, k)$ , where  $k$  is a constant.

- (i) Given that  $AB = BC$ , calculate the possible values of  $k$ .
- The perpendicular bisector of  $AB$  intersects the  $x$ -axis at  $D$ .

- (ii) Calculate the coordinates of  $D$ .

[N15/P12/Q8]



42. A curve has equation  $y = 3x - \frac{4}{x}$  and passes through the points  $A(1, -1)$  and  $B(4, 11)$ . At each of the points  $C$  and  $D$  on the curve, the tangent is parallel to  $AB$ . Find the equation of the perpendicular bisector of  $CD$ .  
[J16/P11/Q8]
43. Three points have coordinates  $A(0, 7)$ ,  $B(8, 3)$  and  $C(3k, k)$ . Find the value of the constant  $k$  for which  
(i)  $C$  lies on the line that passes through  $A$  and  $B$ ,  
(ii)  $C$  lies on the perpendicular bisector of  $AB$ .  
[J16/P12/Q8]
44. Triangle  $ABC$  has vertices at  $A(-2, -1)$ ,  $B(4, 6)$  and  $C(6, -3)$ .  
(i) Show that triangle  $ABC$  is isosceles and find the exact area of this triangle.  
(ii) The point  $D$  is the point on  $AB$  such that  $CD$  is perpendicular to  $AB$ . Calculate the  $x$ -coordinate of  $D$ .  
[J16/P13/Q11]
45.  $C$  is the mid-point of the line joining  $A(14, -7)$  to  $B(-6, 3)$ . The line through  $C$  perpendicular to  $AB$  crosses the  $y$ -axis at  $D$ .  
(i) Find the equation of the line  $CD$ , giving your answer in the form  $y = mx + c$ .  
(ii) Find the distance  $AD$ .  
[N16/P11/Q4]
46. The line  $\frac{x}{a} + \frac{y}{b} = 1$ , where  $a$  and  $b$  are positive constants, intersects the  $x$ - and  $y$ -axes at the points  $A$  and  $B$  respectively. The mid-point of  $AB$  lies on the line  $2x + y = 10$  and the distance  $AB = 10$ . Find the values of  $a$  and  $b$ .  
[N16/P12/Q5]
47. Three points,  $A$ ,  $B$  and  $C$ , are such that  $B$  is the mid-point of  $AC$ . The coordinates of  $A$  are  $(2, m)$  and the coordinates of  $B$  are  $(n, -6)$  where  $m$  and  $n$  are constants.  
(i) Find the coordinates of  $C$  in terms of  $m$  and  $n$ .  
The line  $y = x + 1$  passes through  $C$  and is perpendicular to  $AB$ .  
(ii) Find the values of  $m$  and  $n$ .  
[N16/P13/Q6]

## ANSWERS

### Topic 3 - Coordinate Geometry

5. Solving simultaneously gives,  
 $\left(\frac{3}{4}, 3\right)$  and  $(3, 6)$   
 $\therefore$  distance = 3.75 units.
6. (i) Equation of  $CD$ :  $3x + 2y = 48$ .  
 (ii) Equation of  $AB$ :  $3y - 2x = 7$   
 Solve simultaneously equations of  $AB$  and  $CD$   
 $\Rightarrow D(10, 9)$
7. (i) Equation of  $BC$ :  $2x + 3y = 20$ .  
 (ii)  $C(10, 0)$ ,  $D(14, 6)$ .
8. Equation of  $CD$ :  $2x + y = 22$   
 Equation of  $DA$ :  $2y = x + 13$   
 solving simultaneously gives  $D(6.2, 9.6)$ .
9. (i) Equation of  $AC$ :  $2y + x = 16$   
 Equation of  $BX$ :  $2x - y = 2$   
 solving simultaneously gives,  $X(4, 6)$ .  
 (ii)  $D(6, 10)$ .  
 (iii) Perimeter =  $2(|AB| + |BC|)$   
 $= 2(\sqrt{200} + \sqrt{40}) = 40.9$  units.
10. (i) Gradient of tangent at  $P = 2$   
 $\Rightarrow$  Gradient of normal at  $P = -\frac{1}{2}$   
 Equation of normal at  $P$ :  $x + 2y = 4$ .  
 (ii) Solve simultaneously equations of curve and normal.  
 $\Rightarrow Q(-8, 6)$ .  
 (iii)  $|PQ| = 5\sqrt{5}$  units.
11. Equation of  $ABC$ :  $2y = x + 4$   
 Equation of  $BD$ :  $y + 2x = 17$   
 solving simultaneously gives,  $B(6, 5)$ .  
 Mid-point of  $AC$  = coordinates of  $B$   
 $\Rightarrow C(12, 8)$ .
12. (i) Mid-point of  $AC$  is  $(6, 6)$ .  
 mid-point lie on  $BD$ .  
 $BD$  is parallel to  $x$ -axis  
 $\Rightarrow$   $y$ -coordinate of  $D$  is 6.  
 (ii) Gradient of  $AD = \frac{8}{h}$   
 gradient of  $CD = \frac{-8}{h-12}$   
 (iii) (Gradient of  $AD$ )(Gradient of  $CD$ ) =  $-1$   
 $\Rightarrow h = -4$  and  $16$ .  
 $\therefore$   $x$ -coordinate of  $B$  is  $-4$ , and  
 $x$ -coordinate of  $D$  is  $16$ .  
 (iv) Area =  $|AB| \times |AD|$   
 $= 160$  units<sup>2</sup>.
13. (i) Gradient of  $AB = 2$   
 $2m = 2 \Rightarrow m = 1$   
 (ii) Equation of  $AC$ :  $y + 2x = 4$   
 Equation of  $BC$ :  $y - x = 7$   
 solving simultaneously gives,  $C(-1, 6)$ ,  
 (iii) Mid-point of  $AB = (9, 10)$   
 Equation of  $\perp$  of  $AB$ :  $x + 2y = 29$   
 Equation of  $BC$ :  $y - x = 7$   
 solving simultaneously gives,  $D(5, 12)$ .
14. Equation of  $L_1$ :  $x - 3y = -10$   
 Equation of  $L_2$ :  $2x - y = 5$   
 solving simultaneously gives,  $C(5, 5)$ .
15. (i) Mid-point of  $AC = (2, 3)$   
 Gradient of  $\perp$  of  $AC = -3$   
 Equation:  $3x + y = 9$ .  
 (ii)  $B(0, 9)$ ,  $D(4, -3)$   
 (iii)  $|AC| = \sqrt{40}$ ,  $|BD| = \sqrt{160}$   
 Area =  $40$  units<sup>2</sup>.
16. (i) By simultaneous equations,  
 $A(-1, 1)$ ,  $B\left(\frac{2}{3}, 6\right)$ .

- (ii)  $|AB| = 5.27$  units  
Mid-point =  $\left(-\frac{1}{6}, \frac{7}{2}\right)$
17. (i) Mid-point of  $AB = \left(\frac{7}{2}, 2\right)$   
(ii)  $x - 2y + 4 = 0$
18. (i) Solve simultaneously gives,  
 $2x^2 - 5x - 3 = 0$   
 $\Rightarrow (2x + 1)(x - 3) = 0$   
 $Q\left(-\frac{1}{2}, 3\frac{1}{2}\right)$   
(ii) Mid-point of  $AP = (2, 3)$   
Equation  $x + 5y = 17$ .
19. (i) Equation of  $AC: y + 2x = 9$   
Equation of  $L_2: y = \frac{1}{2}x$   
solving simultaneously gives,  $C\left(\frac{18}{5}, \frac{9}{5}\right)$ .  
(ii)  $|AC| = \frac{8\sqrt{5}}{5} = 3.58$  units.
20.  $P(a, 0), Q(0, b)$   
 $|PQ| = \sqrt{45}$   
 $\Rightarrow a^2 + b^2 = 45$   
Gradient of  $PQ = -\frac{1}{2}$   
 $\Rightarrow -\frac{b}{a} = -\frac{1}{2} \Rightarrow a = 2b$   
solving simultaneously gives  
 $a = 6, b = 3$
21. (i) Eqn of  $AC, x - 2y = 1$   
Eqn of  $BD, 2x + y = 12$   
simultaneously solved gives  $M(5, 2)$   
Mid-point of  $BD = M$   
 $\Rightarrow D(7, -2)$   
(ii)  $AM = MC = 3.2$ .
22. (i) At point of intersection,  
 $2x^5 + 3x^3 = 2x$   
 $\Rightarrow x(2x^4 + 3x^2 - 2) = 0$   
 $\Rightarrow 2x^4 + 3x^2 - 2 = 0$   
(ii)  $2x^4 + 3x^2 - 2 = 0$   
 $\Rightarrow (x^2 + 2)(2x^2 - 1) = 0$   
 $\Rightarrow x = \pm \frac{1}{\sqrt{2}}$   
 $A\left(-\frac{1}{\sqrt{2}}, -\sqrt{2}\right), B\left(\frac{1}{\sqrt{2}}, \sqrt{2}\right)$
23. (i) Mid-point of  $AC = (1, 4)$   
Equation of  $MB: 2x + y = 6$   
Coordinates of  $B: (3, 0)$   
(ii) (Gradient of  $AB$ )  $\times$  (Gradient of  $BC$ )  
 $= \left(-\frac{2}{6}\right) \left(\frac{6}{2}\right) = -1$   
 $\therefore AB \perp BC$   
(iii)  $D(-1, 8), |AD| = 2\sqrt{10}$  or 6.32 units.
24. Equation of  $\perp$  of  $AB: 4x + 3y = 6$   
at  $C, y = 0, \therefore C$  is  $\left(\frac{3}{2}, 0\right)$ .  
at  $D, x = 0, \therefore D$  is  $(0, 2)$   
Length of  $CD = 2.5$  units
25. (i)  $x + 2y = 27$   
(ii) Equation of  $AC: 3y - x = 8$   
solve simultaneously equations of  $BC$   
and  $AC$  gives  $C(13, 7)$ .
26. Equation of the line passing through  $(-1, 3)$   
and perpendicular to given line is  $2y - 3x = 9$   
Solving the two equations simultaneously  
gives  $(3, 9)$ , which is the mid-point of  
 $R$  and  $(-1, 3)$   
Therefore using mid-point formula  $R$  is  $(7, 15)$ .
27. (i) Coordinates of  $B$  are  $(0, 1)$   
 $\therefore$  equation of  $BC: x + 2y = 2$   
(ii) Length of  $BC = \sqrt{5}$   
Angle  $BCO = 0.464$  radians.  
Area of shaded region  
 $=$  area of sector  $ABC = 1.16$  unit<sup>2</sup>.
28. (i) Eq of  $AB: 2x + 3y = 46$   
Eq of  $CX: 3x - 2y = 17$   
simultaneously solved gives,  $X(11, 8)$ .  
(ii) Using vectors,  $\vec{AX} = 3\vec{XB}$   
 $\Rightarrow AX : XB = 3 : 1$

29. (i)  $y = 2x - 2$ .
- (ii) Subst.  $C$  in part (i) gives:  $q = 2p - 2$   
 $|OC| = 2 \Rightarrow p^2 + q^2 = 4$   
 solving simultaneously, point  $C$  is,  
 $(0, -2)$  and  $\left(\frac{8}{5}, \frac{6}{5}\right)$ .
30. Equation of  $AC$ :  $8y + x = 64$   
 Equation of  $BC$ :  $x - 2y = 4$   
 solving simultaneously gives,  $C(16, 6)$ .  
 Using vectors, or parallelogram method  
 $D$  is  $(12, 14)$ .
31. (i)  $2y + x = 5$
- (ii) Mid-point of  $AB = (-9, 6)$   
 $\therefore |AC| = 13$  units.
32. (i)  $|AB| = \sqrt{125}$   
 $\Rightarrow \sqrt{(a-3)^2 + (2-b)^2} = 125$   
 Gradient of  $AB = 2$   
 $\Rightarrow \frac{b-2}{3-a} = 2$   
 solving simultaneously gives,  
 $a = -2, b = 12$  or  $a = 8, b = -8$ .
33. Equation of perp. bisector:  $2x - y = 7$   
 coordinates are:  $(3.5, 0)$ .
34. Simultaneously solved equations of  
 $AD$  and  $AB$ , gives  $A(1, 3)$   
 Using  $E$  as the mid-point of  $AC$  gives  $C(12, 14)$   
 Use simultaneous equations, or mid-point  
 to find  $B$  and  $D$ .  $D(9, 5)$   $B(4, 12)$
35. (i)  $k = 3, b = 2$ .
- (ii) Mid-point =  $(5, 0)$ .
36. (i)  $3y = x + 16$ .
- (ii) Equation of  $DC$ :  $y = 27 - 3x$   
 Solve simultaneously equations of  $AD$   
 and  $DC$ .  $\Rightarrow D(6.5, 7.5)$ .
- (iii) Coordinates of  $E(5, 12)$ .  
 Length of  $BE = 15$  units.
37. (i) Gradient perp. to  $AB = \frac{-(a+4)}{a+10}$
- (ii)  $|AB| = \sqrt{260}$   
 $\Rightarrow \sqrt{(2a+4-a)^2 + (3a+9-2a+1)^2} = \sqrt{260}$   
 $\Rightarrow a = -18$  or  $4$ .
38. (i) Equation of line  $AB$ :  $2x + y = 8t$   
 $\Rightarrow A(4t, 0), B(0, 8t)$   
 Area of  $\triangle AOB = 16t^2$ .
- (ii) Equation of line perp. to  $AB$ :  $2y = x + t$   
 $\Rightarrow C(-t, 0)$ .  
 Mid-pt of  $PC = (t, t)$  which lies on  $y = x$ .
39. (i) Equation of  $\perp$  of  $AB$ :  $3x - 2y = 13$
- (ii) Eqn of line  $\parallel$  to  $AB$  and passing  
 through  $(3, 11)$  is:  $2x + 3y = 39$   
 simultaneously solved gives  $C(9, 7)$
40. (i)  $|AB| = 13$   
 $\Rightarrow \sqrt{(9-p)^2 + (3p+1-1)^2} = 13$   
 $\Rightarrow 10p^2 - 18p - 88 = 0$   
 $\Rightarrow p = 4$  or  $-\frac{11}{5}$ .
- (ii) Grad. of given line  $\times$  Grad. of  $AB = -1$   
 $\Rightarrow -\frac{2}{3} \times \frac{3p}{9-p} = -1$   
 $\Rightarrow p = 3$ .
41. (i)  $k = -7$  or  $k = 9$ .
- (ii) Equation of  $\perp$  of  $AB$ :  $3y - 4x = 8$   
 at  $x$ -axis,  $y = 0, \Rightarrow D(-2, 0)$
42. Grad. of curve:  $\frac{dy}{dx} = 3 - \frac{4}{x^2}$ , Grad. of  $AB = 4$   
 $\Rightarrow 3 - \frac{4}{x^2} = 4 \Rightarrow x = \pm 2$   
 subst.  $x$  into eq. of curve gives,  
 $C(2, 4), D(-2, -4)$   
 Mid-point of  $CD = (0, 0)$   
 $\therefore$  Eq. of  $\perp$  of  $CD$ :  $y = -\frac{1}{2}x$

AL Mathematics (P1)

43. (i) Gradient of  $AB =$  gradient of  $AC$   

$$\frac{3-7}{8-0} = \frac{k-7}{3k-0} \Rightarrow k = 2.8$$
- (ii) Mid-point of  $AB$ ,  $M = (4, 5)$   
 (gradient of  $CM$ )  $\times$  (gradient of  $AB$ )  $= -1$   

$$\Rightarrow \left(\frac{5-k}{4-3k}\right)\left(\frac{3-7}{8-0}\right) = -1 \Rightarrow k = 0.6$$

44. (i) Using distance formula,  
 $AB = \sqrt{85}$ ,  $BC = \sqrt{85}$   
 $\therefore \triangle ABC$  is isosceles.  
 Mid-pt of  $AC$ ,  $M = (2, -2)$   
 $\Rightarrow$  ht. of  $\triangle ABC$  is,  $BM$   
 $\therefore$  area of  $\triangle ABC = \frac{1}{2} \times AC \times BM$   
 $= 34 \text{ units}^2$

- (ii) Grad of  $AB = \frac{7}{6} \Rightarrow$  Grad of  $CD = -\frac{6}{7}$   
 Equation of  $AB$ :  $y+1 = \frac{7}{6}(x+2)$   
 Equation of  $CD$ :  $y+3 = -\frac{6}{7}(x-6)$   
 solving simultaneously gives,  $x = \frac{34}{85} = \frac{2}{5}$

45. (i) Mid-pt of  $AB = (4, -2)$ ,  $\therefore C(4, -2)$   
 Grad of  $AB = -\frac{1}{2}$ ,  $\Rightarrow$  Grad of  $CD = 2$   
 Eq. of  $CD$ :  $y+2 = 2(x-4)$   
 $\Rightarrow y = 2x-10$

- (ii)  $A(14, -7)$ ,  $D(0, -10)$   
 $\therefore |AD| = \sqrt{205}$

46. Point  $A$  is  $(a, 0)$ , Point  $B$  is  $(0, b)$   
 Mid-pt of  $AB = \left(\frac{a}{2}, \frac{b}{2}\right)$   
 subst. mid-pt into the line  $2x + y = 10$   

$$\Rightarrow 2\left(\frac{a}{2}\right) + \left(\frac{b}{2}\right) = 10 \Rightarrow b = 20 - 2a \dots\dots\dots(1)$$
  
 given,  $|AB| = 10 \Rightarrow a^2 + b^2 = 100 \dots\dots\dots(2)$   
 solving (1) and (2) simultaneously,  
 $a = 6$ ,  $b = 8$

47. (i) Mid-pt of  $AC =$  point  $B$   
 $\Rightarrow$  point  $C(2n-2, -m-12)$
- (ii) Subst. point  $C$  into  $y = x+1$ ,  
 $\Rightarrow m+2n = -11$   
 Grad. of  $AB \times$  Grad of line  $= -1$   

$$\frac{m+6}{2-n} \times 1 = -1 \Rightarrow m-n = -8$$
  
 solving simultaneously gives,  
 $m = -9$ ,  $n = -1$



Only Rhombuses / ★

ALL OK

# TOPIC 4

## Circular Measure

5. The diagram shows a circle with centre  $O$  and radius 8 cm. Points  $A$  and  $B$  lie on the circle. The tangents at  $A$  and  $B$  meet at the point  $T$ , and  $AT = BT = 15$  cm.

- (i) Show that angle  $AOB$  is 2.16 radians, correct to 3 significant figures.
- (ii) Find the perimeter of the shaded region.
- (iii) Find the area of the shaded region.

[J06/P12/Q7]

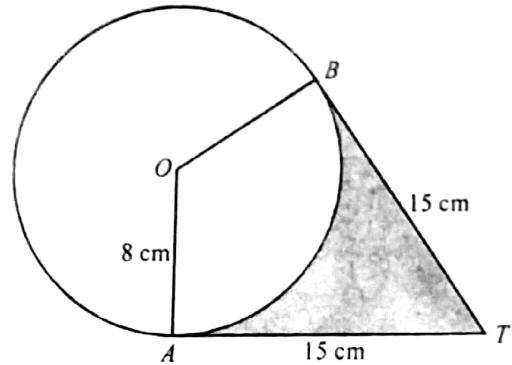

6. In the diagram,  $AOB$  is a sector of a circle with centre  $O$  and radius 12 cm. The point  $A$  lies on the side  $CD$  of the rectangle  $OCDB$ .

Angle  $AOB = \frac{1}{3}\pi$  radians. Express the area of the

shaded region in the form  $a(\sqrt{3}) - b\pi$ , stating the values of the integers  $a$  and  $b$ .

[N06/P12/Q3]

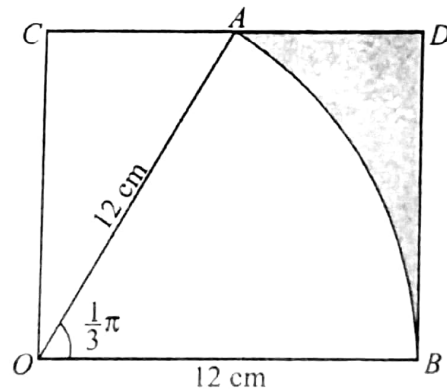

7. In the diagram,  $OAB$  is a sector of a circle with centre  $O$  and radius 12 cm. The lines  $AX$  and  $BX$  are tangents to the circle at  $A$  and  $B$  respectively.

Angle  $AOB = \frac{1}{3}\pi$  radians.

- (i) Find the exact length of  $AX$ , giving your answer in terms of  $\sqrt{3}$ .
- (ii) Find the area of the shaded region, giving your answer in terms of  $\pi$  and  $\sqrt{3}$ .

[J07/P12/Q5]

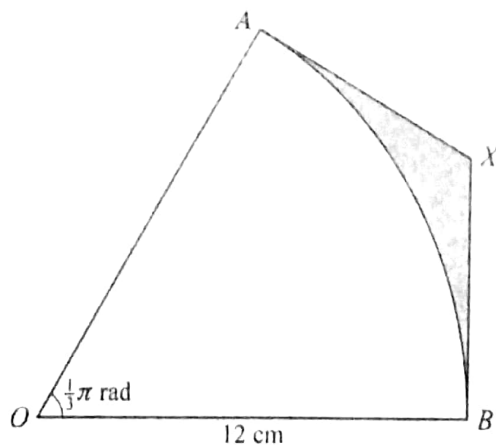



8. In the diagram,  $AB$  is an arc of a circle, centre  $O$  and radius  $r$  cm, and angle  $AOB = \theta$  radians. The point  $X$  lies on  $OB$  and  $AX$  is perpendicular to  $OB$ .

- (i) Show that the area,  $A$  cm<sup>2</sup>, of the shaded region  $AXB$  is given by

$$A = \frac{1}{2}r^2(\theta - \sin\theta\cos\theta).$$

- (ii) In the case where  $r = 12$  and  $\theta = \frac{1}{6}\pi$ , find the perimeter of the shaded region  $AXB$ , leaving your answer in terms of  $\sqrt{3}$  and  $\pi$ .

[N07/P12/Q7]

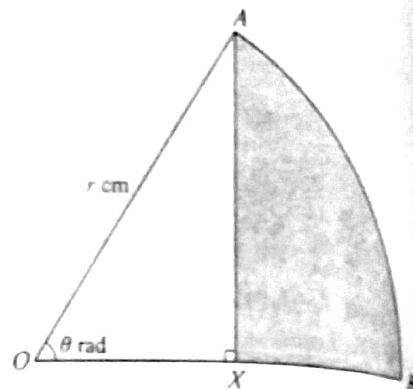

9. The diagram shows a circle with centre  $O$  and radius 5 cm. The point  $P$  lies on the circle,  $PT$  is a tangent to the circle and  $PT = 12$  cm. The line  $OT$  cuts the circle at the point  $Q$ .

- (i) Find the perimeter of the shaded region.  
(ii) Find the area of the shaded region.

[J08/P12/Q5]

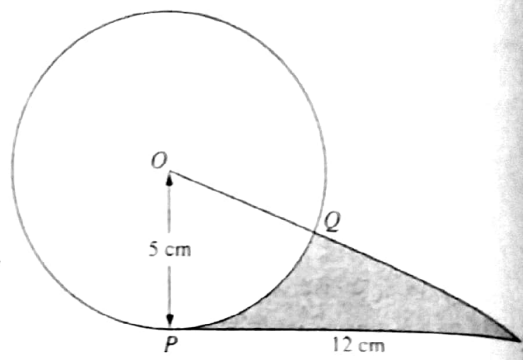

10. In the diagram, the circle has centre  $O$  and radius 5 cm. The points  $P$  and  $Q$  lie on the circle, and the arc length  $PQ$  is 9 cm. The tangents to the circle at  $P$  and  $Q$  meet at the point  $T$ . Calculate

- (i) angle  $POQ$  in radians,  
(ii) the length of  $PT$ ,  
(iii) the area of the shaded region.

[N08/P12/Q6]

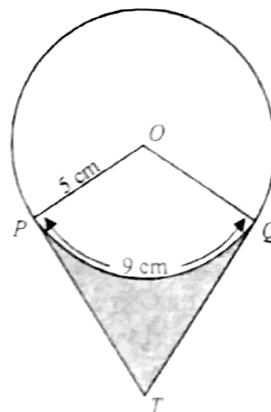

11. The diagram shows a circle with centre  $O$ . The circle is divided into two regions,  $R_1$  and  $R_2$ , by the radii  $OA$  and  $OB$ , where angle  $AOB = \theta$  radians. The perimeter of the region  $R_1$  is equal to the length of the major arc  $AB$ .

- (i) Show that  $\theta = \pi - 1$ .  
(ii) Given that the area of region  $R_1$  is 30 cm<sup>2</sup>, find the area of region  $R_2$ , correct to 3 significant figures.

[J09/P12/Q5]

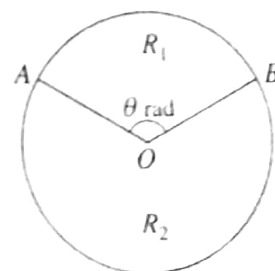

12. The diagram shows a semicircle  $ABC$  with centre  $O$  and radius 6 cm. The point  $B$  is such that angle  $BOA$  is  $90^\circ$  and  $BD$  is an arc of a circle with centre  $A$ . Find

- (i) the length of the arc  $BD$ ,
- (ii) the area of the shaded region.

[N09/P11/Q5]

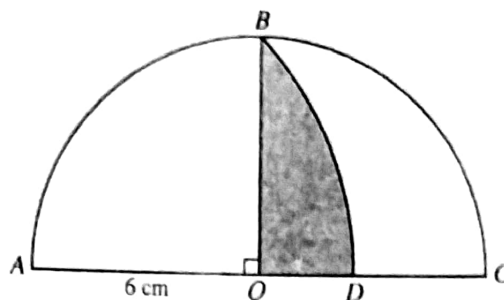

13. The diagram shows a metal plate  $ABCDEF$  which has been made by removing the two shaded regions from a circle of radius 10 cm and centre  $O$ . The parallel edges  $AB$  and  $ED$  are both of length 12 cm.

- (i) Show that angle  $DOE$  is 1.287 radians, correct to 4 significant figures.
- (ii) Find the perimeter of the metal plate.
- (iii) Find the area of the metal plate.

[J10/P13/Q7]

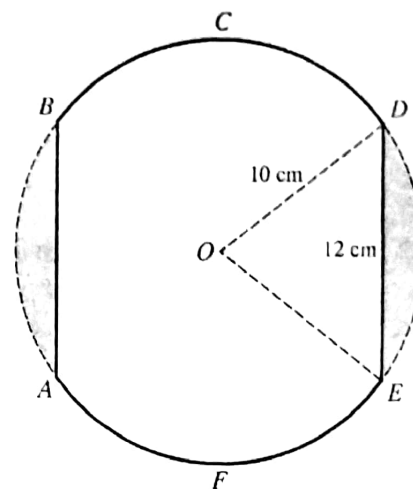

14.

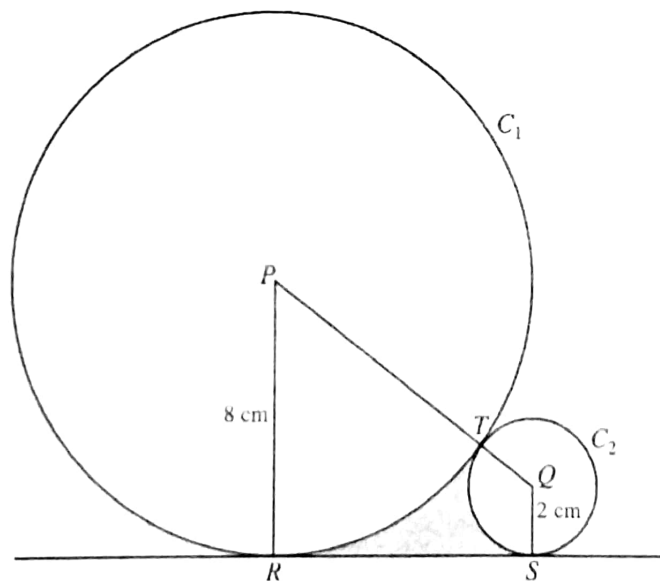

The diagram shows two circles,  $C_1$  and  $C_2$ , touching at the point  $T$ . Circle  $C_1$  has centre  $P$  and radius 8 cm; circle  $C_2$  has centre  $Q$  and radius 2 cm. Points  $R$  and  $S$  lie on  $C_1$  and  $C_2$  respectively, and  $RS$  is a tangent to both circles.

- (i) Show that  $RS = 8$  cm.
- (ii) Find angle  $RPQ$  in radians correct to 4 significant figures.
- (iii) Find

[09]

15. The diagram shows points  $A, C, B, P$  on the circumference of a circle with centre  $O$  and radius 3 cm.

Angle  $AOC = \text{angle } BOC = 2.3$  radians.

- (i) Find angle  $AOB$  in radians, correct to 4 significant figures.  
 (ii) Find the area of the shaded region  $ACBP$ , correct to 3 significant figures.

[N10/P12/Q4]

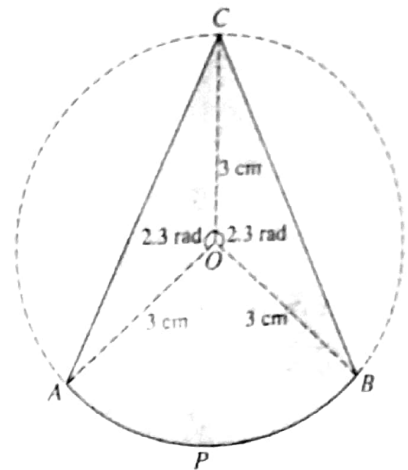

16. The diagram shows a rhombus  $ABCD$ . Points  $P$  and  $Q$  lie on the diagonal  $AC$  such that  $BPD$  is an arc of a circle with centre  $C$  and  $BQD$  is an arc of a circle with centre  $A$ . Each side of the rhombus has length 5 cm and angle  $BAD = 1.2$  radians.

- (i) Find the area of the shaded region  $BPDQ$ .  
 (ii) Find the length of  $PQ$ .

[N10/P13/Q8]

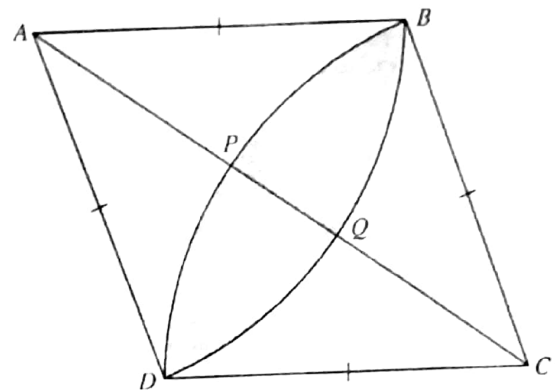

17. In the diagram,  $OAB$  is an isosceles triangle with  $OA = OB$  and angle  $AOB = 2\theta$  radians. Arc  $PST$  has centre  $O$  and radius  $r$ , and the line  $ASB$  is a tangent to the arc  $PST$  at  $S$ .

- (i) Find the total area of the shaded regions in terms of  $r$  and  $\theta$ .

- (ii) In the case where  $\theta = \frac{1}{3}\pi$  and  $r = 6$ , find the total perimeter of the shaded regions, leaving your answer in terms of  $\sqrt{3}$  and  $\pi$ .

[J11/P11/Q9]

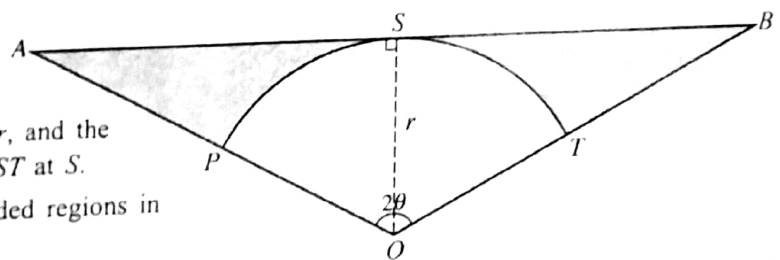

18. In the diagram,  $AB$  is an arc of a circle, centre  $O$  and radius 6 cm, and angle  $AOB = \frac{1}{3}\pi$  radians.

The line  $AX$  is a tangent to the circle at  $A$ , and  $OBX$  is a straight line.

- (i) Show that the exact length of  $AX$  is  $6\sqrt{3}$  cm.

Find, in terms of  $\pi$  and  $\sqrt{3}$ ,

- (ii) the area of the shaded region,  
 (iii) the perimeter of the shaded region.

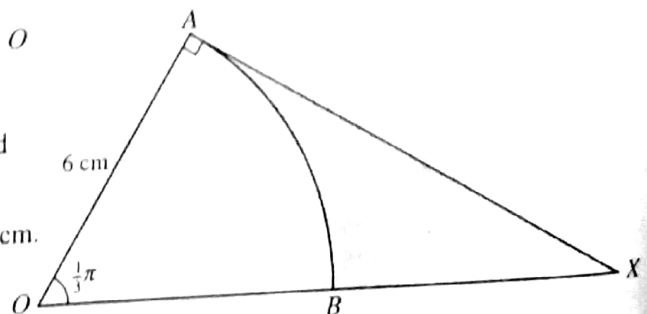

[J11/P13/Q7]



19.

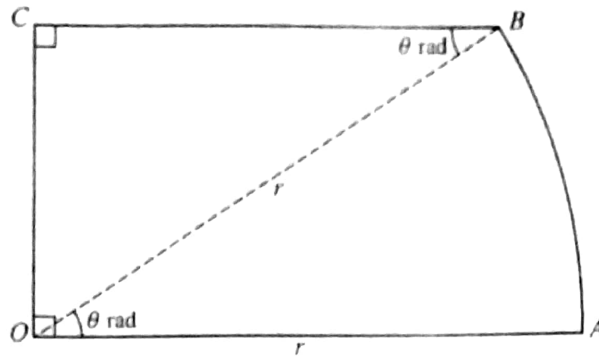

The diagram represents a metal plate  $OABC$ , consisting of a sector  $OAB$  of a circle with centre  $O$  and radius  $r$ , together with a triangle  $OCB$  which is right-angled at  $C$ . Angle  $AOB = \theta$  radians and  $OC$  is perpendicular to  $OA$ .

- (i) Find an expression in terms of  $r$  and  $\theta$  for the perimeter of the plate.
- (ii) For the case where  $r = 10$  and  $\theta = \frac{1}{5}\pi$ , find the area of the plate.

[N11/P11/Q5]

20.

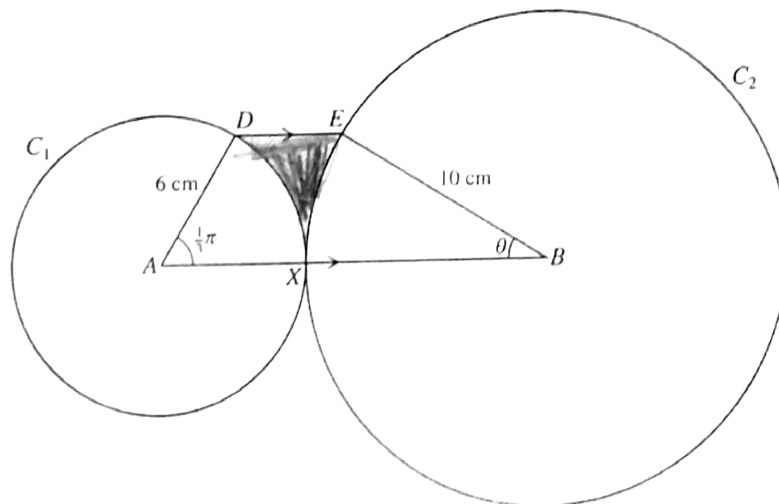

The diagram shows a circle  $C_1$  touching a circle  $C_2$  at a point  $X$ . Circle  $C_1$  has centre  $A$  and radius 6 cm, and circle  $C_2$  has centre  $B$  and radius 10 cm. Points  $D$  and  $E$  lie on  $C_1$  and  $C_2$  respectively and  $DE$  is parallel to  $AB$ . Angle  $DAX = \frac{1}{3}\pi$  radians and angle  $EBX = \theta$  radians.

- (i) By considering the perpendicular distances of  $D$  and  $E$  from  $AB$ , show that the exact value of  $\theta$  is

$$\sin^{-1}\left(\frac{3\sqrt{3}}{10}\right).$$

- (ii) Find the perimeter of the shaded region, correct to 4 significant figures.

[N11/P12/Q6]

- 21. In the diagram,  $ABCD$  is a parallelogram with  $AB = BD = DC = 10$  cm and angle  $ABD = 0.8$  radians.  $APD$  and  $BQC$  are arcs of circles with centres  $B$  and  $D$  respectively.

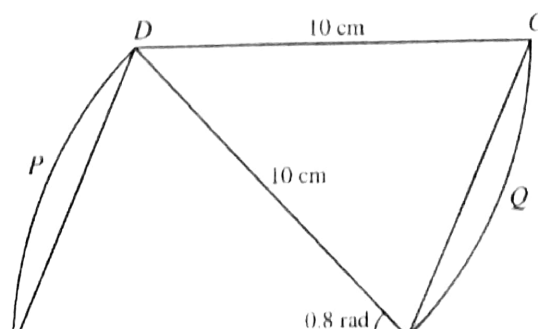

- (i) Find the area of the parallelogram  $ABCD$ .
- (ii) Find the area of the complete figure  $ABQC DP$ .
- (iii) Find the perimeter of the complete figure  $ABQC DP$ .

AL Mathematics (P1)

22. In the diagram,  $ABC$  is an equilateral triangle of side 2 cm. The mid-point of  $BC$  is  $Q$ . An arc of a circle with centre  $A$  touches  $BC$  at  $Q$ , and meets  $AB$  at  $P$  and  $AC$  at  $R$ . Find the total area of the shaded regions, giving your answer in terms of  $\pi$  and  $\sqrt{3}$ .

[J12/P11/Q3]

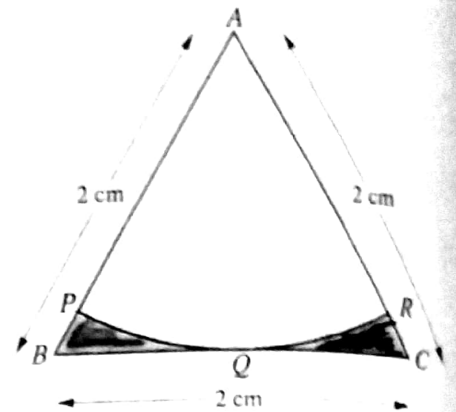

23. The diagram shows a metal plate made by removing a segment from a circle with centre  $O$  and radius 8 cm. The line  $AB$  is a chord of the circle and angle  $AOB = 2.4$  radians. Find

- the length of  $AB$ ,
- the perimeter of the plate,
- the area of the plate.

[J12/P12/Q6]

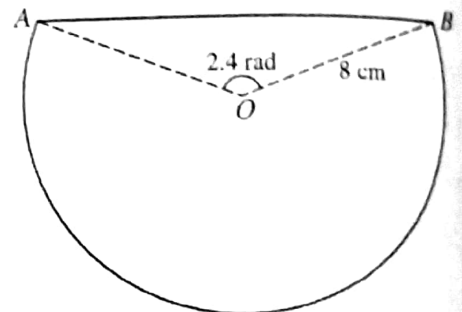

24. In the diagram,  $AB$  is an arc of a circle with centre  $O$  and radius  $r$ . The line  $XB$  is a tangent to the circle at  $B$  and  $A$  is the mid-point of  $OX$ .

- Show that angle  $AOB = \frac{1}{3}\pi$  radians.

Express each of the following in terms of  $r$ ,  $\pi$  and  $\sqrt{3}$ :

- the perimeter of the shaded region,
- the area of the shaded region.

[J12/P13/Q8]

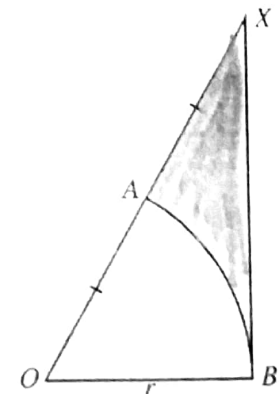

25. The diagram shows a sector  $OAB$  of a circle with centre  $O$  and radius  $r$ . Angle  $AOB$  is  $\theta$  radians. The point  $C$  on  $OA$  is such that  $BC$  is perpendicular to  $OA$ . The point  $D$  is on  $BC$  and the circular arc  $AD$  has centre  $C$ .

- Find  $AC$  in terms of  $r$  and  $\theta$ .
- Find the perimeter of the shaded region  $ABD$  when  $\theta = \frac{1}{3}\pi$  and  $r = 4$ , giving your answer as an exact value.

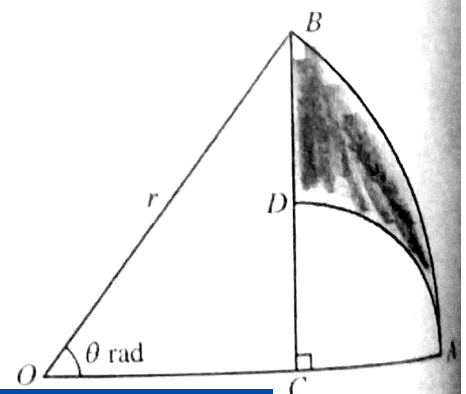



26. The diagram shows a sector of a circle with centre  $O$  and radius 20 cm. A circle with centre  $C$  and radius  $x$  cm lies within the sector and touches it at  $P$ ,  $Q$  and  $R$ . Angle  $POR = 1.2$  radians.
- Show that  $x = 7.218$ , correct to 3 decimal places.
  - Find the total area of the three parts of the sector lying outside the circle with centre  $C$ .
  - Find the perimeter of the region  $OPSR$  bounded by the arc  $PSR$  and the lines  $OP$  and  $OR$ .

[N12/P12/Q11]

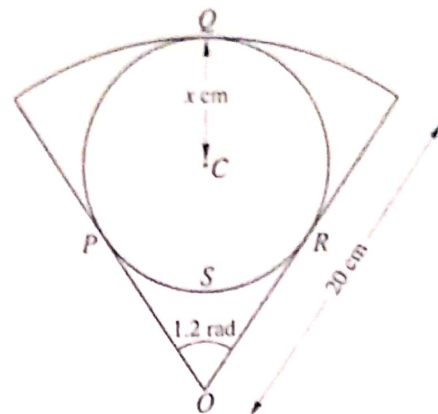

27. In the diagram,  $D$  lies on the side  $AB$  of triangle  $ABC$  and  $CD$  is an arc of a circle with centre  $A$  and radius 2 cm. The line  $BC$  is of length  $2\sqrt{3}$  cm and is perpendicular to  $AC$ . Find the area of the shaded region  $BDC$ , giving your answer in terms of  $\pi$  and  $\sqrt{3}$ .

[N12/P13/Q4]

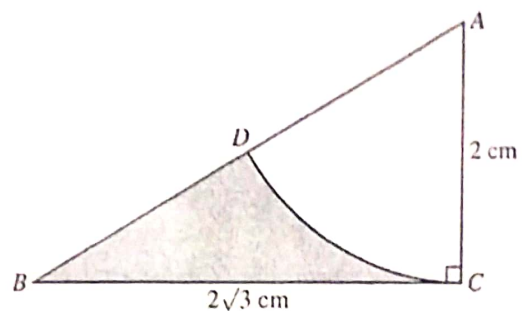

28. In the diagram,  $OAB$  is a sector of a circle with centre  $O$  and radius 8 cm. Angle  $BOA$  is  $\alpha$  radians.  $OAC$  is a semicircle with diameter  $OA$ . The area of the semicircle  $OAC$  is twice the area of the sector  $OAB$ .

- Find  $\alpha$  in terms of  $\pi$ .
- Find the perimeter of the complete figure in terms of  $\pi$ .

[J13/P11/Q3]

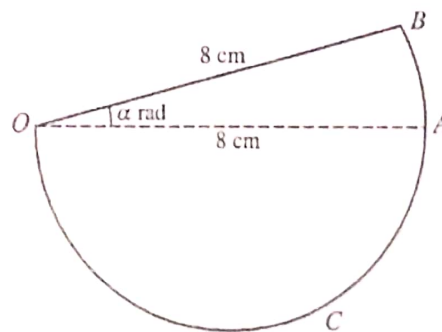

29. The diagram shows a square  $ABCD$  of side 10 cm. The mid-point of  $AD$  is  $O$  and  $BXC$  is an arc of a circle with centre  $O$ .

- Show that angle  $BOC$  is 0.9273 radians, correct to 4 decimal places.
- Find the perimeter of the shaded region.
- Find the area of the shaded region.

[J13/P12/Q4]

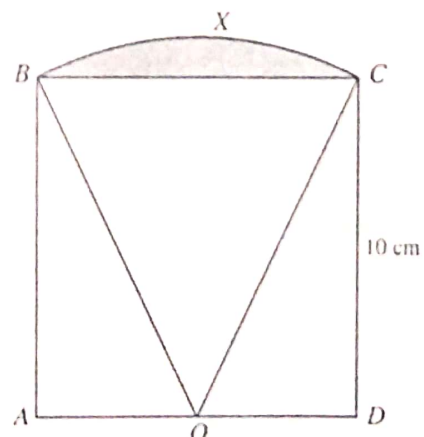



AL Mathematics (P1)

30. The diagram shows a circle  $C$  with centre  $O$  and radius 3 cm. The radii  $OP$  and  $OQ$  are extended to  $S$  and  $R$  respectively so that  $ORS$  is a sector of a circle with centre  $O$ . Given that  $PS = 6$  cm and that the area of the shaded region is equal to the area of circle  $C$ .

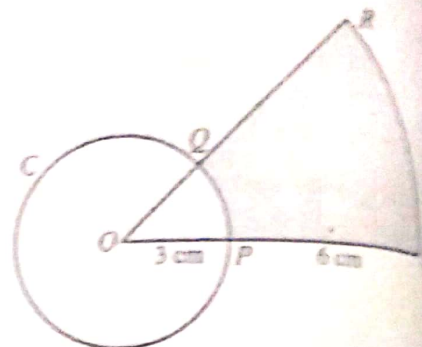

- (i) show that angle  $POQ = \frac{1}{4}\pi$  radians,  
 (ii) find the perimeter of the shaded region.

[J13/P13/Q2]

31. The diagram shows a metal plate made by fixing together two pieces,  $OABCD$  (shaded) and  $OAED$  (unshaded). The piece  $OABCD$  is a minor sector of a circle with centre  $O$  and radius  $2r$ . The piece  $OAED$  is a major sector of a circle with centre  $O$  and radius  $r$ . Angle  $AOD$  is  $\alpha$  radians. Simplifying your answers where possible, find, in terms of  $\alpha$ ,  $\pi$  and  $r$ ,

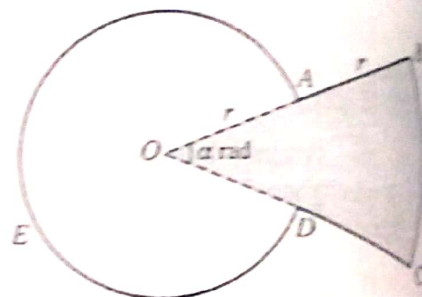

- (i) the perimeter of the metal plate,  
 (ii) the area of the metal plate.

It is now given that the shaded and unshaded pieces are equal in area.

- (iii) Find  $\alpha$  in terms of  $\pi$ .

[N13/P11/Q6]

32.

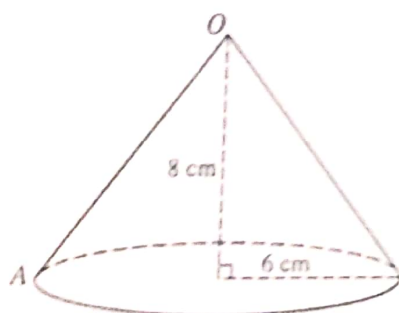

Fig. 1

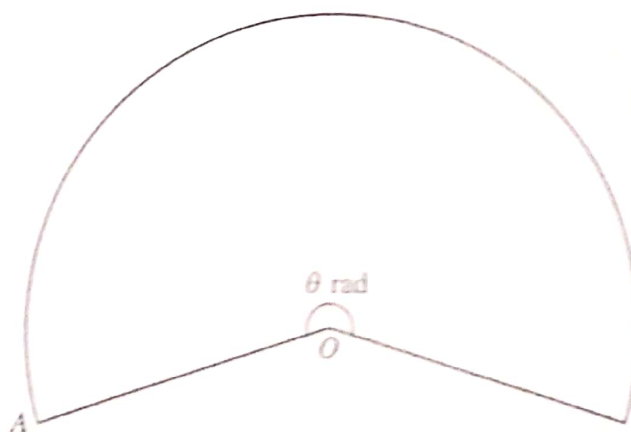

Fig. 2

Fig. 1 shows a hollow cone with no base, made of paper. The radius of the cone is 6 cm and the height is 8 cm. The paper is cut from  $A$  to  $O$  and opened out to form the sector shown in Fig. 2. The circular bottom edge of the cone in Fig. 1 becomes the arc of the sector in Fig. 2. The angle of the sector is  $\theta$  radians. Calculate

- (i) the value of  $\theta$ ,  
 (ii) the area of paper needed to make the cone.

[N13/P12/Q]

33. The diagram shows sector  $OAB$  with centre  $O$  and radius 11 cm. Angle  $AOB = \alpha$  radians. Points  $C$  and  $D$  lie on  $OA$  and  $OB$  respectively. Arc  $CD$  has centre  $O$  and radius 5 cm.

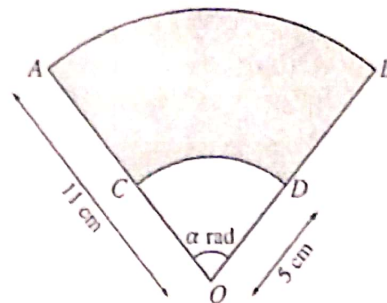

- (i) The area of the shaded region  $ABDC$  is equal to  $k$  times the area of the unshaded region  $OCD$ . Find  $k$ .
- (ii) The perimeter of the shaded region  $ABDC$  is equal to twice the perimeter of the unshaded region  $OCD$ . Find the exact value of  $\alpha$ .

[N13/P13/Q6]

34. The diagram shows triangle  $ABC$  in which  $AB$  is perpendicular to  $BC$ . The length of  $AB$  is 4 cm and angle  $CAB$  is  $\alpha$  radians. The arc  $DE$  with centre  $A$  and radius 2 cm meets  $AC$  at  $D$  and  $AB$  at  $E$ . Find, in terms of  $\alpha$ ,

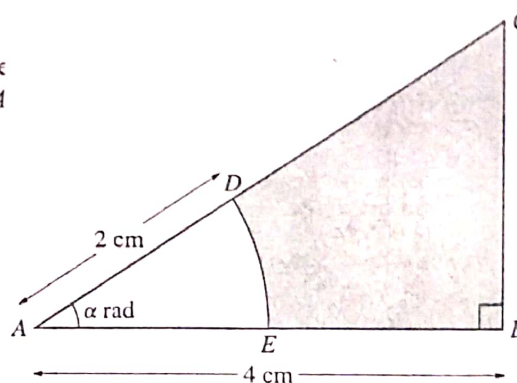

- (i) the area of the shaded region,
- (ii) the perimeter of the shaded region.

[J14/P11/Q6]

35. The diagram shows a sector of a circle with radius  $r$  cm and centre  $O$ . The chord  $AB$  divides the sector into a triangle  $AOB$  and a segment  $AXB$ . Angle  $AOB$  is  $q$  radians.

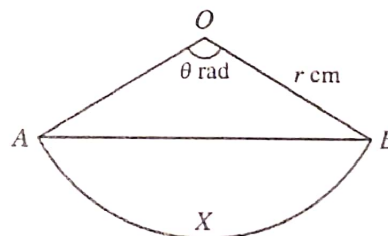

- (i) In the case where the areas of the triangle  $AOB$  and the segment  $AXB$  are equal, find the value of the constant  $p$  for which  $\theta = p \sin \theta$ .
- (ii) In the case where  $r = 8$  and  $\theta = 2.4$ , find the perimeter of the segment  $AXB$ .

[J14/P12/Q4]

36. The diagram shows part of a circle with centre  $O$  and radius 6 cm. The chord  $AB$  is such that angle  $AOB = 2.2$  radians. Calculate

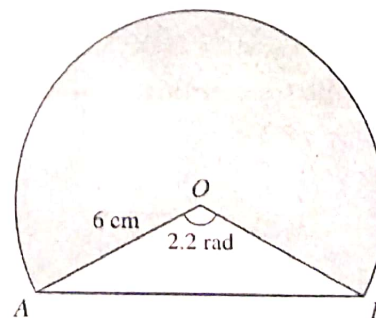

- (i) the perimeter of the shaded region,
- (ii) the ratio of the area of the shaded region to the area of the triangle  $AOB$ , giving your answer in the form  $k : 1$ .

[J14/P13/Q3]

37. In the diagram,  $AB$  is an arc of a circle with centre  $O$  and radius 4 cm. Angle  $AOB$  is  $\alpha$  radians. The point  $D$  on  $OB$  is such that  $AD$  is perpendicular to  $OB$ . The arc  $DC$ , with centre  $O$ , meets  $OA$  at  $C$ .

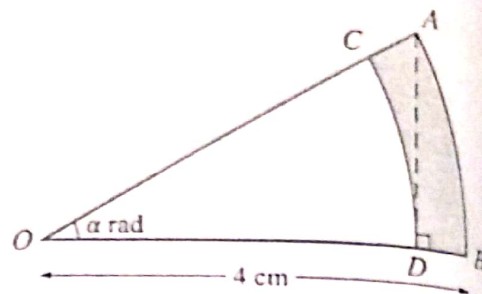

- (i) Find an expression in terms of  $\alpha$  for the perimeter of the shaded region  $ABDC$ .
- (ii) For the case where  $\alpha = \frac{1}{6}\pi$ , find the area of the shaded region  $ABDC$ , giving your answer in the form  $k\pi$ , where  $k$  is a constant to be determined.

[N14/P11/Q8]

38. The diagram shows a triangle  $AOB$  in which  $OA$  is 12 cm,  $OB$  is 5 cm and angle  $AOB$  is a right angle. Point  $P$  lies on  $AB$  and  $OP$  is an arc of a circle with centre  $A$ . Point  $Q$  lies on  $AB$  and  $OQ$  is an arc of a circle with centre  $B$ .

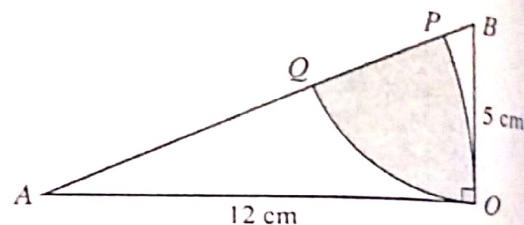

- (i) Show that angle  $BAO$  is 0.3948 radians, correct to 4 decimal places.
- (ii) Calculate the area of the shaded region.

[N14/P12/Q2]

39. In the diagram,  $OADC$  is a sector of a circle with centre  $O$  and radius 3 cm.  $AB$  and  $CB$  are tangents to the circle and angle  $ABC = \frac{1}{3}\pi$  radians. Find, giving your answer in terms of  $\sqrt{3}$  and  $\pi$ ,

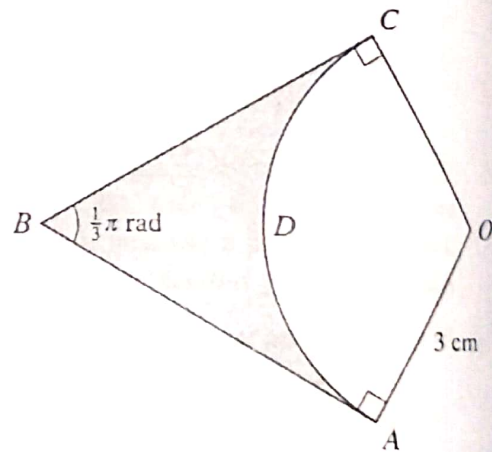

- (i) the perimeter of the shaded region,
- (ii) the area of the shaded region.

[N14/P13/Q2]

40. A piece of wire of length 24 cm is bent to form the perimeter of a sector of a circle of radius  $r$  cm.

- (i) Show that the area of the sector,  $A$  cm<sup>2</sup>, is given by  $A = 12r - r^2$ .
- (ii) Express  $A$  in the form  $a - (r - b)^2$ , where  $a$  and  $b$  are constants.
- (iii) Given that  $r$  can vary, state the greatest value of  $A$  and find the corresponding angle of the sector.

[J15/P11/Q5]



41. In the diagram,  $AYB$  is a semicircle with  $AB$  as diameter and  $OAXB$  is a sector of a circle with centre  $O$  and radius  $r$ . Angle  $AOB = 2\theta$  radians. Find an expression, in terms of  $r$  and  $\theta$ , for the area of the shaded region.

[J15/P12/Q2]

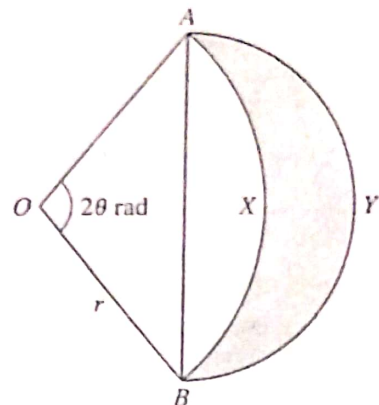

42. In the diagram,  $OAB$  is a sector of a circle with centre  $O$  and radius  $r$ . The point  $C$  on  $OB$  is such that angle  $ACO$  is a right angle. Angle  $AOB$  is  $\alpha$  radians and is such that  $AC$  divides the sector into two regions of equal area.

(i) Show that  $\sin \alpha \cos \alpha = \frac{1}{2} \alpha$ .

It is given that the solution of the equation in part (i) is  $\alpha = 0.9477$ , correct to 4 decimal places.

(ii) Find the ratio  
perimeter of region  $OAC$  : perimeter of region  $ACB$ ,  
giving your answer in the form  $k : 1$ , where  $k$  is given correct to 1 decimal place.

(iii) Find angle  $AOB$  in degrees. [J15/P13/Q11]

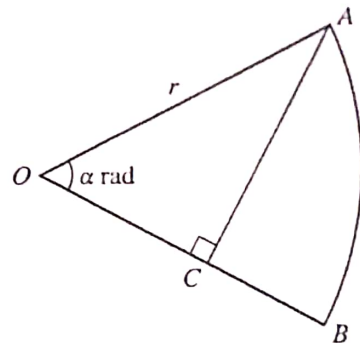

43.

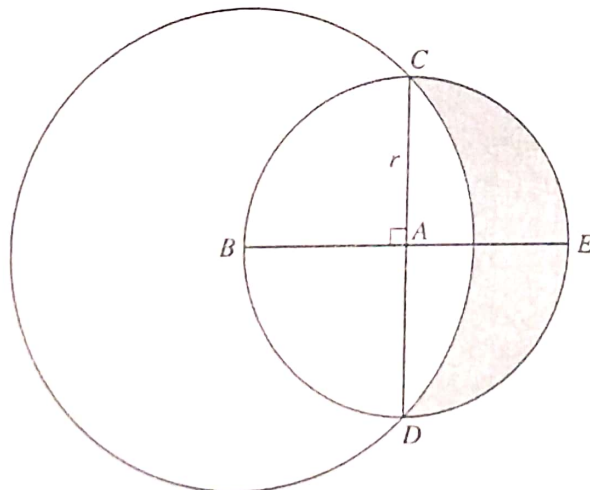

The diagram shows a circle with centre  $A$  and radius  $r$ . Diameters  $CAD$  and  $BAE$  are perpendicular to each other. A larger circle has centre  $B$  and passes through  $C$  and  $D$ .

- (i) Show that the radius of the larger circle is  $r\sqrt{2}$ .  
(ii) Find the area of the shaded region in terms of  $r$ .

[N15/P11/Q7]

AL Mathematics (P1)

44. The diagram shows a metal plate  $OABC$ , consisting of a right-angled triangle  $OAB$  and a sector  $OBC$  of a circle with centre  $O$ . Angle  $AOB = 0.6$  radians,  $OA = 6$  cm and  $OA$  is perpendicular to  $OC$ .

- (i) Show that the length of  $OB$  is 7.270 cm, correct to 3 decimal places.
- (ii) Find the perimeter of the metal plate.
- (iii) Find the area of the metal plate. [N15/P12/Q5]

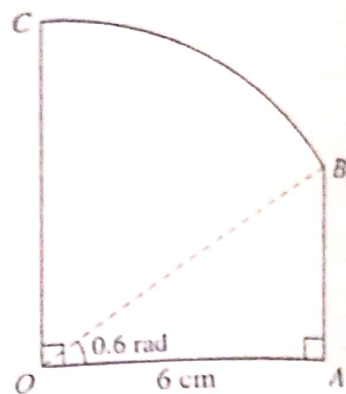

45. The diagram shows a metal plate  $OABCDEF$  consisting of 3 sectors, each with centre  $O$ . The radius of sector  $COD$  is  $2r$  and angle  $COD$  is  $\theta$  radians. The radius of each of the sectors  $BOA$  and  $FOE$  is  $r$ , and  $AOED$  and  $CBOF$  are straight lines.

- (i) Show that the area of the metal plate is  $r^2(\pi + \theta)$ .
- (ii) Show that the perimeter of the metal plate is independent of  $\theta$ . [N15/P13/Q4]

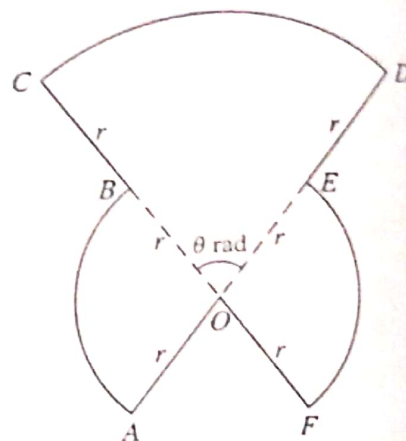

46. In the diagram,  $AOB$  is a quarter circle with centre  $O$  and radius  $r$ . The point  $C$  lies on the arc  $AB$  and the point  $D$  lies on  $OB$ . The line  $CD$  is parallel to  $AO$  and angle  $AOC = \theta$  radians.

- (i) Express the perimeter of the shaded region in terms of  $r$ ,  $\theta$  and  $\pi$ .
- (ii) For the case where  $r = 5$  cm and  $\theta = 0.6$ , find the area of the shaded region. [J16/P11/Q7]

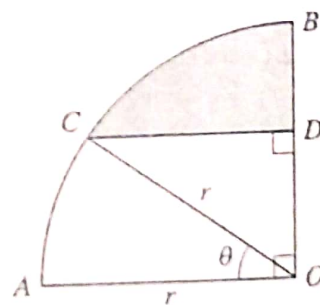

47. The diagram shows a circle with radius  $r$  cm and centre  $O$ . The line  $PT$  is the tangent to the circle at  $P$  and angle  $POT = \alpha$  radians. The line  $OT$  meets the circle at  $Q$ .

- (i) Express the perimeter of the shaded region  $PQT$  in terms of  $r$  and  $\alpha$ .
- (ii) In the case where  $\alpha = \frac{1}{3}\pi$  and  $r = 10$ , find the

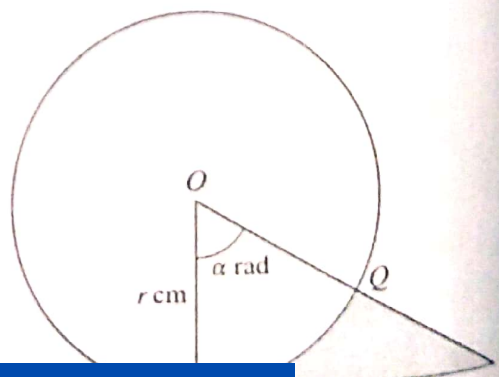

48.

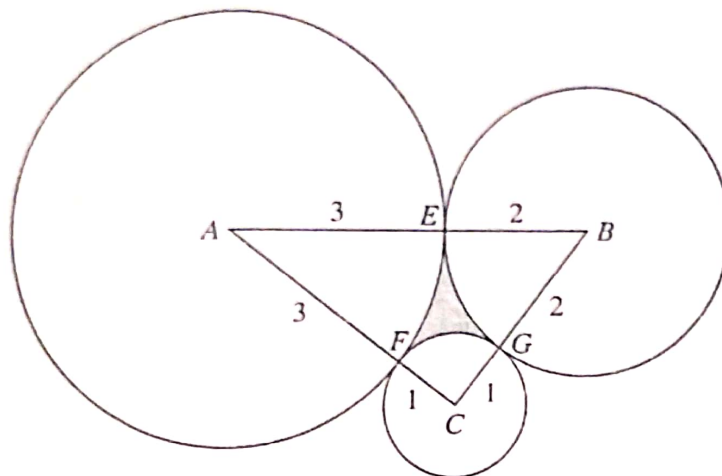

The diagram shows triangle  $ABC$  where  $AB = 5$  cm,  $AC = 4$  cm and  $BC = 3$  cm. Three circles with centres at  $A$ ,  $B$  and  $C$  have radii 3 cm, 2 cm and 1 cm respectively. The circles touch each other at points  $E$ ,  $F$  and  $G$ , lying on  $AB$ ,  $AC$  and  $BC$  respectively. Find the area of the shaded region  $EFG$ .

[J16/P13/Q6]

49. In the diagram  $OCA$  and  $ODB$  are radii of a circle with centre  $O$  and radius  $2r$  cm. Angle  $AOB = \alpha$  radians.  $CD$  and  $AB$  are arcs of circles with centre  $O$  and radii  $r$  cm and  $2r$  cm respectively. The perimeter of the shaded region  $ABDC$  is  $4.4r$  cm.

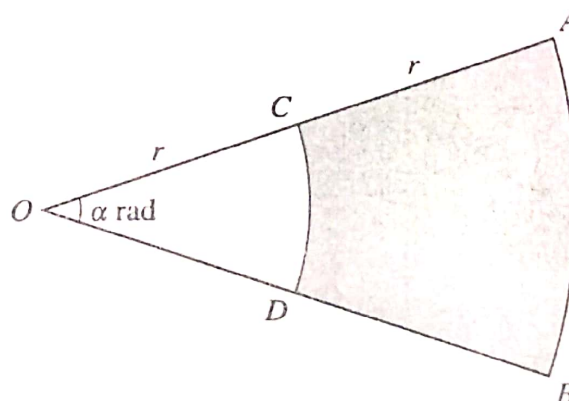

(i) Find the value of  $\alpha$ .

(ii) It is given that the area of the shaded region is  $30$  cm<sup>2</sup>. Find the value of  $r$ .

[N16/P11/Q3]

50. The diagram shows a metal plate  $ABCD$  made from two parts. The part  $BCD$  is a semicircle. The part  $DAB$  is a segment of a circle with centre  $O$  and radius 10 cm. Angle  $BOD$  is 1.2 radians.

(i) Show that the radius of the semicircle is 5.646 cm, correct to 3 decimal places.

(ii) Find the perimeter of the metal plate.

(iii) Find the area of the metal plate.

[N16/P12/Q6]

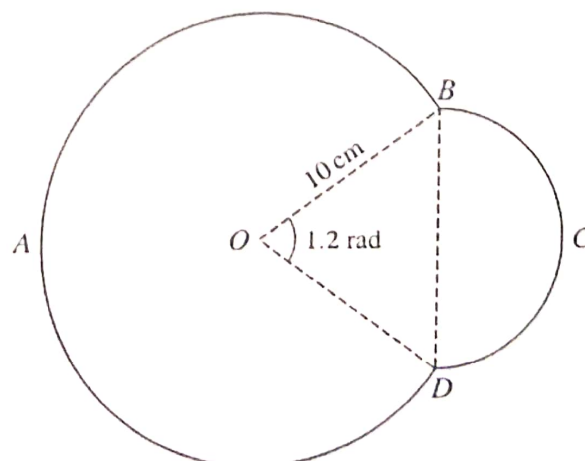



51. The diagram shows a major arc  $AB$  of a circle with centre  $O$  and radius 6 cm. Points  $C$  and  $D$  on  $OA$  and  $OB$  respectively are such that the line  $AB$  is a tangent at  $E$  to the arc  $CED$  of a smaller circle also with centre  $O$ . Angle  $COD = 1.8$  radians.

(i) Show that the radius of the arc  $CED$  is 3.73 cm, correct to 3 significant figures.

(ii) Find the area of the shaded region.

[N16/P13/Q5]

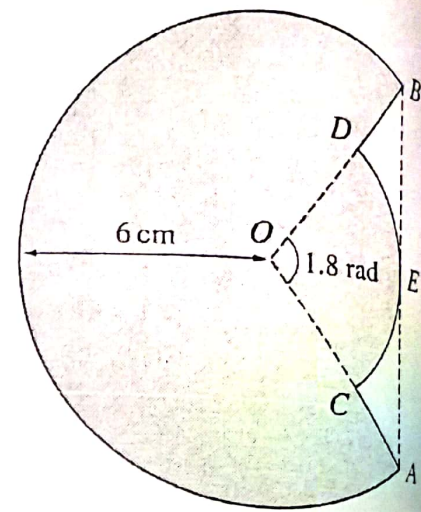

## ANSWERS

### Topic 4 - Circular Measure

5. (i) In  $\triangle OBT$   
 $\Rightarrow \tan \hat{BOT} = \frac{15}{8} \Rightarrow \hat{BOT} = 1.0808$   
 $\hat{AOB} = 2\hat{BOT} = 2.16.$
- (ii) Perimeter =  $\widehat{AB} + BT + AT$   
 $= 47.3 \text{ cm}.$
- (iii) Area of shaded region  
 $= 2(\text{area of } \triangle OBT) - \text{area of sector } OAB$   
 $= 50.9 \text{ cm}^2.$
6. Area of shaded region  
 $= \text{area of trapezium } OBDA - \text{area of sector } OAB$   
 $= (54\sqrt{3} - 24\pi) \text{ cm}^2.$   
 $a = 54, b = 24$
7. (i) In  $\triangle OAX$ ,  $AX = OA \tan \frac{\pi}{6}$   
 $= 4\sqrt{3} \text{ cm}.$
- (ii) Shaded area  
 $= \text{area of kite } OAXB - \text{area of sector } \widehat{OAB}$   
 $= (48\sqrt{3} - 24\pi) \text{ cm}^2.$
8. (i)  $A = \text{area of sector } \widehat{OAB} - \text{area of } \triangle OAX$   
 $= \frac{1}{2}r^2\theta - \frac{1}{2}(r \cos \theta)(r \sin \theta)$   
 $= \frac{1}{2}r^2(\theta - \sin \theta \cos \theta)$
- (ii) Perimeter =  $AX + XB + \widehat{AB}$   
 $= (18 + 2\pi - 6\sqrt{3}) \text{ cm}.$
9. (i) Perimeter =  $\widehat{PQ} + QT + PT$   
 $= 25.9 \text{ cm}$
- (ii) Area of shaded region  
 $= \text{area of } \triangle OPT - \text{area of sector } \widehat{OPQ}$   
 $= 15.3 \text{ cm}^2.$
10. (i)  $\hat{POQ} = 1.8 \text{ rad}.$  (ii)  $PT = 6.30 \text{ cm}.$
- (iii) Shaded area  
 $= \text{area of kite } OPTQ - \text{area of sector } \widehat{OPQ}$   
 $= 9.0$
11. (i) Perimeter of region  $R_1 = \text{Length of major arc}$   
 $\Rightarrow 2r + r\theta = (2\pi - \theta)r$   
 $\Rightarrow r(2 + \theta) = (2\pi - \theta)r \Rightarrow \theta = \pi - 1.$
- (ii) Area of  $R_1 = 30$   
 $\Rightarrow \frac{1}{2}r^2\theta = 30 \Rightarrow r^2 = \frac{60}{\pi - 1}$
- Area of  $R_2 = \frac{1}{2}r^2(2\pi - \theta)$   
 $\Rightarrow \frac{1}{2}\left(\frac{60}{\pi - 1}\right)(\pi + 1) = 58.0 \text{ cm}^2.$
12. (i)  $AB = \sqrt{72}, \hat{BAD} = 45^\circ$   
 $\therefore \text{Arc length } \widehat{BD} = 6.67 \text{ cm}.$
- (ii) Shaded area  
 $= \text{area of sector } \widehat{ABD} - \text{area of } \triangle AOB$   
 $= 10.3 \text{ cm}^2.$
13. (i)  $\hat{DOE} = 2 \sin^{-1}\left(\frac{6}{10}\right)$   
 $= 1.287 \text{ radians}.$
- (ii) Perimeter =  $12 + 12 + 2(\text{arc length } BOD)$   
 $= 61.1 \text{ cm}$
- (iii) Area  
 $= 2(\text{area of } \triangle ODE) + 2(\text{area of sector } BOD)$   
 $= 281 \text{ cm}^2.$
14. (i)  $RS = MQ$   
 $= \sqrt{10^2 - 6^2}$   
 $= 8 \text{ cm}.$
- (ii)  $\hat{RPQ} = 0.927 \text{ rad}.$
- (iii) Area of shaded region  
 $= \text{area of trapezium } RPQS - \text{area of sector } RPT$   
 $- \text{area of sector } TQS$   
 $= 5.90 \text{ cm}^2.$

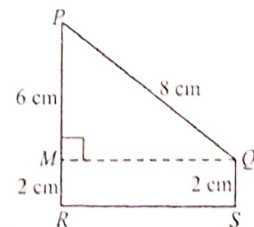

16. (i) Area of shaded region  
 $= 2(\text{area of sector } BCDP - \text{area of } \triangle BCD)$   
 $= 6.70 \text{ cm}^2$ .
- (ii)  $PQ = 2(5 - 5 \cos 0.6)$   
 $= 1.75 \text{ cm}$ .
17. (i) Area = area of  $\triangle OAB$  - area of sector  $OPT$   
 $= r^2(\tan \theta - \theta)$ .
- (ii) Perimeter =  $AP + AB + BT + \widehat{PST}$   
 $= 12 + 12\sqrt{3} + 4\pi$ .
18. (i)  $\tan \frac{\pi}{3} = \frac{AX}{6}$   
 $\Rightarrow AX = 6 \tan \frac{\pi}{3} = 6\sqrt{3}$ .
- (ii) Shaded area  
 $= \text{area of } \triangle OAX - \text{area of sector } OAB$   
 $= 18\sqrt{3} - 6\pi$ .
- (iii) Perimeter of the shaded region  
 $= AX + BX + \widehat{AB}$   
 $= 6\sqrt{3} + 6 + 2\pi$ .
19. (i) Perimeter =  $r + r\theta + r \cos \theta + r \sin \theta$   
 $= r(1 + \theta + \cos \theta + \sin \theta)$
- (i) Area of plate  
 $= \text{area of } \triangle OBC + \text{area of sector } OAB$   
 $= 55.2 \text{ unit}^2$
20. (i) Perpendicular distance from  $D$  to  $AX$   
 $= 6 \sin \frac{\pi}{3} = 3\sqrt{3}$
- Perpendicular distance from  $E$  to  $BX$   
 $= 10 \sin \theta$
- $\Rightarrow 10 \sin \theta = 3\sqrt{3} \Rightarrow \theta = \sin^{-1} \left( \frac{3\sqrt{3}}{10} \right)$ .
- (ii) Perimeter =  $DE + \widehat{DX} + \widehat{EX}$   
 $= 16.20 \text{ cm}$ .
21. (i) Area of Parallelogram =  $2 \times \text{area of } \triangle ABD$   
 $= 71.7 \text{ cm}^2$ .
- (ii) Area of figure = area of 2 sectors  
 $= 80 \text{ cm}^2$ .
- (iii) Perimeter of figure =  $AB + \widehat{BC} + CD + \widehat{AD}$   
 $= 36 \text{ cm}$
22. Radius  $AQ = \sqrt{3}$   
 Area of shaded region  
 $= \text{area of } \triangle ABC - \text{area of sector } APR$   
 $= \sqrt{3} - \frac{\pi}{2}$ .
23. (i) By cosine rule,  $AB = 14.9 \text{ cm}$ .
- (ii) Perimeter = arc length  $\widehat{AB} + AB$   
 $= 46.0 \text{ cm}$
- (iii) Area of plate  
 $= \text{area of major sector } AOB + \text{area of } \triangle AOB$   
 $= 146 \text{ cm}^2$ .
24. (i)  $\cos \widehat{AOB} = \frac{r}{2r} \Rightarrow \widehat{AOB} = \frac{\pi}{3}$  radians.
- (ii) Perimeter =  $\widehat{AB} + BX + AX$   
 $= r \left( 1 + \frac{\pi}{3} + \sqrt{3} \right)$  units.
- (iii) Shaded area =  $\frac{1}{6} r^2 (3\sqrt{3} - \pi)$ .
25. (i)  $AC = r - r \cos \theta$
- (ii)  $\widehat{AB} = \frac{4\pi}{3}$ ,  $\widehat{AD} = \pi$ ,  $BD = 2\sqrt{3} - 2$   
 Perimeter =  $\frac{7\pi}{3} + 2\sqrt{3} - 2$
26. (i) In  $\triangle OCR$ ,  $\sin 0.6 = \frac{CR}{OC}$   
 $\Rightarrow \frac{x}{20-x} = \sin 0.6 \Rightarrow x = 7.218$ .
- (ii) Req. Area = area of sector - area of circle  
 $= 76.3 \text{ cm}^2$ .
- (iii)  $OP = OR = 10.55 \text{ cm}$ ,  $\widehat{PSR} = 14.02 \text{ cm}$   
 perimeter =  $\widehat{PSR} + OP + OR$   
 $= 35.1 \text{ cm}$ .
27. Area of shaded region  
 $= \text{area of } \triangle ABC - \text{area of sector } ADC$   
 $= \left( 2\sqrt{3} - \frac{2\pi}{3} \right) \text{ cm}^2$ .
28. (i) Area of semicircle =  $2 \times \text{area of sector } OAB$   
 $8\pi = 2 \times 32\alpha$   
 $\alpha = \frac{\pi}{8}$
- (ii) Perimeter =  $\widehat{OCA} + \widehat{AB} + OB$

29. (i) In  $\triangle ABO$ ,  
 $\tan \hat{AOB} = \frac{10}{5} \Rightarrow \hat{AOB} = \tan^{-1}(2)$   
 $\hat{BOC} = \pi - 2 \tan^{-1}(2) = 0.9273.$

(ii) Perimeter = arc length  $\widehat{BXC} + BC$   
 $= 20.4 \text{ cm}.$

(iii) Area of shaded region  
 $= \text{area of sector } BOC - \text{area of } \triangle BOC$   
 $= 7.96 \text{ cm}^2.$

30. (i) Area of shaded region = area of circle  $C$   
 $\Rightarrow \frac{1}{2}(9)^2 \hat{POQ} - \frac{1}{2}(3)^2 \hat{POQ} = \pi(3)^2$   
 $\Rightarrow \hat{POQ} = \frac{\pi}{4}.$

(ii) Perimeter =  $PS + \widehat{SR} + RQ + \widehat{QP}$   
 $= 12 + 3\pi$

31. (i) Perimeter of the plate  
 $= AB + \widehat{BC} + CD + \widehat{AED}$   
 $= r(2 + \alpha + 2\pi).$

(ii) Area of plate  
 $= \text{Area of sector } OBC + \text{area of sector } AED$   
 $= \frac{1}{2}r^2(3\alpha + 2\pi).$

(iii) Area of sector  $OBC = \text{area of sector } AED$   
 $\frac{1}{2}(2r)^2\alpha = \frac{1}{2}(r)^2(2\pi - \alpha)$   
 $\alpha = \frac{2}{5}\pi.$

32. (i) Radius of sector in fig.2 = 10 cm  
 Arc length in fig.2 =  $12\pi$   
 $\Rightarrow \theta = 1.2\pi$  radians.

(ii) Area of paper needed = area of sector  
 $= 60\pi \text{ cm}^2.$

33. (i) Area of  $ABDC = k(\text{area of } OCD)$   
 $\Rightarrow k = \frac{96}{25}.$

(ii) Perimeter of  $ABDC = 2(\text{perimeter of } OCD)$   
 $6 + 6 + 11\alpha + 5\alpha = 2(5 + 5 + 5\alpha)$   
 $\alpha = \frac{4}{3}.$

34. (i) Shaded area  
 $= \text{area of } \triangle ABC - \text{area of sector } ADE$   
 $= 8 \tan \alpha - 2\alpha.$

(ii) Perimeter =  $EB + BC + CD + \widehat{DE}$   
 $= \frac{4}{\cos \alpha} + 4 \tan \alpha + 2\alpha.$

35. (i)  $p = 2.$

(ii) Perimeter of segment  $AXB = AB + \widehat{AXB}$   
 $= 34.1 \text{ cm}.$

36. (i) Perimeter of shaded region  
 $= \text{arc length } \widehat{AOB} + OA + OB = 36.5 \text{ cm}.$

(ii) Area of shaded region : Area of  $\triangle AOB$   
 $5.05 : 1$

37. (i)  $AC = DB = 4 - 4 \cos \alpha$   
 Perimeter of shaded region  
 $= DB + \widehat{BA} + AC + \widehat{CD}$   
 $= 8 - 8 \cos \alpha + 4\alpha + 4\alpha \cos \alpha.$

(ii) Area of shaded region  
 $= \text{area of sector } OAB - \text{area of sector } OCD$   
 $= \frac{\pi}{3}.$

38. (i) In  $\triangle AOB$ ,  $\tan \hat{BAO} = \frac{5}{12} \Rightarrow \hat{BAO} = 0.3948.$

(ii) Shaded area  
 $= \text{area of sector } BOQ + \text{area of sector } APO$   
 $- \text{area of } \triangle OBA$   
 $= 13.1 \text{ cm}^2.$

39. (i)  $AB = CB = \frac{3}{\tan \frac{\pi}{6}}$  or  $3\sqrt{3}$

Perimeter of the shaded region  
 $= \widehat{ADC} + AB + BC = 2\pi + 6\sqrt{3}.$

(ii) Area of shaded region  
 $= \text{area of kite} - \text{area of sector } OADC$   
 $= 9\sqrt{3} - 3\pi$

40. (i) Arc length =  $r\theta$   
 $\Rightarrow 24 - 2r = r\theta$   
 $\Rightarrow \theta = \frac{24 - 2r}{r}$

Area of sector =  $\frac{1}{2}r^2 \left( \frac{24 - 2r}{r} \right)$   
 $= 12r - r^2.$

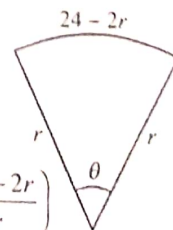

(ii)  $A = -r^2 + 12r$   
 by completing the square method,  
 $A = 36 - (r - 6)^2$



(iii) Greatest value of  $A = 36$ .

subst.  $r = 6$  into  $\theta$ ,

$\theta = 2$  radians.

41.  $AB = 2r \sin \theta$

Area of segment  $AXB = \frac{1}{2}r^2(2\theta - \sin 2\theta)$

Area of shaded region

= area of semi-circle  $AYB$  - area of segment  $AXB$

$= \frac{1}{2}r^2(\pi \sin^2 \theta - 2\theta + \sin 2\theta)$ .

42. (i) Area of  $\triangle OAC =$  area of  $ACB$

$\Rightarrow$  Area of  $\triangle OAC =$  area of sector  $\widehat{OAB}$   
- area of  $\triangle OAC$

$\Rightarrow 2$  area of  $\triangle OAC =$  area of sector  $\widehat{OAB}$

$\Rightarrow 2\left(\frac{1}{2}r^2 \cos \alpha \sin \alpha\right) = \frac{1}{2}r^2 \alpha$

$\Rightarrow \sin \alpha \cos \alpha = \frac{1}{2} \alpha$ .

(ii) Perimeter of  $OAC$  : Perimeter of  $ACB$

$OA + OC + AC : AC + CB + \widehat{AB}$   
1.1 : 1

(iii)  $\widehat{AOB} = 54.3^\circ$ .

43. (i) Radius of larger circle =  $BC$

$= \sqrt{r^2 + r^2} = r\sqrt{2}$ .

(ii) Area of segment

= area of sector  $\widehat{BCD}$  - area of  $\triangle BCD$

$= \frac{1}{2}\pi r^2 - r^2$

Shaded area

= area of semicircle  $CED$  - area of segment

$= \frac{1}{2}\pi r^2 - \left(\frac{1}{2}\pi r^2 - r^2\right)$

$= r^2$ .

44. (i) In  $\triangle OAB$ ,  $\cos 0.6 = \frac{6}{OB}$

$\Rightarrow OB = \frac{6}{\cos 0.6} = 7.270$  cm.

(ii) Perimeter =  $OA + AB + \widehat{BC} + OC$

$= 24.4$  cm.

(iii) Area = area of sector  $OBC$  + area of  $\triangle OAB$

$= 38.0$  cm<sup>2</sup>.

45. (i) Area of the metal plate

$= 2(\text{area of sector } OAB) + \text{area of sector } OCD$

$= 2\left(\frac{1}{2}r^2(\pi - \theta)\right) + \frac{1}{2}(2r)^2\theta$

$= r^2(\pi + \theta)$ .

(ii) Perimeter of the plate

$= OA + \widehat{AB} + BC + \widehat{CD} + DE + \widehat{EF} + OF$

$= 4r + 2r(\pi - \theta) + 2r\theta$

$= r(4 + 2\pi)$ .

46. (i)  $CD \parallel AO \Rightarrow \widehat{OCD} = \theta$

$\Rightarrow CD = r \cos \theta, DB = r - r \sin \theta$

Perimeter =  $CD + DB + \widehat{BC}$

$= r \cos \theta + r - r \sin \theta + r\left(\frac{\pi}{2} - \theta\right)$

(ii) Area of the shaded region

= area of sector  $COB$  - area of  $\triangle COD$

$= \frac{1}{2}r^2\left(\frac{\pi}{2} - \theta\right) - \frac{1}{2}(OD)(CD) = 6.31$  cm<sup>2</sup>

47. (i) In  $\triangle OPT$ ,

$PT = r \tan \alpha, QT = OT - OQ = \frac{r}{\cos \alpha} - r$

Perimeter =  $\widehat{PQ} + PT + QT$

$= r\alpha + r \tan \alpha + \frac{r}{\cos \alpha} - r$

(ii) Area of shaded region

= area of  $\triangle OPT$  - area of sector  $\widehat{OPQ}$

$= \frac{1}{2}(OP)(PT) - \frac{1}{2}r^2\alpha = 34$  cm<sup>2</sup>

48.  $\triangle ABC$  is a right angled triangle

$\widehat{ACB} = \frac{\pi}{2}, \widehat{ABC} = 0.9273, \widehat{BAC} = 0.6435$

Area of the shaded region

= area of  $\triangle ABC$  - area of sectors ( $AEF + BEG + CFG$ )

$= 6 - (2.896 + 1.855 + 0.785) = 0.464$  cm<sup>2</sup>

49. (i)  $r + r + r\alpha + 2r\alpha = 4.4r$

$\Rightarrow \alpha = 0.8$  radians.

(ii) Area of shaded region

= area of sector  $\widehat{OAB}$  - area of sector  $\widehat{OCD}$

$\Rightarrow 30 = 1.6r^2 - 0.4r^2 \Rightarrow r = 5$  cm



50. (i) Using cosine rule on  $\triangle OBD$

$$BD = \sqrt{(10)^2 + (10)^2 - 2(10)(10)\cos(1.2)}$$

$$= 11.2928 \text{ cm}$$

$$\text{radius of semicircle} = \frac{11.2928}{2} = 5.646 \text{ cm.}$$

(ii) Perimeter of the metal plate

$$= \text{length of arc } \widehat{BAD} + \text{length of arc } \widehat{BCD}$$

$$= 10(2\pi - 1.2) + 5.646(\pi) = 68.6 \text{ cm}$$

(iii) Area of metal plate

$$= \text{area of sector } \widehat{BAD} + \text{area of } \triangle OBD$$

$$+ \text{area of semi-circle } \widehat{BCD}$$

$$= 254.159 + 46.602 + 50.073 = 351 \text{ cm}^2$$

51. (i) In  $\triangle OEB$ ,  $\cos 0.9 = \frac{OE}{6} \Rightarrow OE = 3.73$

$\therefore$  radius of arc  $CED = 3.73 \text{ cm.}$

(ii) Shaded area = area of major sector  $OAB$

+ area of sector  $OCD$

$$= 80.7 + 12.52 = 93.2 \text{ cm}^2.$$

7/8/17

Online Classes Megalecture@gmail.com

[www.youtube.com/megalecture](http://www.youtube.com/megalecture)[www.megalecture.com](http://www.megalecture.com)

R-No.

All ok.

Only Question No's

AL Mathematics (P1)

Topic 5 Trigonometry 1

## TOPIC 5

### Trigonometry

7. Solve the equation  $\sin 2x + 3\cos 2x = 0$ , for  $0^\circ \leq x \leq 180^\circ$ .

[J06/P12/Q2]

8.

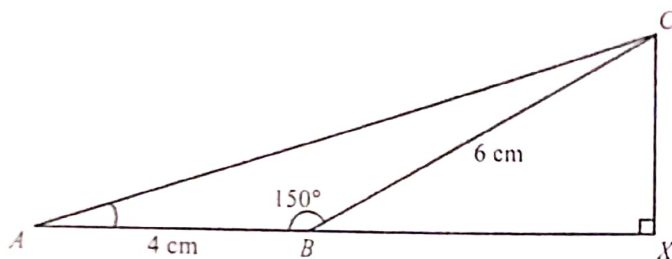

In the diagram,  $ABC$  is a triangle in which  $AB = 4$  cm,  $BC = 6$  cm and angle  $ABC = 150^\circ$ . The line  $CX$  is perpendicular to the line  $ABX$ .

(i) Find the exact length of  $BX$  and show that angle  $CAB = \tan^{-1}\left(\frac{3}{4+3\sqrt{3}}\right)$ .

(ii) Show that the exact length of  $AC$  is  $\sqrt{52 + 24\sqrt{3}}$  cm.

[J06/P12/Q6]

9. Given that  $x = \sin^{-1}\left(\frac{2}{5}\right)$ , find the exact value of

(i)  $\cos^2 x$ ,

(ii)  $\tan^2 x$ .

[N06/P12/Q2]

10. Prove the identity  $\frac{1 - \tan^2 x}{1 + \tan^2 x} \equiv 1 - 2\sin^2 x$ .

[J07/P12/Q3]

11. The function  $f$  is defined by  $f(x) = a + b\cos 2x$ , for  $0 \leq x \leq \pi$ . It is given that  $f(0) = -1$  and  $f\left(\frac{1}{2}\pi\right) = 7$ .

(i) Find the values of  $a$  and  $b$ .

(ii) Find the  $x$ -coordinates of the points where the curve  $y = f(x)$  intersects the  $x$ -axis.

(iii) Sketch the graph of  $y = f(x)$ .

[J07/P12/Q8]

12. (i) Show that the equation  $3\sin x \tan x = 8$  can be written as  $3\cos^2 x + 8\cos x - 3 = 0$ .

(ii) Hence solve the equation  $3\sin x \tan x = 8$  for  $0^\circ \leq x \leq 360^\circ$ .

[N07/P12/Q5]

13. In the triangle  $ABC$ ,  $AB = 12$  cm, angle  $BAC = 60^\circ$  and angle  $ACB = 45^\circ$ . Find the exact length of  $BC$ . [J08/P12/Q1]

14. (i) Show that the equation  $2 \tan^2 \theta \cos \theta = 3$  can be written in the form  $2 \cos^2 \theta + 3 \cos \theta - 2 = 0$ .

(ii) Hence solve the equation  $2 \tan^2 \theta \cos \theta = 3$ , for  $0^\circ \leq \theta \leq 360^\circ$ . [J08/P12/Q2]

15. Prove the identity  $\frac{1 + \sin x}{\cos x} + \frac{\cos x}{1 + \sin x} \equiv \frac{2}{\cos x}$ . [N08/P12/Q2]

16. The function  $f$  is such that  $f(x) = a - b \cos x$  for  $0^\circ \leq x \leq 360^\circ$ , where  $a$  and  $b$  are positive constants. The maximum value of  $f(x)$  is 10 and the minimum value is  $-2$ .

(i) Find the values of  $a$  and  $b$ .

(ii) Solve the equation  $f(x) = 0$ .

(iii) Sketch the graph of  $y = f(x)$ . [N08/P12/Q5]

17. Prove the identity  $\frac{\sin x}{1 - \sin x} - \frac{\sin x}{1 + \sin x} = 2 \tan^2 x$ . [J09/P12/Q1]

18.

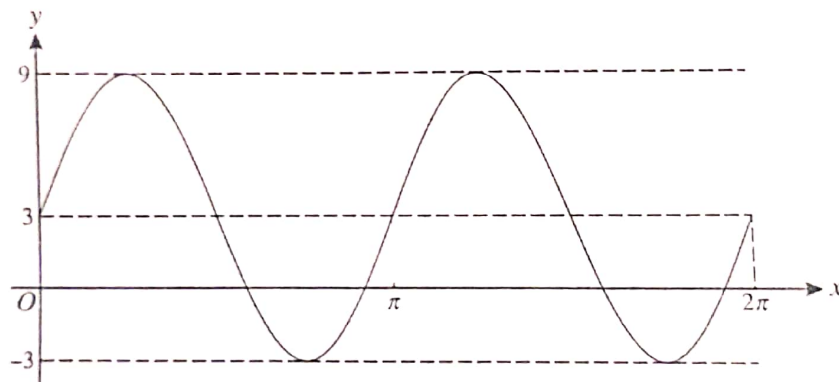

The diagram shows the graph of  $y = a \sin(bx) + c$  for  $0 \leq x \leq 2\pi$ .

(i) Find the values of  $a$ ,  $b$  and  $c$ .

(ii) Find the smallest value of  $x$  in the interval  $0 \leq x \leq 2\pi$  for which  $y = 0$ . [J09/P12/Q4]

19. Solve the equation  $3 \tan(2x + 15^\circ) = 4$  for  $0^\circ \leq x \leq 180^\circ$ . [N09/P11/Q]

20. The equation of a curve is  $y = 3 \cos 2x$ . The equation of a line is  $x + 2y = \pi$ . On the same diagram, sketch the curve and the line for  $0 \leq x \leq \pi$ . [N09/P11/Q]

21. (i) Prove the identity  $(\sin x + \cos x)(1 - \sin x \cos x) \equiv \sin^3 x + \cos^3 x$ .

(ii) Solve the equation  $(\sin x + \cos x)(1 - \sin x \cos x) = 9 \sin^3 x$  for  $0^\circ \leq x \leq 360^\circ$ . [N09/P12/Q]

22. The acute angle  $x$  radians is such that  $\tan x = k$ , where  $k$  is a positive constant. Express, in terms of  $k$ ,
- $\tan(\pi - x)$ ,
  - $\tan(\frac{1}{2}\pi - x)$ ,
  - $\sin x$ .
- [J10/P11/Q1]

23. (i) Show that the equation

$$3(2 \sin x - \cos x) = 2(\sin x - 3 \cos x)$$

can be written in the form  $\tan x = -\frac{3}{4}$ .

- (ii) Solve the equation  $3(2 \sin x - \cos x) = 2(\sin x - 3 \cos x)$ , for  $0^\circ \leq x \leq 360^\circ$ . [J10/P12/Q1]

25. (i) Show that the equation  $2 \sin x \tan x + 3 = 0$  can be expressed as  $2 \cos^2 x - 3 \cos x - 2 = 0$ .

- (ii) Solve the equation  $2 \sin x \tan x + 3 = 0$  for  $0^\circ \leq x \leq 360^\circ$ . [J10/P13/Q4]

26. (i) Prove the identity  $\frac{\sin x \tan x}{1 - \cos x} \equiv 1 + \frac{1}{\cos x}$ .

- (ii) Hence solve the equation  $\frac{\sin x \tan x}{1 - \cos x} + 2 = 0$ , for  $0^\circ \leq x \leq 360^\circ$ . [N10/P11/Q4]

27. Prove the identity  $\tan^2 x - \sin^2 x \equiv \tan^2 x \sin^2 x$ . [N10/P12/Q2]

28. Solve the equation  $15 \sin^2 x = 13 + \cos x$  for  $0^\circ \leq x \leq 180^\circ$ . [N10/P13/Q3]

29. (i) Sketch the curve  $y = 2 \sin x$  for  $0 \leq x \leq 2\pi$ .

- (ii) By adding a suitable straight line to your sketch, determine the number of real roots of the equation

$$2\pi \sin x = \pi - x.$$

State the equation of the straight line.

[N10/P13/Q4]

30. (i) Show that the equation  $2 \tan^2 \theta \sin^2 \theta = 1$  can be written in the form

$$2 \sin^4 \theta + \sin^2 \theta - 1 = 0.$$

- (ii) Hence solve the equation  $2 \tan^2 \theta \sin^2 \theta = 1$  for  $0^\circ \leq \theta \leq 360^\circ$ . [J11/P11/Q5]

31. (i) Prove the identity  $\frac{\cos \theta}{\tan \theta(1 - \sin \theta)} \equiv 1 + \frac{1}{\sin \theta}$ .

- (ii) Hence solve the equation  $\frac{\cos \theta}{\tan \theta(1 - \sin \theta)} = 4$ , for  $0^\circ \leq \theta \leq 360^\circ$ . [J11/P12/Q5]



33. (i) Prove the identity  $\left(\frac{1}{\sin \theta} - \frac{1}{\tan \theta}\right)^2 = \frac{1 - \cos \theta}{1 + \cos \theta}$ .

(ii) Hence solve the equation  $\left(\frac{1}{\sin \theta} - \frac{1}{\tan \theta}\right)^2 = \frac{2}{5}$ , for  $0^\circ \leq \theta \leq 360^\circ$ .

[J11/P13/Q2]

34. (i) Sketch, on a single diagram, the graphs of  $y = \cos 2\theta$  and  $y = \frac{1}{2}$  for  $0 \leq \theta \leq 2\pi$ .

(ii) Write down the number of roots of the equation  $2 \cos 2\theta - 1 = 0$  in the interval  $0 \leq \theta \leq 2\pi$ .

(iii) Deduce the number of roots of the equation  $2 \cos 2\theta - 1 = 0$  in the interval  $10\pi \leq \theta \leq 20\pi$ .

[N11/P11/Q3]

35. (i) Sketch, on the same diagram, the graphs of  $y = \sin x$  and  $y = \cos 2x$  for  $0^\circ \leq x \leq 180^\circ$ .

(ii) Verify that  $x = 30^\circ$  is a root of the equation  $\sin x = \cos 2x$ , and state the other root of this equation for which  $0^\circ \leq x \leq 180^\circ$ .

(iii) Hence state the set of values of  $x$ , for  $0^\circ \leq x \leq 180^\circ$ , for which  $\sin x < \cos 2x$ .

[N11/P12/Q5]

36. (i) Given that,  $3 \sin^2 x - 8 \cos x - 7 = 0$ . Show that, for real values of  $x$ ,  $\cos x = -\frac{2}{3}$ .

(ii) Hence solve the equation

$$3 \sin^2(\theta + 70^\circ) - 8 \cos(\theta + 70^\circ) - 7 = 0$$

for  $0^\circ \leq \theta \leq 180^\circ$ .

[N11/P13/Q5]

37. Solve the equation  $\sin 2x = 2 \cos 2x$ , for  $0^\circ \leq x \leq 180^\circ$ .

[J12/P11/Q1]

38. (i) Prove the identity  $\tan x + \frac{1}{\tan x} = \frac{1}{\sin x \cos x}$ .

(ii) Solve the equation  $\frac{2}{\sin x \cos x} = 1 + 3 \tan x$ , for  $0^\circ \leq x \leq 180^\circ$ .

[J12/P12/Q5]

39. (i) Prove the identity  $\tan^2 \theta - \sin^2 \theta = \tan^2 \theta \sin^2 \theta$ .

(ii) Use this result to explain why  $\tan \theta > \sin \theta$  for  $0^\circ < \theta < 90^\circ$ .

[J12/P13/Q1]

40. (i) Solve the equation  $\sin 2x + 3 \cos 2x = 0$  for  $0^\circ \leq x \leq 360^\circ$ .

(ii) How many solutions has the equation  $\sin 2x + 3 \cos 2x = 0$  for  $0^\circ \leq x \leq 1080^\circ$ .

[J12/P13/Q4]

41. (i) Solve the equation  $2 \cos^2 \theta = 3 \sin \theta$ , for  $0^\circ \leq \theta \leq 360^\circ$ .

(ii) The smallest positive solution of the equation  $2 \cos^2(n\theta) = 3 \sin(n\theta)$ , where  $n$  is a positive integer, is  $10^\circ$ . State the value of  $n$  and hence find the largest solution of this equation in the interval  $0^\circ \leq \theta \leq 360^\circ$ .

[N12/P11/Q1]



42. (i) Show that the equation  $2\cos x = 3\tan x$  can be written as a quadratic equation in  $\sin x$ .  
 (ii) Solve the equation  $2\cos 2y = 3\tan 2y$ , for  $0^\circ \leq y \leq 180^\circ$ . [N12/P12/Q6]
43. Solve the equation  $7\cos x + 5 = 2\sin^2 x$ , for  $0^\circ \leq x \leq 360^\circ$ . [N12/P13/Q3]
44. (i) Show that  $\frac{\sin \theta}{\sin \theta + \cos \theta} + \frac{\cos \theta}{\sin \theta - \cos \theta} \equiv \frac{1}{\sin^2 \theta - \cos^2 \theta}$ .  
 (ii) Hence solve the equation  $\frac{\sin \theta}{\sin \theta + \cos \theta} + \frac{\cos \theta}{\sin \theta - \cos \theta} = 3$ , for  $0^\circ \leq \theta \leq 360^\circ$ . [J13/P11/Q5]
45. It is given that  $a = \sin \theta - 3\cos \theta$  and  $b = 3\sin \theta + \cos \theta$ , where  $0^\circ \leq \theta \leq 360^\circ$ .  
 (i) Show that  $a^2 + b^2$  has a constant value for all values of  $\theta$ .  
 (ii) Find the values of  $\theta$  for which  $2a = b$ . [J13/P12/Q5]
46. (i) Express the equation  $2\cos^2 \theta = \tan^2 \theta$  as a quadratic equation in  $\cos^2 \theta$ .  
 (ii) Solve the equation  $2\cos^2 \theta = \tan^2 \theta$  for  $0 \leq \theta \leq \pi$ , giving solutions in terms of  $\pi$ . [J13/P13/Q3]
47. (i) Sketch, on the same diagram, the curves  $y = \sin 2x$  and  $y = \cos x - 1$  for  $0 \leq x \leq 2\pi$ .  
 (ii) Hence state the number of solutions, in the interval  $0 \leq x \leq 2\pi$ , of the equations  
 (a)  $2\sin 2x + 1 = 0$ ,  
 (b)  $\sin 2x - \cos x + 1 = 0$ . [J13/P13/Q5]
48. (i) Solve the equation  $4\sin^2 x + 8\cos x - 7 = 0$  for  $0^\circ \leq x \leq 360^\circ$ .  
 (ii) Hence find the solution of the equation  $4\sin^2\left(\frac{1}{2}\theta\right) + 8\cos\left(\frac{1}{2}\theta\right) - 7 = 0$  for  $0^\circ \leq \theta \leq 360^\circ$ . [N13/P11/Q4]
49. Given that  $\cos x = p$ , where  $x$  is an acute angle in degrees, find, in terms of  $p$ ,  
 (i)  $\sin x$ ,  
 (ii)  $\tan x$ ,  
 (iii)  $\tan(90^\circ - x)$ . [N13/P12/Q1]
50. (a) Find the possible values of  $x$  for which  $\sin^{-1}(x^2 - 1) = \frac{1}{3}\pi$ , giving your answers correct to 3 decimal places.  
 (b) Solve the equation  $\sin(2\theta + \frac{1}{3}\pi) = \frac{1}{2}$  for  $0 \leq \theta \leq \pi$ , giving  $\theta$  in terms of  $\pi$  in your answers.

51.

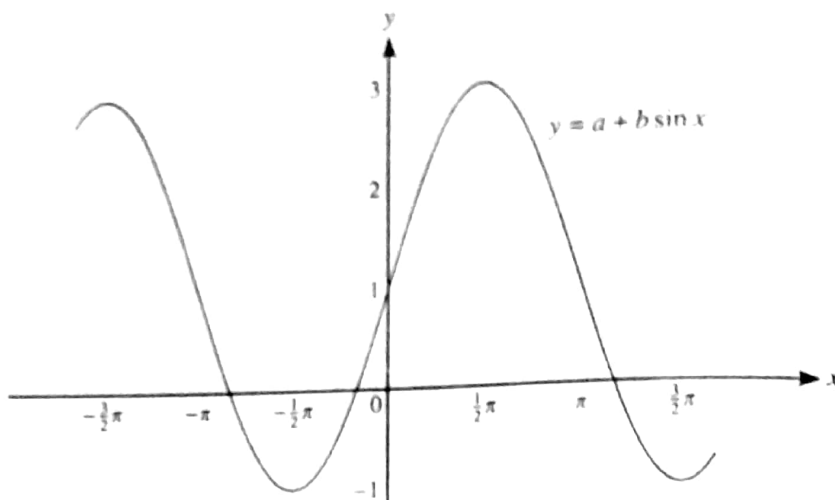

The diagram shows part of the graph of  $y = a + b \sin x$ . State the values of the constants  $a$  and  $b$ .

[J14/P11/Q1]

52. (i) Prove the identity  $\frac{\sin \theta}{1 - \cos \theta} - \frac{1}{\sin \theta} \equiv \frac{1}{\tan \theta}$ .

(ii) Hence solve the equation  $\frac{\sin \theta}{1 - \cos \theta} - \frac{1}{\sin \theta} = 4 \tan \theta$  for  $0^\circ < \theta < 180^\circ$ .

[J14/P11/Q9]

53. The reflex angle  $\theta$  is such that  $\cos \theta = k$ , where  $0 < k < 1$ .

(i) Find an expression, in terms of  $k$ , for

(a)  $\sin \theta$ ,

(b)  $\tan \theta$ .

(ii) Explain why  $\sin 2\theta$  is negative for  $0 < k < 1$ .

[J14/P12/Q3]

54. (i) Prove the identity  $\frac{1}{\cos \theta} - \frac{\cos \theta}{1 + \sin \theta} \equiv \tan \theta$ .

(ii) Solve the equation  $\frac{1}{\cos \theta} - \frac{\cos \theta}{1 + \sin \theta} + 2 = 0$  for  $0^\circ \leq \theta \leq 360^\circ$ .

[J14/P12/Q5]

55. (i) Prove the identity  $\frac{\tan x + 1}{\sin x \tan x + \cos x} \equiv \sin x + \cos x$ .

(ii) Hence solve the equation  $\frac{\tan x + 1}{\sin x \tan x + \cos x} = 3 \sin x - 2 \cos x$  for  $0 \leq x \leq 2\pi$ .

[J14/P13/Q4]

56. Find the value of  $x$  satisfying the equation  $\sin^{-1}(x-1) = \tan^{-1}(3)$ .

[N14/P11/Q2]

57. Solv

58. (i) Show that the equation  $1 + \sin x \tan x = 5 \cos x$  can be expressed as

$$6 \cos^2 x - \cos x - 1 = 0.$$

- (ii) Hence solve the equation  $1 + \sin x \tan x = 5 \cos x$  for  $0 \leq x \leq 180^\circ$ . [N14/P12/Q5]

59. (i) Show that  $\sin^4 \theta - \cos^4 \theta \equiv 2 \sin^2 \theta - 1$ .

- (ii) Hence solve the equation  $\sin^4 \theta - \cos^4 \theta = \frac{1}{2}$  for  $0^\circ \leq \theta \leq 360^\circ$ . [N14/P13/Q5]

60. Given that  $\theta$  is an obtuse angle measured in radians and that  $\sin \theta = k$ , find, in terms of  $k$ , an expression for

(i)  $\cos \theta$ ,

(ii)  $\tan \theta$ ,

(iii)  $\sin(\theta + \pi)$ . [J15/P11/Q1]

61. (i) Prove the identity  $\frac{\sin \theta - \cos \theta}{\sin \theta + \cos \theta} \equiv \frac{\tan \theta - 1}{\tan \theta + 1}$ .

- (ii) Hence solve the equation  $\frac{\sin \theta - \cos \theta}{\sin \theta + \cos \theta} = \frac{\tan \theta}{6}$ , for  $0^\circ \leq \theta \leq 180^\circ$ . [J15/P12/Q5]

62. A tourist attraction in a city centre is a big vertical wheel on which passengers can ride. The wheel turns in such a way that the height,  $h$  m, of a passenger above the ground is given by the formula  $h = 60(1 - \cos kt)$ . In this formula,  $k$  is a constant,  $t$  is the time in minutes that has elapsed since the passenger started the ride at ground level and  $kt$  is measured in radians.

- (i) Find the greatest height of the passenger above the ground.

One complete revolution of the wheel takes 30 minutes.

- (ii) Show that  $k = \frac{1}{15} \pi$ .

- (iii) Find the time for which the passenger is above a height of 90 m. [J15/P12/Q6]

63. (i) Express the equation  $3 \sin \theta = \cos \theta$  in the form  $\tan \theta = k$  and solve the equation for  $0^\circ < \theta < 180^\circ$ .

- (ii) Solve the equation  $3 \sin^2 2x = \cos^2 2x$  for  $0^\circ < x < 180^\circ$ . [J15/P13/Q4]

64. (i) Show that the equation  $\frac{4 \cos \theta}{\tan \theta} + 15 = 0$  can be expressed as

$$4 \sin^2 \theta - 15 \sin \theta - 4 = 0.$$

- (ii) Hence solve the equation  $\frac{4 \cos \theta}{\tan \theta} + 15 = 0$  for  $0^\circ \leq \theta \leq 360^\circ$ . [N15/P11/Q4]

AL Mathematics (P1)

65. (i) Prove the identity  $\left(\frac{1}{\sin x} - \frac{1}{\tan x}\right)^2 = \frac{1 - \cos x}{1 + \cos x}$ .

(ii) Hence solve the equation  $\left(\frac{1}{\sin x} - \frac{1}{\tan x}\right)^2 = \frac{2}{5}$  for  $0 \leq x \leq 2\pi$ .

[N15/P12/Q4]

66. (a) Show that the equation  $\frac{1}{\cos \theta} + 3 \sin \theta \tan \theta + 4 = 0$  can be expressed as  $3 \cos^2 \theta - 4 \cos \theta - 4 = 0$ .

and hence solve the equation  $\frac{1}{\cos \theta} + 3 \sin \theta \tan \theta + 4 = 0$  for  $0^\circ \leq \theta \leq 360^\circ$ .

(b)

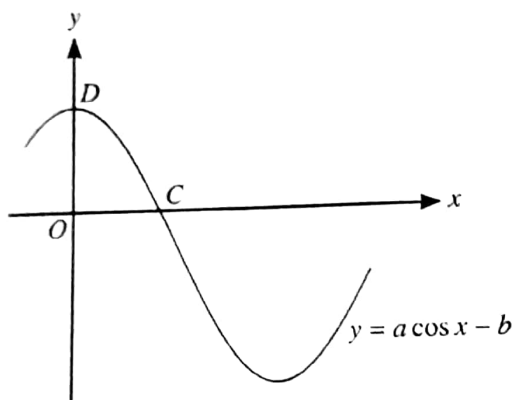

The diagram shows part of the graph of  $y = a \cos x - b$ , where  $a$  and  $b$  are constants. The graph crosses the  $x$ -axis at the point  $C(\cos^{-1} c, 0)$  and the  $y$ -axis at the point  $D(0, d)$ . Find  $c$  and  $d$  in terms of  $a$  and  $b$ .

[N15/P13/Q7]

67. Solve the equation  $3 \sin^2 \theta = 4 \cos \theta - 1$  for  $0^\circ \leq \theta \leq 360^\circ$ .

[J16/P11/Q2]

68. In the diagram, triangle  $ABC$  is right-angled at  $C$  and  $M$  is the mid-point of  $BC$ .

It is given that angle  $ABC = \frac{1}{3}\pi$  radians and angle  $BAM = \theta$  radians. Denoting the lengths of  $BM$  and  $MC$  by  $x$ ,

(i) find  $AM$  in terms of  $x$ ,

(ii) show that  $\theta = \frac{1}{6}\pi - \tan^{-1}\left(\frac{1}{2\sqrt{3}}\right)$ .

[J16/P12/Q5]

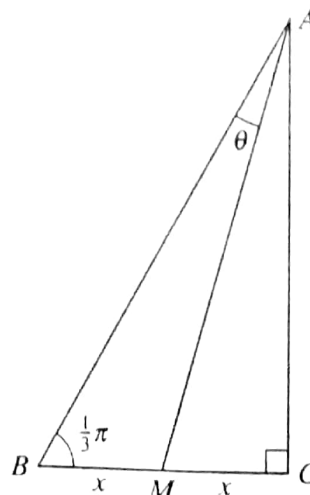

69. (i) Prove the identity  $\frac{1 + \cos \theta}{1 - \cos \theta} - \frac{1 - \cos \theta}{1 + \cos \theta} = \frac{4}{\sin \theta \tan \theta}$ .

(ii) Hence solve, for  $0^\circ < \theta < 360^\circ$ , the equation

$$\sin \theta \left( \frac{1 + \cos \theta}{1 - \cos \theta} - \frac{1 - \cos \theta}{1 + \cos \theta} \right) = 3.$$

[J16/P12/Q7]

70. (i) Show that  $3 \sin x \tan x - \cos x + 1 = 0$  can be written as a quadratic equation in  $\cos x$  and hence solve the equation  $3 \sin x \tan x - \cos x + 1 = 0$  for  $0 \leq x \leq \pi$ .

(ii) Find the solutions to the equation  $3 \sin 2x \tan 2x - \cos 2x + 1 = 0$  for  $0 \leq x \leq \pi$ . [J16/P13/Q8]

71. (i) Show that  $\cos^4 x = 1 - 2 \sin^2 x + \sin^4 x$ .

(ii) Hence, or otherwise, solve the equation  $8 \sin^4 x + \cos^4 x = 2 \cos^2 x$  for  $0^\circ \leq x \leq 360^\circ$ .

[N16/P11/Q6]

72. (i) Express the equation  $\sin 2x + 3 \cos 2x = 3(\sin 2x - \cos 2x)$  in the form  $\tan 2x = k$ , where  $k$  is a constant.

(ii) Hence solve the equation for  $-90^\circ \leq x \leq 90^\circ$ .

[N16/P12/Q2]

73. Showing all necessary working, solve the equation  $6 \sin^2 x - 5 \cos^2 x = 2 \sin^2 x + \cos^2 x$  for  $0^\circ \leq x \leq 360^\circ$ .

[N16/P13/Q3]



# ANSWERS

## Topic 5 - Trigonometry

7.  $\sin 2x + 3 \cos 2x = 0$   
 $\Rightarrow \tan 2x = -3$   
 $\Rightarrow 2x = 108.4, 288.4$   
 $\Rightarrow x = 54.2^\circ, 144.2^\circ$

8. (i)  $BX = 6 \cos 30^\circ = 3\sqrt{3}$   
 $\hat{C}AX = \tan^{-1} \frac{CX}{AX}$   
 $= \tan^{-1} \left( \frac{6 \sin 30^\circ}{4 + 3\sqrt{3}} \right)$   
 $= \tan^{-1} \left( \frac{3}{4 + 3\sqrt{3}} \right)$

(ii)  $AC = \sqrt{(CX)^2 + (AX)^2}$   
 $= \sqrt{(3)^2 + (4 + 3\sqrt{3})^2}$   
 $= \sqrt{52 + 24\sqrt{3}} \text{ cm}$

9. (i)  $\sin x = \frac{2}{5}$   
 $\Rightarrow \cos^2 x = 1 - \sin^2 x = \frac{21}{25}$

(ii)  $\tan^2 x = \frac{\sin^2 x}{\cos^2 x} = \frac{4}{21}$

10.  $\left(1 - \frac{\sin^2 x}{\cos^2 x}\right) + \left(1 + \frac{\sin^2 x}{\cos^2 x}\right)$   
 $\Rightarrow \frac{\cos^2 x - \sin^2 x}{\cos^2 x} \times \frac{\cos^2 x}{\sin^2 x + \cos^2 x}$   
 $\Rightarrow 1 - \sin^2 x - \sin^2 x = 1 - 2\sin^2 x$

11. (i)  $f(0) = -1 \Rightarrow a + b = -1$   
 $f\left(\frac{1}{2}\pi\right) = 7 \Rightarrow a - b = 7$   
 solving simultaneously gives,  
 $a = 3, b = -4$

(ii)  $y = 3 - 4 \cos 2x$   
 put  $y = 0, 3 - 4 \cos 2x = 0 \Rightarrow \cos 2x = \frac{3}{4}$   
 $\Rightarrow 2x = 0.72556 \Rightarrow x = 0.36, 2.78$

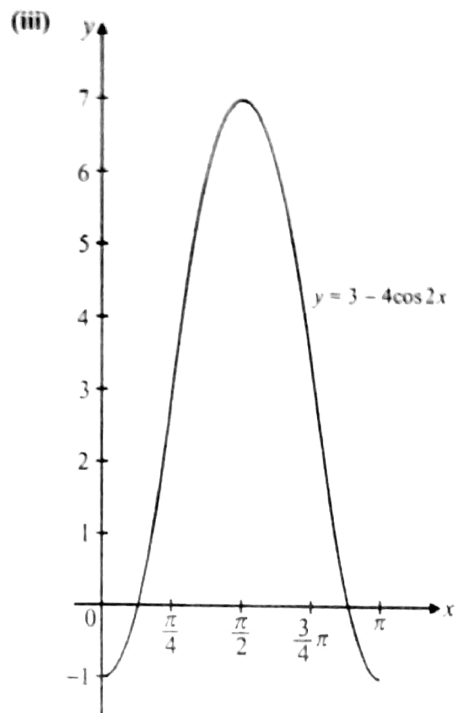

12. (i)  $3 \sin x \tan x = 8$   
 $\Rightarrow 3 \sin x \times \frac{\sin x}{\cos x} = 8$   
 $\Rightarrow 3 \sin^2 x = 8 \cos x$   
 $\Rightarrow 3 \cos^2 x + 8 \cos x - 3 = 0$

(ii)  $3 \cos^2 x + 8 \cos x - 3 = 0$   
 $(\cos x + 3)(3 \cos x - 1) = 0$   
 $\Rightarrow \cos x = -3$  (ignored) or  $\cos x = \frac{1}{3}$   
 $\Rightarrow x = 70.5^\circ, 289.5^\circ$

13. By sine rule,  $BC = \left(\frac{12}{\sin 45^\circ}\right) \sin 60^\circ$   
 $= 6\sqrt{6}$

14. (i)  $2 \tan^2 \theta \cos \theta = 3$   
 $\Rightarrow \frac{2 \sin^2 \theta}{\cos^2 \theta} \times \cos \theta = 3$   
 $\Rightarrow 2 \sin^2 \theta = 3 \cos \theta$   
 $\Rightarrow 2(1 - \cos^2 \theta) = 3 \cos \theta$   
 $\Rightarrow 2 \cos^2 + 3 \cos \theta - 2 = 0$

AL Mathematics (P1)

(ii)  $2\cos^2 + 3\cos\theta - 2 = 0$   
 $\Rightarrow (\cos\theta + 2)(2\cos\theta - 1) = 0$   
 $\Rightarrow \cos\theta = \frac{1}{2}$  or  $\cos\theta = -2$  (not possible)  
 $\Rightarrow \theta = 60^\circ, 300^\circ$

15. L.H.S.  $= \frac{1 + \sin x}{\cos x} + \frac{\cos x}{1 + \sin x}$   
 $= \frac{(1 + \sin x)^2 + (\cos x)^2}{\cos x(1 + \sin x)}$   
 $= \frac{1 + 2\sin x + \sin^2 x + \cos^2 x}{\cos x(1 + \sin x)}$   
 $= \frac{2(1 + \sin x)}{\cos x(1 + \sin x)} = \frac{2}{\cos x}$

16. (i) We know that,  $-1 \leq \cos x \leq 1$   
 multiply by  $-b$  and adding  $a$ ,  
 $a - b \leq a - b\cos x \leq a + b$   
 $\therefore$  min. value  $= a - b$ , max. value  $= a + b$   
 $\Rightarrow a - b = -2$  and  $a + b = 10$   
 by simultaneous equations,  
 $a = 4, b = 6$

(ii)  $f(x) = 4 - 6\cos x$   
 $\Rightarrow 4 - 6\cos x = 0 \Rightarrow \cos x = \frac{2}{3}$   
 $x = 48.2^\circ$  or  $311.8^\circ$

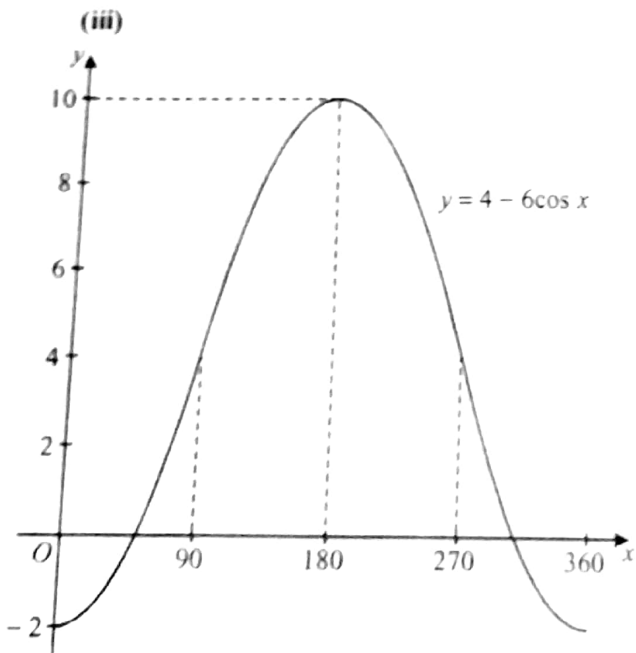

17. L.H.S.  $= \frac{\sin x}{1 - \sin x} - \frac{\sin x}{1 + \sin x}$   
 $= \frac{\sin x(1 + \sin x) - \sin x(1 - \sin x)}{(1 - \sin x)(1 + \sin x)}$

18. (i)  $a = 6, b = 2, c = 3$  Ans.

(ii)  $6\sin 2x + 3 = 0$   
 $\Rightarrow \sin 2x = \frac{-1}{2} \Rightarrow 2x = \frac{7\pi}{6}$

smallest value of  $x = \frac{7\pi}{12}$  Ans.

19.  $2x + 15^\circ = \tan^{-1} \frac{4}{3}$   
 $\Rightarrow 2x + 15^\circ = 53.13^\circ, 233.13^\circ$   
 $\Rightarrow x = 19.1^\circ, 109.1^\circ$  Ans.

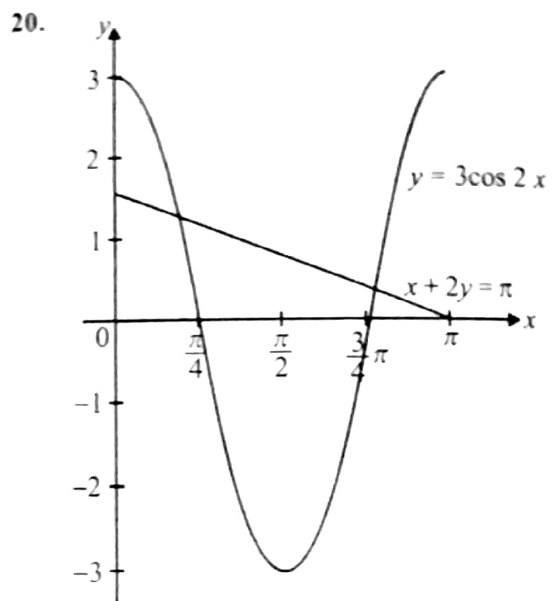

21. (i) L.H.S.  $= (\sin x + \cos x)(1 - \sin x \cos x)$   
 $= (\sin x + \cos x)(\sin^2 x + \cos^2 x - \sin x \cos x)$   
 $= \sin^3 x + \sin x \cos^2 x - \sin^2 x \cos x$   
 $\quad + \cos x \sin^2 x + \cos^3 x - \sin x \cos^2 x$   
 $= \sin^3 x + \cos^3 x$

(ii)  $\sin^3 x + \cos^3 x = 9\sin^3 x$   
 $\Rightarrow \tan^3 x = \frac{1}{8} \Rightarrow \tan x = \frac{1}{2}$   
 $\therefore x = 26.6^\circ, 206.6^\circ$

22. (i)  $\tan(\pi - x) = -\tan x = -k$

(ii)  $\tan\left(\frac{1}{2}\pi - x\right) = \frac{1}{\tan x} = \frac{1}{k}$

(iii)  $\sin x = \frac{k}{\sqrt{1+k^2}}$



23. (i)  $3(2\sin x - \cos x) = 2(\sin x - 3\cos x)$   
 $\Rightarrow 6\sin x - 3\cos x = 2\sin x - 6\cos x$   
 $\Rightarrow 4\sin x = -3\cos x \Rightarrow \tan x = -\frac{3}{4}$

(ii)  $x = 143.1^\circ, 323.1^\circ$

25. (i)  $2\sin x \tan x + 3 = 0$   
 $\Rightarrow 2\sin x \left(\frac{\sin x}{\cos x}\right) + 3 = 0$   
 $\Rightarrow 2\sin^2 x + 3\cos x = 0$   
 $\Rightarrow 2(1 - \cos^2 x) + 3\cos x = 0$   
 $\Rightarrow 2\cos^2 x - 3\cos x - 2 = 0$

(ii)  $2\cos^2 x - 3\cos x - 2 = 0$   
 $\Rightarrow (2\cos x + 1)(\cos x - 2) = 0$   
 $\Rightarrow \cos x = -\frac{1}{2}$  or  $\cos x = 2$  (impossible)  
 $\Rightarrow x = 120^\circ, 240^\circ$

26. (i) L.H.S.  $\equiv \frac{\sin x \tan x}{1 - \cos x}$   
 $= \sin x \left(\frac{\sin x}{\cos x}\right) \div (1 - \cos x)$   
 $= \frac{\sin^2 x}{\cos x} \times \frac{1}{1 - \cos x}$   
 $= \frac{(1 - \cos x)(1 + \cos x)}{\cos x(1 - \cos x)} = 1 + \frac{1}{\cos x}$

(ii)  $1 + \frac{1}{\cos x} + 2 = 0 \Rightarrow \cos x = -\frac{1}{3}$   
 $x = 109.5^\circ, 250.5^\circ$

27. L.H.S.  $\equiv \tan^2 x - \sin^2 x$   
 $= \frac{\sin^2 x}{\cos^2 x} - \sin^2 x$   
 $= \sin^2 x \left(\frac{1}{\cos^2 x} - 1\right)$   
 $= \sin^2 x \left(\frac{1 - \cos^2 x}{\cos^2 x}\right)$   
 $= \sin^2 x \left(\frac{\sin^2 x}{\cos^2 x}\right) = \tan^2 x \sin^2 x$

28.  $15\sin^2 x = 13 + \cos x$   
 $\Rightarrow 15\cos^2 x + \cos x - 2 = 0$   
 $\Rightarrow (5\cos x + 2)(3\cos x - 1) = 0$   
 $\cos x = \frac{1}{3}$  or  $\cos x = -\frac{2}{5}$   
 $x = 70.5^\circ, 113.6^\circ$

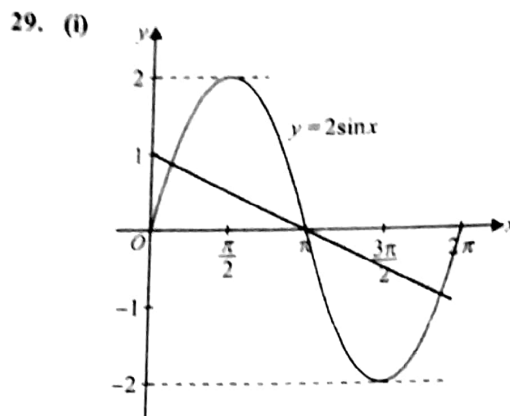

(ii) Number of real roots = 3

Equation:  $y = 1 - \frac{x}{\pi}$

30. (i)  $2\tan^2 \theta \sin^2 \theta = 1$   
 $\Rightarrow \frac{2\sin^2 \theta}{\cos^2 \theta} \times \sin^2 \theta = 1$   
 $\Rightarrow 2\sin^4 \theta = \cos^2 \theta$   
 $\Rightarrow 2\sin^4 \theta + \sin^2 \theta - 1 = 0$

(ii)  $2\sin^4 \theta + \sin^2 \theta - 1 = 0$   
 $\Rightarrow (2\sin^2 \theta - 1)(\sin^2 \theta + 1) = 0$   
 $\Rightarrow \sin \theta = \pm \frac{1}{\sqrt{2}}$  or  $\sin^2 \theta = -1$  (impossible)  
 $\Rightarrow \theta = 45^\circ, 135^\circ, 225^\circ, 315^\circ$

31. (i) L.H.S.  $= \frac{\cos \theta}{\tan \theta(1 - \sin \theta)}$   
 $= \frac{\cos \theta}{\frac{\sin \theta}{\cos \theta}(1 - \sin \theta)}$   
 $= \frac{\cos^2 \theta}{\sin \theta(1 - \sin \theta)}$   
 $= \frac{1 - \sin^2 \theta}{\sin \theta(1 - \sin \theta)}$   
 $= \frac{1 + \sin \theta}{\sin \theta} = 1 + \frac{1}{\sin \theta}$

(ii)  $1 + \frac{1}{\sin \theta} = 4 \Rightarrow \sin \theta = \frac{1}{3}$   
 $\therefore \theta = 19.5^\circ, 160.5^\circ$

33. (i) L.H.S. =  $\left(\frac{1}{\sin \theta} - \frac{1}{\tan \theta}\right)^2$   
 $= \left(\frac{1}{\sin \theta} - \frac{\cos \theta}{\sin \theta}\right)^2$   
 $= \frac{(1 - \cos \theta)^2}{\sin^2 \theta}$   
 $= \frac{(1 - \cos \theta)^2}{1 - \cos^2 \theta} = \frac{1 - \cos \theta}{1 + \cos \theta}$

(ii)  $\frac{1 - \cos \theta}{1 + \cos \theta} = \frac{2}{5}$   
 $\Rightarrow 7 \cos \theta = 3 \Rightarrow \cos \theta = \frac{3}{7}$   
 $\Rightarrow \theta = 64.6^\circ, 295.4^\circ$

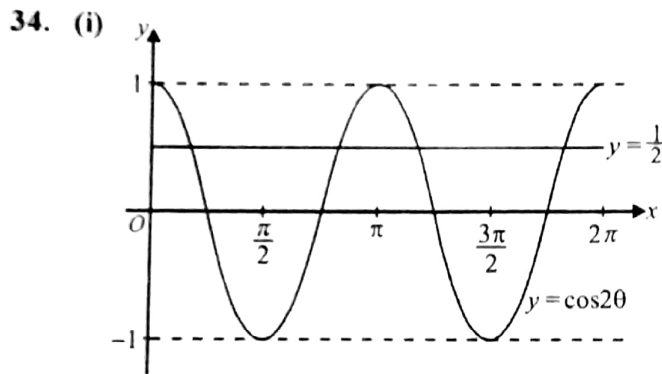

(ii)  $2 \cos 2\theta - 1 = 0 \Rightarrow \cos 2\theta = \frac{1}{2}$

$\therefore$  Number of real roots = 4

(iii) Number of roots = 20

35. (i)

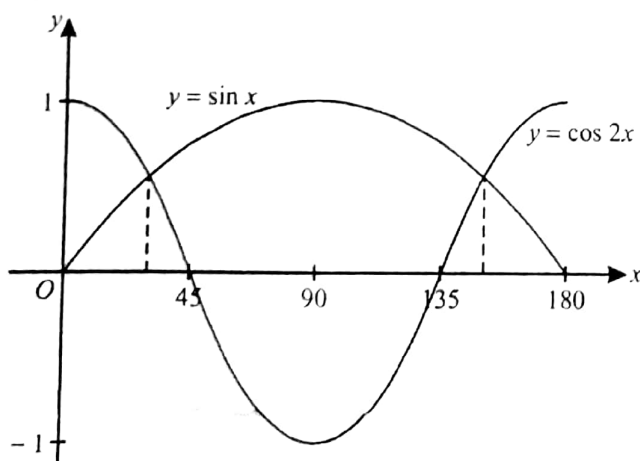

(ii)  $\sin 30^\circ = \frac{1}{2}$ , and  $\cos 2(30^\circ) = \frac{1}{2}$

From graph,  $x = 150^\circ$  is the other root,

(iii) From graph, for  $\sin x < \cos 2x$ ,  
 $0^\circ \leq x < 30^\circ$ , and  $150^\circ < x \leq 180^\circ$ .

36. (i)  $3 \sin^2 x - 8 \cos x - 7 = 0$   
 $\Rightarrow 3(1 - \cos^2 x) - 8 \cos x - 7 = 0$   
 $\Rightarrow 3 \cos^2 x + 8 \cos x + 4 = 0$   
 $\Rightarrow (3 \cos x + 2)(\cos x + 2) = 0$   
 $\therefore \cos x = -\frac{2}{3}$

(ii)  $3 \sin^2(\theta + 70^\circ) - 8 \cos(\theta + 70^\circ) - 7 = 0$   
 $\Rightarrow \cos(\theta + 70^\circ) = -\frac{2}{3}$   
 $\Rightarrow \theta + 70^\circ = 131.8^\circ, 228.2^\circ$   
 $\Rightarrow \theta = 61.8^\circ, 158.2^\circ$

37.  $\sin 2x = 2 \cos 2x \Rightarrow \tan 2x = 2$   
 $\Rightarrow 2x = 63.4, 243.4 \Rightarrow x = 31.7^\circ, 121.7^\circ$

38. (i) L.H.S. =  $\tan x + \frac{1}{\tan x}$   
 $= \frac{\sin x}{\cos x} + \frac{\cos x}{\sin x}$   
 $= \frac{\sin^2 x + \cos^2 x}{\sin x \cos x} = \frac{1}{\sin x \cos x}$

(ii)  $\frac{2}{\sin x \cos x} = 1 + 3 \tan x$ ,  
 $\Rightarrow 2 \left( \tan x + \frac{1}{\tan x} \right) = 1 + 3 \tan x$   
 $\Rightarrow \tan^2 x + \tan x - 2 = 0$   
 $\Rightarrow (\tan x + 2)(\tan x - 1) = 0$   
 $\Rightarrow \tan x = -2$  or  $\tan x = 1$   
 $\therefore x = 45^\circ, 116.6^\circ$

39. (i) L.H.S. =  $\tan^2 \theta - \sin^2 \theta$   
 $= \frac{\sin^2 \theta}{\cos^2 \theta} - \sin^2 \theta$   
 $= \sin^2 \theta \left( \frac{1}{\cos^2 \theta} - 1 \right)$   
 $= \sin^2 \theta \left( \frac{1 - \cos^2 \theta}{\cos^2 \theta} \right) = \tan^2 \theta \sin^2 \theta$

(ii) Since,  $\tan^2 \theta - \sin^2 \theta = \tan^2 \theta \sin^2 \theta$   
 $\Rightarrow \tan^2 \theta - \sin^2 \theta > 0$   
 $\Rightarrow \tan^2 \theta > \sin^2 \theta$   
 $\Rightarrow \tan \theta > \sin \theta$  for  $0^\circ < \theta < 90^\circ$ .

40. (i)  $\sin 2x + 3 \cos 2x = 0 \Rightarrow \tan 2x = -3$   
 $\Rightarrow 2x = 108.4^\circ, 288.4^\circ, 468.4^\circ, 648.4^\circ$   
 $\Rightarrow x = 54.2^\circ, 144.2^\circ, 234.2^\circ, 324.2^\circ$

41. (i)  $2\cos^2 \theta = 3\sin \theta$   
 $\Rightarrow 2\sin^2 \theta + 3\sin \theta - 2 = 0$   
 $\Rightarrow (2\sin \theta - 1)(\sin \theta + 2)$   
 $\Rightarrow \theta = 30^\circ \text{ or } 150^\circ$

(ii) Smallest positive value of  $\theta = 10^\circ$   
 $\Rightarrow n\theta = 30^\circ \Rightarrow n = \frac{30}{10} = 3$   
 For largest solution of  $\theta$ ,  
 $3\theta = 720^\circ + 150^\circ \Rightarrow \theta = \frac{870^\circ}{3} = 290^\circ$

42. (i)  $2\cos x = 3\tan x$   
 $\Rightarrow 2\cos x = 3\left(\frac{\sin x}{\cos x}\right)$   
 $\Rightarrow 2\cos^2 x = 3\sin x$   
 $\Rightarrow 2(1 - \sin^2 x) = 3\sin x$   
 $\Rightarrow 2\sin^2 x + 3\sin x - 2 = 0$

(ii)  $2\cos 2y = 3\tan 2y$   
 $\Rightarrow 2\sin^2 2y + 3\sin 2y - 2 = 0$   
 $\Rightarrow (2\sin 2y - 1)(\sin 2y + 2) = 0$   
 $\Rightarrow y = 15^\circ, 75^\circ$

43.  $7\cos x + 5 = 2\sin^2 x$   
 $\Rightarrow 2\cos^2 x + 7\cos x + 3 = 0$   
 $\Rightarrow (2\cos x + 1)(\cos x + 3) = 0$   
 $\Rightarrow x = 120^\circ, 240^\circ$

44. (i) L.H.S.  $= \frac{\sin \theta}{\sin \theta + \cos \theta} + \frac{\cos \theta}{\sin \theta - \cos \theta}$   
 $= \frac{\sin \theta(\sin \theta - \cos \theta) + \cos \theta(\sin \theta + \cos \theta)}{(\sin \theta + \cos \theta)(\sin \theta - \cos \theta)}$   
 $= \frac{1}{\sin^2 \theta - \cos^2 \theta}$

(ii)  $\frac{1}{\sin^2 \theta - \cos^2 \theta} = 3$   
 $\Rightarrow \frac{1}{1 - 2\cos^2 \theta} = 3$   
 $\Rightarrow \cos^2 \theta = \frac{1}{3} \Rightarrow \cos \theta = \pm \frac{1}{\sqrt{3}}$   
 $\Rightarrow \theta = 54.7, 125.3^\circ, 234.7^\circ, 305.3^\circ$

45. (i)  $a^2 + b^2$   
 $= (\sin \theta - 3\cos \theta)^2 + (3\sin \theta + \cos \theta)^2$   
 $= \sin^2 \theta - 6\sin \theta \cos \theta + 9\cos^2 \theta + 9\sin^2 \theta$   
 $= 10(\sin^2 \theta - 3\sin \theta \cos \theta + 3\cos^2 \theta)$

(ii)  $2a = b$   
 $\Rightarrow 2(\sin \theta - 3\cos \theta) = 3\sin \theta + \cos \theta$   
 $\Rightarrow -\sin \theta = 7\cos \theta \Rightarrow \tan \theta = -7$   
 $\therefore \theta = 98.1^\circ, 278.1^\circ$

46. (i)  $2\cos^2 \theta = \tan^2 \theta$   
 $\Rightarrow 2\cos^2 \theta = \frac{\sin^2 \theta}{\cos^2 \theta}$   
 $\Rightarrow 2\cos^4 \theta + \cos^2 \theta - 1 = 0$

(ii) From (i),  $2\cos^4 \theta + \cos^2 \theta - 1 = 0$   
 $\Rightarrow (2\cos^2 \theta - 1)(\cos^2 \theta + 1) = 0$   
 $\Rightarrow \cos^2 \theta = \frac{1}{2} \Rightarrow \cos \theta = \pm \frac{1}{\sqrt{2}}$   
 $\Rightarrow \theta = \frac{\pi}{4}, \frac{3\pi}{4}$

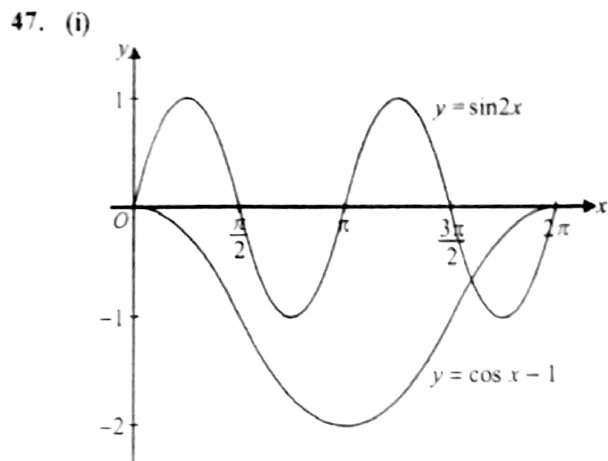

(ii) (a)  $2\sin 2x + 1 = 0$   
 $\Rightarrow \sin 2x = -\frac{1}{2} \Rightarrow y = -\frac{1}{2}$   
 $\therefore$  From graph, number of solutions = 4

(b)  $\sin 2x - \cos x + 1 = 0$   
 $\Rightarrow \sin 2x = \cos x - 1$   
 $\therefore$  From graph, number of solutions = 3

48. (i)  $4\sin^2 x + 8\cos x - 7 = 0$   
 $\Rightarrow 4\cos^2 x - 8\cos x + 3 = 0$   
 $\Rightarrow (2\cos x - 1)(2\cos x - 3) = 0$   
 $\Rightarrow \cos x = \frac{1}{2} \text{ or } \cos x = \frac{3}{2}$  (ignore)  
 $\Rightarrow x = 60^\circ \text{ or } 300^\circ$

(ii) From (i),  $x = 60^\circ$   
 $\Rightarrow \frac{1}{2}\theta = 60^\circ \Rightarrow \theta = 120^\circ$



49. (i)  $\sin x = \sqrt{1-p^2}$   
 (ii)  $\tan x = \frac{\sqrt{1-p^2}}{p}$   
 (iii)  $\tan(90^\circ - x) = \cot x = \frac{p}{\sqrt{1-p^2}}$

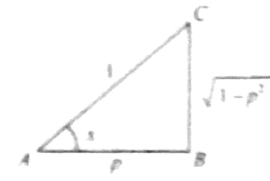

50. (i)  $x^2 - 1 = \sin(\frac{1}{3}\pi)$   
 $\Rightarrow x^2 = 1 + \frac{\sqrt{3}}{2} \Rightarrow x = \pm 1.366$

(ii)  $2\theta + \frac{1}{3}\pi = \frac{1}{6}\pi, \frac{5}{6}\pi$   
 $\Rightarrow \theta = \frac{\pi}{4}, \frac{11\pi}{12}$

51.  $a = 1, b = 2$

52. (i) L.H.S. =  $\frac{\sin \theta}{1 - \cos \theta} - \frac{1}{\sin \theta}$   
 $= \frac{\sin^2 \theta - 1 + \cos \theta}{\sin \theta(1 - \cos \theta)}$   
 $= \frac{(1 - \cos^2 \theta) - 1 + \cos \theta}{\sin \theta(1 - \cos \theta)}$   
 $= \frac{\cos(1 - \cos \theta)}{\sin \theta(1 - \cos \theta)} = \frac{1}{\tan \theta}$

(ii)  $\frac{1}{\tan \theta} = 4 \tan \theta \Rightarrow \tan \theta = \pm \frac{1}{2}$   
 $\Rightarrow \theta = 26.6^\circ, 153.4^\circ$

53. (i) Since,  $0 < k < 1$ , therefore acute angle  $\alpha$  lies in the 4th quadrant.

(a)  $\sin \theta = -\sin \alpha = -\sqrt{1-k^2}$   
 (b)  $\tan \theta = -\tan \alpha = \frac{-\sqrt{1-k^2}}{k}$

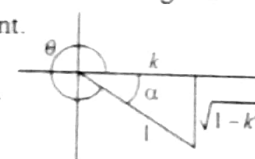

(ii)  $\theta$  lies in the 4th quadrant, i.e.  $270^\circ < \theta < 360^\circ$   
 $\Rightarrow 540^\circ \leq 2\theta \leq 720^\circ$   
 which is 3rd and 4th quadrant.  
 $\sin 2\theta$  is negative in both these quadrants.

54. (i) L.H.S. =  $\frac{1}{\cos \theta} - \frac{\cos \theta}{1 + \sin \theta}$   
 $= \frac{1 + \sin \theta - \cos^2 \theta}{\cos \theta(1 + \sin \theta)}$   
 $= \frac{\sin \theta + \sin^2 \theta}{\cos \theta(1 + \sin \theta)}$   
 $= \frac{\sin \theta(1 + \sin \theta)}{\cos \theta(1 + \sin \theta)} = \tan \theta$

(ii)  $\tan \theta + 2 = 0 \Rightarrow \tan \theta = -2$   
 $\therefore \theta = 116.6^\circ, 296.6^\circ$

55. (i) L.H.S. =  $\frac{\tan x + 1}{\sin x \tan x + \cos x}$   
 $= \frac{\frac{\sin x + \cos x}{\cos x}}{\frac{\sin^2 x}{\cos x} + \cos x}$   
 $= \frac{\sin x + \cos x}{\sin^2 x + \cos^2 x} = \sin x + \cos x$

(ii)  $\sin x + \cos x = 3 \sin x - 2 \cos x$   
 $\Rightarrow 2 \sin x = 3 \cos x \Rightarrow \tan x = \frac{3}{2}$   
 $\therefore x = 0.983, 4.124$

56.  $\sin^{-1}(x-1) = \tan^{-1}(3)$   
 $\Rightarrow \sin^{-1}(x-1) = 71.6$   
 $\Rightarrow (x-1) = 0.949 \Rightarrow x = 1.95$

57.  $\frac{13 \sin^2 \theta}{2 + \cos \theta} + \cos \theta = 2$   
 $\Rightarrow 13 \sin^2 \theta + 2 \cos \theta + \cos^2 \theta = 4 + 2 \cos \theta$   
 $\Rightarrow 13 \sin^2 \theta + (1 - \sin^2 \theta) = 4$   
 $\Rightarrow \sin^2 \theta = \frac{1}{4} \Rightarrow \sin \theta = \pm \frac{1}{2}$   
 $\theta = 30^\circ, 150^\circ$  Ans.

58. (i)  $1 + \sin x \tan x = 5 \cos x$   
 $\Rightarrow 1 + \frac{\sin^2 x}{\cos x} = 5 \cos x$   
 $\Rightarrow \cos x + \sin^2 x = 5 \cos^2 x$   
 $\Rightarrow 6 \cos^2 x - \cos x - 1 = 0$   
 (ii)  $6 \cos^2 x - \cos x - 1 = 0$   
 $\Rightarrow (2 \cos x - 1)(3 \cos x + 1) = 0$   
 $\Rightarrow \cos x = \frac{1}{2}$  or  $\cos x = -\frac{1}{3}$   
 $\therefore x = 60^\circ, 109.5^\circ$

59. (i)  $\sin^4 \theta - \cos^4 \theta$   
 $= (\sin^2 \theta - \cos^2 \theta)(\sin^2 \theta + \cos^2 \theta)$   
 $= \sin^2 \theta - (1 - \sin^2 \theta) = 2\sin^2 \theta - 1$

(ii)  $2\sin^2 \theta - 1 = \frac{1}{2}$   
 $\Rightarrow \sin^2 \theta = \frac{3}{4} \Rightarrow \sin \theta = \pm \frac{\sqrt{3}}{2}$   
 $\theta = 60^\circ, 120^\circ, 240^\circ, 300^\circ$

60. The associated acute angle  $\alpha$  lies in the 2nd quadrant.

(i)  $\cos \theta = -\cos \alpha$   
 $= -\sqrt{1-k^2}$

(ii)  $\tan \theta = -\tan \alpha$   
 $= -\frac{k}{\sqrt{1-k^2}}$

(iii)  $\sin(\theta + \pi) = -k$

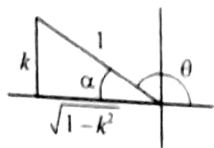

61. (i) L.H.S.  $= \frac{\sin \theta - \cos \theta}{\sin \theta + \cos \theta}$   
 Divide numerator & denominator by  $\cos \theta$

$$= \frac{\frac{\sin \theta}{\cos \theta} - \frac{\cos \theta}{\cos \theta}}{\frac{\sin \theta}{\cos \theta} + \frac{\cos \theta}{\cos \theta}} = \frac{\tan \theta - 1}{\tan \theta + 1}$$

(ii)  $\frac{\tan \theta - 1}{\tan \theta + 1} = \frac{\tan \theta}{6}$   
 $\Rightarrow 6(\tan \theta - 1) = \tan \theta(\tan \theta + 1)$   
 $\Rightarrow \tan^2 \theta - 5 \tan \theta + 6 = 0$   
 $\Rightarrow (\tan \theta - 3)(\tan \theta - 2) = 0$   
 $\Rightarrow \tan \theta = 3$  or  $\tan \theta = 2$   
 $\therefore \theta = 63.4^\circ, 71.6^\circ$

62. (i) Height is greatest when  $\cos kt$  is least i.e.  $-1$   
 $\therefore$  greatest height,  $h = 60(1 - (-1)) = 120$  m

(ii) When  $t = 30$  minutes, angle  $kt = 2\pi$  radians,  
 $\Rightarrow k(30) = 2\pi \Rightarrow k = \frac{\pi}{15}$

(iii)  $90 = 60(1 - \cos \frac{\pi}{15} t)$   
 $\Rightarrow \cos \frac{\pi}{15} t = 1 - \frac{90}{60} \Rightarrow \cos \frac{\pi}{15} t = -\frac{1}{2}$   
 $\Rightarrow \frac{\pi}{15} t = \frac{2\pi}{3}$ , or  $\frac{4\pi}{3}$   
 $\Rightarrow t = 10$  min. or  $t = 20$  min.  
 $\therefore$  time for which passenger is above 90 m  
 $= 20 - 10 = 10$  minutes

63. (i)  $3\sin \theta = \cos \theta$   
 $\Rightarrow \tan \theta = \frac{1}{3} \Rightarrow \theta = 18.4^\circ$

(ii)  $3\sin^2 2x = \cos^2 2x$   
 $\Rightarrow \tan^2 2x = \frac{1}{3} \Rightarrow \tan 2x = \pm \frac{1}{\sqrt{3}}$   
 $\Rightarrow 2x = 30^\circ, 150^\circ, 210^\circ, 330^\circ$   
 $\therefore x = 15^\circ, 75^\circ, 105^\circ, 165^\circ$

64. (i)  $\frac{4\cos \theta}{\frac{\sin \theta}{\cos \theta}} + 15 = 0 \Rightarrow \frac{4\cos^2 \theta}{\sin \theta} + 15 = 0$

$$\Rightarrow 4\cos^2 \theta + 15\sin \theta = 0$$

$$\Rightarrow 4\sin^2 \theta - 15\sin \theta - 4 = 0$$

(ii)  $4\sin^2 \theta - 15\sin \theta - 4 = 0$   
 $\Rightarrow (4\sin \theta + 1)(\sin \theta - 4) = 0$   
 $\Rightarrow \sin \theta = -\frac{1}{4}$  or  $\sin \theta = 4$  (ignore)  
 $\Rightarrow \theta = 194.5^\circ, 345.5^\circ$

65. (i) L.H.S.  $= \left( \frac{1}{\sin x} - \frac{1}{\tan x} \right)^2$   
 $= \left( \frac{1}{\sin x} - \frac{\cos x}{\sin x} \right)^2$   
 $= \frac{(1 - \cos x)^2}{\sin^2 x}$   
 $= \frac{(1 - \cos x)^2}{1 - \cos^2 x}$   
 $= \frac{(1 - \cos x)^2}{(1 - \cos x)(1 + \cos x)} = \frac{1 - \cos x}{1 + \cos x}$

(ii)  $\frac{1 - \cos x}{1 + \cos x} = \frac{2}{5}$   
 $\Rightarrow 2 + 2\cos x = 5 - 5\cos x \Rightarrow \cos x = \frac{3}{7}$   
 $\therefore x = 1.13$  radians,  $5.15$  radians.

66. (a)  $\frac{1}{\cos \theta} + 3\sin \theta \tan \theta + 4 = 0$   
 $\Rightarrow \frac{1}{\cos \theta} + \frac{3\sin^2 \theta}{\cos \theta} + 4 = 0$   
 $\Rightarrow 1 + 3\sin^2 \theta + 4\cos \theta = 0$   
 $\Rightarrow 3\cos^2 \theta - 4\cos \theta - 4 = 0$   
 Hence,  $(3\cos \theta + 2)(\cos \theta - 2) = 0$   
 $\Rightarrow \cos \theta = -\frac{2}{3}$  or  $\cos \theta = 2$  (impossible)  
 $\Rightarrow \theta = 131.8^\circ$ , or  $228.2^\circ$

(b) Subst. points C and D into

AL Mathematics (P1)

67.  $3\sin^2 \theta = 4\cos \theta - 1$   
 $\Rightarrow 3\cos^2 \theta + 4\cos \theta - 4 = 0$   
 $\Rightarrow (3\cos \theta - 2)(\cos \theta + 2) = 0$   
 $\Rightarrow \cos \theta = +\frac{2}{3}$  or  $\cos \theta = -2$  (ignore)  
 $\Rightarrow \theta = 48.2^\circ$ , or  $311.8^\circ$

68. (i) In  $\triangle ABC$ ,  $\tan \frac{\pi}{3} = \frac{AC}{2x} \Rightarrow AC = 2x\sqrt{3}$   
 In  $\triangle AMC$ , using pythagoras,  $AM = x\sqrt{13}$

(ii) In  $\triangle AMC$ ,  
 $\tan \hat{M}AC = \frac{x}{2x\sqrt{3}} \Rightarrow \hat{M}AC = \tan^{-1}\left(\frac{1}{2\sqrt{3}}\right)$   
 In  $\triangle ABC$ ,  
 $\theta + \frac{1}{3}\pi + \tan^{-1}\left(\frac{1}{2\sqrt{3}}\right) = \frac{1}{2}\pi$   
 $\Rightarrow \theta = \frac{1}{6}\pi - \tan^{-1}\left(\frac{1}{2\sqrt{3}}\right)$

69. (i)  $\frac{1+\cos \theta}{1-\cos \theta} - \frac{1-\cos \theta}{1+\cos \theta}$   
 $= \frac{(1+\cos \theta)^2 - (1-\cos \theta)^2}{(1-\cos \theta)(1+\cos \theta)}$   
 $= \frac{1+2\cos \theta + \cos^2 \theta - 1 + 2\cos \theta - \cos^2 \theta}{\sin^2 \theta}$   
 $= \frac{4\cos \theta}{\sin^2 \theta} = \frac{4}{\sin \theta \left(\frac{\sin \theta}{\cos \theta}\right)} = \frac{4}{\sin \theta \tan \theta}$

(ii)  $\sin \theta \left(\frac{4}{\sin \theta \tan \theta}\right) = 3$   
 $\Rightarrow \frac{4}{\tan \theta} = 3 \Rightarrow \tan \theta = \frac{4}{3}$   
 $\therefore \theta = 53.1^\circ, 233.1^\circ$

70. (i)  $3\sin x \tan x - \cos x + 1 = 0$   
 $\Rightarrow \frac{3\sin^2 x}{\cos x} - \cos x + 1 = 0$   
 $\Rightarrow 3(1 - \cos^2 x) - \cos^2 x + \cos x = 0$   
 $\Rightarrow 4\cos^2 x - \cos x - 3 = 0$   
 $\Rightarrow (4\cos x + 3)(\cos x - 1) = 0$   
 $\Rightarrow \cos x = -\frac{3}{4}$  or  $\cos x = 1$   
 $\therefore x = 2.419$ , or  $0$  radians.

(ii) Replacing angle  $x$  by  $2x$ , we have,  
 $\Rightarrow \cos 2x = -\frac{3}{4}$  or  $\cos 2x = 1$   
 $\Rightarrow 2x = 2.419, 3.864, 0, 2\pi$   
 $\therefore x = 1.21, 1.93, 0, \pi$  radians.

71. (i) L.H.S.  $\equiv \cos^4 x$   
 $= (1 - \sin^2 x)^2$   
 $= 1 - 2\sin^2 x + \sin^4 x$

(ii)  $8\sin^4 x + \cos^4 x = 2\cos^2 x$   
 $\Rightarrow 8\sin^4 x + (1 - 2\sin^2 x + \sin^4 x)$   
 $= 2(1 - \sin^2 x)$   
 $\Rightarrow \sin^4 x = \frac{1}{9} \Rightarrow \sin x = \pm \frac{1}{\sqrt{3}}$   
 $\therefore x = 35.3^\circ, 144.7^\circ, 215.3^\circ, 324.7^\circ$

72. (i)  $\sin 2x + 3\cos 2x = 3(\sin 2x - \cos 2x)$   
 divide throughout by  $\cos 2x$ ,  
 $\frac{\sin 2x}{\cos 2x} + \frac{3\cos 2x}{\cos 2x} = 3\left(\frac{\sin 2x}{\cos 2x} - \frac{\cos 2x}{\cos 2x}\right)$   
 $\tan 2x + 3 = 3(\tan 2x - 1)$   
 $\tan 2x = 3$

(ii)  $\tan 2x = 3$   
 $\Rightarrow 2x = -108.4^\circ, 71.6^\circ$   
 $\Rightarrow x = -54.2^\circ, 35.8^\circ$

73.  $6\sin^2 x - 5\cos^2 x = 2\sin^2 x + \cos^2 x$   
 $\Rightarrow 4\sin^2 x = 6\cos^2 x$   
 $\Rightarrow \tan^2 x = \frac{3}{2} \Rightarrow \tan x = \pm \sqrt{\frac{3}{2}}$   
 $\therefore x = 50.8^\circ, 129.2^\circ, 230.8^\circ, 309.2^\circ$

17/5/17

Online Classes: Megalecture@gmail.com  
www.youtube.com/megalecture  
R-N  
www.megalecture.com

Only Q numbering.

# TOPIC 7

## Binomial Expansion

4. The first three terms in the expansion of  $(2 + ax)^n$ , in ascending powers of  $x$ , are  $32 - 40x + bx^2$ . Find the values of the constants  $n$ ,  $a$  and  $b$ . [J06/P12/Q4]
5. Find the coefficient of  $x^2$  in the expansion of  $\left(x + \frac{2}{x}\right)^6$ . [N06/P12/Q1]
6. (i) Find the first three terms in the expansion of  $(2 + u)^5$  in ascending powers of  $u$ .  
(ii) Use the substitution  $u = x + x^2$  in your answer to part (i) to find the coefficient of  $x^2$  in the expansion of  $(2 + x + x^2)^5$ . [N07/P12/Q3]
7. (i) Find the first 3 terms in the expansion, in ascending powers of  $x$ , of  $(2 + x^2)^5$ .  
(ii) Hence find the coefficient of  $x^4$  in the expansion of  $(1 + x^2)^2 (2 + x^2)^5$ . [J08/P12/Q3]
8. Find the value of the coefficient of  $x^2$  in the expansion of  $\left(\frac{x}{2} + \frac{2}{x}\right)^6$ . [N08/P12/Q1]
9. (i) Find the first 3 terms in the expansion of  $(2 + 3x)^5$  in ascending powers of  $x$ .  
(ii) Hence find the value of the constant  $a$  for which there is no term in  $x^2$  in the expansion of  $(1 + ax)(2 + 3x)^5$ . [J09/P12/Q3]
10. (i) Find the first 3 terms in the expansion of  $(2 - x)^6$  in ascending powers of  $x$ .  
(ii) Given that the coefficient of  $x^2$  in the expansion of  $(1 + 2x + ax^2)(2 - x)^6$  is 48, find the value of the constant  $a$ . [N09/P11/Q3]
11. (i) Find, in terms of the non-zero constant  $k$ , the first 4 terms in the expansion of  $(k + x)^8$  in ascending powers of  $x$ .  
(ii) Given that the coefficients of  $x^2$  and  $x^3$  in this expansion are equal, find the value of  $k$ . [N09/P12/Q2]
12. (i) Find the first 3 terms in the expansion of  $\left(2x - \frac{3}{x}\right)^5$  in descending powers of  $x$ .  
(ii) Hence find the coefficient of  $x$  in the expansion of  $\left(1 + \frac{2}{x^2}\right)\left(2x - \frac{3}{x}\right)^5$ . [J10/P11/Q2]

13. (i) Find the first 3 terms in the expansion of  $(1+ax)^5$  in ascending powers of  $x$ .  
 (ii) Given that there is no term in  $x$  in the expansion of  $(1-2x)(1+ax)^5$ , find the value of the constant  $a$ .  
 (iii) For this value of  $a$ , find the coefficient of  $x^2$  in the expansion of  $(1-2x)(1+ax)^5$ . [J10/P12/Q6]
14. (i) Find the first three terms, in descending powers of  $x$ , in the expansion of  $\left(x-\frac{2}{x}\right)^6$ .  
 (ii) Find the coefficient of  $x^4$  in the expansion of  $\left(1+x^2\right)\left(x-\frac{2}{x}\right)^6$ . [J10/P13/Q2]
15. In the expansion of  $(1+ax)^6$ , where  $a$  is a constant, the coefficient of  $x$  is  $-30$ . Find the coefficient of  $x^3$ . [N10/P11/Q2]
16. (i) Find the first 3 terms in the expansion, in ascending powers of  $x$ , of  $(1-2x^2)^8$ .  
 (ii) Find the coefficient of  $x^4$  in the expansion of  $(2-x^2)(1-2x^2)^8$ . [N10/P12/Q1]
17. Find the term independent of  $x$  in the expansion of  $\left(x-\frac{1}{x^2}\right)^9$ . [N10/P13/Q1]
18. Find the coefficient of  $x$  in the expansion of  $\left(x+\frac{2}{x^2}\right)^7$ . [J11/P11/Q1]
19. (i) Find the terms in  $x^2$  and  $x^3$  in the expansion of  $\left(1-\frac{3}{2}x\right)^6$ .  
 (ii) Given that there is no term in  $x^3$  in the expansion of  $(k+2x)\left(1-\frac{3}{2}x\right)^6$ , find the value of the constant  $k$ . [J11/P12/Q2]
20. The coefficient of  $x^3$  in the expansion of  $(a+x)^5+(1-2x)^6$ , where  $a$  is positive, is 90. Find the value of  $a$ . [J11/P13/Q1]
21. Find the term independent of  $x$  in the expansion of  $\left(2x+\frac{1}{x^2}\right)^6$ . [N11/P11/Q1]
22. (i) Find the first 3 terms in the expansion of  $(2-y)^5$  in ascending powers of  $y$ .  
 (ii) Use the result in part (i) to find the coefficient of  $x^2$  in the expansion of  $(2-(2x-x^2))^5$ . [N11/P12/Q1]
23. The coefficient of  $x^2$  in the expansion of  $\left(k+\frac{1}{3}x\right)^5$  is 30. Find the value of the constant  $k$ . [N11/P13/Q1]



24. Find the coefficient of  $x^6$  in the expansion of  $\left(2x^3 - \frac{1}{x^2}\right)^7$  [J12/P11/Q2]

25. The coefficient of  $x^3$  in the expansion of  $(a + x)^5 + (2 - x)^5$  is 90. Find the value of the positive constant  $a$ . [J12/P12/Q3]

26. The first three terms in the expansion of  $(1 - 2x)^2(1 + ax)^6$ , in ascending powers of  $x$ , are  $1 - x + bx^2$ . Find the values of the constants  $a$  and  $b$ . [J12/P13/Q3]

27. (i) Find the first 3 terms in the expansion of  $(2x - x^2)^6$  in ascending powers of  $x$ .  
(ii) Hence find the coefficient of  $x^5$  in the expansion of  $(2 + x)(2x - x^2)^6$ . [N12/P11/Q4]

28. In the expansion of  $\left(x^2 - \frac{a}{x}\right)^7$  the coefficient of  $x^5$  is  $-280$ . Find the value of the constant  $a$ . [N12/P12/Q1]

29. Find the coefficient of  $x^3$  in the expansion of  $\left(2 - \frac{1}{2}x\right)^7$ . [N12/P13/Q1]

30. (i) In the expression  $(1 - px)^6$ ,  $p$  is a non-zero constant. Find the first three terms when  $(1 - px)^6$  is expanded in ascending powers of  $x$ .  
(ii) It is given that the coefficient of  $x^2$  in the expansion of  $(1 - x)(1 - px)^6$  is zero. Find the value of  $p$ . [J13/P11/Q2]

31. Find the coefficient of  $x^2$  in the expansion of  
(i)  $\left(2x - \frac{1}{2x}\right)^6$ ,  
(ii)  $(1 + x^2)\left(2x - \frac{1}{2x}\right)^6$ . [J13/P12/Q2]

32. (i) Find the first three terms in the expansion of  $(2 + ax)^5$  in ascending powers of  $x$ .  
(ii) Given that the coefficient of  $x^2$  in the expansion of  $(1 + 2x)(2 + ax)^5$  is 240, find the possible values of  $a$ . [J13/P13/Q4]

33. (i) Find the first three terms when  $(2 + 3x)^6$  is expanded in ascending powers of  $x$ .  
(ii) In the expansion of  $(1 + ax)(2 + 3x)^6$ , the coefficient of  $x^2$  is zero. Find the value of  $a$ . [N13/P11/Q1]

34. (i) Find the coefficient of  $x^5$  in the expansion of  $(x + 3x^2)^4$ .  
(ii) Find the coefficient of  $x^5$  in the expansion of  $(x + 3x^2)^5$ .  
(iii) Hence find the coefficient of  $x^5$  in the expansion of  $[1 + (x + 3x^2)]^5$ . [N13/P13/Q8]

24. Find the coefficient of  $x^6$  in the expansion of  $\left(2x^3 - \frac{1}{x^2}\right)^7$ . [J12/P11/Q2]
25. The coefficient of  $x^3$  in the expansion of  $(a + x)^5 + (2 - x)^6$  is 90. Find the value of the positive constant  $a$ . [J12/P12/Q3]
26. The first three terms in the expansion of  $(1 - 2x)^2(1 + ax)^6$ , in ascending powers of  $x$ , are  $1 - x + bx^2$ . Find the values of the constants  $a$  and  $b$ . [J12/P13/Q3]
27. (i) Find the first 3 terms in the expansion of  $(2x - x^2)^6$  in ascending powers of  $x$ .  
 (ii) Hence find the coefficient of  $x^8$  in the expansion of  $(2 + x)(2x - x^2)^6$ . [N12/P11/Q4]
28. In the expansion of  $\left(x^2 - \frac{a}{x}\right)^7$  the coefficient of  $x^5$  is  $-280$ . Find the value of the constant  $a$ . [N12/P12/Q1]
29. Find the coefficient of  $x^3$  in the expansion of  $\left(2 - \frac{1}{2}x\right)^7$ . [N12/P13/Q1]
30. (i) In the expression  $(1 - px)^6$ ,  $p$  is a non-zero constant. Find the first three terms when  $(1 - px)^6$  is expanded in ascending powers of  $x$ .  
 (ii) It is given that the coefficient of  $x^2$  in the expansion of  $(1 - x)(1 - px)^6$  is zero. Find the value of  $p$ . [J13/P11/Q2]
31. Find the coefficient of  $x^2$  in the expansion of  
 (i)  $\left(2x - \frac{1}{2x}\right)^6$ ,  
 (ii)  $(1 + x^2)\left(2x - \frac{1}{2x}\right)^6$ . [J13/P12/Q2]
32. (i) Find the first three terms in the expansion of  $(2 + ax)^5$  in ascending powers of  $x$ .  
 (ii) Given that the coefficient of  $x^2$  in the expansion of  $(1 + 2x)(2 + ax)^5$  is 240, find the possible values of  $a$ . [J13/P13/Q4]
33. (i) Find the first three terms when  $(2 + 3x)^6$  is expanded in ascending powers of  $x$ .  
 (ii) In the expansion of  $(1 + ax)(2 + 3x)^6$ , the coefficient of  $x^2$  is zero. Find the value of  $a$ . [N13/P11/Q1]
34. (i) Find the coefficient of  $x^8$  in the expansion of  $(x + 3x^2)^4$ .  
 (ii) Find the coefficient of  $x^8$  in the expansion of  $(x + 3x^2)^5$ .  
 (iii) Hence find the coefficient of  $x^8$  in the expansion of  $[1 + (x + 3x^2)]^5$ . [N13/P13/Q8]

35. Find the term independent of  $x$  in the expansion of  $\left(4x^3 + \frac{1}{2x}\right)^8$ . [J14/P11/Q3]
36. Find the coefficient of  $x^2$  in the expansion of  $(1+x^2)\left(\frac{x}{2} - \frac{4}{x}\right)^6$ . [J14/P12/Q2]
37. Find the coefficient of  $x$  in the expansion of  $\left(x^2 - \frac{2}{x}\right)^5$ . [J14/P13/Q1]
38. In the expansion of  $(2+ax)^7$ , the coefficient of  $x$  is equal to the coefficient of  $x^2$ . Find the value of the non-zero constant  $a$ . [N14/P11/Q1]
39. (i) Find the first 3 terms, in ascending powers of  $x$ , in the expansion of  $(1+x)^5$ .  
The coefficient of  $x^2$  in the expansion of  $(1+(px+x^2))^5$  is 95.  
(ii) Use the answer to part (i) to find the value of the positive constant  $p$ . [N14/P12/Q3]
40. In the expansion of  $(2+ax)^6$ , the coefficient of  $x^2$  is equal to the coefficient of  $x^3$ . Find the value of the non-zero constant  $a$ . [N14/P13/Q1]
41. (i) Find the first three terms, in ascending powers of  $x$ , in the expansion of  
(a)  $(1-x)^6$ ,  
(b)  $(1+2x)^6$ .  
(ii) Hence find the coefficient of  $x^2$  in the expansion of  $[(1-x)(1+2x)]^6$ . [J15/P11/Q3]
42. (i) Find the coefficients of  $x^2$  and  $x^3$  in the expansion of  $(2-x)^6$ .  
(ii) Find the coefficient of  $x^3$  in the expansion of  $(3x+1)(2-x)^6$ . [J15/P12/Q3]
43. (i) Write down the first 4 terms, in ascending powers of  $x$ , of the expansion of  $(a-x)^5$ .  
(ii) The coefficient of  $x^3$  in the expansion of  $(1-ax)(a-x)^5$  is  $-200$ . Find the possible values of the constant  $a$ . [J15/P13/Q3]
44. In the expansion of  $\left(1 - \frac{2x}{a}\right)(a+x)^5$ , where  $a$  is a non-zero constant, show that the coefficient of  $x^2$  is zero. [N15/P11/Q1]
45. In the expansion of  $(x+2k)^7$ , where  $k$  is a non-zero constant, the coefficients of  $x^4$  and  $x^5$  are equal. Find the value of  $k$ . [N15/P12/Q2]

46. Find the coefficient of  $x$  in the expansion of  $\left(\frac{x}{3} + \frac{9}{x^2}\right)^7$ . [N15/P13/Q2]
47. Find the term independent of  $x$  in the expansion of  $\left(x - \frac{3}{2x}\right)^6$ . [J16/P11/Q1]
48. Find the term that is independent of  $x$  in the expansion of
- (i)  $\left(x - \frac{2}{x}\right)^6$ ,
- (ii)  $\left(2 + \frac{3}{x^2}\right)\left(x - \frac{2}{x}\right)^6$ . [J16/P12/Q4]
49. Find the coefficient of  $x$  in the expansion of  $\left(\frac{1}{x} + 3x^2\right)^5$ . [J16/P13/Q1]
50. Find the term independent of  $x$  in the expansion of  $\left(2x + \frac{1}{2x^3}\right)^8$ . [N16/P11/Q2]
51. In the expansion of  $(3 - 2x)\left(1 + \frac{x}{2}\right)^n$ , the coefficient of  $x$  is 7. Find the value of the constant  $n$  and hence find the coefficient of  $x^2$ . [N16/P12/Q4]
52. The coefficient of  $x^3$  in the expansion of  $(1 - 3x)^6 + (1 + ax)^5$  is 100. Find the value of the constant  $a$ . [N16/P13/Q2]

**ANSWERS**

**Topic 7 - Binomial Expansion**

4.  $2^n + n(2)^{n-1}(ax) + \frac{n(n-1)}{2!}(2)^{n-2}(ax)^2$   
 $= 32 - 40x + bx^2$   
 comparing the co-efficients, we have,  
 $n = 5, a = -\frac{1}{2}, b = 20$
5.  $T_{r+1} = {}^6C_r (x)^{6-r} \left(\frac{2}{x}\right)^r = {}^6C_r (2)^r (x)^{6-2r}$   
 for  $x^2, r = 2, \therefore$  coefficient of  $x^2 = 60$
6. (i)  $(2+u)^5 = 32 + 80u + 80u^2$   
 (ii) Given substitution is:  $u = x + x^2$   
 $(2+x+x^2)^5 = 32 + 80(x+x^2) + 80(x+x^2)^2$   
 $= 32 + 80x + 160x^2 + 160x^3 + 80x^4$   
 $\therefore$  coefficient of  $x^2 = 160$
7. (i)  $32 + 80x^2 + 80x^4$   
 (ii)  $(1+x^2)^2(2+x^2)^5$   
 $= (1+2x^2+x^4)(32+80x^2+80x^4+\dots)$   
 collecting the terms containing  $x^4$  gives,  
 coefficient of  $x^4 = 272$
8.  $T_{r+1} = {}^6C_r \left(\frac{x}{2}\right)^{6-r} \left(\frac{2}{x}\right)^r$   
 for  $x^2, r = 2$   
 $\Rightarrow T_3 = 15 \left(\frac{x}{2}\right)^4 \left(\frac{2}{x}\right)^2 = \frac{15}{4}x^2$   
 $\therefore$  coefficient of  $x^2 = 3\frac{3}{4}$
9. (i)  $32 + 240x + 720x^2$   
 (ii)  $(1+ax)(32 + 240x + 720x^2)$   
 Terms containing  $x^2$  are,  $720x^2 + 240ax^2$   
 $\Rightarrow 720 + 240a = 0 \Rightarrow a = -3$
10. (i)  $64 - 192x + 240x^2$   
 (ii)  $(1+2x+ax^2)(64 - 192x + 240x^2 + \dots)$   
 $= \dots + 240x^2 - 384x^2 + 64ax^2 + \dots$   
 $\Rightarrow 240 - 384 + 64a = 48 \Rightarrow a = 3$
11. (i)  $k^8 + 8k^7x + 28k^6x^2 + 56k^5x^3$   
 (ii)  $28k^6 = 56k^5$   
 $\Rightarrow 28k^5(k-2) = 0 \Rightarrow k = 2$
12. (i)  $32x^5 - 240x^3 + 720x$   
 (ii)  $\left(1 + \frac{2}{x^2}\right)(32x^5 - 240x^3 + 720x)$   
 $= \dots - 480x + 720x + \dots$   
 $\Rightarrow$  coefficient of  $x = 240$
13. (i)  $1 + 5ax + 10a^2x^2$   
 (ii)  $(1-2x)(1 + 5ax + 10a^2x^2 + \dots)$   
 $= \dots + 5ax - 2x + \dots$   
 $\Rightarrow 5a - 2 = 0 \Rightarrow a = \frac{2}{5}$   
 (iii)  $(1-2x)(1 + 5ax + 10a^2x^2 + \dots)$   
 $= \dots + 10a^2x^2 - 10ax^2 + \dots$   
 coefficient of  $x^2 = 10\left(\frac{2}{5}\right)^2 - 10\left(\frac{2}{5}\right) = -2.4$
14. (i)  $x^6 - 12x^4 + 60x^2$   
 (ii)  $(1+x^2)(x^6 - 12x^4 + 60x^2)$   
 $= \dots - 12x^4 + 60x^4 + \dots$   
 $\therefore$  coefficient of  $x^4 = 48$
15.  $1 + 6ax + 15a^2x^2 + 20a^3x^3 + \dots$   
 $6a = -30 \Rightarrow a = -5$   
 $\therefore$  coefficient of  $x^3 = 20a^3 = -2500$
16. (i)  $1 - 16x^2 + 112x^4$   
 (ii)  $(2-x^2)(1 - 16x^2 + 112x^4)$   
 $= \dots + 224x^4 + 16x^4 + \dots$   
 $\therefore$  coefficient of  $x^4 = 240$
17.  $T_{r+1} = {}^9C_r (x)^{9-r} \left(-\frac{1}{x^2}\right)^r$   
 for term independent of  $x, r = 3$   
 $\Rightarrow T_4 = -84$



AL Mathematics (P1)

18.  $T_{r+1} = {}^7C_r (x)^{7-r} \left(\frac{2}{x^2}\right)^r$   
 for term in  $x$ , put  $r = 2$ ,  
 $\Rightarrow T_4 = 21(4x) = 84x$ ,  $\therefore$  coefficient of  $x = 84$
19. (i)  $\left(1 - \frac{3}{2}x\right)^6 = 1 - \frac{9}{2}x + \frac{135}{4}x^2 - \frac{540}{8}x^3 + \dots$   
 Terms in  $x^2$  and  $x^3$  are:  $\frac{135}{4}x^2$  and  $-\frac{540}{8}x^3$
- (ii)  $(k + 2x)\left(1 - \frac{9}{2}x + \frac{135}{4}x^2 - \frac{135}{2}x^3\right)$   
 Terms in  $x^3$  are,  $-\frac{135}{2}x^3k + \frac{135}{2}x^3$   
 $\Rightarrow -\frac{135}{2}k + \frac{135}{2} = 0 \Rightarrow k = 1$
20.  $(a + x)^5 + (1 - 2x)^6$   
 $= (a^5 + 5a^4x + 10a^3x^2 + 10a^2x^3 + \dots)$   
 $+ (1 - 12x + 60x^2 - 160x^3 + \dots)$   
 $= (\dots + 10a^2x^3 + \dots) + (\dots - 160x^3 + \dots)$   
 $\Rightarrow 10a^2 - 160 = 90 \Rightarrow a = 5$
21.  $T_{r+1} = {}^6C_r (2x)^{6-r} \left(\frac{1}{x^2}\right)^r$   
 for term independent of  $x$ ,  $r = 2$   
 $\Rightarrow T_3 = 15(15) = 240$
22. (i)  $(2 - y)^5 = 2^5 - 5(2)^4y + 10(2)^3y^2 + \dots$   
 $= 32 - 80y + 80y^2 + \dots$
- (ii) Substitute,  $y = 2x - x^2$  in (i),  
 $(2 - (2x - x^2))^5$   
 $= 32 - 80(2x - x^2) + 80(2x - x^2)^2$   
 $= \dots + 80x^2 + 320x^2 + \dots$   
 $\therefore$  coefficient of  $x^2 = 400$
23.  $\left(k + \frac{1}{3}x\right)^5 = k^5 + \frac{5}{3}xk^4 + \frac{10}{9}x^2k^3$   
 $\Rightarrow \frac{10}{9}k^3 = 30 \Rightarrow k = 3$
24.  $T_{r+1} = {}^7C_r (2x^3)^{7-r} \left(-\frac{1}{x^2}\right)^r$   
 for term in  $x^6$ ,  $r = 3$   
 $\Rightarrow T_4 = 35(-16x^6) = -560x^6$   
 coefficient of  $x^6 = -560$
25.  $(a + x)^5 + (2 - x)^6$   
 $= (a^5 + 5a^4x + 10a^3x^2 + 10a^2x^3 + \dots)$   
 $+ (64 - 192x + 240x^2 - 160x^3 + \dots)$   
 terms in  $x^3$  only are:  $10a^2x^3 - 160x^3$   
 $\Rightarrow 10a^2 - 160 = 90 \Rightarrow a = 5$
26.  $(1 - 2x)^2(1 + ax)^6$   
 $= (1 - 4x + 4x^2)(1 + 6ax + 15a^2x^2)$   
 $\Rightarrow 1 + (6a - 4)x + (15a^2 - 24a + 4)x^2 + \dots$   
 by comparing with  $1 - x + bx^2$ , we have,  
 $a = \frac{1}{2}$ ,  $b = -\frac{17}{4}$
27. (i)  $(2x - x^2)^6 = 64x^6 - 192x^7 + 240x^8$
- (ii)  $(2 + x)(64x^6 - 192x^7 + 240x^8 + \dots)$   
 $= \dots + 480x^8 - 192x^8 + \dots$   
 $\therefore$  coefficient of  $x^8 = 288$
28.  $\left(x^2 - \frac{a}{x}\right)^7 = x^{14} - 7ax^{11} + 21a^2x^8 - 35a^3x^5$   
 $\Rightarrow -35a^3 = -280 \Rightarrow a = 2$
29.  $\left(2 - \frac{1}{2}x\right)^7 = 2^7 - 224x + 168x^2 - 70x^3$   
 $\therefore$  coefficient of  $x^3 = -70$
30. (i)  $(1 - px)^6 = 1 - 6px + 15p^2x^2$
- (ii)  $(1 - x)(1 - 6px + 15p^2x^2)$   
 $= \dots + 15p^2x^2 + 6px^2 + \dots$   
 $\Rightarrow 15p^2 + 6p = 0 \Rightarrow p = -\frac{2}{5}$
31. (i)  $\left(2x - \frac{1}{2x}\right)^6 = 64x^6 - 96x^4 + 60x^2 - 20 + \dots$   
 $\therefore$  co-efficient of  $x^2 = 60$
- (ii)  $(1 + x^2)(64x^6 - 96x^4 + 60x^2 - 20 + \dots)$   
 $= \dots + 60x^2 - 20x^2 + \dots$   
 $\therefore$  coefficient of  $x^2 = 40$
32. (i)  $(2 + ax)^5 = 32 + 80ax + 80a^2x^2$
- (ii)  $(1 + 2x)(32 + 80ax + 80a^2x^2 + \dots)$   
 $= \dots + 80a^2x^2 + 160ax^2 + \dots$   
 $\Rightarrow 80a^2 + 160a = 240$   
 $\Rightarrow a^2 + 2a - 3 = 0 \Rightarrow a = -3$ , or 1

33. (i)  $(2+3x)^6 = 64 + 576x + 2160x^2$

(ii)  $(1+ax)(64 + 576x + 2160x^2)$   
 $= \dots + 2160x^2 + 576ax^2 + \dots$   
 $\Rightarrow 2160 + 576a = 0 \Rightarrow a = -3.75$

34. (i)  $(x+3x^2)^4 = x^4 + 12x^5 + 54x^6 + 108x^7 + 81x^8$   
 $\therefore$  coefficient of  $x^8 = 81$

(ii)  $(x+3x^2)^5 = x^5 + 15x^6 + 90x^7 + 270x^8$   
 $\therefore$  coefficient of  $x^8 = 270$

(iii)  $[1+(x+3x^2)]^5$   
 $= 1 + \dots + {}^5C_4(x+3x^2)^4 + {}^5C_5(x+3x^2)^5$   
 $= 1 + \dots + 5(81x^8) + 270x^8$   
 $\therefore$  coefficient of  $x^8 = 405 + 270 = 675$

35.  $T_{r+1} = {}^8C_r (4x^3)^{8-r} \left(\frac{1}{2x}\right)^r$   
 for term independent of  $x$ ,  $r = 6$   
 $\Rightarrow T_7 = 28(16) \left(\frac{1}{64}\right) = 7$

36.  $(1+x^2) \left(\frac{x}{2} - \frac{4}{x}\right)^6$   
 $= (1+x^2) \left[ \left(\frac{x}{2}\right)^6 - 6\left(\frac{x^4}{8}\right) + 15x^2 - 20(8) + \dots \right]$   
 $= \dots + 15x^2 - 160x^2 + \dots$   
 $\therefore$  coefficient of  $x^2 = -145$

37.  $\left(x^2 - \frac{2}{x}\right)^5 = x^{10} - 10x^7 + 40x^4 - 80x$   
 $\therefore$  coefficient of  $x = -80$

38.  $(2+ax)^7 = 128 + 448ax + 672a^2x^2 + \dots$   
 coefficient of  $x =$  coefficient of  $x^2$   
 $\Rightarrow 448a = 672a^2 \Rightarrow a = \frac{2}{3}$

39. (i)  $(1+x)^5 = 1 + 5x + 10x^2$   
 (ii)  $(1+(px+x^2))^5 = 1 + 5(px+x^2) + 10(px+x^2)^2$   
 terms in  $x^2$  only are:  $5x^2 + 10p^2x^2$   
 $\Rightarrow 5 + 10p^2 = 95 \Rightarrow p = 3$

40.  $(2+ax)^6 = 64 + 192ax + 240a^2x^2 + 160a^3x^3$   
 coefficient of  $x^2 =$  coefficient of  $x^3$   
 $\Rightarrow 240a^2 = 160a^3 \Rightarrow a = \frac{3}{2}$

41. (i) (a)  $(1-x)^6 = 1 - 6x + 15x^2$

(b)  $(1+2x)^6 = 1 + 12x + 60x^2$

(ii)  $[(1-x)(1+2x)]^6 = (1-x)^6(1+2x)^6$   
 $\Rightarrow (1-6x+15x^2)(1+12x+60x^2)$   
 $\Rightarrow \dots + 60x^2 - 72x^2 + 15x^2 + \dots$   
 $\Rightarrow$  coefficient of  $x^2 = 60 - 72 + 15 = 3$

42. (i)  $(2-x)^6 = 64 - 192x + 240x^2 - 160x^3 + \dots$   
 Coefficients of  $x^2$  and  $x^3$  are 240 and -160

(ii)  $(3x+1)(2-x)^6$   
 $= (3x+1)(64 - 192x + 240x^2 - 160x^3)$   
 the terms in  $x^3$  only are,  $720x^3 - 160x^3$   
 $\therefore$  coefficient of  $x^3 = 560$

43. (i)  $(a-x)^5 = a^5 - 5a^4x + 10a^3x^2 - 10a^2x^3 + \dots$

(ii)  $(1-ax)(a^5 - 5a^4x + 10a^3x^2 - 10a^2x^3 + \dots)$   
 $= \dots - 10a^2x^3 - 10a^4x^3 + \dots$   
 $\Rightarrow -10a^2 - 10a^4 = -200$   
 $\Rightarrow (a^2 - 4)(a^2 + 5) \Rightarrow a = \pm 2$

44.  $\left(1 - \frac{2x}{a}\right)(a+x)^5$   
 $= \left(1 - \frac{2x}{a}\right)(a^5 + 5a^4x + 10a^3x^2 + \dots)$   
 $= \dots + 10a^3x^2 - 10a^3x^2 + \dots$   
 $\Rightarrow 10a^3 - 10a^3 = 0$

45.  $(x+2k)^7 = (2k+x)^7$   
 Term in  $x^4 = {}^7C_4(2k)^{7-4}(x)^4 = 280k^3x^4$   
 Term in  $x^5 = {}^7C_5(2k)^{7-5}(x)^5 = 84k^2x^5$   
 Coefficient of  $x^4 =$  Coefficient of  $x^5$   
 $\Rightarrow 280k^3 = 84k^2 \Rightarrow k = \frac{3}{10}$

46.  $\left(\frac{x}{3} + \frac{9}{x^2}\right)^7$   
 $= \left(\frac{x}{3}\right)^7 + 7\left(\frac{x}{3}\right)^6\left(\frac{9}{x^2}\right) + 21\left(\frac{x}{3}\right)^5\left(\frac{9}{x^2}\right)^2 + \dots$   
 $\Rightarrow$  coefficient of  $x = 21\left(\frac{1}{3}\right)^5(9)^2 = 7$

47.  $T_{r+1} = {}^6C_r (x)^{6-r} \left(-\frac{3}{2x}\right)^r$

for term independent of  $x$ ,  $r = 3$

$\Rightarrow T_4 = 20 \left(-\frac{27}{8}\right) = -\frac{135}{2}$

48. (i)  $\left(x - \frac{2}{x}\right)^6 = x^6 - 12x^4 + 60x^2 - 160 + \dots$

$\therefore$  term independent of  $x = -160$

(ii)  $\left(2 + \frac{3}{x^2}\right)(x^6 - 12x^4 + 60x^2 - 160 + \dots)$

$= \dots - 320 + 180 + \dots$

$\therefore$  term independent of  $x = -140$

49.  $T_{r+1} = {}^5C_r \left(\frac{1}{x}\right)^{5-r} (3x^2)^r$

for term in  $x$ , put  $r = 2$

$\Rightarrow T_3 = 10(9x) = 90x \quad \therefore$  coefficient of  $x = 90$

50.  $T_{r+1} = {}^8C_r (2x)^{8-r} \left(\frac{1}{2x^3}\right)^r$

For term independent of  $x$ , put  $r = 2$

$\Rightarrow T_3 = 28(64)\left(\frac{1}{4}\right) = 448.$

51.  $(3-2x)\left(1+\frac{x}{2}\right)^n = (3-2x)\left(1+n\left(\frac{x}{2}\right) + {}^nC_2\left(\frac{x^2}{4}\right) + \dots\right)$

The terms in  $x$  only are,  $3n\left(\frac{x}{2}\right) - 2x$

$\Rightarrow \frac{3}{2}n - 2 = 7 \Rightarrow n = 6$

now, the terms in  $x^2$  are,  $3^n C_2 \left(\frac{x^2}{4}\right) - 2x\left(\frac{nx}{2}\right)$

$\Rightarrow 3^6 C_2 \left(\frac{x^2}{4}\right) - 6x^2 = \frac{45}{4}x^2 - 6x^2 = \frac{21}{4}x^2$

$\therefore$  coefficient of  $x^2 = \frac{21}{4}$

52.  $(1-3x)^6 + (1+ax)^5$

$(1-18x+135x^2-540x^3+\dots)$

$+ (1+5ax+10a^2x^2+10a^3x^3+\dots)$

$= (\dots - 540x^3 + \dots) + (\dots + 10a^3x^3 + \dots)$

$\Rightarrow -540 + 10a^3 = 100 \Rightarrow a = 4$

27/8/17

R-3110

Part 01

Q-Numbering

## TOPIC 8

# Arithmetic And Geometric Progressions

5. Each year a company gives a grant to a charity. The amount given each year increases by 5% of its value in the preceding year. The grant in 2001 was \$5000. Find
- (i) the grant given in 2011.
  - (ii) the total amount of money given to the charity during the years 2001 to 2011 inclusive.
- [J06/P12/Q3]
6. (a) Find the sum of all the integers between 100 and 400 that are divisible by 7.
- (b) The first three terms in a geometric progression are 144,  $x$  and 64 respectively, where  $x$  is positive. Find
- (i) the value of  $x$ ,
  - (ii) the sum to infinity of the progression.
- [N06/P12/Q6]
7. The second term of a geometric progression is 3 and the sum to infinity is 12.
- (i) Find the first term of the progression.
- An arithmetic progression has the same first and second terms as the geometric progression.
- (ii) Find the sum of the first 20 terms of the arithmetic progression.
- [J07/P12/Q7]
8. The 1st term of an arithmetic progression is  $a$  and the common difference is  $d$ , where  $d \neq 0$ .
- (i) Write down expressions, in terms of  $a$  and  $d$ , for the 5th term and the 15th term.
- The 1st term, the 5th term and the 15th term of the arithmetic progression are the first three terms of a geometric progression.
- (ii) Show that  $3a = 8d$ .
  - (iii) Find the common ratio of the geometric progression.
- [N07/P12/Q4]
9. The first term of a geometric progression is 81 and the fourth term is 24. Find
- (i) the common ratio of the progression,
  - (ii) the sum to infinity of the progression.
- The second and third terms of this geometric progression are the first and fourth terms respectively of an arithmetic progression.
- (iii) Find the sum of the first ten terms of the arithmetic progression.
- [J08/P12/Q7]
10. The first term of an arithmetic progression is 6 and the fifth term is 12. The progression has  $n$  terms and the sum of all the terms is 90. Find the value of  $n$ .
- [N08/P12/Q3]

11. (a) Find the sum to infinity of the geometric progression with first three terms  $0.5$ ,  $0.5^3$  and  $0.5^5$   
 (b) The first two terms in an arithmetic progression are  $5$  and  $9$ . The last term in the progression is the only term which is greater than  $200$ . Find the sum of all the terms in the progression. [J09/P12/Q7]
12. The first term of an arithmetic progression is  $8$  and the common difference is  $d$ , where  $d \neq 0$ . The first term, the fifth term and the eighth term of this arithmetic progression are the first term, the second term and the third term, respectively, of a geometric progression whose common ratio is  $r$ .  
 (i) Write down two equations connecting  $d$  and  $r$ . Hence show that  $r = \frac{3}{4}$  and find the value of  $d$ .  
 (ii) Find the sum to infinity of the geometric progression.  
 (iii) Find the sum of the first  $8$  terms of the arithmetic progression. [N09/P11/Q8]
13. A progression has a second term of  $96$  and a fourth term of  $54$ . Find the first term of the progression in each of the following cases:  
 (i) the progression is arithmetic,  
 (ii) the progression is geometric with a positive common ratio. [N09/P12/Q3]
14. The ninth term of an arithmetic progression is  $22$  and the sum of the first  $4$  terms is  $49$ .  
 (i) Find the first term of the progression and the common difference.  
 The  $n$ th term of the progression is  $46$ .  
 (ii) Find the value of  $n$ . [J10/P11/Q3]
15. (a) Find the sum of all the multiples of  $5$  between  $100$  and  $300$  inclusive.  
 (b) A geometric progression has a common ratio of  $-\frac{2}{3}$  and the sum of the first  $3$  terms is  $35$ . Find  
 (i) the first term of the progression,  
 (ii) the sum to infinity. [J10/P12/Q7]
16. The first term of a geometric progression is  $12$  and the second term is  $-6$ . Find  
 (i) the tenth term of the progression,  
 (ii) the sum to infinity. [J10/P13/Q1]
17. (a) The fifth term of an arithmetic progression is  $18$  and the sum of the first  $5$  terms is  $75$ . Find the first term and the common difference.  
 (b) The first term of a geometric progression is  $16$  and the fourth term is  $\frac{27}{4}$ . Find the sum to infinity of the progression. [N10/P11/Q6]
18. (a) The first and second terms of an arithmetic progression are  $161$  and  $154$  respectively. The sum of the first  $m$  terms is zero. Find the value of  $m$ .  
 (b) A geometric progression, in which all the terms are positive, has common ratio  $r$ . The sum of the first  $n$  terms is less than  $90\%$  of the sum to infinity. Show that  $r^n > 0.1$ . [N10/P12/Q5]



19. (a) A geometric progression has first term 100 and sum to infinity 2000. Find the second term.  
 (b) An arithmetic progression has third term 90 and fifth term 80.  
 (i) Find the first term and the common difference.  
 (ii) Find the value of  $m$  given that the sum of the first  $m$  terms is equal to the sum of the first  $(m + 1)$  terms.  
 (iii) Find the value of  $n$  given that the sum of the first  $n$  terms is zero. [N10/P13/Q9]
20. A television quiz show takes place every day. On day 1 the prize money is \$1000. If this is not won the prize money is increased for day 2. The prize money is increased in a similar way every day until it is won. The television company considered the following two different models for increasing the prize money.  
 Model 1: Increase the prize money by \$1000 each day.  
 Model 2: Increase the prize money by 10% each day.  
 On each day that the prize money is not won the television company makes a donation to charity. The amount donated is 5% of the value of the prize on that day. After 40 days the prize money has still not been won. Calculate the total amount donated to charity.  
 (i) if Model 1 is used,  
 (ii) if Model 2 is used. [J11/P11/Q8]
21. (a) A circle is divided into 6 sectors in such a way that the angles of the sectors are in arithmetic progression. The angle of the largest sector is 4 times the angle of the smallest sector. Given that the radius of the circle is 5 cm, find the perimeter of the smallest sector.  
 (b) The first, second and third terms of a geometric progression are  $2k + 3$ ,  $k + 6$  and  $k$ , respectively. Given that all the terms of the geometric progression are positive, calculate  
 (i) the value of the constant  $k$ ,  
 (ii) the sum to infinity of the progression. [J11/P12/Q10]
22. (a) A geometric progression has a third term of 20 and a sum to infinity which is three times the first term. Find the first term.  
 (b) An arithmetic progression is such that the eighth term is three times the third term. Show that the sum of the first eight terms is four times the sum of the first four terms. [J11/P13/Q6]
23. (a) The sixth term of an arithmetic progression is 23 and the sum of the first ten terms is 200. Find the seventh term.  
 (b) A geometric progression has first term 1 and common ratio  $r$ . A second geometric progression has first term 4 and common ratio  $\frac{1}{4}r$ . The two progressions have the same sum to infinity,  $S$ . Find the values of  $r$  and  $S$ . [N11/P11/Q6]
24. (a) An arithmetic progression contains 25 terms and the first term is  $-15$ . The sum of all the terms in the progression is 525. Calculate  
 (i) the common difference of the progression,  
 (ii) the last term in the progression,  
 (iii) the sum of all the positive terms in the progression.

- (b) A college agrees a sponsorship deal in which grants will be received each year for sports equipment. This grant will be \$4000 in 2012 and will increase by 5% each year. Calculate
- the value of the grant in 2022,
  - the total amount the college will receive in the years 2012 to 2022 inclusive. [N11/P12/Q10]
25. The first and second terms of a progression are 4 and 8 respectively. Find the sum of the first 10 terms given that the progression is
- an arithmetic progression,
  - a geometric progression. [N11/P13/Q2]
26. (a) The first two terms of an arithmetic progression are 1 and  $\cos^2 x$  respectively. Show that the sum of the first ten terms can be expressed in the form  $a - b \sin^2 x$ , where  $a$  and  $b$  are constants to be found.
- (b) The first two terms of a geometric progression are 1 and  $\frac{1}{3} \tan^2 \theta$  respectively, where  $0 < \theta < \frac{1}{2} \pi$ .
- Find the set of values of  $\theta$  for which the progression is convergent.
  - Find the exact value of the sum to infinity when  $\theta = \frac{1}{6} \pi$ . [J12/P11/Q7]
27. (a) In an arithmetic progression, the sum of the first  $n$  terms, denoted by  $S_n$ , is given by
- $$S_n = n^2 + 8n.$$
- Find the first term and the common difference.
- (b) In a geometric progression, the second term is 9 less than the first term. The sum of the second and third terms is 30. Given that all the terms of the progression are positive, find the first term. [J12/P12/Q7]
28. The first term of an arithmetic progression is 12 and the sum of the first 9 terms is 135.
- Find the common difference of the progression.
- The first term, the ninth term and the  $n$ th term of this arithmetic progression are the first term, the second term and the third term respectively of a geometric progression.
- Find the common ratio of the geometric progression and the value of  $n$ . [J12/P13/Q6]
29. The first term of an arithmetic progression is 61 and the second term is 57. The sum of the first  $n$  terms is  $n$ . Find the value of the positive integer  $n$ . [N12/P11/Q1]
30. (a) In a geometric progression, all the terms are positive, the second term is 24 and the fourth term is  $13\frac{1}{2}$ . Find
- the first term,
  - the sum to infinity of the progression.
- (b) A circle is divided into  $n$  sectors in such a way that the angles of the sectors are in arithmetic progression. The smallest two angles are  $3^\circ$  and  $5^\circ$ . Find the value of  $n$ . [N12/P12/Q8]

31. The first term of a geometric progression is  $5\frac{1}{3}$  and the fourth term is  $2\frac{1}{4}$ . Find
- the common ratio,
  - the sum to infinity.
- [N12/P13/Q5]
32. The third term of a geometric progression is  $-108$  and the sixth term is  $32$ . Find
- the common ratio,
  - the first term,
  - the sum to infinity.
- [J13/P11/Q4]
33. (a) The first and last terms of an arithmetic progression are  $12$  and  $48$  respectively. The sum of the first four terms is  $57$ . Find the number of terms in the progression.
- (b) The third term of a geometric progression is four times the first term. The sum of the first six terms is  $k$  times the first term. Find the possible values of  $k$ .
- [J13/P12/Q10]
34. (a) In an arithmetic progression, the sum,  $S_n$ , of the first  $n$  terms is given by  $S_n = 2n^2 + 8n$ . Find the first term and the common difference of the progression.
- (b) The first 2 terms of a geometric progression are  $64$  and  $48$  respectively. The first 3 terms of the geometric progression are also the 1st term, the 9th term and the  $n$ th term respectively of an arithmetic progression. Find the value of  $n$ .
- [J13/P13/Q9]
35. (a) In an arithmetic progression the sum of the first ten terms is  $400$  and the sum of the next ten terms is  $1000$ . Find the common difference and the first term.
- (b) A geometric progression has first term  $a$ , common ratio  $r$  and sum to infinity  $6$ . A second geometric progression has first term  $2a$ , common ratio  $r^2$  and sum to infinity  $7$ . Find the values of  $a$  and  $r$ .
- [N13/P11/Q9]
36. (a) An athlete runs the first mile of a marathon in  $5$  minutes. His speed reduces in such a way that each mile takes  $12$  seconds longer than the preceding mile.
- Given that the  $n$ th mile takes  $9$  minutes, find the value of  $n$ .
  - Assuming that the length of the marathon is  $26$  miles, find the total time, in hours and minutes, to complete the marathon.
- (b) The second and third terms of a geometric progression are  $48$  and  $32$  respectively. Find the sum to infinity of the progression.
- [N13/P12/Q7]
37. (a) In a geometric progression, the sum to infinity is equal to eight times the first term. Find the common ratio.
- (b) In an arithmetic progression, the fifth term is  $197$  and the sum of the first ten terms is  $2040$ . Find the common difference.
- [N13/P13/Q5]
38. An arithmetic progression has first term  $a$  and common difference  $d$ . It is given that the sum of the first  $200$  terms is  $4$  times the sum of the first  $100$  terms.
- Find  $d$  in terms of  $a$ .
  - Find the  $100$ th term in terms of  $a$ .
- [J14/P11/Q5]

39. The 1st, 2nd and 3rd terms of a geometric progression are the 1st, 9th and 21st terms respectively of an arithmetic progression. The 1st term of each progression is 8 and the common ratio of the geometric progression is  $r$ , where  $r \neq 1$ . Find
- the value of  $r$ ,
  - the 4th term of each progression.
- [J14/P12/Q6]
40. The first term in a progression is 36 and the second term is 32
- Given that the progression is geometric, find the sum to infinity
  - Given instead that the progression is arithmetic, find the number of terms in the progression if the sum of all the terms is 0
- [J14/P13/Q2]
41. (i) A geometric progression has first term  $a$  ( $a \neq 0$ ), common ratio  $r$  and sum to infinity  $S$ . A second geometric progression has first term  $a$ , common ratio  $2r$  and sum to infinity  $3S$ . Find the value of  $r$ .
- (ii) An arithmetic progression has first term 7. The  $n$ th term is 84 and the  $(3n)$ th term is 245. Find the value of  $n$ .
- [N14/P11/Q7]
42. (a) The sum,  $S_n$ , of the first  $n$  terms of an arithmetic progression is given by  $S_n = 32n - n^2$ . Find the first term and the common difference.
- (b) A geometric progression in which all the terms are positive has sum to infinity 20. The sum of the first two terms is 12.8. Find the first term of the progression.
- [N14/P12/Q8]
43. Three geometric progressions,  $P$ ,  $Q$  and  $R$ , are such that their sums to infinity are the first three terms respectively of an arithmetic progression.
- Progression  $P$  is  $2, 1, \frac{1}{2}, \frac{1}{4}, \dots$
- Progression  $Q$  is  $3, 1, \frac{1}{3}, \frac{1}{9}, \dots$
- Find the sum to infinity of progression  $R$ .
  - Given that the first term of  $R$  is 4, find the sum of the first three terms of  $R$ .
- [N14/P13/Q4]
44. (a) The third and fourth terms of a geometric progression are  $\frac{1}{3}$  and  $\frac{2}{9}$  respectively. Find the sum to infinity of the progression.
- (b) A circle is divided into 5 sectors in such a way that the angles of the sectors are in arithmetic progression. Given that the angle of the largest sector is 4 times the angle of the smallest sector, find the angle of the largest sector.
- [J15/P11/Q7]
45. (a) The first, second and last terms in an arithmetic progression are 56, 53 and  $-22$  respectively. Find the sum of all the terms in the progression
- (b) The first, second and third terms of a geometric progression are  $2k + 6$ ,  $2k$  and  $k + 2$  respectively, where  $k$  is a positive constant.
- Find the value of  $k$
  - Find the sum to infinity of the progression.
- [J15/P12/Q8]



46. (a) The first term of an arithmetic progression is  $-2222$  and the common difference is  $17$ . Find the value of the first positive term.
- (b) The first term of a geometric progression is  $\sqrt{3}$  and the second term is  $2\cos\theta$ , where  $0 < \theta < \pi$ . Find the set of values of  $\theta$  for which the progression is convergent. [J15/P13/Q9]
47. The first term of a progression is  $4x$  and the second term is  $x^2$ .
- (i) For the case where the progression is arithmetic with a common difference of  $12$ , find the possible values of  $x$  and the corresponding values of the third term.
- (ii) For the case where the progression is geometric with a sum to infinity of  $8$ , find the third term. [N15/P11/Q8]
48. A ball is such that when it is dropped from a height of  $1$  metre it bounces vertically from the ground to a height of  $0.96$  metres. It continues to bounce on the ground and each time the height the ball reaches is reduced. Two different models,  $A$  and  $B$ , describe this.
- Model  $A$ : The height reached is reduced by  $0.04$  metres each time the ball bounces.
- Model  $B$ : The height reached is reduced by  $4\%$  each time the ball bounces.
- (i) Find the total distance travelled vertically (up and down) by the ball from the 1st time it hits the ground until it hits the ground for the 21st time,
- (a) using model  $A$ ,
- (b) using model  $B$ .
- (ii) Show that, under model  $B$ , even if there is no limit to the number of times the ball bounces, the total vertical distance travelled after the first time it hits the ground cannot exceed  $48$  metres. [N15/P13/Q6]
49. (a) The first term of a geometric progression in which all the terms are positive is  $50$ . The third term is  $32$ . Find the sum to infinity of the progression.
- (b) The first three terms of an arithmetic progression are  $2\sin x$ ,  $3\cos x$  and  $(\sin x + 2\cos x)$  respectively, where  $x$  is an acute angle.
- (i) Show that  $\tan x = \frac{4}{3}$ .
- (ii) Find the sum of the first twenty terms of the progression. [J16/P11/Q9]
50. A water tank holds  $2000$  litres when full. A small hole in the base is gradually getting bigger so that each day a greater amount of water is lost.
- (i) On the first day after filling,  $10$  litres of water are lost and this increases by  $2$  litres each day.
- (a) How many litres will be lost on the 30th day after filling?
- (b) The tank becomes empty during the  $n$ th day after filling. Find the value of  $n$ .
- (ii) Assume instead that  $10$  litres of water are lost on the first day and that the amount of water lost increases by  $10\%$  on each succeeding day. Find what percentage of the original  $2000$  litres is left in the tank at the end of the 30th day after filling. [J16/P12/Q9]
51. The 1st, 3rd and 13th terms of an arithmetic progression are also the 1st, 2nd and 3rd terms respectively of a geometric progression. The first term of each progression is  $3$ . Find the common difference of the arithmetic progression and the common ratio of the geometric progression. [J16/P13/Q4]



52. The sum of the 1st and 2nd terms of a geometric progression is 50 and the sum of the 2nd and 3rd terms is 30. Find the sum to infinity. [N16/P11/Q5]
53. (a) A cyclist completes a long-distance charity event across Africa. The total distance is 3050 km. He starts the event on May 1st and cycles 200 km on that day. On each subsequent day he reduces the distance cycled by 5 km.
- (i) How far will he travel on May 15th?
- (ii) On what date will he finish the event?
- (b) A geometric progression is such that the third term is 8 times the sixth term, and the sum of the first six terms is  $31\frac{1}{2}$ . Find
- (i) the first term of the progression,
- (ii) the sum to infinity of the progression. [N16/P12/Q8]
54. (a) Two convergent geometric progressions,  $P$  and  $Q$ , have the same sum to infinity. The first and second terms of  $P$  are 6 and  $6r$  respectively. The first and second terms of  $Q$  are 12 and  $-12r$  respectively. Find the value of the common sum to infinity.
- (b) The first term of an arithmetic progression is  $\cos\theta$  and the second term is  $\cos\theta + \sin^2\theta$ , where  $0 \leq \theta \leq \pi$ . The sum of the first 13 terms is 52. Find the possible values of  $\theta$ . [N16/P13/Q9]

# ANSWERS

## Topic 8 - Arithmetic And Geometric Progressions

5. (i) The grant given can be represented by a GP,  
 $5000, 5000(1.05), 5000(1.05)^2, 5000(1.05)^3 + \dots$   
 $\therefore$  Grant in 2011 =  $5000(1.05)^{10} = 8144.47$   
 $\approx 8140$

(ii)  $S_{11} = \frac{\$5000[(1.05)^{11} - 1]}{1.05 - 1} = \$71034$

6. (a)  $105 + 112 + 119 + \dots + 392 + 399$   
 $399 = 105 + (n-1)(7) \Rightarrow n = 43$

$S_{43} = \frac{43}{2}(105 + 399) = 10836$

- (b) (i) 144,  $x$ , 64  
 Equating the common ratios,  $x = 96$

(ii)  $S_{\infty} = \frac{144}{1 - \frac{2}{3}} = 432$

7. (i)  $ar = 3 \Rightarrow r = \frac{3}{a}$

$12 = \frac{a}{1 - \frac{3}{a}}$

$\Rightarrow a^2 - 12a + 36 = 0 \Rightarrow a = 6$

(ii)  $S_{20} = \frac{20}{2}[2(6) + (20-1)(-3)] = -450$

8. (i)  $T_5 = a + 4d, T_{15} = a + 14d$

- (ii)  $a, a + 4d, a + 14d$  are in G.P.  
 Equating the common ratios,

$\frac{a + 4d}{a} = \frac{a + 14d}{a + 4d}$

$\Rightarrow 16d^2 - 6ad = 0 \Rightarrow 3a = 8d$

- (iii)  $3a = 8d \Rightarrow d = \frac{3}{8}a$

$r = \frac{a + 4d}{a} \Rightarrow r = \frac{a + 4(\frac{3}{8}a)}{a} = 2\frac{1}{2}$

9. (i) Given that,  $a = 81, T_4 = 24$

$T_4 = ar^{4-1} \Rightarrow 24 = 81r^3 \Rightarrow r = \frac{2}{3}$

(ii)  $S_n = \frac{81}{1 - \frac{2}{3}} = 243$

- (iii) In G.P,  $T_2 = 54, T_3 = 36$

Therefore in A.P,  $a = 54, T_4 = 36$

$36 = 54 + (4-1)d \Rightarrow d = -6$

$S_{10} = \frac{10}{2}[2(54) + (10-1)(-6)] = 270$

10. Given,  $a = 6, T_5 = 12, S_n = 90$

$12 = 6 + (5-1)d \Rightarrow d = \frac{3}{2}$

$90 = \frac{n}{2}\left(2(6) + (n-1)\frac{3}{2}\right)$

$\Rightarrow n^2 + 7n - 120 = 0$

$\Rightarrow (n+15)(n-8) = 0 \Rightarrow n = 8$

11. (a)  $S_{\infty} = \frac{0.5}{1 - (0.5)^2} = \frac{2}{3}$

- (b) Let  $T_n = 200,$

$\Rightarrow 5 + (n-1)4 = 200 \Rightarrow n = 49.75$

Last term  $> 200, \Rightarrow n = 50$

$S_{50} = \frac{50}{2}[2(5) + (50-1)4] = 5150$

12. (i) In A.P,  $T_1 = 8, T_5 = a + 4d, T_8 = a + 7d$

In G.P,  $T_2 = a + 4d \Rightarrow 8r = a + 4d \dots(1)$

$T_3 = a + 7d \Rightarrow 8r^2 = a + 7d \dots(2)$

Eliminating  $d$ , from (1) & (2), we have,

$4r^2 - 7r + 3 = 0 \Rightarrow r = \frac{3}{4}$

$\therefore 8\left(\frac{3}{4}\right) = a + 4d \Rightarrow d = -\frac{1}{2}$

(ii)  $S_{\infty} = \frac{8}{1 - \frac{3}{4}} = 32$

(iii)  $S_8 = \frac{8}{2}\left[2(8) + (8-1)\left(-\frac{1}{2}\right)\right] = 50$

13. (i)  $a + d = 96 \dots\dots\dots(i)$

$a + 3d = 54 \dots\dots\dots(ii)$

solving (i) & (ii) simultaneously,  $a = 117$

(ii)  $ar = 96 \dots\dots(i)$   
 $ar^3 = 54 \dots\dots(ii)$   
 Dividing (ii) by (i) gives,  $r = \frac{3}{4}$   
 Put  $r$  into (i),  $\Rightarrow a = 128$

14. (i)  $22 = a + 8d$   
 $49 = 4a + 6d$   
 solving simultaneously gives,  
 $a = 10, d = 1.5$

(ii)  $46 = 10 + (n-1)(1.5) \Rightarrow n = 25$

15. (a)  $100 + 105 + 110 + 115 \dots\dots + 300$   
 $300 = 100 + (n-1)5 \Rightarrow n = 41$   
 $S_{41} = \frac{41}{2}(100 + 300) = 8200$

(b) (i)  $35 = \frac{a(1 - (-\frac{2}{3})^3)}{1 - (-\frac{2}{3})} \Rightarrow a = 45$

(ii)  $S_{\infty} = \frac{45}{1 - (-\frac{2}{3})} = 27$

16. (i)  $r = -\frac{1}{2}, T_{10} = 12\left(-\frac{1}{2}\right)^9 = -\frac{3}{128}$

(ii)  $S_{\infty} = \frac{12}{1 - (-\frac{1}{2})} = 8$

17. (a)  $T_5 = 18, \Rightarrow 18 = a + 4d$   
 $S_5 = 75, \Rightarrow 75 = \frac{5}{2}[2a + 4d]$   
 Solving simultaneously gives,  $a = 12, d = \frac{3}{2}$

(b)  $T_4 = \frac{27}{4}, \Rightarrow 16r^3 = \frac{27}{4} \Rightarrow r = \frac{3}{4}$   
 $S_{\infty} = \frac{16}{1 - \frac{3}{4}} = 64$

18. (a)  $161, 154, \dots, \therefore d = -7$   
 $S_m = 0$   
 $\Rightarrow \frac{m}{2}[2(161) + (m-1)(-7)] = 0 \Rightarrow m = 47$

(b)  $S_n < 90\%(S_{\infty})$   
 $\Rightarrow \frac{a(1-r^n)}{(1-r)} < \frac{90}{100}\left(\frac{a}{1-r}\right)$   
 $\Rightarrow 1-r^n < 0.9 \Rightarrow r^n > 0.1$

19. (a)  $2000 = \frac{100}{1-r} \Rightarrow r = \frac{19}{20}$   
 $T_2 = 100\left(\frac{19}{20}\right) = 95$

(b) (i)  $T_3 = 90, \Rightarrow 90 = a + 2d$   
 $T_5 = 80, \Rightarrow 80 = a + 4d$   
 solving simultaneously gives,  
 $a = 100, d = -5$

(ii)  $S_m = S_{m+1}$   
 $\Rightarrow \frac{m}{2}[2(100) + (m-1)(-5)]$   
 $= \frac{m+1}{2}[2(100) + (m)(-5)]$   
 $\Rightarrow m = 20$

(iii)  $S_n = 0, \Rightarrow \frac{n}{2}[2(100) + (n-1)(-5)] = 0$   
 $\Rightarrow n = 41$

20. (i) Prize money: 1000, 2000, 3000.....40000  
 Donation:  $50 + 100 + 150 + \dots + 2000$   
 Total donation,  $S_{40} = \frac{40}{2}[2(50) + (40-1)50]$   
 $= \$41000$

(ii) 1000,  $1000(1.1), 1000(1.1)^2, 1000(1.1)^3 + \dots$   
 Donation:  $50 + 50(1.1) + 50(1.1)^2 + \dots$   
 Total donation,  $S_{40} = \frac{50(1.1^{40} - 1)}{1.1 - 1}$   
 $= \$22,130 \approx \$22,100$

21. (a) Let the angles be,  $a, a+d, a+2d, \dots, a+5d$   
 Given,  $a+5d = 4a \Rightarrow 5d = 3a \dots\dots(1)$   
 also,  $S_6 = 2\pi \Rightarrow 2a+5d = \frac{2\pi}{3} \dots\dots(2)$   
 Subst. (1) into (2) gives,  $a = \frac{2\pi}{15}$   
 Perimeter =  $5 + 5 + 5\left(\frac{2\pi}{15}\right) = 12.1$  cm

(b) (i)  $2k+3, k+6, k$  are in G.P,  
 $\therefore \frac{k+6}{2k+3} = \frac{k}{k+6}$   
 $\Rightarrow k^2 - 9k - 36 = 0 \Rightarrow k = 12$   
 (ii) For  $k = 12$ , the G.P is: 27, 18, 12  
 $S_{\infty} = \frac{27}{1 - \frac{2}{3}} = 81$

22. (a)  $S_{\infty} = 3a \Rightarrow \frac{a}{1-r} = 3a \Rightarrow r = \frac{2}{3}$   
 $a^2 = 20 \dots\dots (2) \Rightarrow a = 45$

(b)  $T_8 = 3T_3$   
 $\Rightarrow a + 7d = 3(a + 2d) \Rightarrow 2a = d$   
 $S_8 = \frac{8}{2}[2a + (8-1)d] = 4[d + 7d] = 32d$   
 $S_4 = \frac{4}{2}[2a + (4-1)d] = 2[d + 3d] = 8d$   
 $\Rightarrow S_8 = 4S_4$

23. (a)  $T_6 = 23 \Rightarrow a + 5d = 23$   
 $S_{10} = 200 \Rightarrow 2a + 9d = 40$   
 solving simultaneously gives,  $a = -7, d = 6$   
 $\therefore T_7 = 29$

(b)  $\frac{1}{1-r} = \frac{4}{1-\frac{1}{4}r} \Rightarrow 15r = 12 \Rightarrow r = \frac{4}{5}$   
 Sum to infinity,  $S = 5$

24. (a) (i) We have,  $n = 25, a = -15, S_{25} = 525$   
 $525 = \frac{25}{2}[2(-15) + (25-1)d] \Rightarrow d = 3$

(ii) Last term,  $T_{25} = -15 + (25-1)(3) = 57$

(iii)  $-15, -12, -9, -6, -3, 0, 3, 6, \dots, 57$   
 $\therefore$  Number of positive terms = 20  
 $S_{20} = \frac{20}{2}[2(0) + 19(3)] = 570$

(b) (i) The grant from 2012 to 2022 is,  
 $\$4000, \$4000(1.05), \$4000(1.05)^2, \dots$   
 $\therefore$  Grant in 2022 is,  $T_{11} = \$4000(1.05)^{10}$   
 $= \$6516$

(ii)  $S_{11} = \frac{4000((1.05)^{11} - 1)}{1.05 - 1} = \$56827.2$   
 $\approx \$56800$

25. (i)  $4, 8, \dots, d = 4$   
 $S_{10} = \frac{10}{2}[2(4) + 9(4)] = 220$

(ii)  $4, 8, \dots, r = 2$   
 $S_{10} = \frac{4(1-2^{10})}{1-2} = 4092$

26. (a)  $a = 1, d = \cos^2 x - 1$   
 $S_{10} = \frac{10}{2}[2(1) + 9(\cos^2 x - 1)]$   
 $= 5[2 - 9\sin^2 x] = 10 - 45\sin^2 x$

(b) (i)  $\frac{1}{3}\tan^2 \theta < 1$   
 $\Rightarrow -\sqrt{3} < \tan \theta < \sqrt{3}$   
 $\therefore$  within the given range,  $0 < \theta < \frac{\pi}{3}$

(ii)  $S_r = \frac{1}{1 - \frac{1}{3}\tan^2 \frac{\pi}{6}} = \frac{1}{1 - \frac{1}{3}\left(\frac{1}{\sqrt{3}}\right)^2} = \frac{9}{8}$

27. (a)  $S_1 = (1)^2 + 8(1) = 9, S_2 = (2)^2 + 8(2) = 20$   
 $\therefore$  First term = 9  
 Second term =  $S_2 - S_1 = 11$   
 Common difference,  $d = 11 - 9 = 2$

(b) Given,  $T_2 = T_1 - 9 \Rightarrow ar = a - 9 \dots\dots(1)$   
 $T_2 + T_3 = 30 \Rightarrow ar + ar^2 = 30 \dots\dots(2)$   
 dividing (2) by (1),  $\frac{ar(1+r)}{a(1-r)} = \frac{30}{9}$   
 $\Rightarrow 3r^2 + 13r - 10 = 0 \Rightarrow r = \frac{2}{3}$   
 Subst.  $r$  in (1) gives,  $a = 27$

28. (i) We have,  $a = 12, S_9 = 135$   
 $\Rightarrow 135 = \frac{9}{2}[2(12) + 8d] \Rightarrow d = \frac{3}{4}$

(ii) In A.P,  $T_1 = 12, T_9 = 18, T_n = \frac{45+3n}{4}$   
 In G.P,  $12, 18, \frac{45+3n}{4}$   
 $\therefore$  Common ratio =  $\frac{3}{2}$   
 also,  $\frac{45+3n}{4} = \frac{3}{2} \Rightarrow n = 21$

29.  $n = \frac{n}{2}[2(61) + (n-1)(-4)] \Rightarrow n = 31$

30. (a) (i)  $ar = 24 \dots\dots(1), ar^3 = \frac{27}{2} \dots\dots(2)$   
 $\frac{ar^3}{ar} = \frac{\frac{27}{2}}{24} \Rightarrow r = \frac{3}{4}$   
 Subst.  $r$  into (1) gives,  $a = 32$

(ii)  $S_n = \frac{32}{1 - \frac{3}{4}} = 128$

(b) Given,  $a = 3^\circ, d = 2^\circ, S_n = 360^\circ$   
 $360 = \frac{n}{2}[2(3) + (n-1)(2)]$   
 $\Rightarrow n^2 + 2n - 360 = 0$   
 $\Rightarrow (n+20)(n-18) = 0 \Rightarrow n = 18$

31. (i) Given,  $a = \frac{16}{3}$ ,  $ar^3 = \frac{9}{4}$   
 $\frac{ar^3}{a} = \frac{\frac{9}{4}}{\frac{16}{3}} \Rightarrow r^3 = \frac{27}{64} \Rightarrow r = \frac{3}{4}$

(ii)  $S_n = \frac{\frac{16}{3}}{1 - \frac{3}{4}} = 21\frac{1}{3}$

32. (i) Given,  $ar^2 = -108$ ,  $ar^5 = 32$   
 $\frac{ar^5}{ar^2} = \frac{32}{-108} \Rightarrow r^3 = -\frac{8}{27} \Rightarrow r = -\frac{2}{3}$

(ii)  $a\left(-\frac{2}{3}\right)^2 = -108 \Rightarrow a = -243$

(iii)  $S_n = \frac{-243}{1 - \left(-\frac{2}{3}\right)} = -145.8$

33. (a)  $S_4 = 57$ ,  
 $\Rightarrow 57 = \frac{4}{2}[2(12) + (4-1)d] \Rightarrow d = \frac{3}{2}$   
 $T_n = 48$ ,  
 $\Rightarrow 48 = 12 + (n-1)\frac{3}{2} \Rightarrow n = 25$

(b)  $T_3 = 4a \Rightarrow ar^2 = 4a \Rightarrow r = \pm 2$   
 $S_6 = ka \Rightarrow \frac{a(r^6 - 1)}{r - 1} = ka \Rightarrow k = \frac{r^6 - 1}{r - 1}$   
 when  $r = 2$ ,  $k = \frac{(2)^6 - 1}{2 - 1} \Rightarrow k = 63$   
 when  $r = -2$ ,  $k = \frac{(-2)^6 - 1}{-2 - 1} \Rightarrow k = -21$

34. (a)  $S_1 = 10$ ,  $S_2 = 24$ , therefore  $T_1 = 10$ ,  $T_2 = 14$   
 $\therefore a = 10$ ,  $d = 4$

(b) First 3 terms of G.P are: 64, 48, 36  
 Therefore in A.P,  $T_1 = 64 \Rightarrow a = 64$   
 $T_2 = 48 \Rightarrow 64 + 8d = 48 \Rightarrow d = -2$   
 $T_n = 36 \Rightarrow 64 + (n-1)(-2) = 36$   
 $\Rightarrow n = 15$

35. (a)  $S_{10} = 400 \Rightarrow 400 = \frac{10}{2}[2a + 9d]$   
 $\Rightarrow 2a + 9d = 80 \dots\dots(1)$

$S_{20} = 1400 \Rightarrow 1400 = \frac{20}{2}[2a + 19d]$   
 $\Rightarrow 2a + 19d = 140 \dots\dots(2)$

Solving simultaneously gives,  $a = 13$ ,  $d = 6$

(b)  $\frac{a}{1-r} = 6 \Rightarrow a + 6r = 6 \dots\dots(1)$

$\frac{2a}{1-r^2} = 7 \Rightarrow 2a + 7r^2 = 7 \dots\dots(2)$

Eliminating  $a$  from (1) & (2), we have,

$7r^2 - 12r + 5 = 0 \Rightarrow r = \frac{5}{7}$

Subst.  $r$  into (1) gives,  $a = \frac{12}{7}$

36. (a) (i) The time, in seconds, can be represented by an AP. 300, 312, 324,  $\dots\dots$ , 540

$540 = 300 + (n-1)(12) \Rightarrow n = 21$

(ii) Consider the AP, 300 + 312 + 324 +  $\dots\dots$

$S_{26} = \frac{26}{2}[2(300) + (26-1)(12)]$

$= 11700$  seconds = 3 hours 15 min.

(b)  $ar = 48$ ,  $ar^2 = 32$   
 $\Rightarrow \frac{ar^2}{ar} = \frac{32}{48} \Rightarrow r = \frac{2}{3}$   
 $\therefore a\left(\frac{2}{3}\right) = 48 \Rightarrow a = 72$

Sum to infinity = 216

37. (a)  $\frac{a}{1-r} = 8a \Rightarrow r = \frac{7}{8}$

(b)  $T_5 = 197 \Rightarrow a + 4d = 197 \dots\dots(1)$

$S_{10} = 2040 \Rightarrow 2a + 9d = 408 \dots\dots(2)$

Solving simultaneously gives,  $d = 14$

38. (i)  $S_{200} = 4S_{100}$   
 $\Rightarrow \frac{200}{2}[2a + 199d] = 4 \times \frac{100}{2}[2a + 99d]$   
 $\Rightarrow 2a + 199d = 4a + 198d \Rightarrow d = 2a$

(ii)  $T_{100} = a + 99d$   
 $= a + 99(2a) = 199a$

39. (i) First 3 terms of the GP are: 8,  $8r$ ,  $8r^2$

$\therefore$  In AP,  $a = 8$ ,

$T_9 = 8r \Rightarrow 8 + 8d = 8r \Rightarrow d = r - 1$

$T_{21} = 8r^2 \Rightarrow 8 + 20d = 8r^2$

$\Rightarrow 8 + 20(r - 1) = 8r^2 \Rightarrow r = \frac{3}{2}$

(ii) In G.P,  $T_4 = 8\left(\frac{3}{2}\right)^3 = 27$

In AP,  $T_4 = 8 + 3d$



40. (i) Sum to infinity =  $\frac{36}{1 - \frac{8}{9}} = 324$

(ii)  $S_n = 0$   
 $\Rightarrow \frac{n}{2}[2(36) + (n-1)(-4)] = 0$   
 $\Rightarrow 38n - 2n^2 = 0 \Rightarrow n = 19$

41. (i)  $S = \frac{a}{1-r}$   
 $3S = \frac{a}{1-2r} \Rightarrow S = \frac{a}{3-6r}$   
 $\therefore \frac{a}{1-r} = \frac{a}{3-6r} \Rightarrow r = \frac{2}{5}$

(ii)  $T_n = 84 \Rightarrow 7 + (n-1)d = 84 \dots\dots\dots(1)$   
 $T_{3n} = 245 \Rightarrow 7 + (3n-1)d = 245 \dots\dots\dots(2)$   
 Solving (1) & (2) simultaneously gives,  
 $n = 23, d = \frac{7}{2}$

42. (a)  $S_1 = 31, S_2 = 60$   
 first term = 31, second term =  $60 - 31 = 29$   
 common difference = -2

(b) Given,  $\frac{a}{1-r} = 20 \Rightarrow a = 20(1-r)$   
 Also,  $a + ar = 12.8 \Rightarrow a(1+r) = 12.8$   
 Eliminating  $a$  gives,  $r = 0.6$   
 $\therefore a = 20(1 - 0.6) = 8$

43. (i)  $S_x$  of  $P = \frac{2}{1 - \frac{1}{2}} = 4, S_x$  of  $Q = \frac{3}{1 - \frac{1}{3}} = 4.5$   
 $\therefore$  first two terms of AP are, 4, 4.5  
 Thus,  $S_x$  of  $R = 5$

(ii)  $S_x$  of  $R = 5 \Rightarrow \frac{4}{1-r} = 5 \Rightarrow r = \frac{1}{5}$   
 $\therefore$  Sum of first 3 terms =  $4 + 4\left(\frac{1}{5}\right) + 4\left(\frac{1}{5}\right)^2$   
 $= \frac{124}{25}$

44. (a)  $ar^2 = \frac{1}{3}, ar^3 = \frac{2}{9}$   
 $\Rightarrow \frac{ar^3}{ar^2} = \frac{\frac{2}{9}}{\frac{1}{3}} \Rightarrow r = \frac{2}{3}$   
 $\therefore a\left(\frac{2}{3}\right)^2 = \frac{1}{3} \Rightarrow a = \frac{3}{4}$   
 Sum to infinity =  $\frac{\frac{3}{4}}{1 - \frac{2}{3}} = \frac{9}{4}$

(b) Let angles be,  $a, a+d, a+2d, a+3d, a+4d$   
 Given,  $a+4d = 4a \Rightarrow 4d = 3a \dots\dots(1)$

also,  $S_5 = 2\pi \Rightarrow 2a + 4d = \frac{4\pi}{5} \dots\dots(2)$

Subst. (1) into (2) gives,  $a = \frac{4\pi}{25}$

$\therefore 4d = 3\left(\frac{4\pi}{25}\right) \Rightarrow d = \frac{3\pi}{25}$

Angle of the largest sector =  $\frac{16}{25}\pi$

45. (a) We have,  $a = 56, d = -3, T_n = -22$ ,  
 using,  $T_n = a + (n-1)d$  gives  $n = 27$

$S_{27} = \frac{27}{2}[56 - 22] = 459$

(b) (i) Equating the common ratios,

$\frac{2k}{2k+6} = \frac{k+2}{2k}$   
 $\Rightarrow k^2 - 5k - 6 = 0 \Rightarrow k = 6$

(ii) For  $k = 6$ , the 3 terms are, 18, 12, 8

Sum to infinity =  $\frac{18}{1 - \frac{2}{3}} = 54$

46. (a) For +ve terms,  $T_n > 0$   
 $\Rightarrow -2222 + (n-1)(17) > 0 \Rightarrow n > 131.7$

$\therefore$  First positive term is at  $n = 132$

$T_{132} = -2222 + (132-1)(17) = 5$

(b)  $|r| < 1$

$\Rightarrow -1 < \frac{2\cos\theta}{\sqrt{3}} < 1 \Rightarrow \frac{\pi}{6} < \theta < \frac{5\pi}{6}$

47. (i)  $d = x^2 - 4x \Rightarrow x^2 - 4x - 12 = 0$   
 $\Rightarrow (x-6)(x+2) = 0 \Rightarrow x = -2, \text{ or } 6$

when  $x = -2, T_3 = 16$

when  $x = 6, T_3 = 48$

(ii)  $8 = \frac{4x}{1 - \frac{x}{4}} \Rightarrow x = \frac{4}{3}$

$T_3 = ar^2 = \frac{16}{3}\left(\frac{1}{3}\right)^2 = \frac{16}{27}$

48. (i) (a)  $a = 0.96, d = -0.04, n = 20$

$S_{20} = \frac{20}{2}[2(0.96) + 19(-0.04)] = 11.6$

Total distance =  $2 \times 11.6 = 23.2$  metres

(b)  $a = 0.96, r = 0.96, n = 20$

$S_{20} = \frac{0.96(1 - 0.96^{20})}{1 - 0.96} = 13.39$

Total distance =  $2 \times 13.39 = 26.8$  metres

Ask Nadeem  
Q46 both parts

(ii) Sum to infinity =  $\frac{2(0.96)}{1-0.96} = 48$  m.  
 $\therefore$  Total dist. covered cannot exceed 48 m.

49. (a)  $a = 50, ar^2 = 32, \Rightarrow r = \frac{4}{5}$

$$S_{\infty} = \frac{50}{1-\frac{4}{5}} = 250$$

(b) (i) Equating the common differences,  
 $3 \cos x - 2 \sin x = (\sin x + 2 \cos x) - 3 \cos x$   
 $\Rightarrow 3 \sin x = 4 \cos x \Rightarrow \tan x = \frac{4}{3}$

(ii)  $\tan x = \frac{4}{3}, \Rightarrow \sin x = \frac{4}{5}, \cos x = \frac{3}{5}$

$$\therefore a = \frac{8}{5}, d = \frac{1}{5}$$

$$S_{20} = \frac{20}{2} \left[ 2\left(\frac{8}{5}\right) + 19\left(\frac{1}{5}\right) \right] = 70$$

50. (i) (a) Loss of water forms an AP,  
 10, 12, 14, .....  
 $\therefore T_{30} = 10 + (30-1)(2) = 68$  litres

(b) We have,  $a = 10, d = 2, S_n = 2000$   
 $2000 = \frac{n}{2} [2(10) + (n-1)(2)]$   
 $\Rightarrow n^2 + 9n - 2000 = 0 \Rightarrow n = 40.45$   
 $\therefore$  the tank gets empty during 41th day.

(ii) Loss of water forms a GP,  
 $10 + 10(1.1) + 10(1.1)^2 + \dots + 10(1.1)^{29}$   
 Water lost in 30 days,  $S_{30} = 1644.94$  litres  
 $\therefore$  Percentage of water left in the tank  
 $= \frac{2000 - 1644.94}{2000} \times 100 = 17.8\%$

51. First 3 terms of the GP are:  $3, 3r, 3r^2$   
 $\therefore$  In AP,  $T_3 = 3 + 2d \Rightarrow 3 + 2d = 3r$   
 $T_{13} = 3 + 12d \Rightarrow 3 + 12d = 3r^2$   
 solving simultaneously gives,  
 $r^2 - 6r + 5 = 0 \Rightarrow r = 5$   
 $\therefore 3 + 2d = 3(5) \Rightarrow d = 6$

52.  $a + ar = 50 \Rightarrow (1+r) = \frac{50}{a}$  .....(1),  
 $ar + ar^2 = 30 \Rightarrow ar(1+r) = 30$  .....(2)  
 solving simultaneously gives,  $r = \frac{3}{5}, a = \frac{125}{4}$   
 Sum to infinity =  $\frac{\frac{125}{4}}{1-\frac{3}{5}} = \frac{625}{8}$

53. (a) (i) The distance cycled forms an AP.  
 200, 195, 190, .....  
 Distance travelled on 15th May is,  
 $T_{15} = 200 + 14(-5) = 130$  km

(ii)  $S_n = 3050$  km  
 $\Rightarrow 3050 = \frac{n}{2} [2(200) + (n-1)(-5)]$   
 $\Rightarrow n^2 - 81n + 1220 = 0 \Rightarrow n = 20$   
 $\therefore$  He will finish the event on 20th May

(b) (i) Given that,  $ar^2 = 8ar^5 \Rightarrow r = \frac{1}{2}$   
 also given,  $S_6 = 31\frac{1}{2}, n = 6$   
 using,  $S_n = \frac{a(1-r^n)}{1-r}$  gives,  $a = 16$

(ii)  $S_{\infty} = 32$

54. (a)  $S_x$  of  $P = S_x$  of  $Q$   
 $\Rightarrow \frac{6}{1-r} = \frac{12}{1+r} \Rightarrow r = \frac{1}{3}$   
 $\therefore$  Sum to infinity =  $\frac{6}{1-\frac{1}{3}} = 9$

(b)  $S_{13} = 52$   
 $\Rightarrow \frac{13}{2} [2(\cos \theta) + 12(\sin^2 \theta)] = 52$   
 $\Rightarrow 12 \cos^2 \theta - 2 \cos \theta - 4 = 0$   
 $\Rightarrow \cos \theta = -\frac{1}{2}$  or  $\cos \theta = \frac{2}{3}$   
 $\therefore \theta = 0.841, 2.09$ , radians

30/8/17

R-No

work

Handwriting

# TOPIC 9 Differentiation

5. A curve has equation  $y = \frac{k}{x}$ . Given that the gradient of the curve is  $-3$  when  $x = 2$ , find the value of the constant  $k$ .  
[J06/P12/Q1]

6. The diagram shows the curve,  $y = x^3 - 3x^2 - 9x + k$ , where  $k$  is constant. The curve has a minimum point on the  $x$ -axis.

- (i) Find the value of  $k$
- (ii) Find the coordinates of the maximum point of the curve.
- (iii) State the set of values of  $x$  for which  $x^3 - 3x^2 - 9x + k$  is a decreasing function of  $x$ .
- (iv) Find the area of the shaded region.

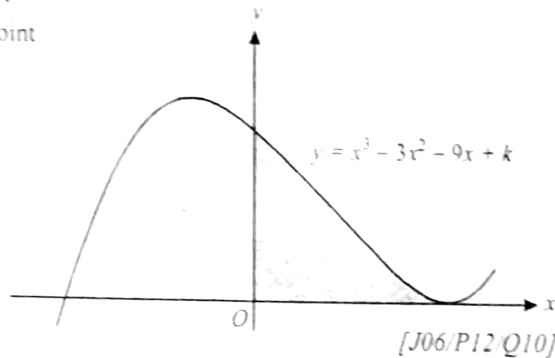

7. The equation of a curve is  $y = \frac{6}{5-2x}$ .

- (i) Calculate the gradient of the curve at the point where  $x = 1$ .
- (ii) A point with coordinates  $(x, y)$  moves along the curve in such a way that the rate of increase of  $y$  has a constant value of  $0.02$  units per second. Find the rate of increase of  $x$  when  $x = 1$ .
- (iii) The region between the curve, the  $x$ -axis and the lines  $x = 0$  and  $x = 1$  is rotated through  $360^\circ$  about the  $x$ -axis. Show that the volume obtained is  $\frac{12}{5}\pi$ .  
[N06/P12/Q8]

8. The diagram shows an open container constructed out of  $200 \text{ cm}^2$  of cardboard. The two vertical end pieces are isosceles triangles with sides  $5x \text{ cm}$ ,  $5x \text{ cm}$  and  $8x \text{ cm}$ , and the two side pieces are rectangles of length  $y \text{ cm}$  and width  $5x \text{ cm}$ , as shown. The open top is a horizontal rectangle.

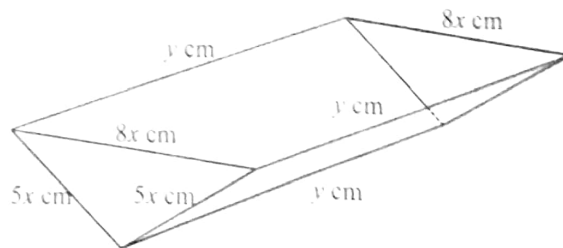

- (i) Show that  $y = \frac{200 - 24x^2}{10x}$ .
- (ii) Show that the volume,  $V \text{ cm}^3$ , of the container is given by  $V = 240x - 28.8x^3$ .  
Given that  $x$  can vary,
- (iii) find the value of  $x$  for which  $V$  has a stationary value,
- (iv) determine whether it is a maximum or a minimum stationary value.  
[N06/P12/Q9]

AL Mathematics (P1)

9. The equation of a curve is  $y = 2x + \frac{8}{x^2}$
- Obtain expressions for  $\frac{dy}{dx}$  and  $\frac{d^2y}{dx^2}$
  - Find the coordinates of the stationary point on the curve and determine the nature of the stationary point
  - Show that the normal to the curve at the point  $(2, 2)$  intersects the  $x$ -axis at the point  $(10, 0)$
  - Find the area of the region enclosed by the curve, the  $x$ -axis and the lines  $x = 1$  and  $x = 2$
- [J07/P12/Q10]

10. The equation of a curve is  $y = (2x - 3)^3 - 6x$ .
- Express  $\frac{dy}{dx}$  and  $\frac{d^2y}{dx^2}$  in terms of  $x$
  - Find the  $x$ -coordinates of the two stationary points and determine the nature of each stationary point
- [N07/P12/Q8]

11.

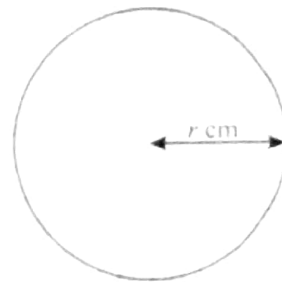

A wire, 80cm long, is cut into two pieces. One piece is bent to form a square of side  $x$  cm and the other piece is bent to form a circle of radius  $r$  cm (see diagram). The total area of the square and the circle is  $A$  cm<sup>2</sup>.

- Show that  $A = \frac{(\pi + 4)x^2 - 160x + 1600}{\pi}$
  - Given that  $x$  and  $r$  can vary, find the value of  $x$  for which  $A$  has a stationary value.
- [N08/P12/Q7]

12. The diagram shows the curve  $y = x^3 - 6x^2 + 9x$  for  $x \geq 0$ . The curve has a maximum point at  $A$  and a minimum point on the  $x$ -axis at  $B$ . The normal to the curve at  $C(2, 2)$  meets the normal to the curve at  $B$  at the point  $D$ .

- Find the coordinates of  $A$  and  $B$
- Find the equation of the normal to the curve at  $C$ .
- Find the area of the shaded region.

[J09/P12/Q11]

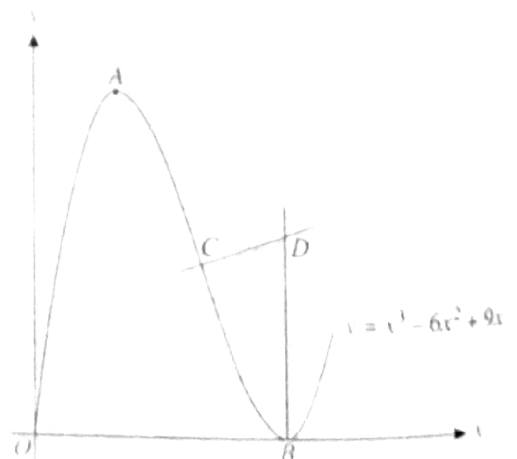

13. The equation of a curve is  $y = \frac{12}{x^2 + 3}$ .

(i) Obtain an expression for  $\frac{dy}{dx}$ .

(ii) Find the equation of the normal to the curve at the point  $P(1, 3)$ .

(iii) A point is moving along the curve in such a way that the  $x$ -coordinate is increasing at a constant rate of 0.012 units per second. Find the rate of change of the  $y$ -coordinate as the point passes through  $P$ .

[N09/P11/Q7]

14. A piece of wire of length 50 cm is bent to form the perimeter of a sector  $POQ$  of a circle. The radius of the circle is  $r$  cm and the angle  $POQ$  is  $\theta$  radians (see diagram).

(i) Express  $\theta$  in terms of  $r$  and show that the area,  $A \text{ cm}^2$ , of the sector is given by  $A = 25r - r^2$ .

(ii) Given that  $r$  can vary, find the stationary value of  $A$  and determine its nature.

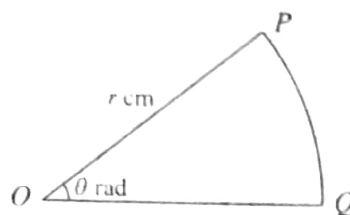

[N09/P12/Q7]

15. The diagram shows part of the curve

$$y = 2 - \frac{18}{2x + 3},$$

which crosses the  $x$ -axis at  $A$

and the  $y$ -axis at  $B$ . The normal to the curve at  $A$  crosses the  $y$ -axis at  $C$ .

(i) Show that the equation of the line  $AC$  is  $9x + 4y = 27$ .

(ii) Find the length of  $BC$ .

[J10/P11/Q7]

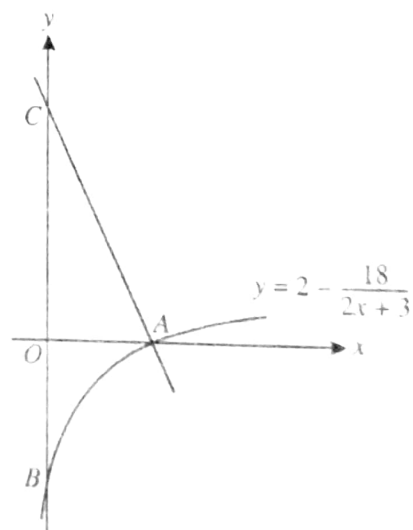

16. A solid rectangular block has a square base of side  $x$  cm. The height of the block is  $h$  cm and the total surface area of the block is  $96 \text{ cm}^2$ .

(i) Express  $h$  in terms of  $x$  and show that the volume,  $V \text{ cm}^3$ , of the block is given by

$$V = 24x - \frac{1}{2}x^3.$$

Given that  $x$  can vary,

(ii) find the stationary value of  $V$ ,

(iii) determine whether this stationary value is a maximum or a minimum.

[J10/P12/Q8]



17. The equation of a curve is  $y = \frac{1}{6}(2x-3)^3 - 4x$
- Find  $\frac{dy}{dx}$ .
  - Find the equation of the tangent to the curve at the point where the curve intersects the  $y$ -axis.
  - Find the set of values of  $x$  for which  $\frac{1}{6}(2x-3)^3 - 4x$  is an increasing function of  $x$ .
- [J10/P12/Q10]

18. The equation of a curve is  $y = 3 + 4x - x^2$ .
- Show that the equation of the normal to the curve at the point  $(3, 6)$  is  $2y = x + 9$ .
  - Given that the normal meets the coordinate axes at points  $A$  and  $B$ , find the coordinates of the mid-point of  $AB$ .
  - Find the coordinates of the point at which the normal meets the curve again.
- [N10/P11/Q10]

19. The diagram shows a metal plate consisting of a rectangle with sides  $x$  cm and  $y$  cm and a quarter-circle of radius  $x$  cm. The perimeter of the plate is 60 cm.

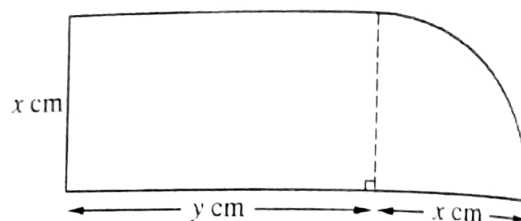

- Express  $y$  in terms of  $x$ .
- Show that the area of the plate,  $A$  cm<sup>2</sup>, is given by  $A = 30x - x^2$ .

Given that  $x$  can vary,

- find the value of  $x$  at which  $A$  is stationary,
- find this stationary value of  $A$ , and determine whether it is a maximum or a minimum value.

[N10/P11/Q8]

20. The length,  $x$  metres, of a Green Anaconda snake which is  $t$  years old is given approximately by the formula

$$x = 0.7\sqrt{(2t-1)},$$

where  $1 \leq t \leq 10$ . Using this formula, find

- $\frac{dx}{dt}$ ,
- the rate of growth of a Green Anaconda snake which is 5 years old.

[N10/P12/Q3]

21. The diagram shows an open rectangular tank of height  $h$  metres covered with a lid. The base of the tank has sides of length  $x$  metres and  $\frac{1}{2}x$  metres and the lid is a rectangle with sides of length  $\frac{5}{4}x$  metres and  $\frac{4}{5}x$  metres. When full the tank holds 4 m<sup>3</sup> of water. The material from which the tank is made is of negligible thickness. The external surface area of the tank together with the area of the top of the lid is  $A$  m<sup>2</sup>.

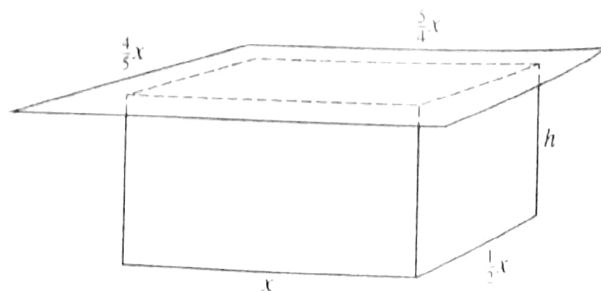

- (i) Express  $h$  in terms of  $x$  and hence show that  $A = \frac{3}{2}x^2 + \frac{24}{x}$
- (ii) Given that  $x$  can vary, find the value of  $x$  for which  $A$  is a minimum, showing clearly that  $A$  is a minimum and not a maximum. [N10/P12/Q10]

22. A curve has equation  $y = \frac{1}{x-3} + x$ .

- (i) Find  $\frac{dy}{dx}$  and  $\frac{d^2y}{dx^2}$
- (ii) Find the coordinates of the maximum point  $A$  and the minimum point  $B$  on the curve. [N10/P13/Q5]

23. The volume of a spherical balloon is increasing at a constant rate of  $50 \text{ cm}^3$  per second. Find the rate of increase of the radius when the radius is  $10 \text{ cm}$ . [Volume of a sphere =  $\frac{4}{3}\pi r^3$ .] [J11/P11/Q2]

24. The variables  $x$ ,  $y$  and  $z$  can take only positive values and are such that

$$z = 3x + 2y \quad \text{and} \quad xy = 600.$$

- (i) Show that  $z = 3x + \frac{1200}{x}$ .
- (ii) Find the stationary value of  $z$  and determine its nature. [J11/P11/Q6]

25. A curve has equation  $y = \frac{4}{3x-4}$  and  $P(2, 2)$  is a point on the curve.

- (i) Find the equation of the tangent to the curve at  $P$ . [4]
- (ii) Find the angle that this tangent makes with the  $x$ -axis. [2]
- [J11/P12/Q4]

26. A curve has equation  $y = 3x^3 - 6x^2 + 4x + 2$ . Show that the gradient of the curve is never negative. [N11/P11/Q2]

27. The diagram shows the dimensions in metres of an L-shaped garden. The perimeter of the garden is  $48 \text{ m}$ .

- (i) Find an expression for  $y$  in terms of  $x$ .
- (ii) Given that the area of the garden is  $A \text{ m}^2$ , show that  $A = 48x - 8x^2$ .
- (iii) Given that  $x$  can vary, find the maximum area of the garden, showing that this is a maximum value rather than a minimum value.

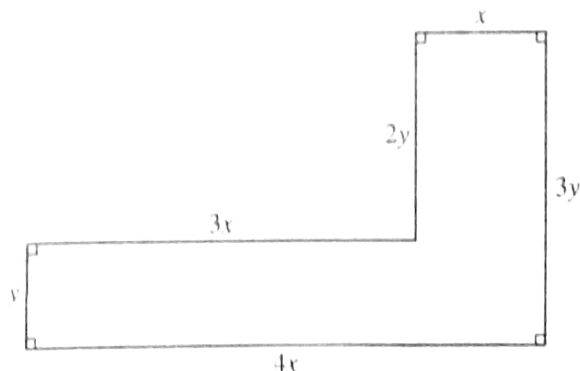

[N11/P11/Q7]

## AL Mathematics (P1)

28. A curve is such that  $\frac{dy}{dx} = 5 - \frac{8}{x^2}$ . The line  $3y + x = 17$  is the normal to the curve at the point  $P$  on the curve. Given that the  $x$ -coordinate of  $P$  is positive, find
- the coordinates of  $P$ , [M11/P12/Q7]
  - the equation of the curve.
29. A curve  $y = f(x)$  has a stationary point at  $P(3, -10)$ . It is given that  $f'(x) = 2x^2 + kx - 12$ , where  $k$  is a constant.
- Show that  $k = -2$  and hence find the  $x$ -coordinate of the other stationary point,  $Q$ .
  - Find  $f''(x)$  and determine the nature of each of the stationary points  $P$  and  $Q$ . [M11/P13/Q8]
  - Find  $f(x)$ .
30. A watermelon is assumed to be spherical in shape while it is growing. Its mass,  $M$  kg, and radius,  $r$  cm, are related by the formula  $M = kr^3$ , where  $k$  is a constant. It is also assumed that the radius is increasing at a constant rate of 0.1 centimetres per day. On a particular day the radius is 10 cm and the mass is 3.2 kg. Find the value of  $k$  and the rate at which the mass is increasing on this day. [J12/P11/Q4]
31. It is given that a curve has equation  $y = f(x)$ , where  $f(x) = x^3 - 2x^2 + x$ .
- Find the set of values of  $x$  for which the gradient of the curve is less than 5.
  - Find the values of  $f(x)$  at the two stationary points on the curve and determine the nature of each stationary point. [J12/P11/Q10]
32. The equation of a curve is  $y = 4\sqrt{x} + \frac{2}{\sqrt{x}}$ .
- Obtain an expression for  $\frac{dy}{dx}$ .
  - A point is moving along the curve in such a way that the  $x$ -coordinate is increasing at a constant rate of 0.12 units per second. Find the rate of change of the  $y$ -coordinate when  $x = 4$ . [J12/P12/Q2]
33. The curve  $y = \frac{10}{2x+1} - 2$  intersects the  $x$ -axis at  $A$ . The tangent to the curve at  $A$  intersects the  $y$ -axis at  $C$ .
- Show that the equation of  $AC$  is  $5y + 4x = 8$ .
  - Find the distance  $AC$ . [J12/P13/Q7]
34. An oil pipeline under the sea is leaking oil and a circular patch of oil has formed on the surface of the sea. At midday the radius of the patch of oil is 50 m and is increasing at a rate of 3 metres per hour. Find the rate at which the area of the oil is increasing at midday. [N12/P11/Q3]
35. A curve has equation  $y = 2x + \frac{1}{(x-1)^2}$ . Verify that the curve has a stationary point at  $x = 2$  and determine its nature. [N12/P11/Q5]

36.

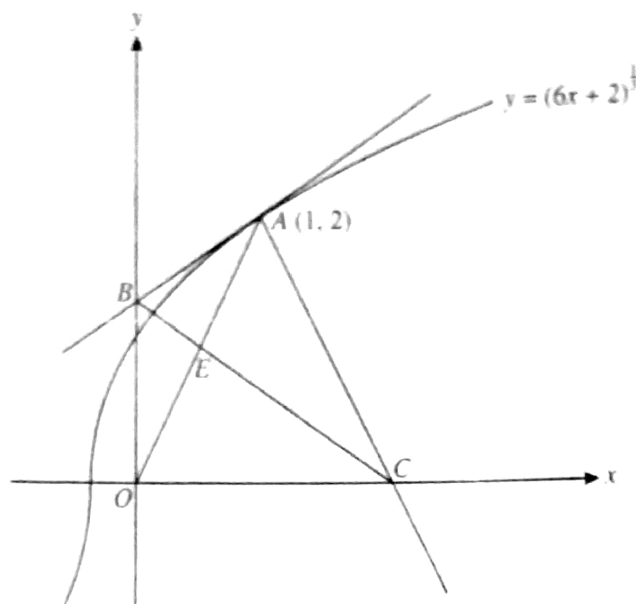

The diagram shows the curve  $y = (6x + 2)^{\frac{1}{3}}$  and the point  $A(1, 2)$  which lies on the curve. The tangent to the curve at  $A$  cuts the  $y$ -axis at  $B$  and the normal to the curve at  $A$  cuts the  $x$ -axis at  $C$ .

- (i) Find the equation of the tangent  $AB$  and the equation of the normal  $AC$ .
- (ii) Find the distance  $BC$ .
- (iii) Find the coordinates of the point of intersection,  $E$ , of  $OA$  and  $BC$ , and determine whether  $E$  is the mid-point of  $OA$ . [N12/P11/Q11]

37. The diagram shows a plan for a rectangular park  $ABCD$ , in which  $AB = 40$  m and  $AD = 60$  m. Points  $X$  and  $Y$  lie on  $BC$  and  $CD$  respectively and  $AX$ ,  $XY$  and  $YA$  are paths that surround a triangular playground. The length of  $DY$  is  $x$  m and the length of  $XC$  is  $2x$  m.

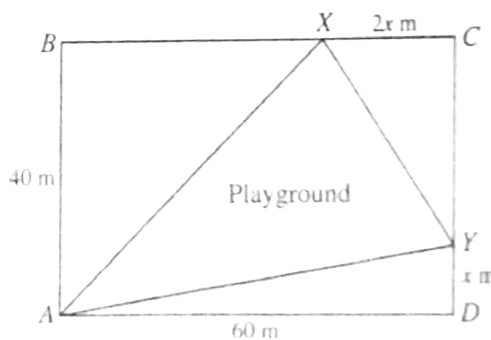

- (i) Show that the area,  $A$  m<sup>2</sup>, of the playground is given by  $A = x^2 - 30x + 1200$ .
- (ii) Given that  $x$  can vary, find the minimum area of the playground. [N12/P12/Q3]

38. A curve is defined for  $x > 0$  and is such that  $\frac{dy}{dx} = x + \frac{4}{x^2}$ . The point  $P(4, 8)$  lies on the curve.

- (i) Find the equation of the curve.
- (ii) Show that the gradient of the curve has a minimum value when  $x = 2$  and state this minimum value. [N12/P12/Q10]

39. It is given that  $f(x) = \frac{1}{x^3} - x^3$ , for  $x > 0$ . Show that  $f$  is a decreasing function. [N12/P13/Q2]

40. A curve is such that

$$\frac{dy}{dx} = 2(3x + 4)^{\frac{1}{2}} - 6x - 8$$

(i) Find  $\frac{d^2y}{dx^2}$ .

(ii) Verify that the curve has a stationary point when  $x = -1$  and determine its nature.

(iii) It is now given that the stationary point on the curve has coordinates  $(-1, 5)$ . Find the equation of the curve. [N12/P13/Q8]

41. It is given that  $f(x) = (2x - 5)^3 + x$ , for  $x \in \mathbb{R}$ . Show that  $f$  is an increasing function. [J13/P11/Q1]

42. A curve has equation  $y = f(x)$  and is such that  $f'(x) = 3x^{\frac{1}{2}} + 3x^{-\frac{1}{2}} - 10$

(i) By using the substitution  $u = x^{\frac{1}{2}}$ , or otherwise, find the values of  $x$  for which the curve  $y = f(x)$  has stationary points.

(ii) Find  $f''(x)$  and hence, or otherwise, determine the nature of each stationary point.

(iii) It is given that the curve  $y = f(x)$  passes through the point  $(4, -7)$ . Find  $f(x)$ . [J13/P11/Q9]

43. The volume of a solid circular cylinder of radius  $r$  cm is  $250\pi$  cm<sup>3</sup>.

(i) Show that the total surface area,  $S$  cm<sup>2</sup>, of the cylinder is given by

$$S = 2\pi r^2 + \frac{500\pi}{r}$$

(ii) Given that  $r$  can vary, find the stationary value of  $S$ .

(iii) Determine the nature of this stationary value. [J13/P12/Q8]

44. The non-zero variables  $x$ ,  $y$  and  $u$  are such that  $u = x^2y$ . Given that  $y + 3x = 9$ , find the stationary value of  $u$  and determine whether this is a maximum or a minimum value. [J13/P13/Q6]

45. A curve has equation  $y = f(x)$ . It is given that  $f'(x) = \frac{1}{\sqrt{x+6}} + \frac{6}{x^2}$  and that  $f(3) = 1$ . Find  $f(x)$ . [N13/P11/Q2]

46. The inside lane of a school running track consists of two straight sections each of length  $x$  metres, and two semicircular sections each of radius  $r$  metres, as shown in the diagram. The straight sections are perpendicular to the diameters of the semicircular sections. The perimeter of the inside lane is 400 metres

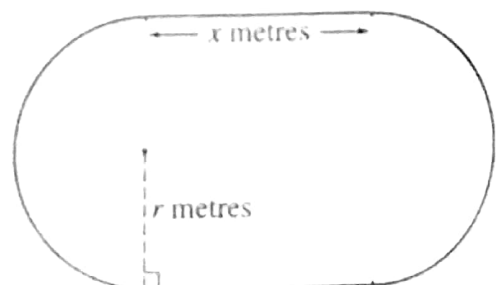



- (i) Show that the area,  $A \text{ m}^2$ , of the region enclosed by the inside lane is given by  $A = 400r - \pi r^2$ .
- (ii) Given that  $x$  and  $r$  can vary, show that, when  $A$  has a stationary value, there are no straight sections in the track. Determine whether the stationary value is a maximum or a minimum.

[N13/P11/Q8]

47. In the diagram,  $S$  is the point  $(0, 12)$  and  $T$  is the point  $(16, 0)$ . The point  $Q$  lies on  $ST$ , between  $S$  and  $T$ , and has coordinates  $(x, y)$ . The points  $P$  and  $R$  lie on the  $x$ -axis and  $y$ -axis respectively and  $OPQR$  is a rectangle.

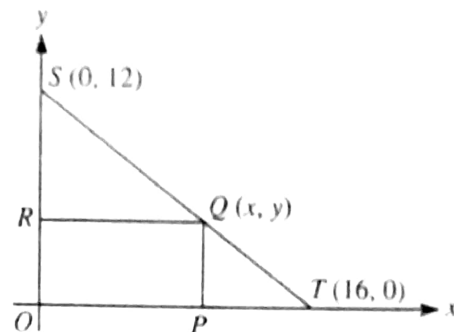

- (i) Show that the area,  $A$ , of the rectangle

$$OPQR \text{ is given by } A = 12x - \frac{3}{4}x^2.$$

- (ii) Given that  $x$  can vary, find the stationary value of  $A$  and determine its nature.

[N13/P12/Q6]

48. A curve has equation  $y = \frac{k^2}{x+2} + x$ , where  $k$  is a positive constant. Find, in terms of  $k$ , the values of  $x$  for which the curve has stationary points and determine the nature of each stationary point.

[N13/P13/Q9]

49. A curve has equation  $y = \frac{4}{(3x+1)^2}$ . Find the equation of the tangent to the curve at the point where the line  $x = -1$  intersects the curve.

[J14/P11/Q4]

50. A curve is such that  $\frac{dy}{dx} = x^{\frac{1}{2}} - x^{-\frac{1}{2}}$ . The curve passes through the point  $(4, \frac{2}{3})$ .

- (i) Find the equation of the curve.

- (ii) Find  $\frac{d^2y}{dx^2}$

- (iii) Find the coordinates of the stationary point and determine its nature.

[J14/P11/Q12]

51. A curve is such that  $\frac{dy}{dx} = \frac{12}{\sqrt{4x+a}}$ , where  $a$  is a constant. The point  $P(2, 14)$  lies on the curve and the normal to the curve at  $P$  is  $3y + x = 5$ .

- (i) Show that  $a = 8$ .

- (ii) Find the equation of the curve.

[J14/P13/Q6]

52. The base of a cuboid has sides of length  $x$  cm and  $3x$  cm. The volume of the cuboid is  $288 \text{ cm}^3$ .

(i) Show that the total surface area of the cuboid,  $A \text{ cm}^2$ , is given by

$$A = 6x^2 + \frac{768}{x}$$

(ii) Given that  $x$  can vary, find the stationary value of  $A$  and determine its nature. [J14/P13/Q9]

53. The function  $f$  is defined for  $x > 0$  and is such that  $f'(x) = 2x - \frac{2}{x^2}$ . The curve  $y = f(x)$  passes through the point  $P(2, 6)$ .

(i) Find the equation of the normal to the curve at  $P$ .

(ii) Find the equation of the curve.

(iii) Find the  $x$ -coordinate of the stationary point and state with a reason whether this point is a maximum or a minimum. [N14/P11/Q9]

54. A curve has equation  $y = \frac{12}{3-2x}$ .

(i) Find  $\frac{dy}{dx}$ .

A point moves along this curve. As the point passes through  $A$ , the  $x$ -coordinate is increasing at a rate of 0.15 units per second and the  $y$ -coordinate is increasing at a rate of 0.4 units per second.

(ii) Find the possible  $x$ -coordinates of  $A$ . [N14/P12/Q4]

55. The equation of a curve is  $y = x^3 + ax^2 + bx$ , where  $a$  and  $b$  are constants.

(i) In the case where the curve has no stationary point, show that  $a^2 < 3b$ .

(ii) In the case where  $a = -6$  and  $b = 9$ , find the set of values of  $x$  for which  $y$  is a decreasing function of  $x$ . [N14/P12/Q6]

56. A curve is such that  $\frac{d^2y}{dx^2} = \frac{24}{x^3} - 4$ . The curve has a stationary point at  $P$  where  $x = 2$ .

(i) State, with a reason, the nature of this stationary point.

(ii) Find an expression for  $\frac{dy}{dx}$ .

(iii) Given that the curve passes through the point  $(1, 13)$ , find the coordinates of the stationary point  $P$ . [N14/P12/Q10]

57. A curve  $y = f(x)$  has a stationary point at  $(3, 7)$  and is such that  $f''(x) = 36x^{-3}$ .

(i) State, with a reason, whether this stationary point is a maximum or a minimum.

(ii) Find  $f'(x)$  and  $f(x)$ .

[N14/P13/Q8]

68. A curve is such that  $\frac{dy}{dx} = 2 - 8(3x + 4)^{-\frac{1}{2}}$ .

- (i) A point  $P$  moves along the curve in such a way that the  $x$ -coordinate is increasing at a constant rate of 0.3 units per second. Find the rate of change of the  $y$ -coordinate as  $P$  crosses the  $y$ -axis.

The curve intersects the  $y$ -axis where  $y = \frac{4}{3}$ .

- (ii) Find the equation of the curve.

[J16/P11/Q4]

69. A farmer divides a rectangular piece of land into 8 equal-sized rectangular sheep pens as shown in the diagram. Each sheep pen measures  $x$  m by  $y$  m and is fully enclosed by metal fencing. The farmer uses 480 m of fencing.

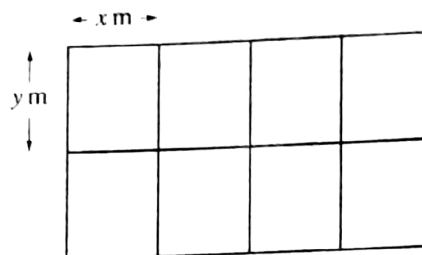

- (i) Show that the total area of land used for the sheep pens,  $A$  m<sup>2</sup>, is given by

$$A = 384x - 9.6x^2.$$

- (ii) Given that  $x$  and  $y$  can vary, find the dimensions of each sheep pen for which the value of  $A$  is a maximum.

(There is no need to verify that the value of  $A$  is a maximum.)

[J16/P11/Q5]

70. The diagram shows the part of the curve  $y = \frac{8}{x} + 2x$  for  $x > 0$ , and the minimum point  $M$ .

- (i) Find expressions for  $\frac{dy}{dx}$ ,  $\frac{d^2y}{dx^2}$  and  $\int y^2 dx$ .

- (ii) Find the coordinates of  $M$  and determine the coordinates and nature of the stationary point on the part of the curve for which  $x < 0$ .

- (iii) Find the volume obtained when the region bounded by the curve, the  $x$ -axis and the lines  $x = 1$  and  $x = 2$  is rotated through  $360^\circ$  about the  $x$ -axis.

[J16/P12/Q10]

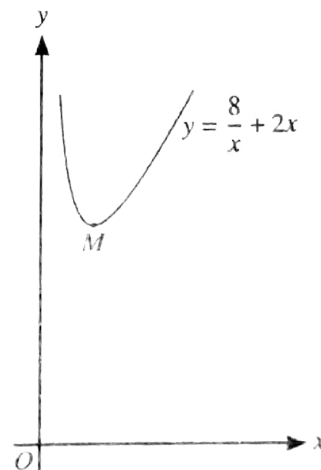

71. A curve has equation  $y = 8x + (2x - 1)^{-1}$ . Find the values of  $x$  at which the curve has a stationary point and determine the nature of each stationary point, justifying your answers.

[J16/P13/Q5]

72. The point  $P(x, y)$  is moving along the curve  $y = x^2 - \frac{10}{3}x^{\frac{3}{2}} + 5x$  in such a way that the rate of change of  $y$  is constant. Find the values of  $x$  at the points at which the rate of change of  $x$  is equal to half the rate of change of  $y$ .

[J16/P13/Q7]

73. A curve has equation  $y = f(x)$  and it is given that  $f'(x) = 3x^{\frac{1}{2}} - 2x^{-\frac{1}{2}}$ . The point  $A$  is the only point on the curve at which the gradient is  $-1$ .
- Find the  $x$ -coordinate of  $A$ .
  - Given that the curve also passes through the point  $(4, 10)$ , find the  $y$ -coordinate of  $A$ , giving your answer as a fraction.
- [N16/P11/Q10]
74. The point  $P(3, 5)$  lies on the curve  $y = \frac{1}{x-1} - \frac{9}{x-5}$ .
- Find the  $x$ -coordinate of the point where the normal to the curve at  $P$  intersects the  $x$ -axis.
  - Find the  $x$ -coordinate of each of the stationary points on the curve and determine the nature of each stationary point, justifying your answers.
- [N16/P11/Q11]
75. The equation of a curve is  $y = 2 + \frac{3}{2x-1}$ .
- Obtain an expression for  $\frac{dy}{dx}$ .
  - Explain why the curve has no stationary points.
- At the point  $P$  on the curve,  $x = 2$ .
- Show that the normal to the curve at  $P$  passes through the origin.
  - A point moves along the curve in such a way that its  $x$ -coordinate is decreasing at a constant rate of  $0.06$  units per second. Find the rate of change of the  $y$ -coordinate as the point passes through  $P$ .
- [N16/P12/Q7]
76. The function  $f$  is such that  $f(x) = x^3 - 3x^2 - 9x + 2$  for  $x > n$ , where  $n$  is an integer. It is given that  $f$  is an increasing function. Find the least possible value of  $n$ .
- [N16/P13/Q4]
77. A curve is such that  $\frac{dy}{dx} = \frac{2}{a}x^{-\frac{1}{2}} + ax^{-\frac{3}{2}}$ , where  $a$  is a positive constant. The point  $(a^2, 3)$  lies on the curve. Find, in terms of  $a$ ,
- the equation of the tangent to the curve at  $A$ , simplifying your answer,
  - the equation of the curve.
- It is now given that  $B(16, 8)$  also lies on the curve.
- Find the value of  $a$  and, using this value, find the distance  $AB$ .
- [N16/P13/Q10]

# ANSWERS

## Topic 9 - Differentiation

5.  $\frac{dy}{dx} = -\frac{k}{x^2}$

$\Rightarrow -3 = -\frac{k}{(2)^2} \Rightarrow k = 12$

6. (i)  $\frac{dy}{dx} = 3x^2 - 6x - 9 = 0$

$\Rightarrow x^2 - 2x - 3 = 0 \Rightarrow x = 3, \text{ or } x = -1$

$\therefore$  minimum point is (3, 0)

Subst (3, 0) into eq of curve gives  $k = 27$

(ii) Subst  $x = -1$  into the equation of curve, max. point is (-1, 32)

(iii)  $\frac{dy}{dx} < 0$

$\Rightarrow 3x^2 - 6x - 9 < 0 \Rightarrow -1 < x < 3$

(iv) Area =  $\int_0^3 (x^3 - 3x^2 - 9x + 27) dx$   
 $= 33\frac{3}{4}$  sq. units

7. (i)  $\frac{dy}{dx} = \frac{12}{(5-2x)^2}$

at  $x = 1, \frac{dy}{dx} = \frac{4}{3}$

(ii)  $\frac{dy}{dt} = \frac{dy}{dx} \times \frac{dx}{dt}$

$\Rightarrow 0.02 = \frac{4}{3} \times \frac{dx}{dt} \Rightarrow \frac{dx}{dt} = 0.015$  units/sec

(iii) Volume =  $\pi \int_0^1 \left(\frac{6}{5-2x}\right)^2 dx$   
 $= 36\pi \int_0^1 (5-2x)^{-2} dx = \frac{12}{5}\pi$  units<sup>3</sup>.

8. (i) By pythagoras, height of the  $\Delta = 3x$  cm

Total surface area =  $2\left(\frac{1}{2}(8x)(3x)\right) + 2(5xy)$

$\Rightarrow 200 = 24x^2 + 10xy \Rightarrow y = \frac{200 - 24x^2}{10x}$

(ii)  $V = \text{area of } \Delta \times \text{height}$

$= \left(\frac{1}{2}(8x)(3x)\right) \times \left(\frac{200 - 24x^2}{10x}\right)$   
 $= 240x - 28.8x^3$

(iii)  $\frac{dV}{dx} = 240 - 86.4x^2 = 0$

$\Rightarrow x^2 = 2.7778 \Rightarrow x = 1.67$

(iv) At  $x = 1.667, \frac{d^2V}{dx^2} < 0, \therefore$  Maximum

9. (i)  $\frac{dy}{dx} = 2 - \frac{16}{x^3}, \frac{d^2y}{dx^2} = \frac{48}{x^4}$

(ii)  $2 - \frac{16}{x^3} = 0 \Rightarrow x = 2$

$\Rightarrow y = 2(2) + \frac{8}{(2)^2} = 6$

$\therefore$  stationary point is (2, 6)

at  $x = 2, \frac{d^2y}{dx^2} > 0, \therefore$  (2, 6) is a min. point.

(iii) At (-2, -2),  $\frac{dy}{dx} = 2 - \frac{16}{(-2)^3} = 4$

$\therefore$  gradient of the normal =  $-\frac{1}{4}$

equation of the normal:  $y + 2 = -\frac{1}{4}(x + 2)$

for  $x$ -intercept put  $y = 0, \Rightarrow x = -10$

$\therefore$  the normal cuts the  $x$ -axis at (-10, 0)

(iv) Area =  $\int_1^2 y dx$

$= \int_1^2 (2x + 8x^{-2}) dx = 7$  sq. units

10. (i)  $\frac{dy}{dx} = 24(x^2 - 3x + 2)$

$\frac{d^2y}{dx^2} = \frac{d}{dx}(24(x^2 - 3x + 2)) = 24(2x - 3)$



(ii)  $\frac{dy}{dx} = 24(x^2 - 3x + 2) = 0$   
 $\Rightarrow 24(x-2)(x-1) = 0 \Rightarrow x=1, x=2$   
 at  $x=1, \frac{d^2y}{dx^2} < 0, \therefore$  maximum point  
 at  $x=2, \frac{d^2y}{dx^2} > 0, \therefore$  minimum point.

11. (i) Perimeter of square =  $4x$   
 perimeter of circle =  $2\pi r$   
 $\therefore 4x + 2\pi r = 80 \Rightarrow r = \frac{40-2x}{\pi}$   
 $A = x^2 + \pi r^2$   
 $= x^2 + \pi \left( \frac{40-2x}{\pi} \right)^2$   
 $= \frac{(\pi+4)x^2 - 160x + 1600}{\pi}$

(ii)  $\frac{dA}{dx} = \frac{2(\pi+4)x - 160}{\pi} = 0$   
 $\Rightarrow \frac{2(\pi+4)x - 160}{\pi} = 0 \Rightarrow x = 11.2 \text{ cm}$

12. (i)  $\frac{dy}{dx} = 3x^2 - 12x + 9 = 0$   
 $\Rightarrow 3x^2 - 12x + 9 = 0 \Rightarrow x=1, \text{ and } x=3$   
 when  $x=1, y=4, \therefore A(1, 4)$   
 when  $x=3, y=0, \therefore B(3, 0)$

(ii) At C,  $\frac{dy}{dx} = -3 \Rightarrow$  grad. of normal =  $\frac{1}{3}$   
 equation of normal is:  
 $y-2 = \frac{1}{3}(x-2) \Rightarrow 3y-x=4$

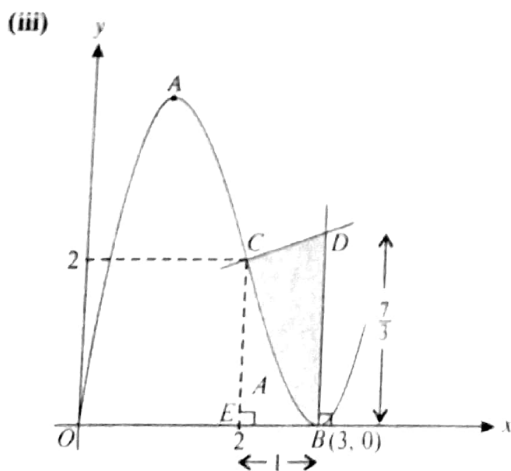

Subst.  $x=3$  into eq. of CD,  $\Rightarrow D(3, \frac{7}{3})$

Area of BDC =  $\frac{1}{2}(1)\left(2 + \frac{7}{3}\right) = \frac{13}{6} \text{ units}^2$

Area under the curve =  $\int_2^3 y \, dx$

$\Rightarrow A = \int_2^3 (x^3 - 6x^2 + 9x) \, dx = \frac{3}{4} \text{ units}^2$

Area of Shaded Region =  $\frac{13}{6} - \frac{3}{4} = 1\frac{5}{12} \text{ unit}^2$

13. (i)  $\frac{dy}{dx} = \frac{-24x}{(x^2+3)^2}$

(ii) At  $x=1, \text{ grad.} = -\frac{3}{2}, \therefore$  grad. of normal =  $\frac{2}{3}$   
 Equation of normal:

$y-3 = \frac{2}{3}(x-1) \Rightarrow 3y-2x=7$

(iii)  $\frac{dy}{dt} = \frac{dy}{dx} \times \frac{dx}{dt}$   
 $= -\frac{3}{2} \times 0.012 = -0.018 \text{ units/sec}$

14. (i) Perimeter of the sector POQ = 50 cm  
 $\Rightarrow r+r+r\theta = 50 \Rightarrow \theta = \frac{50}{r} - 2$

Area,  $A = \frac{1}{2}r^2 \left( \frac{50}{r} - 2 \right) = 25r - r^2$

(ii)  $\frac{dA}{dr} = 25 - 2r = 0 \Rightarrow r = 12.5 \text{ cm}$   
 stationary value =  $25(12.5) - (12.5)^2 = 156.25$   
 $\frac{d^2A}{dr^2} = -2 < 0, \therefore$  St. value is a maximum

15. (i) Point A is (3, 0),  
 At  $x=3, \frac{dy}{dx} = \frac{36}{(2(3)+3)^2} = \frac{4}{9}$

gradient of normal =  $-\frac{4}{9}$

Equation of normal AC is:

$y-0 = -\frac{4}{9}(x-3) \Rightarrow 9x+4y=27$

(ii) Subst.  $x=0$  into eq. of curve gives,  $B(0, -4)$   
 Subst.  $x=0$  into eq. of AC gives,  $C(0, \frac{27}{4})$

Length of BC,  $|BC| = 10.75$

16. (i) Total surface area =  $2x^2 + 4xh$   
 $\Rightarrow 2x^2 + 4xh = 96 \Rightarrow h = \frac{48 - x^2}{2x}$   
 $V = \text{base area} \times h$   
 $= x^2 \left( \frac{48 - x^2}{2x} \right) = 24x - \frac{1}{2}x^3$
- (ii)  $\frac{dV}{dx} = 24 - \frac{3}{2}x^2 = 0 \Rightarrow x = 4$   
 $\therefore$  Stationary value of  $V = 24(4) - \frac{1}{2}(4)^3 = 64$
- (iii) At  $x = 4$ ,  $\frac{d^2V}{dx^2} = -12 < 0$ ,  $\therefore$  Maximum.

17. (i)  $\frac{dy}{dx} = (2x-3)^2 - 4$
- (ii) At  $x = 0$ ,  $\frac{dy}{dx} = 5$   
 the curve meets the  $y$ -axis at  $(0, -\frac{9}{2})$   
 $\therefore$  equation is:  $2y - 10x + 9 = 0$
- (iii) For increasing function,  $\frac{dy}{dx} > 0$   
 $\Rightarrow (2x-3)^2 - 4 > 0 \Rightarrow (2x-1)(2x-5) > 0$   
 $\therefore x < \frac{1}{2}, x > \frac{5}{2}$

18. (i)  $\frac{dy}{dx} = 4 - 2x$   
 At  $x = 3$ ,  $m = -2 \Rightarrow m$  of normal =  $\frac{1}{2}$   
 Equation:  $y - 6 = \frac{1}{2}(x - 3) \Rightarrow 2y = x + 9$
- (ii)  $A(0, \frac{9}{2}), B(-9, 0)$   
 $\therefore$  mid point of  $AB = \left( -\frac{9}{2}, \frac{9}{4} \right)$
- (iii) Equation of  $AB$ :  $2y = x + 9$   
 Equation of curve:  $y = 3 + 4x - x^2$   
 solving simultaneously gives,  $x = \frac{1}{2}, y = \frac{19}{4}$   
 $\therefore$  normal meets the curve again at  $\left( \frac{1}{2}, \frac{19}{4} \right)$

19. (i)  $2x + 2y + \frac{\pi x}{2} = 60 \Rightarrow y = 30 - x - \frac{\pi x}{4}$

- (ii)  $A = xy + \frac{1}{4}\pi x^2$   
 $= x \left( 30 - x - \frac{\pi x}{4} \right) + \frac{1}{4}\pi x^2 = 30x - x^2$
- (iii)  $\frac{dA}{dx} = 30 - 2x = 0 \Rightarrow x = 15$
- (iv) Stationary value of  $A = 30(15) - 15^2 = 225$   
 $\frac{d^2A}{dx^2} = -2 < 0$ ,  $\therefore$  maximum
20. (i)  $\frac{dx}{dt} = \frac{0.7}{\sqrt{2t-1}}$
- (ii) When  $t = 5$ ,  $\frac{dx}{dt} = \frac{0.7}{\sqrt{2(5)-1}} = 0.233$   
 $\therefore$  rate of growth = 0.233 metres per year

21. (i) Volume of tank =  $4 \text{ m}^3$   
 $\Rightarrow (x) \left( \frac{1}{2}x \right) (h) = 4 \Rightarrow h = \frac{8}{x^2}$   
 $A = (x) \left( \frac{1}{2}x \right) + 2xh + 2 \left( \frac{1}{2}x \right) (h) + \left( \frac{4}{5}x \right) \left( \frac{5}{4}x \right)$   
 $= \frac{3}{2}x^2 + 3xh = \frac{3}{2}x^2 + 3x \left( \frac{8}{x^2} \right) = \frac{3}{2}x^2 + \frac{24}{x}$
- (ii)  $\frac{dA}{dx} = 3x - \frac{24}{x^2} = 0 \Rightarrow x = 2$   
 At  $x = 2$ ,  $\frac{d^2A}{dx^2} = 9 > 0$ ,  $\therefore A$  is minimum

22. (i)  $\frac{dy}{dx} = -\frac{1}{(x-3)^2} + 1$ ,  $\frac{d^2y}{dx^2} = \frac{2}{(x-3)^3}$
- (ii)  $\frac{dy}{dx} = -\frac{1}{(x-3)^2} + 1 = 0 \Rightarrow x = 4$  or  $2$   
 When  $x = 2$ ,  $y = \frac{1}{2-3} + 2 = 1$ ,  $\therefore A(2, 1)$   
 When  $x = 4$ ,  $y = \frac{1}{4-3} + 4 = 5$ ,  $\therefore B(4, 5)$   
 when  $x = 2$ ,  $\frac{d^2y}{dx^2} = -2 < 0$ ,  $\therefore A$  is maximum  
 when  $x = 4$ ,  $\frac{d^2y}{dx^2} = 2 > 0$ ,  $\therefore B$  is minimum

23.  $\frac{dV}{dr} = 4\pi r^2$ , At  $r = 10$ ,  $\frac{dV}{dr} = 400\pi$   
 $\frac{dr}{dt} = \frac{dV}{dt} \times \frac{dr}{dV} = \frac{1}{8\pi} \text{ cm/s}$

AL Mathematics (P1)

24. (i)  $z = 3x + 2\left(\frac{600}{x}\right) \Rightarrow z = 3x + \frac{1200}{x}$
- (ii)  $\frac{dz}{dx} = 3 - \frac{1200}{x^2} = 0 \Rightarrow x = 20$   
 $\therefore$  Stationary value of  $z = 3(20) + \frac{1200}{20} = 120$   
 At  $x = 20$ ,  $\frac{d^2z}{dx^2} = 0.3 > 0$ ,  $\therefore$  minimum
25. (i)  $\frac{dy}{dx} = -\frac{12}{(3x-4)^2}$ , at  $x = 2$ ,  $\frac{dy}{dx} = -3$   
 Equation:  $y - 2 = -3(x - 2) \Rightarrow 3x + y = 8$
- (ii) Gradient of the tangent =  $\tan \theta$   
 $\Rightarrow \tan \theta = -3 \Rightarrow \theta = 108.4^\circ$
26.  $\frac{dy}{dx} = 9x^2 - 12x + 4 = (3x - 2)^2$   
 $\therefore$  Gradient is never negative
27. (i) Perimeter = 48  
 $\Rightarrow 8x + 6y = 48 \Rightarrow y = \frac{24 - 4x}{3}$
- (ii)  $A = 3xy + 3xy$   
 $= 6x\left(\frac{24 - 4x}{3}\right) = 48x - 8x^2$
- (iii)  $\frac{dA}{dx} = 48 - 16x = 0 \Rightarrow x = 3$   
 $\therefore$  Area,  $A = 48(3) - 8(3)^2 = 72 \text{ m}^2$   
 $\frac{d^2A}{dx^2} = -16 < 0$ ,  $\therefore$  Area is maximum
28. (i) Grad. of the normal line =  $-\frac{1}{3}$   
 $\Rightarrow$  gradient of tangent to curve = 3  
 $\Rightarrow 5 - \frac{8}{x^2} = 3 \Rightarrow x = \pm 2$   
 Subst.  $x = 2$  into line, gives,  $y = 5$   
 $\therefore$  coordinates of  $P(2, 5)$
- (ii)  $\int dy = \int (5 - 8x^{-2}) dx \Rightarrow y = 5x + \frac{8}{x} + K$   
 Subst.  $P(2, 5)$  gives,  $K = -9$   
 $\therefore$  equation of the curve is:  $y = 5x + \frac{8}{x} - 9$
29. (i)  $P(3, -10)$  is a stationary point,  $\Rightarrow f'(3) = 0$   
 $\Rightarrow 2(3)^2 + k(3) - 12 = 0 \Rightarrow k = -2$   
 now,  $f'(x) = 2x^2 - 2x - 12 = 0$   
 $\Rightarrow (x - 3)(x + 2) = 0 \Rightarrow x = 3$  or  $-2$   
 $\therefore$   $x$ -coordinate of  $Q = -2$
- (ii)  $f''(x) = 4x - 2$   
 at  $x = 3$ ,  $f''(x) = 10$ ,  $\therefore P$  is minimum.  
 at  $x = -2$ ,  $f''(x) = -10$ ,  $\therefore Q$  is maximum
- (iii)  $\int f'(x) dx = \int (2x^2 - 2x - 12) dx$   
 $\Rightarrow f(x) = \frac{2}{3}x^3 - x^2 - 12x + K$   
 Subst.  $P(3, -10)$  gives,  $K = 17$   
 $\therefore f(x) = \frac{2}{3}x^3 - x^2 - 12x + 17$
30.  $k = \frac{M}{r^3} = \frac{3.2}{10^3} = 0.0032$   
 $\frac{dM}{dt} = \frac{dM}{dr} \times \frac{dr}{dt}$   
 $= 3(0.0032)(10)^2 \times 0.1 = 0.096$
31. (i)  $\frac{dy}{dx} < 5$   
 $\Rightarrow 3x^2 - 4x - 4 < 0 \Rightarrow (x - 2)(3x + 2) < 0$   
 $\Rightarrow -\frac{2}{3} < x < 2$
- (ii)  $\frac{dy}{dx} = 3x^2 - 4x + 1 = 0 \Rightarrow x = \frac{1}{3}$  or  $1$   
 when  $x = \frac{1}{3}$ ,  $f\left(\frac{1}{3}\right) = \frac{4}{27}$ ,  
 when  $x = 1$ ,  $f(1) = 0$ ,  
 at  $x = \frac{1}{3}$ ,  $\frac{d^2y}{dx^2} = -2$ ,  $\therefore \left(\frac{1}{3}, \frac{4}{27}\right)$  is maximum  
 at  $x = 1$ ,  $\frac{d^2y}{dx^2} = 2$ ,  $\therefore (1, 0)$  is minimum
32. (i)  $\frac{dy}{dx} = \frac{2x-1}{x\sqrt{x}}$
- (ii) When  $x = 4$ ,  $\frac{dy}{dx} = \frac{2(4)-1}{4\sqrt{4}} = \frac{7}{8}$   
 $\frac{dy}{dt} = \frac{dy}{dx} \times \frac{dx}{dt}$   
 $= \frac{7}{8} \times 0.12 = 0.105$  units/second
33. (i) Point  $A(2, 0)$ , at  $x = 2$ ,  $\frac{dy}{dx} = -\frac{4}{5}$   
 Equation:  $y - 0 = -\frac{4}{5}(x - 2) \Rightarrow 4x + 5y = 8$
- (ii) Point  $C$  is  $\left(0, \frac{8}{5}\right)$   
 $|AC| = \sqrt{(2-0)^2 + \left(0 - \frac{8}{5}\right)^2} = 2.56$  units.

34.  $A = \pi r^2 \Rightarrow \frac{dA}{dr} = 2\pi r$

$$\frac{dA}{dt} = \frac{dA}{dr} \times \frac{dr}{dt}$$

$$= 2\pi(50) \times 3 = 300\pi$$

35.  $\frac{dy}{dx} = 2 - \frac{2}{(x-1)^3}$

at  $x = 2$ ,  $\frac{dy}{dx} = 2 - \frac{2}{(2-1)^3} = 0$  (verified)

at  $x = 2$ ,  $\frac{d^2y}{dx^2} = 6 > 0$ ,  $\therefore$  Minimum.

36. (i)  $\frac{dy}{dx} = 2(6x+2)^{-\frac{2}{3}}$

At  $x = 1$ ,  $\frac{dy}{dx} = \frac{1}{2}$ ,  $\Rightarrow$  grad of normal =  $-2$

$\therefore$  Equation of AB:  $2y - x = 3$

$\therefore$  Equation of AC:  $y + 2x = 4$

(ii) Subst.  $x = 0$  into eq. of AB gives,  $B(0, \frac{3}{2})$

Subst.  $y = 0$  into eq. of AC gives,  $C(2, 0)$

Distance BC:  $|BC| = \sqrt{6.25} = 2.5$  units.

(iii) Equation of OA:  $y = 2x$

Equation of BC:  $4y + 3x = 6$

Solving simultaneously gives,  $E(\frac{6}{11}, \frac{12}{11})$

Mid-point of OA =  $(\frac{1}{2}, 1)$

$\Rightarrow E$  is not a mid-point of OA.

37. (i)  $A = \text{area of } ABCD - \text{area of } (\triangle ABX + \triangle XCY + \triangle YDA)$

$$= (60 \times 40) - \left( \frac{1}{2}(60-2x)(40) + \frac{1}{2}(2x)(40-x) + \frac{1}{2}(60)(x) \right)$$

$$= 2400 - (1200 - 40x + 40x - x^2 + 30x)$$

$$= x^2 - 30x + 1200$$

(ii)  $\frac{dA}{dx} = 2x - 30 = 0 \Rightarrow x = 15$

Min. area =  $(15)^2 - 30(15) + 1200 = 975 \text{ m}^2$

38. (i)  $\int dy = \int (x + 4x^{-2}) dx \Rightarrow y = \frac{x^2}{2} - \frac{4}{x} + K$

Subst.  $P(4, 8)$  gives,  $K = 1$

$\therefore$  equation of the curve:  $y = \frac{x^2}{2} - \frac{4}{x} + 1$

(ii)  $\frac{d^2y}{dx^2} = 1 - \frac{8}{x^3}$ , at  $x = 2$ ,  $\frac{d^2y}{dx^2} = 1 - \frac{8}{2^3} = 0$

Also at  $x = 2$ ,  $\frac{d^3y}{dx^3} = \frac{3}{2} > 0$

$\therefore$  the gradient is minimum at  $x = 2$ .

Minimum value of grad. is:  $\frac{dy}{dx} = 2 + \frac{4}{2^2} = 3$

39.  $f'(x) = -\frac{3}{x^4} - 3x^2 = -3\left(\frac{1}{x^4} + x^2\right)$

$\Rightarrow f'(x) < 0$  for all values of  $x$ .

Thus,  $f(x)$  is a decreasing function.

40. (i)  $\frac{d^2y}{dx^2} = 9(3x+4)^{\frac{1}{2}} - 6$

(ii) At  $x = -1$ ,  $\frac{dy}{dx} = 2(-3+4)^{\frac{3}{2}} + 6 - 8 = 0$

$\therefore$  the curve has a stationary point at  $x = -1$

At  $x = -1$ ,  $\frac{d^2y}{dx^2} = 3 (> 0)$ ,  $\therefore$  Minimum

(iii)  $\int dy = \int \left( 2(3x+4)^{\frac{3}{2}} - 6x - 8 \right) dx$

$$y = \frac{4}{15}(3x+4)^{\frac{5}{2}} - 3x^2 - 8x + C$$

Subst.  $P(-1, 5)$  gives,  $K = -\frac{4}{15}$

$\therefore y = \frac{4}{15}(3x+4)^{\frac{5}{2}} - 3x^2 - 8x - \frac{4}{15}$

41.  $f'(x) = 6(2x-5)^2 + 1$

$f'(x) > 0$  for all values of  $x$ .

$\therefore f(x)$  is an increasing function.

42. (i) Using substitution,  $f'(x) = 3u + \frac{3}{u} - 10$

$$3u + \frac{3}{u} - 10 = 0 \Rightarrow 3u^2 - 10u + 3 = 0$$

$$\Rightarrow u = 3 \text{ or } u = \frac{1}{3} \Rightarrow x = 9 \text{ or } x = \frac{1}{9}$$

(ii)  $f''(x) = \frac{3}{2}x^{-\frac{1}{2}} - \frac{3}{2}x^{-\frac{3}{2}}$

$f''(9) = \frac{4}{9} (> 0)$ , point is minimum.

$f''(\frac{1}{9}) = -36 (< 0)$ , point is maximum.

$$(iii) \int f'(x) dx = \int \left( 3x^{\frac{1}{2}} + 6x^{-\frac{1}{2}} - 10 \right) dx$$

$$\Rightarrow f(x) = 2x^{\frac{3}{2}} + 6x^{\frac{1}{2}} - 10x + K$$

$$\text{Subst. } P(4, -7) \text{ gives, } K = 5$$

$$\therefore f(x) = 2x^{\frac{3}{2}} + 6x^{\frac{1}{2}} - 10x + 5$$

43. (i) Volume of cylinder =  $\pi r^2 h$

$$\Rightarrow \pi r^2 h = 250\pi \Rightarrow h = \frac{250}{r^2}$$

$$S = 2\pi r^2 + 2\pi r \left( \frac{250}{r^2} \right) = 2\pi r^2 + \frac{500\pi}{r}$$

$$(ii) \frac{dS}{dr} = 4\pi r - \frac{500\pi}{r^2} = 0 \Rightarrow r = 5 \text{ cm}$$

$$\text{Stationary value} = 2\pi(5)^2 + \frac{500\pi}{5} = 150\pi \text{ cm}^2$$

$$(iii) \frac{d^2S}{dr^2} = 4\pi + \frac{1000\pi}{r^3}$$

$$\text{at } r = 5, \frac{d^2S}{dr^2} = 12\pi (>0)$$

$\therefore$  Stationary value is a minimum value.

$$44. u = x^2(9-3x) = 9x^2 - 3x^3$$

$$\frac{du}{dx} = 18x - 9x^2 = 0 \Rightarrow x = 2$$

$$\therefore \text{Stationary value is: } u = 9(2)^2 - 3(2)^3 = 12$$

$$\text{at } x = 2, \frac{d^2u}{dx^2} = -18, \therefore \text{maximum value.}$$

$$45. \int f'(x) dx = \int \left( \frac{1}{\sqrt{x+6}} + \frac{6}{x^2} \right) dx$$

$$\Rightarrow f(x) = 2\sqrt{x+6} - \frac{6}{x} + K$$

$$\text{Subst. } (3, 1) \text{ gives, } K = -3$$

$$\therefore f(x) = 2\sqrt{x+6} - \frac{6}{x} - 3$$

46. (i) Given perimeter = 400

$$\Rightarrow 2\pi r + 2x = 400 \Rightarrow x = 200 - \pi r$$

$$A = \pi r^2 + 2xr$$

$$= \pi r^2 + 2r(200 - \pi r) = 400r - \pi r^2$$

$$(ii) \frac{dA}{dr} = 400 - 2\pi r = 0 \Rightarrow r = \frac{200}{\pi}$$

$$\text{At this value of } r, x = 200 - \pi \left( \frac{200}{\pi} \right) = 0$$

Since  $x = 0$ , there are no straight sections.

$$\frac{d^2A}{dr^2} = -2\pi, \therefore \text{stationary value is maximum.}$$

47. (i)  $\triangle SRQ$  is similar to  $\triangle SOT$ .

$$\Rightarrow \frac{12-y}{12} = \frac{x}{16} \Rightarrow y = 12 - \frac{3}{4}x$$

$$\text{Area, } A = x \times y$$

$$= x \left( 12 - \frac{3}{4}x \right) = 12x - \frac{3}{4}x^2$$

$$(ii) \frac{dA}{dx} = 12 - \frac{3}{2}x = 0 \Rightarrow x = 8$$

$$\therefore \text{stationary value of } A = 12(8) - \frac{3}{4}(8)^2 = 48$$

$$\frac{d^2A}{dx^2} = -\frac{3}{2} < 0, \therefore \text{Maximum}$$

$$48. \frac{dy}{dx} = -\frac{k^2}{(x+2)^2} + 1 = 0 \Rightarrow (x+2) = \pm k$$

$$\therefore x = k-2, \text{ or } x = -k-2$$

$$\text{At } x = k-2, \frac{d^2y}{dx^2} = \frac{2}{k}, \therefore \text{Minimum}$$

$$\text{At } x = -k-2, \frac{d^2y}{dx^2} = -\frac{2}{k}, \therefore \text{Maximum}$$

$$49. \text{When } x = -1, y = \frac{4}{(-3+1)^2} = 1$$

$$\frac{dy}{dx} = \frac{-24}{(3x+1)^3}, \text{ at } x = -1, \frac{dy}{dx} = 3$$

$$\text{Equation: } y-1 = 3(x+1) \Rightarrow y = 3x+4$$

$$50. (i) \int dy = \int \left( x^{\frac{1}{2}} - x^{-\frac{1}{2}} \right) dx$$

$$\Rightarrow y = \frac{2}{3}x^{\frac{3}{2}} - 2x^{\frac{1}{2}} + K$$

$$\text{Subst. } \left( 4, \frac{2}{3} \right) \text{ gives, } K = -\frac{2}{3}$$

$$\therefore \text{equation of curve: } y = \frac{2}{3}x^{\frac{3}{2}} - 2x^{\frac{1}{2}} - \frac{2}{3}$$

$$(ii) \frac{d^2y}{dx^2} = \frac{1}{2}x^{-\frac{1}{2}} + \frac{1}{2}x^{-\frac{3}{2}}$$

$$(iii) \frac{dy}{dx} = x^{\frac{1}{2}} - x^{-\frac{1}{2}} = 0 \Rightarrow x = 1$$

$$\Rightarrow y = \frac{2}{3}(1)^{\frac{3}{2}} - 2(1)^{\frac{1}{2}} - \frac{2}{3} = -2$$

$$\therefore \text{stationary point is } (1, -2)$$

$$\text{At } x = 1, \frac{d^2y}{dx^2} = 1, \therefore \text{Minimum.}$$



51. (i) Gradient of curve at  $P$ ,  $\frac{dy}{dx} = \frac{12}{\sqrt{8+a}}$

Grad. of the normal line at  $P = -\frac{1}{3}$

$\therefore \left(\frac{12}{\sqrt{8+a}}\right) \times \left(-\frac{1}{3}\right) = -1 \Rightarrow a = 8$

(ii)  $\int dy = \int 12(4x+8)^{\frac{1}{2}} dx$

$\Rightarrow y = 6\sqrt{4x+8} + K$

Subst.  $P(2, 14)$  gives,  $K = -10$

$\therefore$  equation of curve:  $y = 6\sqrt{4x+8} - 10$

52. (i) Volume of the cuboid  $= 3x^2h = 288$

$\Rightarrow 3x^2h = 288 \Rightarrow h = \frac{96}{x^2}$

$A = 6x^2 + 8xh$

$= 6x^2 + 8x\left(\frac{96}{x^2}\right) = 6x^2 + \frac{768}{x}$

(ii)  $\frac{dA}{dx} = 12x - \frac{768}{x^2} = 0 \Rightarrow x^3 = 64 \Rightarrow x = 4$

$\therefore$  Stationary value of  $A = 6(4)^2 + \frac{768}{4} = 288$

At  $x = 4$ ,  $\frac{d^2A}{dx^2} = 36 > 0$ ,  $\therefore$  Minimum

53. (i) At  $x = 2$ , grad.  $f'(x) = 2(2) - \frac{2}{2^2} = \frac{7}{2}$

$\therefore$  grad. of normal  $= -\frac{2}{7}$

Equation of normal:  $7y + 2x = 46$

(ii)  $\int f'(x) dx = \int \left(2x - \frac{2}{x^2}\right) dx$

$\Rightarrow f(x) = x^2 + \frac{2}{x} + K$

Subst.  $P(2, 6)$  gives,  $K = 1$

$\therefore f(x) = x^2 + \frac{2}{x} + 1$

(iii)  $f'(x) = 2x - \frac{2}{x^2} = 0 \Rightarrow x = 1$

$f''(x) = 2 + \frac{4}{x^3}$ ,  $f''(1) = 6$ ,  $\therefore$  Minimum

54. (i)  $\frac{dy}{dx} = \frac{24}{(3-2x)^2}$

(ii) At point  $A$ ,  $\frac{dx}{dt} = 0.15$  and  $\frac{dy}{dt} = 0.4$

using chain rule,  $\frac{dy}{dx} = \frac{0.4}{0.15}$

$\Rightarrow \frac{24}{(3-2x)^2} = \frac{0.4}{0.15} \Rightarrow 3-2x = \pm 3$

$\Rightarrow x = 0$  or  $x = 3$

55. (i)  $\frac{dy}{dx} = 3x^2 + 2ax + b$

The curve has no stationary point,

$\Rightarrow b^2 - 4ac < 0$

$\Rightarrow (2a)^2 - 4(3)(b) < 0 \Rightarrow a^2 < 3b$

(ii)  $y = x^3 - 6x^2 + 9x$

$y$  is a decreasing function if  $\frac{dy}{dx} < 0$

$\Rightarrow 3x^2 - 12x + 9 < 0 \Rightarrow (x-3)(x-1) < 0$

$\therefore 1 < x < 3$

56. (i) At  $x = 2$ ,  $\frac{d^2y}{dx^2} = -1$ ,  $\therefore$  Maximum point.

(ii)  $\int \frac{d}{dx}\left(\frac{dy}{dx}\right) = \int (24x^{-3} - 4) dx$

$\Rightarrow \frac{dy}{dx} = -\frac{12}{x^2} - 4x + C$

$\frac{dy}{dx} = 0$  when  $x = 2$ ,  $\Rightarrow C = 11$

(iii) Integrating both sides of the gradient

$\int dy = \int \left(-\frac{12}{x^2} - 4x + 11\right) dx$

$\Rightarrow y = \frac{12}{x} - 2x^2 + 11x + K$

Subst.  $(1, 13)$  gives  $K = -8$ ,

$\therefore$  eq. of curve:  $y = \frac{12}{x} - 2x^2 + 11x - 8$

Subst.  $x = 2$ , gives  $y = 12$ ,  $\therefore P(2, 12)$

57. (i) At  $x = 3$ ,  $f''(3) = \frac{4}{3}$ ,  $\therefore$  Minimum

(ii)  $f'(x) = \int 36x^{-3} dx \Rightarrow f'(x) = -18x^{-2} + K$

$f'(x) = 0$  when  $x = 3$ ,  $\Rightarrow K = 2$

$\therefore f'(x) = -18x^{-2} + 2$

Also,  $f(x) = \int (-18x^{-2} + 2) dx$

$\Rightarrow f(x) = 18x^{-1} + 2x + C$

Subst.  $(3, 7)$  gives,  $C = -5$

$\therefore f(x) = \frac{18}{x} + 2x - 5$

AL Mathematics (P1)

58.  $\frac{dy}{dx} = \frac{14}{3}x(7x^2 + 1)^{-\frac{2}{3}}$ , at  $x = 3$ ,  $\frac{dy}{dx} = \frac{7}{8}$   
 $\frac{dy}{dt} = \frac{dy}{dx} \times \frac{dx}{dt} = 7$  units/minute.

59. (i) Subst.  $x = p$  into  $y = 2x^2$  gives  $Q(p, 2p^2)$   
 Area,  $A = \frac{1}{2}(p+2)(2p^2) = p^3 + 2p^2$

(ii)  $\frac{dA}{dp} = 3p^2 + 4p$ , at  $p = 2$ ,  $\frac{dA}{dp} = 20$   
 $\frac{dA}{dt} = \frac{dA}{dp} \times \frac{dp}{dt} = 0.4$  units per second.

60. (i)  $\frac{dy}{dx} = 3x^2 + 2px$   
 At  $x = 0$ ,  $\frac{dy}{dx} = 0$ , and  $y = 0^3 + p(0)^2 = 0$   
 Hence, origin is a stationary point.

Also,  $\frac{dy}{dx} = 3x^2 + 2px = 0 \Rightarrow x = -\frac{2p}{3}$   
 $\therefore y = \left(-\frac{2p}{3}\right)^3 + p\left(-\frac{2p}{3}\right)^2 = \frac{4p^3}{27}$   
 $\therefore$  Other stationary point is,  $\left(-\frac{2p}{3}, \frac{4p^3}{27}\right)$

(ii) At  $x = 0$ ,  $\frac{d^2y}{dx^2} = 2p$ ,  $\therefore (0, 0)$  is Minimum.

At  $x = -\frac{2p}{3}$ ,  $\frac{d^2y}{dx^2} = -2p$ ,  
 $\therefore \left(-\frac{2p}{3}, \frac{4p^3}{27}\right)$  is Maximum.

(iii)  $\frac{dy}{dx} = 3x^2 + 2px + p$   
 The curve has no stationary point,  
 $\Rightarrow b^2 - 4ac < 0$   
 $\Rightarrow (2p)^2 - 4(3)(p) < 0 \Rightarrow 0 < p < 3$

61.  $u = 2x(y-x) \dots\dots(1)$ ,  $x+3y=12 \dots\dots(2)$

Solving simultaneously gives,  $u = 8x - \frac{8}{3}x^2$

$\frac{du}{dx} = 8 - \frac{16}{3}x = 0 \Rightarrow x = \frac{3}{2}$   
 $\therefore$  stationary value of  $u = 8\left(\frac{3}{2}\right) - \frac{8}{3}\left(\frac{3}{2}\right)^2 = 6$

62. (i)  $f'(x) = -\frac{1}{(x+1)^2} - \frac{2}{(x+1)^3}$

(ii)  $f'(x) < 0$ ,  $\therefore f$  is a decreasing function.

(iii)  $g'(x) = -\frac{1}{(x+1)^2} - \frac{2}{(x+1)^3} = 0 \Rightarrow x = -3$   
 $\Rightarrow g(-3) = \frac{1}{-3+1} + \frac{1}{(-3+1)^2} = -\frac{1}{4}$   
 $\therefore$  stationary point is  $\left(-3, -\frac{1}{4}\right)$

63.  $\int f'(x) dx = \int (3x^2 - 7) dx$   
 $\Rightarrow f(x) = x^3 - 7x + C$   
 Subst. (3, 5) gives,  $C = -1$   
 $\therefore f(x) = x^3 - 7x - 1$

64. (i)  $\frac{dy}{dx} = -\frac{8}{x^2} + 2$ ,  $\frac{d^2y}{dx^2} = \frac{16}{x^3}$

(ii)  $\frac{dy}{dx} = -\frac{8}{x^2} + 2 = 0 \Rightarrow x = \pm 2$

At  $x = 2$ ,  $y = \frac{8}{2} + 2(2) = 8$

At  $x = -2$ ,  $y = \frac{8}{-2} + 2(-2) = -8$

$\therefore$  stationary points are (2, 8) and (-2, -8)

At  $x = 2$ ,  $\frac{d^2y}{dx^2} = 2$ ,  $\therefore (2, 8)$  is Minimum.

At  $x = -2$ ,  $\frac{d^2y}{dx^2} = -2$ ,  $\therefore (-2, -8)$  is Max.

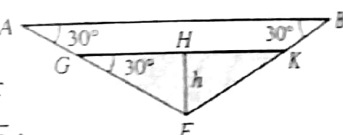
65. (i) In  $\triangle GHE$ ,   
 $\tan 30^\circ = \frac{h}{GH}$   
 $\Rightarrow GH = \sqrt{3}h$   
 $V = \text{area of } \triangle GEK \times \text{length of tank}$   
 $= \frac{1}{2}(2\sqrt{3}h)(h) \times 40 = (40\sqrt{3})h^2$

(ii)  $\frac{dV}{dh} = (80\sqrt{3})h$ , when  $h = 5$ ,  $\frac{dV}{dh} = 400\sqrt{3}$   
 $\frac{dV}{dt} = \frac{dV}{dh} \times \frac{dh}{dt} \Rightarrow \frac{dh}{dt} = \frac{1}{2\sqrt{3}} \text{ cms}^{-1}$

66. (i)  $f'(x) = \int 12x^{-3} dx = -\frac{6}{x^2} + K$

$f'(x) = 0$  at  $x = 2$ ,  $\Rightarrow K = \frac{3}{2}$

$\therefore f'(x) = -\frac{6}{x^2} + \frac{3}{2}$

now,  $f(x) = \int \left(-\frac{6}{x^2} + \frac{3}{2}\right) dx = \frac{6}{x} + \frac{3}{2}x + C$

Subst. (2, 10) gives,  $C = 4$

$\therefore f(x) = \frac{6}{x} + \frac{3}{2}x + 4$

(ii)  $f'(x) = -\frac{6}{x^2} + \frac{3}{2} = 0 \Rightarrow x = \pm 2$

when  $x = -2$ ,  $f(x) = \frac{6}{-2} + \frac{3}{2}(-2) + 4 = -2$

$\therefore$  Other stationary point is  $(-2, -2)$

(iii)  $f''(2) = \frac{3}{2}$ ,  $\therefore (2, 10)$  is minimum

$f''(-2) = -\frac{3}{2}$ ,  $\therefore (-2, -2)$  is maximum.

67. (i) At  $A(4, 6)$ ,  $\frac{dy}{dx} = 1 + 2(4)^{-\frac{1}{2}} = 2$

$\frac{dy}{dt} = \frac{dy}{dx} \times \frac{dx}{dt} = 2 \times 3 = 6$  units/minute.

(ii)  $\int dy = \int (1 + 2x^{-\frac{1}{2}}) dx \Rightarrow y = x + 4x^{\frac{1}{2}} + K$

Subst.  $(4, 6)$  gives,  $K = -6$

$\therefore$  equation of curve:  $y = x + 4x^{\frac{1}{2}} - 6$

(iii) Equation of  $AB$ :  $y = 2x - 2$

Subst.  $y = 0$  gives point  $B(1, 0)$

Equation of  $AC$ :  $2y + x = 16$

Subst.  $y = 0$  gives point  $C(16, 0)$

Area of  $\triangle ABC = \frac{1}{2} \times 15 \times 6 = 45$  units<sup>2</sup>

68. (i) At  $x = 0$ ,  $\frac{dy}{dx} = 2 - 8(0+4)^{-\frac{1}{2}} = -2$

$\frac{dy}{dt} = \frac{dy}{dx} \times \frac{dx}{dt} = -2 \times 0.3 = -0.6$  units/s

(ii)  $\int dy = \int \left( 2 - 8(3x+4)^{-\frac{1}{2}} \right) dx$

$\Rightarrow y = 2x - \frac{16}{3}(3x+4)^{\frac{1}{2}} + K$

Subst.  $(0, \frac{4}{3})$  gives,  $K = 12$

$\therefore$  equation:  $y = 2x - \frac{16}{3}(3x+4)^{\frac{1}{2}} + 12$

69. (i) Total perimeter of fencing = 480 m

$\Rightarrow 12x + 10y = 480 \Rightarrow y = \frac{240 - 6x}{5}$

Area,  $A = 8xy$

$= 8x \left( \frac{240 - 6x}{5} \right) = 384x - 9.6x^2$

(ii)  $\frac{dA}{dx} = 384 - 19.2x = 0 \Rightarrow x = 20$

$\Rightarrow y = \frac{240 - 6(20)}{5} = 24$

$\therefore$  Dimensions are 20m by 24m.

70. (i)  $\frac{dy}{dx} = -\frac{8}{x^2} + 2$ ,  $\frac{d^2y}{dx^2} = \frac{16}{x^3}$

$$\int y^2 dx = \int \left( \frac{8}{x} + 2x \right)^2 dx$$

$$= \int \left( \frac{64}{x^2} + 32 + 4x^2 \right) dx$$

$$= -\frac{64}{x} + 32x + \frac{4}{3}x^3 + K$$

(ii)  $\frac{dy}{dx} = -\frac{8}{x^2} + 2 = 0 \Rightarrow x = \pm 2$

$\Rightarrow x = 2$  (since  $x > 0$ )

$\therefore y = \frac{8}{2} + 2(2) = 8$ ,  $\therefore$  point  $M$  is  $(2, 8)$

For  $x < 0$ ,  $x = -2$ ,  $\Rightarrow y = \frac{8}{-2} + 2(-2) = -8$

$\therefore$  stationary point for  $x < 0$  is  $(-2, -8)$

$\frac{d^2y}{dx^2} = -2$  ( $< 0$ ),  $\therefore (-2, -8)$  is maximum.

(iii) Volume =  $\pi \int_1^2 y^2 dx$

$= \pi \int_1^2 \left( \frac{8}{x} + 2x \right)^2 dx$

$= \pi \left[ -\frac{64}{x} + 32x + \frac{4}{3}x^3 \right]_1^2 = \frac{220}{3}\pi$

71.  $\frac{dy}{dx} = 8 - 2(2x-1)^{-2} = 0 \Rightarrow (2x-1) = \pm \frac{1}{2}$

$\therefore x = \frac{3}{4}$ , or  $x = \frac{1}{4}$

At  $x = \frac{3}{4}$ ,  $\frac{d^2y}{dx^2} = 64$ ,  $\therefore$  Minimum

At  $x = \frac{1}{4}$ ,  $\frac{d^2y}{dx^2} = -64$ ,  $\therefore$  Maximum

72.  $\frac{dy}{dx} = 2x - 5x^{\frac{1}{2}} + 5$

Given,  $\frac{dx}{dt} = \frac{1}{2} \left( \frac{dy}{dt} \right) \Rightarrow \frac{dy}{dx} = 2$

$\therefore 2x - 5x^{\frac{1}{2}} + 5 = 2 \Rightarrow 2x - 5x^{\frac{1}{2}} + 3 = 0$

$\Rightarrow (x^{\frac{1}{2}} - 1)(2x^{\frac{1}{2}} - 3) \Rightarrow x = 1, x = \frac{9}{4}$

73. (i)  $3x^{\frac{1}{2}} - 2x^{-\frac{1}{2}} = -1 \Rightarrow 3x + x^{\frac{1}{2}} - 2 = 0$

$\Rightarrow (x^{\frac{1}{2}} + 1)(3x^{\frac{1}{2}} - 2) = 0 \Rightarrow x = \frac{4}{9}$

(ii)  $f(x) = \int (3x^{\frac{1}{2}} - 2x^{-\frac{1}{2}}) dx = 2x^{\frac{3}{2}} - 4x^{\frac{1}{2}} + C$

Subst. (4, 10) gives,  $C = 2$

$\therefore f(x) = 2x^{\frac{3}{2}} - 4x^{\frac{1}{2}} + 2$

At  $x = \frac{4}{9}$ ,  $f(\frac{4}{9}) = 2(\frac{4}{9})^{\frac{3}{2}} - 4(\frac{4}{9})^{\frac{1}{2}} + 2 = -\frac{2}{27}$

$\therefore$  y-coordinate of A =  $-\frac{2}{27}$

74. (i)  $\frac{dy}{dx} = -\frac{1}{(x-1)^2} + \frac{9}{(x-5)^2}$

At  $x = 3$ ,  $\frac{dy}{dx} = 2$ ,  $\therefore$  grad. of normal =  $-\frac{1}{2}$

Equation of normal:  $2y + x = 13$

Subst.  $y = 0$ , into this eq. gives,  $x = 13$

(ii)  $\frac{dy}{dx} = -\frac{1}{(x-1)^2} + \frac{9}{(x-5)^2} = 0$

$\Rightarrow x^2 - x - 2 = 0 \Rightarrow x = 2, x = -1$

$\frac{d^2y}{dx^2} = \frac{2}{(x-1)^3} - \frac{18}{(x-5)^3}$

At  $x = 2$ ,  $\frac{d^2y}{dx^2} = \frac{8}{3}$ ,  $\therefore$  Minimum

At  $x = -1$ ,  $\frac{d^2y}{dx^2} = -\frac{1}{6}$ ,  $\therefore$  Maximum

75. (i)  $\frac{dy}{dx} = -\frac{6}{(2x-1)^2}$

(ii) Since the gradient is always negative, thus the curve has no stationary points.

(iii) Subst.  $x = 2$ , into eq. of curve gives,  $P(2, 3)$

at  $x = 2$ ,  $\frac{dy}{dx} = -\frac{2}{3}$ ,  $\Rightarrow$  grad. of normal =  $\frac{3}{2}$

eq. of normal:  $y - 3 = \frac{3}{2}(x - 2) \Rightarrow y = \frac{3}{2}x$

Subst.  $x = 0$ , gives  $y = 0$ .

$\therefore$  the normal passes through the origin.

(iv) At  $x = 2$ ,  $\frac{dy}{dx} = -\frac{2}{3}$

$\frac{dy}{dt} = \frac{dy}{dx} \times \frac{dx}{dt} = -\frac{2}{3} \times -0.06 = 0.04$  units/s

76.  $f'(x) = 3x^2 - 6x - 9 > 0$

$\Rightarrow x^2 - 2x - 3 > 0 \Rightarrow (x+1)(x-3) > 0$

$\Rightarrow x < -1, x > 3$

$\therefore$  least possible value of  $n = 3$ .

77. (i) When  $x = a^2$ ,  $\frac{dy}{dx} = \frac{3}{a^2}$

Equation:  $y - 3 = \frac{3}{a^2}(x - a^2) \Rightarrow y = \frac{3}{a^2}x$

(ii)  $\int dy = \int \left( \frac{2}{a}x^{-\frac{1}{2}} + ax^{-\frac{3}{2}} \right) dx$

$\Rightarrow y = \frac{4}{a}x^{\frac{1}{2}} - 2ax^{-\frac{1}{2}} + K$

Subst.  $(a^2, 3)$  gives,  $K = 1$

$\therefore$  equation:  $y = \frac{4}{a}x^{\frac{1}{2}} - 2ax^{-\frac{1}{2}} + 1$

(iii) Subst. (16, 8) into equation of curve, gives,

$a^2 + 14a - 32 = 0 \Rightarrow (a+16)(a-2) = 0$

$\Rightarrow a = 2$

$\therefore A(4, 3), B(16, 8), |AB| = 13$  units.

58. A point  $P$  travels along the curve  $y = (7x^2 + 1)^{\frac{1}{3}}$  in such a way that the  $x$ -coordinate of  $P$  at time  $t$  minutes is increasing at a constant rate of 8 units per minute. Find the rate of increase of the  $y$ -coordinate of  $P$  at the instant when  $P$  is at the point  $(3, 4)$ .

[N14/P13/Q10(b)]

59. The diagram shows the curve  $y = 2x^2$  and the points  $X(-2, 0)$  and  $P(p, 0)$ . The point  $Q$  lies on the curve and  $PQ$  is parallel to the  $y$ -axis.

- (i) Express the area,  $A$ , of triangle  $XPQ$  in terms of  $p$ .

The point  $P$  moves along the  $x$ -axis at a constant rate of 0.02 units per second and  $Q$  moves along the curve so that  $PQ$  remains parallel to the  $y$ -axis.

- (ii) Find the rate at which  $A$  is increasing when  $p = 2$ .

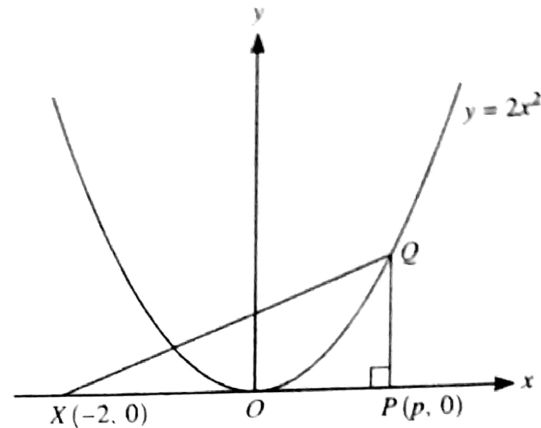

[J15/P11/Q2]

60. The equation of a curve is  $y = x^3 + px^2$ , where  $p$  is a positive constant.

- (i) Show that the origin is a stationary point on the curve and find the coordinates of the other stationary point in terms of  $p$ .  
 (ii) Find the nature of each of the stationary points.

Another curve has equation  $y = x^3 + px^2 + px$ .

- (iii) Find the set of values of  $p$  for which this curve has no stationary points.

[J15/P11/Q9]

61. Variables  $u$ ,  $x$  and  $y$  are such that  $u = 2x(y - x)$  and  $x + 3y = 12$ . Express  $u$  in terms of  $x$  and hence find the stationary value of  $u$ .

[J15/P12/Q4]

62. The function  $f$  is defined by  $f(x) = \frac{1}{x+1} + \frac{1}{(x+1)^2}$  for  $x > -1$ .

- (i) Find  $f'(x)$ .  
 (ii) State, with a reason, whether  $f$  is an increasing function, a decreasing function or neither.

The function  $g$  is defined by  $g(x) = \frac{1}{x+1} + \frac{1}{(x+1)^2}$  for  $x < -1$ .

- (iii) Find the coordinates of the stationary point on the curve  $y = g(x)$ .

[J15/P13/Q8]

63. The function  $f$  is such that  $f'(x) = 3x^2 - 7$  and  $f(3) = 5$ . Find  $f(x)$ .

[N15/P11/Q2]



64. A curve has equation  $y = \frac{8}{x} + 2x$ .

(i) Find  $\frac{dy}{dx}$  and  $\frac{d^2y}{dx^2}$ .

(ii) Find the coordinates of the stationary points and state, with a reason, the nature of each stationary point. [N15/P11/Q5]

65.

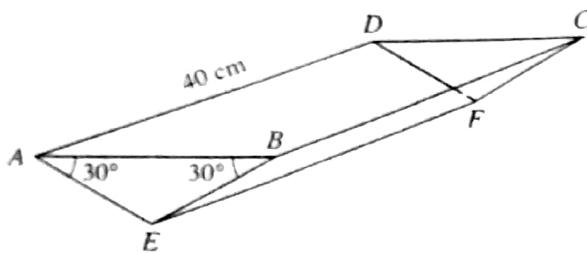

Fig. 1

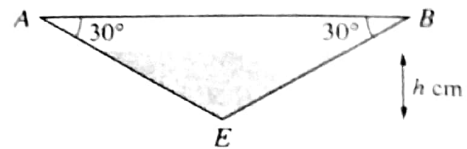

Fig. 2

Fig. 1 shows an open tank in the shape of a triangular prism. The vertical ends  $ABE$  and  $DCF$  are identical isosceles triangles. Angle  $ABE = \text{angle } BAE = 30^\circ$ . The length of  $AD$  is 40 cm. The tank is fixed in position with the open top  $ABCD$  horizontal. Water is poured into the tank at a constant rate of  $200 \text{ cm}^3 \text{ s}^{-1}$ . The depth of water,  $t$  seconds after filling starts, is  $h$  cm (see Fig. 2).

(i) Show that, when the depth of water in the tank is  $h$  cm, the volume,  $V \text{ cm}^3$ , of water in the tank is given by  $V = (40\sqrt{3})h^2$ .

(ii) Find the rate at which  $h$  is increasing when  $h = 5$ . [N15/P12/Q3]

66. The curve  $y = f(x)$  has a stationary point at  $(2, 10)$  and it is given that  $f''(x) = \frac{12}{x^3}$ .

(i) Find  $f(x)$ .

(ii) Find the coordinates of the other stationary point.

(iii) Find the nature of each of the stationary points. [N15/P12/Q9]

67. A curve passes through the point  $A(4, 6)$  and is such that  $\frac{dy}{dx} = 1 + 2x^{-\frac{1}{2}}$ . A point  $P$  is moving along the curve in such a way that the  $x$ -coordinate of  $P$  is increasing at a constant rate of 3 units per minute.

(i) Find the rate at which the  $y$ -coordinate of  $P$  is increasing when  $P$  is at  $A$ .

(ii) Find the equation of the curve.

(iii) The tangent to the curve at  $A$  crosses the  $x$ -axis at  $B$  and the normal to the curve at  $A$  crosses the  $x$ -axis at  $C$ . Find the area of triangle  $ABC$ . [N15/P13/Q9]

# TOPIC 10

## Integration

7. A curve is such that  $\frac{dy}{dx} = \frac{4}{\sqrt{6-2x}}$ , and  $P(1, 8)$  is a point on the curve.

- (i) The normal to the curve at the point  $P$  meets the coordinate axes at  $Q$  and at  $R$ . Find the coordinates of the mid-point of  $QR$ .
- (ii) Find the equation of the curve.

[J06/P12/Q9]

8. The diagram shows the curve  $y = x(x-1)(x-2)$ , which crosses the  $x$ -axis at the points  $O(0, 0)$ ,  $A(1, 0)$  and  $B(2, 0)$ .

- (i) The tangents to the curve at the points  $A$  and  $B$  meet at the point  $C$ . Find the  $x$ -coordinate of  $C$ .
- (ii) Show by integration that the area of the shaded region  $R_1$  is the same as the area of the shaded region  $R_2$ .

[N06/P12/Q7]

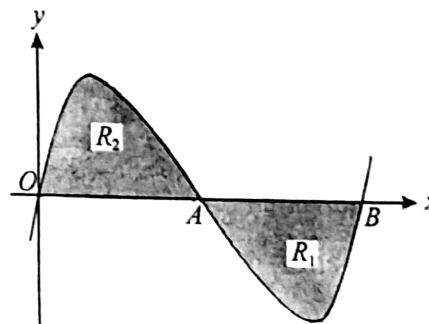

9. The diagram shows the curve  $y = 3x^{\frac{1}{4}}$ . The shaded region is bounded by the curve, the  $x$ -axis and the lines  $x = 1$  and  $x = 4$ . Find the volume of the solid obtained when this shaded region is rotated completely about the  $x$ -axis, giving your answer in terms of  $\pi$ .

[J07/P12/Q2]

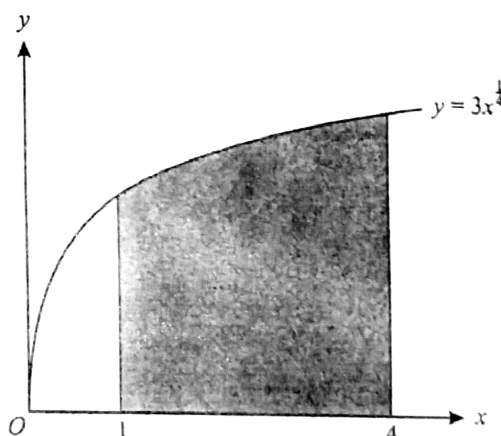

10. Find the area of the region enclosed by the curve  $y = 2\sqrt{x}$ , the  $x$ -axis and the lines  $x = 1$  and  $x = 4$ .

[N07/P12/Q2]

11. A curve is such that  $\frac{dy}{dx} = 4 - x$  and the point  $P(2, 9)$  lies on the curve. The normal to the curve at  $P$  meets the curve again at  $Q$ . Find

- (i) the equation of the curve,
- (ii) the equation of the normal to the curve at  $P$ ,
- (iii) the coordinates of  $Q$ .

[N07/P12/Q9]

12. The diagram shows a curve for which

$\frac{dy}{dx} = -\frac{k}{x^3}$ , where  $k$  is a constant. The curve passes through the points  $(1, 18)$  and  $(4, 3)$ .

(i) Show, by integration, that the equation of

the curve is  $y = \frac{16}{x^2} + 2$ .

The point  $P$  lies on the curve and has  $x$ -coordinate 1.6.

(ii) Find the area of the shaded region.

[J08/P12/Q9]

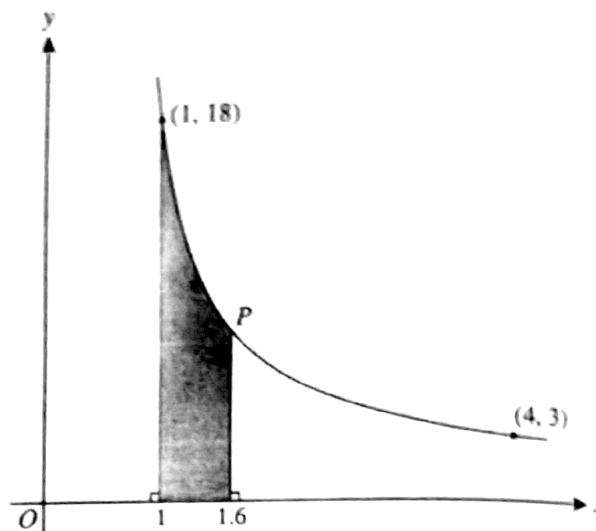

13. The diagram shows the curve  $y = \sqrt{3x+1}$  and the points  $P(0, 1)$  and  $Q(1, 2)$  on the curve. The shaded region is bounded by the curve, the  $y$ -axis and the line  $y = 2$ .

(i) Find the area of the shaded region.

(ii) Find the volume obtained when the shaded region is rotated through  $360^\circ$  about the  $x$ -axis.

Tangents are drawn to the curve at the points  $P$  and  $Q$ .

(iii) Find the acute angle, in degrees correct to 1 decimal place, between the two tangents.

[N08/P12/Q9]

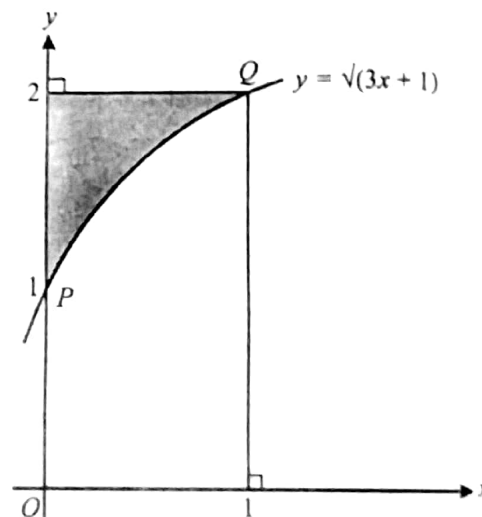

14. The diagram shows part of the curve  $y = \frac{6}{3x-2}$ .

(i) Find the gradient of the curve at the point where  $x = 2$ .

(ii) Find the volume obtained when the shaded region is rotated through  $360^\circ$  about the  $x$ -axis, giving your answer in terms of  $\pi$ .

[J09/P12/Q9]

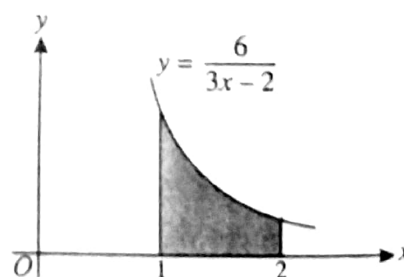

15. The equation of a curve is  $y = x^4 + 4x + 9$ .

(i) Find the coordinates of the stationary point on the curve and determine its nature.

(ii) Find the area of the region enclosed by the curve, the  $x$ -axis and the lines  $x = 0$  and  $x = 1$ .

[N09/P11/Q4]

16. A curve is such that  $\frac{dy}{dx} = k - 2x$ , where  $k$  is a constant.
- (i) Given that the tangents to the curve at the points where  $x = 2$  and  $x = 3$  are perpendicular, find the value of  $k$ .
- (ii) Given also that the curve passes through the point  $(4, 9)$ , find the equation of the curve.
- [N09/P11/Q6]

17. The equation of a curve is such that  $\frac{dy}{dx} = \frac{3}{\sqrt{x}} - x$ . Given that the curve passes through the point  $(4, 6)$ , find the equation of the curve.
- [N09/P12/Q1]

18. The function  $f$  is such that  $f(x) = \frac{3}{2x+5}$  for  $x \in \mathbb{R}$ ,  $x \neq -2.5$ .
- A curve has the equation  $y = f(x)$ . Find the volume obtained when the region bounded by the curve, the coordinate axes and the line  $x = 2$  is rotated through  $360^\circ$  about the  $x$ -axis.
- [N09/P12/Q8 (iii)]

19. The diagram shows the curve  $y = 6x - x^2$  and the line  $y = 5$ . Find the area of the shaded region.

[J10/P11/Q4]

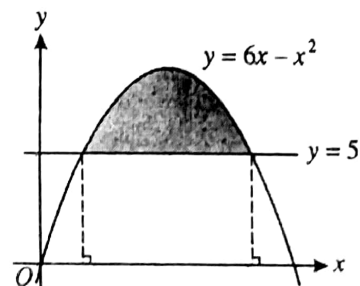

20. A curve is such that  $\frac{dy}{dx} = 3x^{\frac{1}{2}} - 6$  and the point  $(9, 2)$  lies on the curve.
- (i) Find the equation of the curve.
- (ii) Find the  $x$ -coordinate of the stationary point on the curve and determine the nature of the stationary point.
- [J10/P11/Q6]

21. The diagram shows part of the curve  $y = \frac{a}{x}$ , where  $a$  is a positive constant. Given that the volume obtained when the shaded region is rotated through  $360^\circ$  about the  $x$ -axis is  $24\pi$ , find the value of  $a$ .

[J10/P12/Q2]

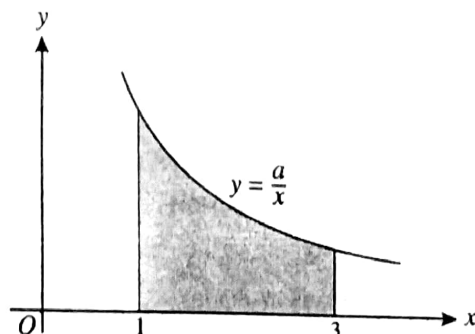

22. The diagram shows the curve  $y = (x-2)^2$  and the line  $y + 2x = 7$ , which intersect at points  $A$  and  $B$ . Find the area of the shaded region.  
[J10/P12/Q9]

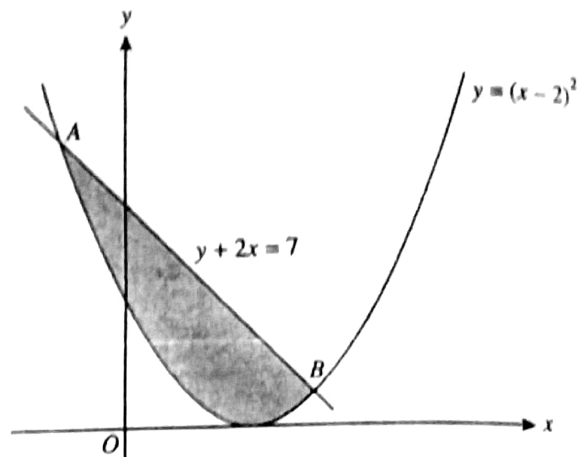

23. The equation of a curve is such that  $\frac{dy}{dx} = \frac{6}{\sqrt{3x-2}}$ . Given that the curve passes through the point  $P(2, 11)$ , find  
(i) the equation of the normal to the curve at  $P$ ,  
(ii) the equation of the curve.  
[J10/P13/Q5]

24. The diagram shows part of the curve  $y = x + \frac{4}{x}$  which has a minimum point at  $M$ . The line  $y = 5$  intersects the curve at the points  $A$  and  $B$ .  
(i) Find the coordinates of  $A$ ,  $B$  and  $M$ .  
(ii) Find the volume obtained when the shaded region is rotated through  $360^\circ$  about the  $x$ -axis.  
[J10/P13/Q9]

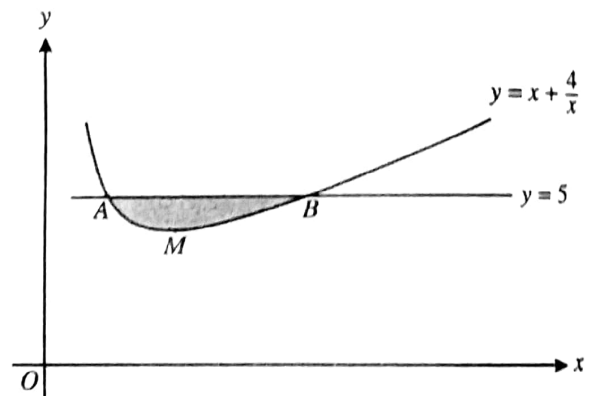

25. Find  $\int \left(x + \frac{1}{x}\right)^2 dx$ .  
[N10/P11/Q1]

26. The equation of a curve is  $y = \frac{9}{2-x}$ .  
(i) Find an expression for  $\frac{dy}{dx}$  and determine, with a reason, whether the curve has any stationary points.  
(ii) Find the volume obtained when the region bounded by the curve, the coordinate axes and the line  $x = 1$  is rotated through  $360^\circ$  about the  $x$ -axis.  
(iii) Find the set of values of  $k$  for which the line  $y = x + k$  intersects the curve at two distinct points.  
[N10/P11/Q11]



27. The diagram shows part of the curve

$$y = \frac{1}{(3x+1)^4}$$

The curve cuts the  $y$ -axis at  $A$

and the line  $x = 5$  at  $B$ .

(i) Show that the equation of the line  $AB$  is  $y = -\frac{1}{10}x + 1$ .

(ii) Find the volume obtained when the shaded region is rotated through  $360^\circ$  about the  $x$ -axis.

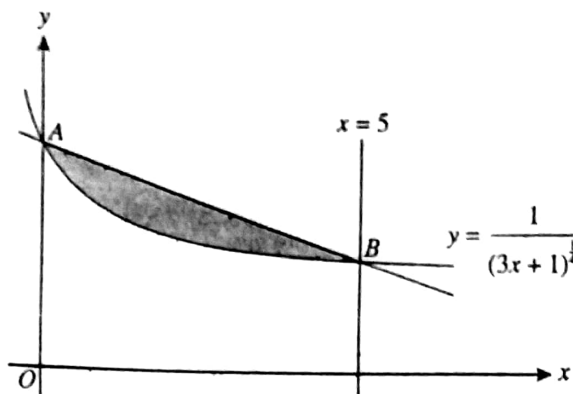

[N10/P12/Q11]

28. A curve has equation  $y = f(x)$ . It is given that  $f'(x) = 3x^2 + 2x - 5$ .

(i) Find the set of values of  $x$  for which  $f$  is an increasing function.

(ii) Given that the curve passes through  $(1, 3)$ , find  $f(x)$ .

[N10/P13/Q6]

29. The diagram shows parts of the curves

$$y = 9 - x^3 \text{ and } y = \frac{8}{x^3}$$

and their points of intersection  $P$  and  $Q$ . The  $x$ -coordinates of  $P$  and  $Q$  are  $a$  and  $b$  respectively.

(i) Show that  $x = a$  and  $x = b$  are roots of the equation  $x^6 - 9x^3 + 8 = 0$ . Solve this equation and hence state the value of  $a$  and the value of  $b$ .

(ii) Find the area of the shaded region between the two curves.

(iii) The tangents to the two curves at  $x = c$  (where  $a < c < b$ ) are parallel to each other. Find the value of  $c$ .

[N10/P13/Q11]

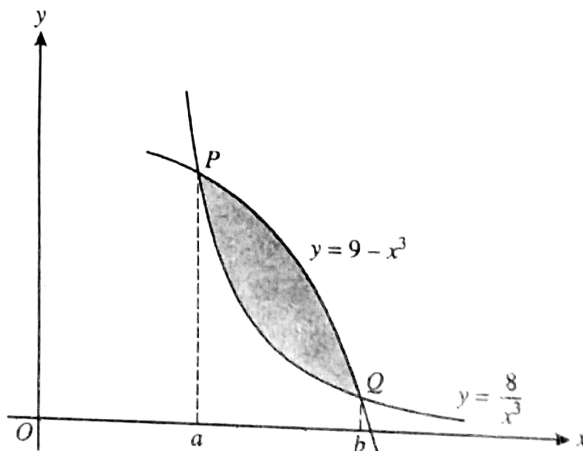

30. (i) Sketch the curve  $y = (x - 2)^2$ .

(ii) The region enclosed by the curve, the  $x$ -axis and the  $y$ -axis is rotated through  $360^\circ$  about the  $x$ -axis. Find the volume obtained, giving your answer in terms of  $\pi$ .

[J11/P11/Q3]

31. A curve is such that  $\frac{dy}{dx} = \frac{3}{(1+2x)^2}$  and the point  $(1, \frac{1}{2})$  lies on the curve.

(i) Find the equation of the curve.

(ii) Find the set of values of  $x$  for which the gradient of the curve is less than  $\frac{1}{3}$ .

[J11/P11/Q7]

32. Find  $\int \left( x^3 + \frac{1}{x^3} \right) dx$ .

[J11/P12/Q1]

33. The diagram shows part of the curve  $y = 4\sqrt{x} - x$ . The curve has a maximum point at  $M$  and meets the  $x$ -axis at  $O$  and  $A$ .

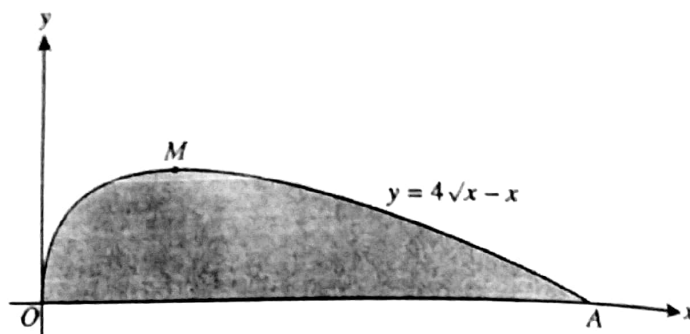

- (i) Find the coordinates of  $A$  and  $M$ .
- (ii) Find the volume obtained when the shaded region is rotated through  $360^\circ$  about the  $x$ -axis, giving your answer in terms of  $\pi$ .

[J11/P12/Q11]

34. (a) Differentiate  $\frac{2x^3 + 5}{x}$  with respect to  $x$ .

(b) Find  $\int (3x - 2)^5 dx$  and hence find the value of  $\int_0^1 (3x - 2)^5 dx$ .

[J11/P13/Q4]

35. A curve is such that  $\frac{dy}{dx} = \frac{2}{\sqrt{x}} - 1$  and  $P(9, 5)$  is a point on the curve.

- (i) Find the equation of the curve.
- (ii) Find the coordinates of the stationary point on the curve.
- (iii) Find an expression for  $\frac{d^2y}{dx^2}$  and determine the nature of the stationary point.
- (iv) The normal to the curve at  $P$  makes an angle of  $\tan^{-1} k$  with the positive  $x$ -axis. Find the value of  $k$ .

[J11/P13/Q9]

36. A function  $f$  is defined for  $x \in \mathbb{R}$  and is such that  $f'(x) = 2x - 6$ . The range of the function is given by  $f(x) \geq -4$ .

- (i) State the value of  $x$  for which  $f(x)$  has a stationary value.
- (ii) Find an expression for  $f(x)$  in terms of  $x$ .

[N11/P11/Q4]

37. The equation of a curve is  $y = \sqrt{8x - x^2}$ . Find

- (i) an expression for  $\frac{dy}{dx}$ , and the coordinates of the stationary point on the curve,
- (ii) the volume obtained when the region bounded by the curve and the  $x$ -axis is rotated through  $360^\circ$  about the  $x$ -axis.

[N11/P12/Q8]

L

38.

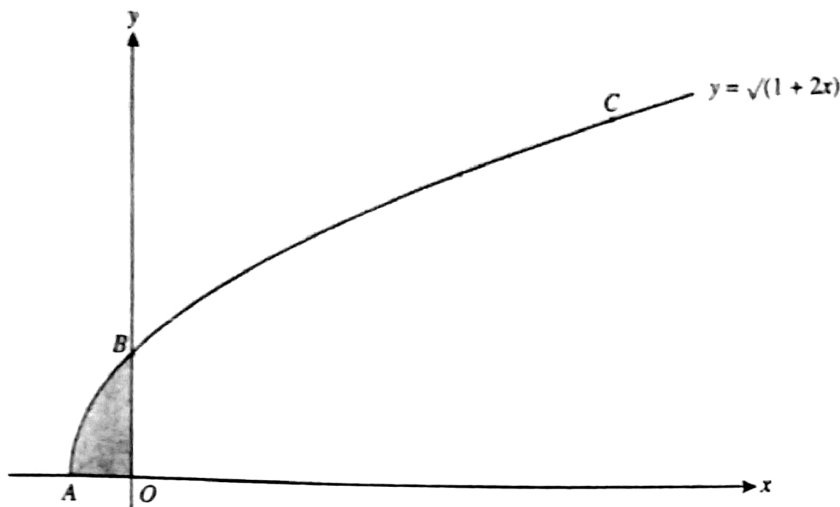

The diagram shows the curve  $y = \sqrt{1 + 2x}$  meeting the  $x$ -axis at  $A$  and the  $y$ -axis at  $B$ .  
 The  $y$ -coordinate of the point  $C$  on the curve is 3.

- (i) Find the coordinates of  $B$  and  $C$ .
- (ii) Find the equation of the normal to the curve at  $C$ .
- (iii) Find the volume obtained when the shaded region is rotated through  $360^\circ$  about the  $y$ -axis

[N11/P11/Q10]

39. The diagram shows the line  $y = x + 1$  and the curve  $y = \sqrt{x + 1}$ , meeting at  $(-1, 0)$  and  $(0, 1)$ .

- (i) Find the area of the shaded region.
- (ii) Find the volume obtained when the shaded region is rotated through  $360^\circ$  about the  $y$ -axis.

[N11/P13/Q10]

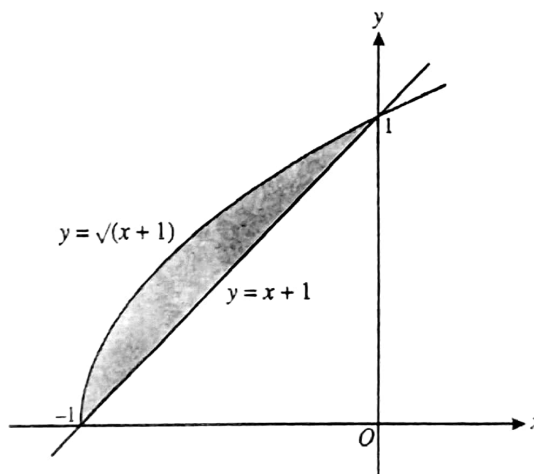

40. The diagram shows the line  $y = 1$  and part of the curve  $y = \frac{2}{\sqrt{x + 1}}$ .

- (i) Show that the equation  $y = \frac{2}{\sqrt{x + 1}}$  can be written in the form  $x = \frac{4}{y^2} - 1$ .

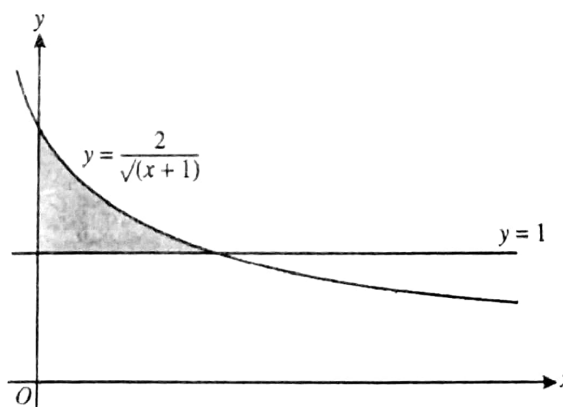

(ii) Find  $\int \left( \frac{4}{y^2} - 1 \right) dy$ . Hence find the area of the shaded region.

(iii) The shaded region is rotated through  $360^\circ$  about the  $y$ -axis. Find the exact value of the volume of revolution obtained. [J12/P11/Q11]

41. The diagram shows the region enclosed by the curve

$y = \frac{6}{2x-3}$ , the  $x$ -axis and the lines  $x = 2$  and  $x = 3$ . Find, in terms of  $\pi$ , the volume obtained when this region is rotated through  $360^\circ$  about the  $x$ -axis.

[J12/P12/Q1]

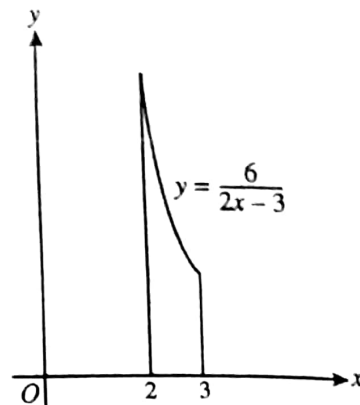

42. The diagram shows part of the curve  $y = -x^2 + 8x - 10$  which passes through the points  $A$  and  $B$ . The curve has a maximum point at  $A$  and the gradient of the line  $BA$  is 2.

(i) Find the coordinates of  $A$  and  $B$ .

(ii) Find  $\int y \, dx$  and hence evaluate the area of the shaded region.

[J12/P12/Q9]

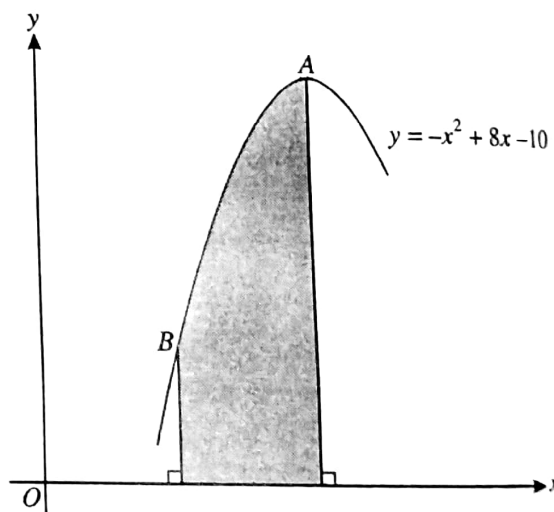

43. The diagram shows part of the curve

$x = \frac{8}{y^2} - 2$ , crossing the  $y$ -axis at the

point  $A$ . The point  $B(6, 1)$  lies on the curve. The shaded region is bounded by the curve, the  $y$ -axis and the line  $y = 1$ . Find the exact volume obtained when this shaded region is rotated through  $360^\circ$  about the  $y$ -axis.

[J12/P13/Q5]

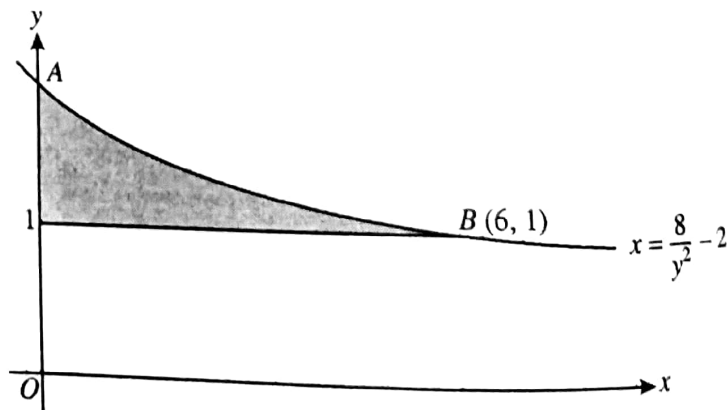



44. A curve is such that  $\frac{d^2y}{dx^2} = -4x$ . The curve has a maximum point at (2, 12).

(i) Find the equation of the curve.

A point  $P$  moves along the curve in such a way that the  $x$ -coordinate is increasing at 0.05 units per second.

(ii) Find the rate at which the  $y$ -coordinate is changing when  $x = 3$ , stating whether the  $y$ -coordinate is increasing or decreasing.

[J12/P13/Q9]

45. A curve is such that  $\frac{dy}{dx} = -\frac{8}{x^3} - 1$  and the point (2, 4) lies on the curve. Find the equation of the curve.

[N12/P11/Q2]

46. The diagram shows the curve  $y^2 = 2x - 1$  and the straight line  $3y = 2x - 1$ . The curve and straight line intersect at  $x = \frac{1}{2}$  and  $x = a$ , where  $a$  is a constant.

(i) Show that  $a = 5$ .

(ii) Find, showing all necessary working, the area of the shaded region.

[N12/P11/Q8]

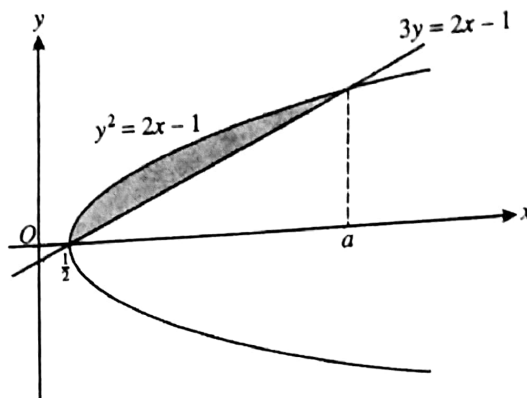

47. The diagram shows part of the curve  $y = \frac{9}{2x+3}$ , crossing the  $y$ -axis at the point  $B(0, 3)$ . The point  $A$  on the curve has coordinates (3, 1) and the tangent to the curve at  $A$  crosses the  $y$ -axis at  $C$ .

(i) Find the equation of the tangent to the curve at  $A$ .

(ii) Determine, showing all necessary working, whether  $C$  is nearer to  $B$  or to  $O$ .

(iii) Find, showing all necessary working, the exact volume obtained when the shaded region is rotated through  $360^\circ$  about the  $x$ -axis.

[N12/P12/Q9]

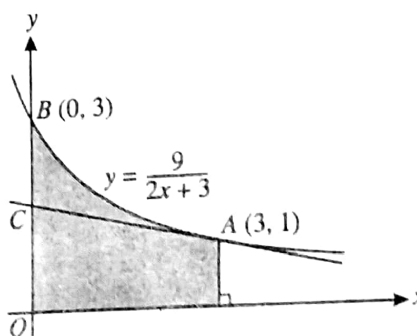

48. The diagram shows the curve with equation  $y = x(x-2)^2$ . The minimum point on the curve has coordinates  $(a, 0)$  and the  $x$ -coordinate of the maximum point is  $b$ , where  $a$  and  $b$  are constants.

(i) State the value of  $a$ .

(ii) Find the value of  $b$ .

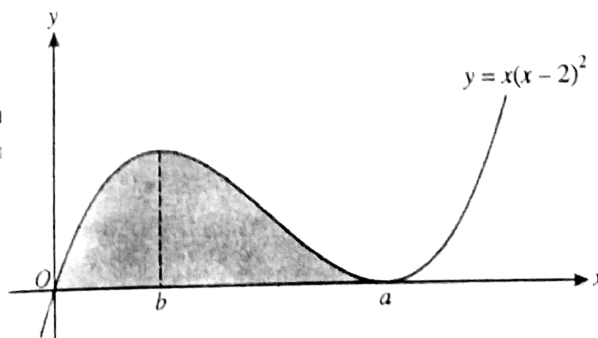



(iii) Find the area of the shaded region.

(iv) The gradient,  $\frac{dy}{dx}$ , of the curve has a minimum value  $m$ . Find the value of  $m$ . [N12/P13/Q11]

49. The diagram shows part of the curve  $y = (x - 2)^4$  and the point  $A(1, 1)$  on the curve. The tangent at  $A$  cuts the  $x$ -axis at  $B$  and the normal at  $A$  cuts the  $y$ -axis at  $C$ .

- (i) Find the coordinates of  $B$  and  $C$ .
- (ii) Find the distance  $AC$ , giving your answer in the form  $\frac{\sqrt{a}}{b}$ , where  $a$  and  $b$  are integers.

(iii) Find the area of the shaded region.

[J13/P11/Q10]

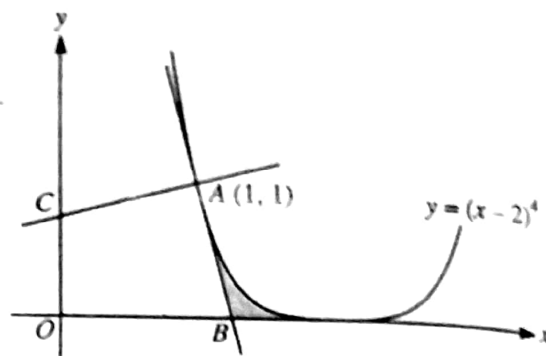

50. A curve is such that  $\frac{dy}{dx} = \frac{6}{x^2}$  and  $(2, 9)$  is a point on the curve. Find the equation of the curve.

[J13/P12/Q1]

51. A curve is such that  $\frac{dy}{dx} = \sqrt{2x+5}$  and  $(2, 5)$  is a point on the curve. Find the equation of the curve.

[J13/P13/Q1]

52. The diagram shows part of the curve  $y = \frac{8}{\sqrt{x}} - x$  and points

$A(1, 7)$  and  $B(4, 0)$  which lie on the curve. The tangent to the curve at  $B$  intersects the line  $x = 1$  at the point  $C$ .

- (i) Find the coordinates of  $C$ .
- (ii) Find the area of the shaded region. [J13/P13/Q11]

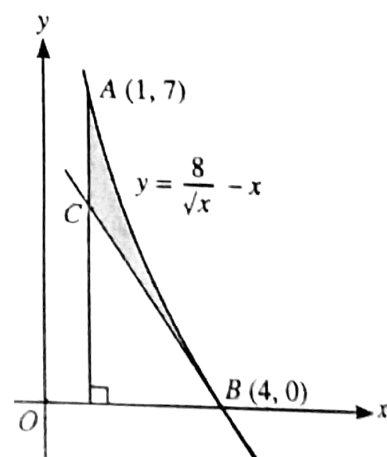

53. The diagram shows the curve  $y = (3 - 2x)^3$  and the tangent to the curve at the point  $(\frac{1}{2}, 8)$ .

- (i) Find the equation of this tangent, giving your answer in the form  $y = mx + c$ .
- (ii) Find the area of the shaded region.

[N13/P11/Q10]

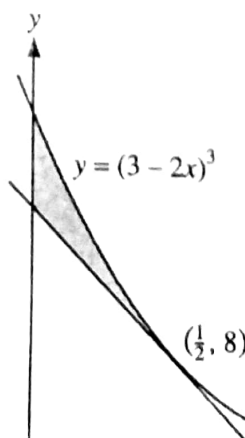

54. The equation of a curve is  $y = \frac{2}{\sqrt{5x-6}}$ .

(i) Find the gradient of the curve at the point where  $x = 2$ .

(ii) Find  $\int \frac{2}{\sqrt{5x-6}} dx$  and hence evaluate  $\int_2^3 \frac{2}{\sqrt{5x-6}} dx$ .

[N13/P12/Q3]

55. The diagram shows part of the curve  $y = \frac{8}{x} + 2x$  and three points A, B and C on the curve with x-coordinates 1, 2 and 5 respectively.

(i) A point P moves along the curve in such a way that its x-coordinate increases at a constant rate of 0.04 units per second. Find the rate at which the y-coordinate of P is changing as P passes through A.

(ii) Find the volume obtained when the shaded region is rotated through  $360^\circ$  about the x-axis.

[N13/P12/Q9]

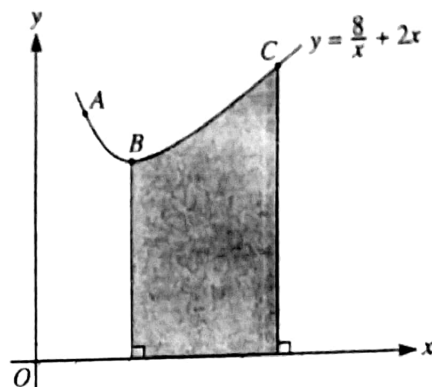

56. A curve has equation  $y = f(x)$ . It is given that  $f'(x) = x^{-\frac{3}{2}} + 1$  and that  $f(4) = 5$ . Find  $f(x)$ .

[N13/P13/Q2]

57. The diagram shows the curve  $y = \sqrt{x^4 + 4x + 4}$ .

(i) Find the equation of the tangent to the curve at the point (0, 2).

(ii) Show that the x-coordinates of the points of intersection of the line  $y = x + 2$  and the curve are given by the equation

$(x+2)^2 = x^4 + 4x + 4$ . Hence find these x-coordinates.

(iii) The region shaded in the diagram is rotated through  $360^\circ$  about the x-axis. Find the volume of revolution.

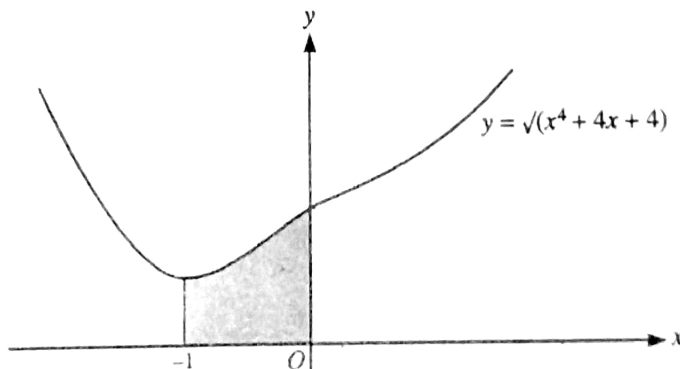

[N13/P13/Q11]

58. A line has equation  $y = 2x + c$  and a curve has equation  $y = 8 - 2x - x^2$ .

(i) For the case where the line is a tangent to the curve, find the value of the constant c.

(ii) For the case where  $c = 11$ , find the x-coordinates of the points of intersection of the line and the curve. Find also, by integration, the area of the region between the line and the curve.

[J14/P11/Q11]

59. The equation of a curve is such that  $\frac{d^2y}{dx^2} = 2x - 1$ . Given that the curve has a minimum point at  $(3, -10)$ , find the coordinates of the maximum point. [J14/P12/Q8]

60. The diagram shows part of the curve  $y = 8 - \sqrt{4 - x}$  and the tangent to the curve at  $P(3, 7)$ .

- (i) Find expressions for  $\frac{dy}{dx}$  and  $\int y \, dx$ .
- (ii) Find the equation of the tangent to the curve at  $P$  in the form  $y = mx + c$ .
- (iii) Find, showing all necessary working, the area of the shaded region.

[J14/P12/Q9]

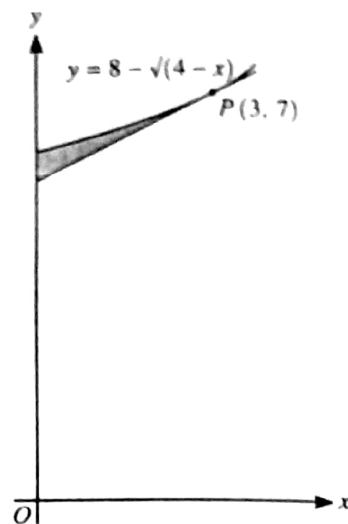

61. The diagram shows the curve  $y = -x^2 + 12x - 20$  and the line  $y = 2x + 1$ . Find, showing all necessary working, the area of the shaded region. [J14/P13/Q10]

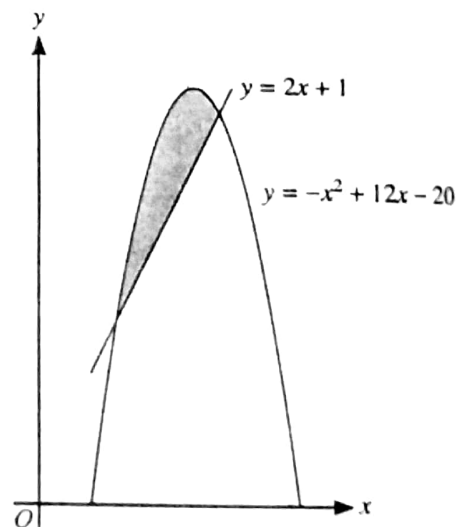

62. The diagram shows part of the curve  $y = x^2 + 1$ . Find the volume obtained when the shaded region is rotated through  $360^\circ$  about the y-axis.

[N14/P12/Q1]

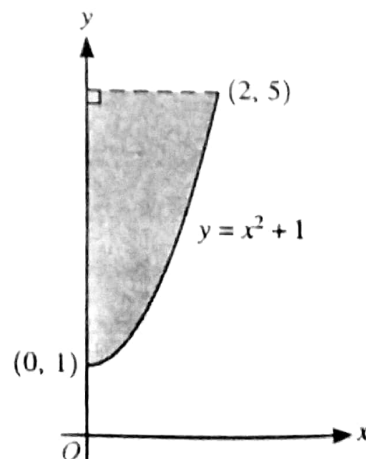

63. The diagram shows parts of the curves  $y = (4x+1)^{\frac{1}{2}}$  and  $y = \frac{1}{2}x^2 + 1$  intersecting at points  $P(0, 1)$  and  $Q(2, 3)$ . The angle between the tangents to the two curves at  $Q$  is  $\alpha$ .

- (i) Find  $\alpha$ , giving your answer in degrees correct to 3 significant figures.
- (ii) Find by integration the area of the shaded region.

[N14/P11/Q11]

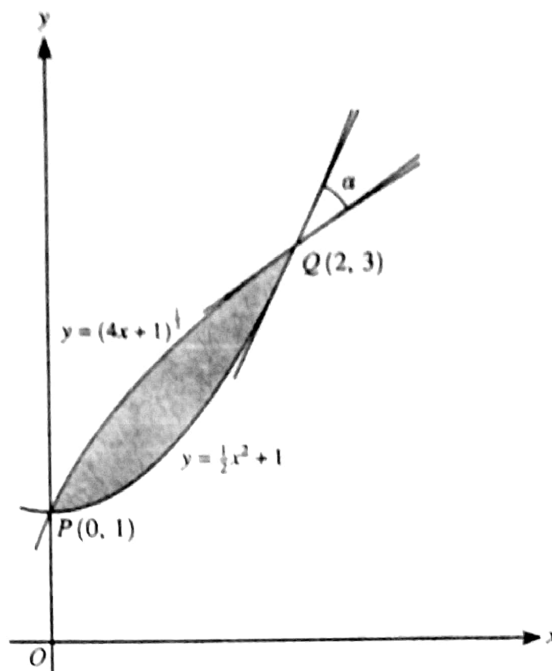

64. The diagram shows parts of the graphs of  $y = x+2$  and  $y = 3\sqrt{x}$  intersecting at points  $A$  and  $B$ .

- (i) Write down an equation satisfied by the  $x$ -coordinates of  $A$  and  $B$ . Solve this equation and hence find the coordinates of  $A$  and  $B$ .
- (ii) Find by integration the area of the shaded region.

[N14/P13/Q9]

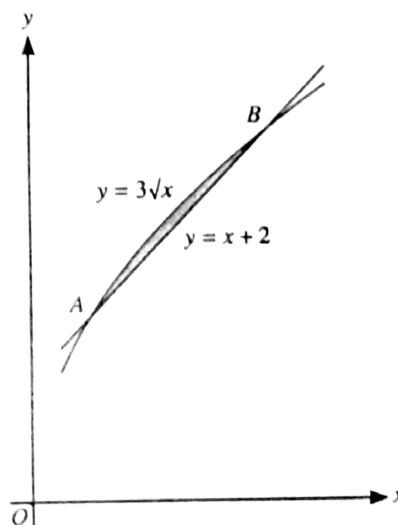

65. The diagram shows part of the curve  $y = \frac{8}{\sqrt{3x+4}}$ .

The curve intersects the  $y$ -axis at  $A(0, 4)$ . The normal to the curve at  $A$  intersects the line  $x = 4$  at the point  $B$ .

- (i) Find the coordinates of  $B$ .
- (ii) Show, with all necessary working, that the areas of the regions marked  $P$  and  $Q$  are equal.

[J15/P11/Q10]

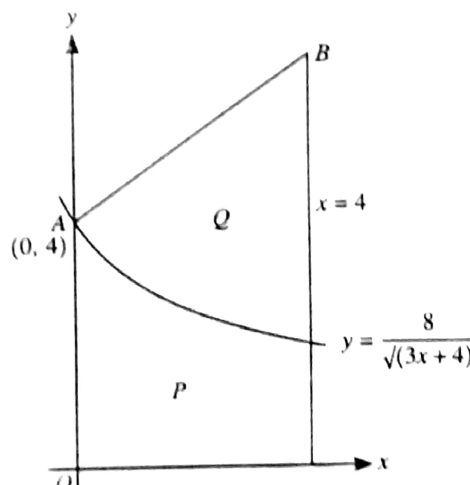

66. The function  $f$  is such that  $f(x) = 5 - 2x^2$  and  $(3, 5)$  is a point on the curve  $y = f(x)$ . Find  $f(x)$ .  
[J15/P12/Q1]

67. The equation of a curve is  $y = \frac{4}{2x-1}$ .

- (i) Find, showing all necessary working, the volume obtained when the region bounded by the curve, the  $x$ -axis and the lines  $x = 1$  and  $x = 2$  is rotated through  $360^\circ$  about the  $x$ -axis.
- (ii) Given that the line  $2y = x + c$  is a normal to the curve, find the possible values of the constant  $c$ .

[J15/P12/Q10]

68. A curve is such that  $\frac{dy}{dx} = (2x+1)^{\frac{1}{2}}$  and the point  $(4, 7)$  lies on the curve. Find the equation of the curve.  
[J15/P13/Q2]

69. Points  $A(2, 9)$  and  $B(3, 0)$  lie on the curve  $y = 9 + 6x - 3x^2$ , as shown in the diagram. The tangent at  $A$  intersects the  $x$ -axis at  $C$ . Showing all necessary working,

- (i) find the equation of the tangent  $AC$  and hence find the  $x$ -coordinate of  $C$ ,

- (ii) find the area of the shaded region  $ABC$ .

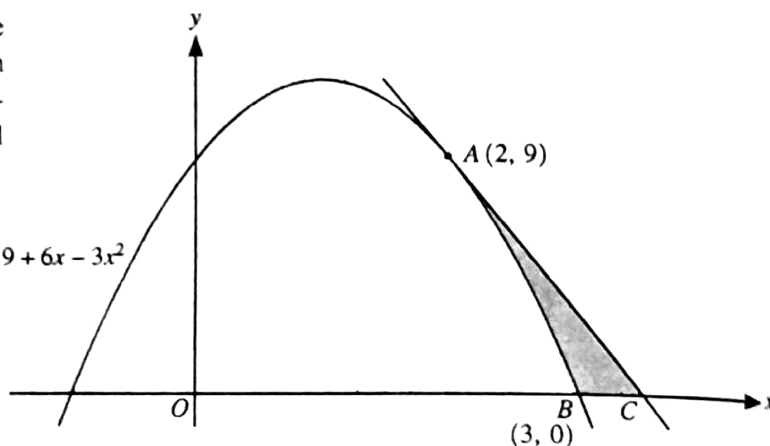

[J15/P13/Q10]

70. The diagram shows part of the curve  $y = (1 + 4x)^{\frac{1}{2}}$  and a point  $P(6, 5)$  lying on the curve. The line  $PQ$  intersects the  $x$ -axis at  $Q(8, 0)$ .

- (i) Show that  $PQ$  is a normal to the curve.
- (ii) Find, showing all necessary working, the exact volume of revolution obtained when the shaded region is rotated through  $360^\circ$  about the  $x$ -axis.

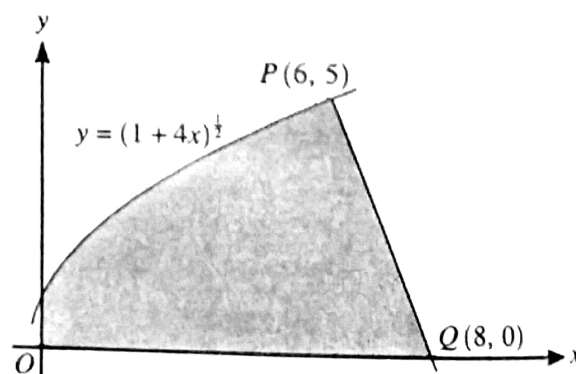

[In part (ii) you may find it useful to apply the fact that the volume,  $V$ , of a cone of base radius  $r$  and vertical height  $h$ , is given by  $V = \frac{1}{3}\pi r^2 h$ .]  
[N15/P11/Q11]



75. The diagram shows part of the curve  $y = (x^3 + 1)^{\frac{1}{2}}$  and the point  $P(2, 3)$  lying on the curve. Find, showing all necessary working, the volume obtained when the shaded region is rotated through  $360^\circ$  about the  $x$ -axis.

[J16/P13/Q2]

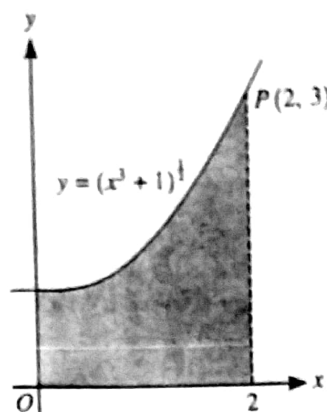

76. A curve is such that  $\frac{dy}{dx} = 6x^2 + \frac{k}{x^3}$  and passes through the point  $P(1, 9)$ . The gradient of the curve at  $P$  is 2.

- (i) Find the value of the constant  $k$ .
- (ii) Find the equation of the curve.

[J16/P13/Q3]

77. The diagram shows parts of the curves  $y = (2x - 1)^2$  and  $y^2 = 1 - 2x$ , intersecting at points  $A$  and  $B$ .

- (i) State the coordinates of  $A$ .
- (ii) Find, showing all necessary working, the area of the shaded region.

[N16/P11/Q7]

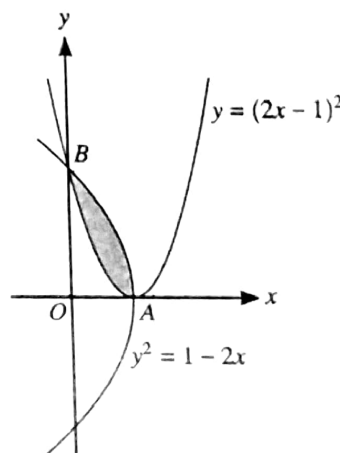

78. A curve is such that  $\frac{dy}{dx} = \frac{8}{\sqrt{4x+1}}$ . The point  $(2, 5)$  lies on the curve. Find the equation of the curve.

[N16/P12/Q1]

79. A curve has equation  $y = (kx - 3)^{-1} + (kx - 3)$ , where  $k$  is a non-zero constant.

- (i) Find the  $x$ -coordinates of the stationary points in terms of  $k$ , and determine the nature of each stationary point, justifying your answers.
- (ii) The diagram shows part of the curve for the case when  $k = 1$ . Showing all necessary working, find the volume obtained when the region between the curve, the  $x$ -axis, the  $y$ -axis and the line  $x = 2$ , shown shaded in the diagram, is rotated through  $360^\circ$  about the  $x$ -axis.

[N16/P13/Q11]

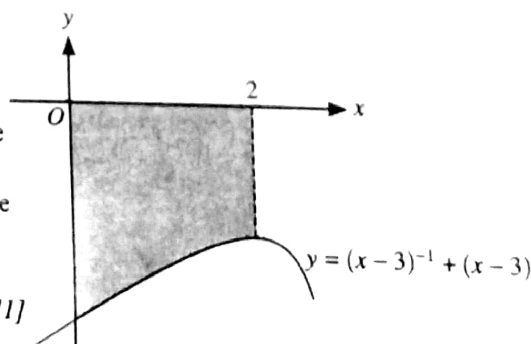

71. The diagram shows part of the curve

$y = \sqrt{9 - 2x^2}$ . The point  $P(2, 1)$  lies on the curve and the normal to the curve at  $P$  intersects the  $x$ -axis at  $A$  and the  $y$ -axis at  $B$ .

(i) Show that  $B$  is the mid-point of  $AP$ .

The shaded region is bounded by the curve, the  $y$ -axis and the line  $y = 1$ .

(ii) Find, showing all necessary working, the exact volume obtained when the shaded region is rotated through  $360^\circ$  about the  $y$ -axis.

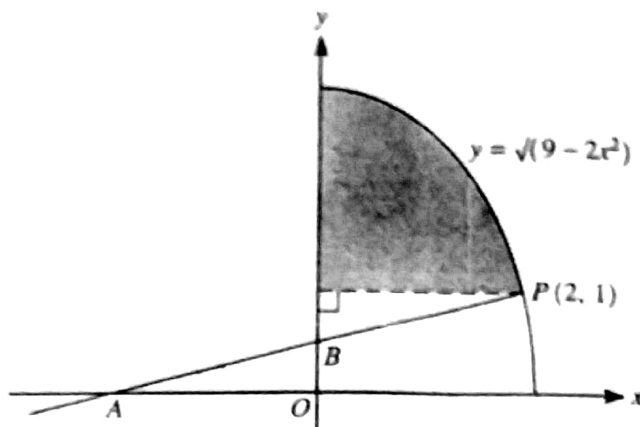

[N15/P12/Q10]

72. The function  $f$  is defined by  $f(x) = 2x + (x+1)^{-2}$  for  $x > -1$ .

(i) Find  $f'(x)$  and  $f''(x)$  and hence verify that the function  $f$  has a minimum value at  $x = 0$ .

The points  $A(-\frac{1}{2}, 3)$  and  $B(1, 2\frac{1}{4})$  lie on the curve  $y = 2x + (x+1)^{-2}$ , as shown in the diagram.

(ii) Find the distance  $AB$ .

(iii) Find, showing all necessary working, the area of the shaded region.

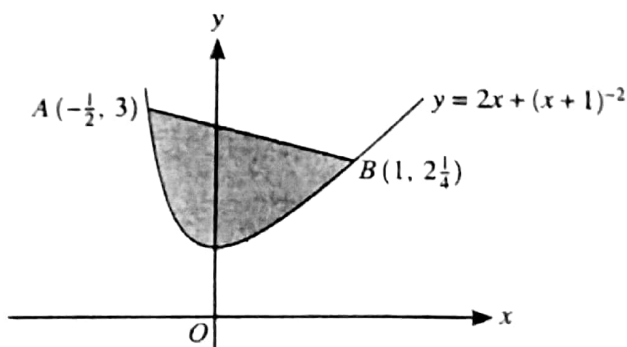

[N15/P13/Q10]

73. The diagram shows part of the curve

$x = \frac{12}{y^2} - 2$ . The shaded region is

bounded by the curve, the  $y$ -axis and the lines  $y = 1$  and  $y = 2$ . Showing all necessary working, find the volume, in terms of  $\pi$ , when this shaded region is rotated through  $360^\circ$  about the  $y$ -axis

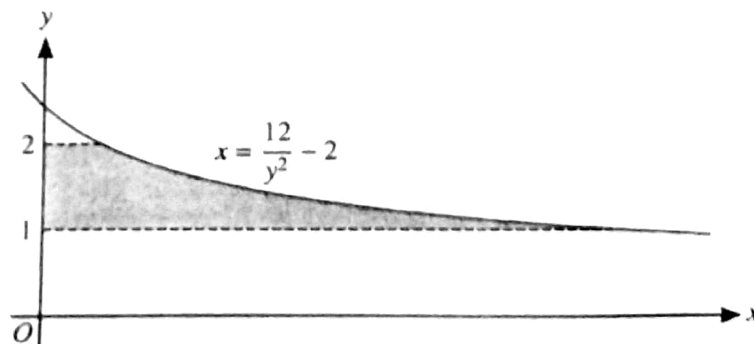

[J16/P11/Q3]

74. A curve is such that  $\frac{dy}{dx} = \frac{8}{y}$ . Given that the curve passes through  $(2, 7)$ , find the equation of

the cu

# ANSWERS

## Topic 10 - Integration

7. (i) Equation of normal at P:  $x + 2y = 17$

Subst.  $y = 0$ , gives,  $Q(17, 0)$

Subst.  $x = 0$ , gives,  $R(0, \frac{17}{2})$

Mid-point of  $QR = (\frac{17}{2}, \frac{17}{4})$

(ii)  $\int dy = 4 \int (6 - 2x)^{-\frac{1}{2}} dx$

$\Rightarrow y = -4\sqrt{6 - 2x} + K$

Subst.  $P(1, 8)$  gives,  $K = 16$

$\therefore$  equation is:  $y = 16 - 4\sqrt{6 - 2x}$

8. (i)  $y = x^3 - 3x^2 + 2x \Rightarrow \frac{dy}{dx} = 3x^2 - 6x + 2$

At  $A(1, 0)$ ,  $\frac{dy}{dx} = -1$ . At  $B(2, 0)$ ,  $\frac{dy}{dx} = 2$

$\therefore$  eq. of tangent at A:  $y = -x + 1$  .....(i)

eq. of tangent at B:  $y = 2x - 4$  .....(ii)

solving simultaneously, x-coordinate of C is  $x = \frac{5}{3}$

(ii) Area of  $R_1 = \int_0^1 (x^3 - 3x^2 + 2x) dx$   
 $= \left[ \frac{x^4}{4} - x^3 + x^2 \right]_0^1 = \frac{1}{4}$

Area of  $R_2 = \int_1^2 (x^3 - 3x^2 + 2x) dx$   
 $= \left[ \frac{x^4}{4} - x^3 + x^2 \right]_1^2 = \left| -\frac{1}{4} \right| = \frac{1}{4}$

9. Volume  $= \pi \int_1^4 y^2 dx$   
 $= \pi \int_1^4 (3x^{\frac{1}{4}})^2 dx = 42\pi \text{ units}^3$

10. Area  $= \int_1^4 2\sqrt{x} dx = \frac{4}{3} \left[ x^{\frac{3}{2}} \right]_1^4 = 9\frac{1}{3} \text{ units}^2$

11. (i)  $\int dy = \int (4 - x) dx \Rightarrow y = 4x - \frac{x^2}{2} + K$   
 Subst.  $P(2, 9)$  gives,  $K = 3$

(ii) At P,  $\frac{dy}{dx} = 2, \Rightarrow$  grad. of normal  $= -\frac{1}{2}$   
 $\therefore$  equation of normal:  $2y + x = 20$

(iii) Equation of curve:  $y = 4x - \frac{x^2}{2} + 3$

Equation of normal:  $y = \frac{20 - x}{2}$

Solving simultaneously gives,  $x = 2$  and  $x = 7$

when  $x = 7$ ,  $y = \frac{20 - 7}{2} = 6.5, \therefore Q(7, 6.5)$

12. (i)  $\int dy = -k \int x^{-3} dx \Rightarrow y = \frac{k}{2x^2} + C$

Subst. (1, 18) gives,  $k = 36 - 2C$  .....(i)

Subst. (4, 3) gives,  $96 = k + 32C$  .....(ii)

solving simultaneously gives,  $C = 2$  and  $k = 32$

$\therefore$  equation of the curve is:  $y = \frac{16}{x^2} + 2$

(ii) Shaded area  $= \int_1^6 \left( \frac{16}{x^2} + 2 \right) dx$   
 $= \left[ -\frac{16}{x} + 2x \right]_1^6 = 7.2 \text{ units}^2$

13. (i) Area under the curve  $PQ = \int_0^1 \sqrt{3x+1} dx$   
 $= \frac{2}{9} \left[ (3x+1)^{\frac{3}{2}} \right]_0^1 = \frac{14}{9} \text{ units}^2$

Shaded area = area of rectangle  
 - area under PQ  
 $= 2 - \frac{14}{9} = 0.444 \text{ sq. units}$

(ii) Volume  $= \pi \int_0^1 (2)^2 dx - \pi \int_0^1 (\sqrt{3x+1})^2 dx$   
 $= 4\pi \left[ x \right]_0^1 - \pi \left[ \frac{3x^2}{2} + x \right]_0^1 = \frac{3}{2} \pi \text{ units}^3$

$\therefore$  equation of curve is:  $y = 4x - \frac{x^2}{2} + 3$

(iii)

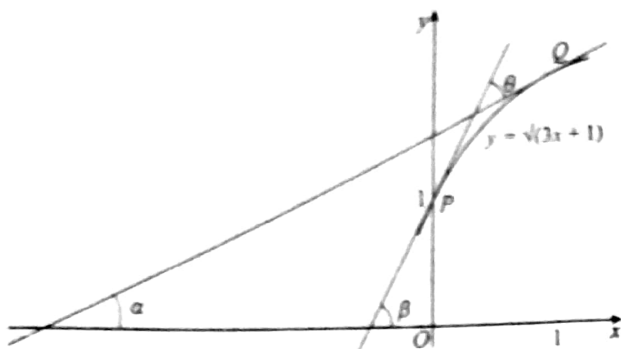

Grad. of tangent at  $P(0, 1)$ :  $\frac{dy}{dx} = \frac{3}{2}$

$\therefore \tan \beta = \frac{3}{2} \Rightarrow \beta = 56.3^\circ$

grad. of tangent at  $Q(1, 2)$ :  $\frac{dy}{dx} = \frac{3}{4}$

$\therefore \tan \alpha = \frac{3}{4} \Rightarrow \alpha = 36.9^\circ$

Angle  $\theta$  between the two tangents is,  
 $\theta = \beta - \alpha = 19.4^\circ$

14. (i)  $\frac{dy}{dx} = \frac{-18}{(3x-2)^2}$ , at  $x=2$ ,  $\frac{dy}{dx} = -\frac{9}{8}$

(ii) Volume =  $\pi \int_1^2 \left(\frac{6}{3x-2}\right)^2 dx$   
 $= 36 \pi \left[ \frac{(3x-2)^{-1}}{(-1)(3)} \right]_1^2 = 9\pi \text{ unit}^3$

15. (i)  $\frac{dy}{dx} = 4x^3 + 4 = 0 \Rightarrow x = -1$   
 $y = (-1)^4 + 4(-1) + 9 = 6$ ,  $\therefore$  st. point  $(-1, 6)$

at  $x = -1$ ,  $\frac{d^2y}{dx^2} = 12$ ,  $\therefore$  minimum

(ii) Area =  $\int_0^1 (x^4 + 4x + 9) dx$   
 $= \left[ \frac{x^5}{5} + 2x^2 + 9x \right]_0^1 = 11.2 \text{ unit}^2$

16. (i) At  $x=2$ ,  $\frac{dy}{dx} = k-4$ , at  $x=3$ ,  $\frac{dy}{dx} = k-6$   
 $(k-4)(k-6) = -1$   
 $\Rightarrow k^2 - 10k + 25 = 0 \Rightarrow k = 5$

(ii)  $\int dy = \int (5-2x) dx \Rightarrow y = 5x - x^2 + C$   
 Subst.  $(4, 9)$  gives,  $C = 5$

(iii)  $\frac{dy}{dt} = \frac{dy}{dx} \times \frac{dx}{dt}$   
 $= -\frac{3}{2} \times 0.012 = -0.018 \text{ units/sec}$

17.  $\int dy = \int (3x^{\frac{1}{2}} - x) dx \Rightarrow y = 6\sqrt{x} - \frac{1}{2}x^2 + K$   
 Subst.  $(4, 6)$  gives,  $K = 2$   
 $\therefore$  equation:  $y = 6\sqrt{x} - \frac{1}{2}x^2 + 2$

18. Volume =  $\pi \int_0^2 (3(2x+5)^{-1})^2 dx$   
 $= 9\pi \int_0^2 (2x+5)^{-2} dx$   
 $= \frac{9\pi}{-2} \left[ \frac{1}{2x+5} \right]_0^2 = \frac{2}{5}\pi \text{ units}^3$

19. When  $y=5$ ,  $x^2 - 6x + 5 = 0 \Rightarrow x=1$  or  $x=5$

Shaded area =  $\int_1^5 y dx - \text{area of rectangle}$   
 $= \int_1^5 (6x - x^2) dx - 20$   
 $= \left[ 3x^2 - \frac{x^3}{3} \right]_1^5 - 20 = \frac{32}{3} \text{ sq. units}$

20. (i)  $\int dy = \int (3x^{\frac{1}{2}} - 6) dx \Rightarrow y = 2x^{\frac{3}{2}} - 6x + K$   
 Subst.  $(9, 2)$  gives,  $K = 2$

$\therefore$  equation of the curve:  $y = 2x^{\frac{3}{2}} - 6x + 2$

(ii)  $\frac{dy}{dx} = 3x^{\frac{1}{2}} - 6 = 0 \Rightarrow x = 4$   
 at  $x = 4$ ,  $\frac{d^2y}{dx^2} = \frac{3}{4}$ ,  $\therefore$  Minimum

21. Volume =  $\pi \int_1^3 \left(\frac{a}{x}\right)^2 dx$   
 $\Rightarrow 24\pi = \pi a^2 \int_1^3 x^{-2} dx \Rightarrow 24 = a^2 \left[ -\frac{1}{x} \right]_1^3$   
 $\Rightarrow 24 = a^2 \left( \frac{2}{3} \right) \Rightarrow a = \pm 6$ ,  $\therefore a = 6$

22. Solving simultaneously, equations of curve and line, we get the upper and lower limits, i.e.  $x = -1$ , and 3

$$\begin{aligned} \text{Shaded area} &= \int_{-1}^3 ((7-2x) - (x-2)^2) dx \\ &= \int_{-1}^3 (3+2x-x^2) dx \\ &= \left( 3x + x^2 - \frac{x^3}{3} \right)_{-1}^3 = 10\frac{2}{3} \text{ unit}^2 \end{aligned}$$

23. (i) At  $x = 2$ ,  $\frac{dy}{dx} = 3$ ,  $\therefore$  grad. of normal  $= -\frac{1}{3}$   
Equation of normal:  $3y + x = 35$

$$(ii) \int dy = \int 6(3x-2)^{\frac{1}{2}} dx$$

$$\Rightarrow y = 4(3x-2)^{\frac{3}{2}} + K$$

$$\text{Subst. } (2, 11) \text{ gives, } K = 3$$

$$\therefore \text{ equation: } y = 4\sqrt{3x-2} + 3$$

24. (i) Subst.  $y = 5$  into eq. of curve, gives,  $A(1, 5)$  and  $B(4, 5)$ .

$$\text{For } M, \frac{dy}{dx} = 1 - \frac{4}{x^2} = 0 \Rightarrow x = 2$$

$$\Rightarrow y = 2 + \frac{4}{2} = 4, \therefore M(2, 4)$$

$$\begin{aligned} (ii) \text{ Volume} &= \pi \int_1^4 5^2 dx - \pi \int_1^4 \left(x + \frac{4}{x}\right)^2 dx \\ &= \pi \int_1^4 25 dx - \pi \int_1^4 \left(x^2 + 8 + \frac{16}{x^2}\right) dx \\ &= \pi \left[ 25x \right]_1^4 - \pi \left[ \frac{x^3}{3} + 8x - \frac{16}{x} \right]_1^4 \\ &= 75\pi - 57\pi = 18\pi \text{ units}^3 \end{aligned}$$

$$25. \int \left(x + \frac{1}{x}\right)^2 dx = \frac{x^3}{3} + 2x - \frac{1}{x} + C$$

$$26. (i) \frac{dy}{dx} = \frac{9}{(2-x)^2}$$

$$\text{No stationary points as } \frac{9}{(2-x)^2} \neq 0$$

$$(ii) \text{ Volume} = \pi \int_0^1 \left(\frac{9}{2-x}\right)^2 dx$$

$$= \pi \left[ \frac{81}{2-x} \right]_0^1 = \frac{81}{2} \pi \text{ units}^3$$

- (iii) Subst. line into curve, gives,

$$x^2 + (k-2)x - 2k + 9 = 0$$

apply, Discriminant  $> 0$

$$\Rightarrow (k-2)^2 - 4(-2k+9) > 0$$

$$\Rightarrow k^2 + 4k - 32 > 0 \Rightarrow k < -8, k > 4$$

$$27. (i) \text{ At } x = 0, y = \frac{1}{(0+1)^4} = 1, \therefore A(0, 1)$$

$$\text{At } x = 5, y = \frac{1}{(5+1)^4} = \frac{1}{2}, \therefore B(5, \frac{1}{2})$$

$$\text{Equation of } AB: y - 1 = -\frac{1}{10}(x - 0)$$

$$\Rightarrow y = -\frac{1}{10}x + 1$$

$$(ii) \text{ Vol.} = \pi \int_0^5 \left( -\frac{1}{10}x + 1 \right)^2 - \left( (3x+1)^{-\frac{1}{4}} \right)^2 dx$$

$$= \pi \left( -\frac{10}{3} \left( -\frac{1}{10}x + 1 \right)^3 - \frac{2}{3} (3x+1)^{\frac{3}{2}} \right)_0^5$$

$$= \frac{11}{12} \pi \text{ units}^3$$

$$28. (i) f'(x) > 0 \Rightarrow 3x^2 + 2x - 5 > 0$$

$$\Rightarrow (x-1)(3x+5) > 0 \Rightarrow x < -\frac{5}{3}, x > 1$$

$$(ii) f(x) = \int (3x^2 + 2x - 5) dx$$

$$= x^3 + x^2 - 5x + K$$

$$\text{Subst. } (1, 3) \text{ gives, } K = 6$$

$$\therefore f(x) = x^3 + x^2 - 5x + 6$$

$$29. (i) \text{ Eliminating } y, \text{ we have, } 9 - x^3 = \frac{8}{x^3}$$

$$\Rightarrow x^6 - 9x^3 + 8 = 0 \Rightarrow (x^3 - 1)(x^3 - 8) = 0$$

$$\Rightarrow x = 1 \text{ or } x = 2, \therefore a = 1, b = 2$$

$$(ii) \text{ Shaded area} = \int_1^2 ((9-x^3) - (8x^{-3})) dx$$

$$= \left[ 9x - \frac{x^4}{4} + \frac{4}{x^2} \right]_1^2 = \frac{9}{4} \text{ unit}^2$$

- (iii) Equating the gradients of both curves,

$$-3x^2 = -\frac{24}{x^4} \Rightarrow x^6 = 8 \Rightarrow x = c = \sqrt[6]{8}$$



30. (i)

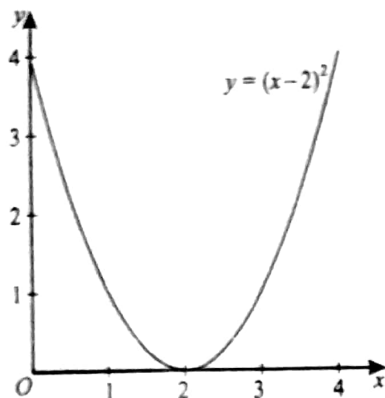

$$(ii) \text{ Volume} = \pi \int_0^2 (x-2)^4 dx$$

$$= \pi \left[ \frac{(x-2)^5}{5} \right]_0^2 = \frac{32}{5} \pi \text{ units}^3$$

31. (i)  $\int dy = \int 3(1+2x)^{-2} dx \Rightarrow y = \frac{-3}{2(1+2x)} + K$

Subst.  $(1, \frac{1}{2})$  gives,  $K = 1$

$\therefore$  equation of the curve:  $y = -\frac{3}{2(1+2x)} + 1$

(ii)  $\frac{3}{(1+2x)^2} < \frac{1}{3}$

$$\Rightarrow 9 < (1+2x)^2 \Rightarrow x^2 + x - 2 > 0$$

$$\Rightarrow (x+2)(x-1) > 0 \Rightarrow x < -2, x > 1$$

32.  $\int \left( x^3 + \frac{1}{x^3} \right) dx = \frac{1}{4} x^4 - \frac{1}{2x^2} + K$

33. (i) Subst.  $y = 0$ , into curve, gives,  $A(16, 0)$

For  $M$ ,  $\frac{dy}{dx} = \frac{2}{\sqrt{x}} - 1 = 0 \Rightarrow x = 4$

at  $x = 4$ ,  $y = 4\sqrt{4} - 4 = 4$ ,  $\therefore M$  is  $(4, 4)$ .

(ii)  $V = \pi \int_0^{16} (4\sqrt{x} - x)^2 dx$

$$= \pi \int_0^{16} (16x - 8x^{\frac{3}{2}} + x^2) dx$$

$$= \pi \left[ 8x^2 - \frac{16}{5} x^{\frac{5}{2}} + \frac{x^3}{3} \right]_0^{16} = 136 \frac{8}{15} \pi \text{ unit}^3$$

34. (a)  $\frac{d}{dx} \left( \frac{2x^3 + 5}{x} \right) = \frac{d}{dx} (2x^2 + 5x^{-1})$

$$= 4x - \frac{5}{x^2}$$

(b)  $\int (3x-2)^5 dx = \frac{(3x-2)^6}{18} + C$

$$\int_0^1 (3x-2)^5 dx = \left[ \frac{(3x-2)^6}{18} \right]_0^1 = -\frac{7}{2}$$

35. (i)  $y = \int \left( \frac{2}{\sqrt{x}} - 1 \right) dx = 4\sqrt{x} - x + K$

Subst.  $P(9, 5)$  gives,  $K = 2$

$\therefore$  equation of curve is:  $y = 4\sqrt{x} - x + 2$

(ii)  $\frac{dy}{dx} = \frac{2}{\sqrt{x}} - 1 = 0 \Rightarrow x = 4$

$\therefore y = 4\sqrt{4} - 4 + 2 = 6$ ,  $\therefore$  st. point is  $(4, 6)$

(iii)  $\frac{d^2y}{dx^2} = -x^{-\frac{3}{2}}$

At  $x = 4$ ,  $\frac{d^2y}{dx^2} = -\frac{1}{8} < 0$ ,  $\therefore$  Maximum.

(iv) At  $x = 9$ ,  $\frac{dy}{dx} = -\frac{1}{3}$ ,  $\Rightarrow$  grad. of normal = 3

$\Rightarrow \tan \theta = 3 \Rightarrow \theta = \tan^{-1} 3$

$\therefore k = 3$

36. (i)  $f'(x) = 2x - 6 = 0 \Rightarrow x = 3$

(ii)  $f(x) = \int (2x - 6) dx = x^2 - 6x + C$

Subst.  $(3, -4)$  gives,  $C = 5$

$\therefore f(x) = x^2 - 6x + 5$

37. (i)  $\frac{dy}{dx} = \frac{4-x}{\sqrt{8x-x^2}}$

for stationary point,  $\frac{4-x}{\sqrt{8x-x^2}} = 0 \Rightarrow x = 4$

$\Rightarrow y = \sqrt{8(4) - (4)^2} = 4$ ,  $\therefore$  st. point  $(4, 4)$

(ii) For  $x$ -intercepts, put  $y = 0$ , into eq. of curve,

$\Rightarrow \sqrt{8x-x^2} = 0 \Rightarrow x = 0, x = 8$

Volume =  $\pi \int_0^8 \left( \sqrt{8x-x^2} \right)^2 dx$

$= \pi \left[ 4x^2 - \frac{1}{3} x^3 \right]_0^8 = 85 \frac{1}{3} \pi \text{ units}^3$

38. (i) Subst.  $x = 0$ , into eq. of curve, gives  $B(0, 1)$

Subst.  $y = 3$ , into eq. of curve, gives  $C(4, 3)$

(ii)  $m = \frac{1}{\sqrt{1+2x}}$ . At  $C(4, 3)$ ,  $m = \frac{1}{3}$ ,  $\Rightarrow m_N = -3$

$\therefore$  Eq. of normal:  $y + 3x = 15$

$$\begin{aligned} \text{(iii) Volume} &= \pi \int_0^1 x^2 dy \\ &= \pi \int_0^1 \left( \frac{y^2-1}{2} \right)^2 dy \\ &= \frac{1}{4} \pi \left[ \frac{1}{5} y^5 - \frac{2}{3} y^3 + y \right]_0^1 = \frac{2\pi}{15} \text{ units}^3 \end{aligned}$$

$$\begin{aligned} \text{39. (i) Shaded area} &= \int_{-1}^0 (\sqrt{x+1} - (x+1)) dx \\ &= \left[ \frac{2}{3}(x+1)^{\frac{3}{2}} - \frac{1}{2}x^2 - x \right]_{-1}^0 = \frac{1}{6} \text{ units}^2 \end{aligned}$$

$$\begin{aligned} \text{(ii) Volume} &= \pi \int_0^1 (y^2-1)^2 - (y-1)^2 dy \\ &= \pi \int_0^1 (y^4 - 3y^2 + 2y) dy \\ &= \pi \left[ \frac{1}{5} y^5 - y^3 + y^2 \right]_0^1 = \frac{1}{5} \pi \text{ units}^3 \end{aligned}$$

$$\text{40. (i) } y = \frac{2}{\sqrt{x+1}} \Rightarrow y^2 = \frac{4}{x+1} \Rightarrow x = \frac{4}{y^2} - 1$$

$$\text{(ii) } \int \left( \frac{4}{y^2} - 1 \right) dy = -\frac{4}{y} - y + K$$

Lower limit = 1, Upper limit = 2

$$\begin{aligned} \therefore \text{Shaded area} &= \int_1^2 \left( \frac{4}{y^2} - 1 \right) dy \\ &= \left[ -\frac{4}{y} - y \right]_1^2 = 1 \text{ units}^2 \end{aligned}$$

$$\begin{aligned} \text{(iii) Volume} &= \pi \int_1^2 \left( \frac{4}{y^2} - 1 \right)^2 dy \\ &= \pi \int_1^2 \left( \frac{16}{y^4} - \frac{8}{y^2} + 1 \right) dy \\ &= \pi \left[ -\frac{16}{3y^3} + \frac{8}{y} + y \right]_1^2 = \frac{5}{3} \pi \text{ units}^3 \end{aligned}$$

$$\begin{aligned} \text{41. Volume} &= \pi \int_2^3 \left( \frac{6}{2x-3} \right)^2 dx \\ &= 36\pi \int_2^3 (2x-3)^{-2} dx \\ &= -18\pi \left[ \frac{1}{2x-3} \right]_2^3 = 12\pi \text{ unit}^3 \end{aligned}$$

$$\text{42. (i) For point A, } \frac{dy}{dx} = -2x+8=0 \Rightarrow x=4$$

$$\Rightarrow y = -(4)^2 + 8(4) - 10 = 6 \quad \therefore A \text{ is } (4, 6)$$

$$\text{Eq. of BA, through } A(4, 6) \text{ is: } y = 2x - 2$$

Solving simultaneously, eq. of curve and eq. of BA, we have,  $x = 2$  or  $x = 4$

put  $x = 2$  into BA, gives  $y = 2 \quad \therefore B \text{ is } (2, 2)$

$$\begin{aligned} \text{(ii) } \int y dx &= \int (-x^2 + 8x - 10) dx \\ &= -\frac{1}{3}x^3 + 4x^2 - 10x + C \end{aligned}$$

$$\text{Shaded area} = \int_2^4 y dx$$

$$= \left[ -\frac{1}{3}x^3 + 4x^2 - 10x \right]_2^4 = 9\frac{1}{3} \text{ units}^2$$

43. Subst.  $x = 0$ , gives  $A(0, 2)$

$$\text{Volume} = \pi \int_1^2 \left( \frac{8}{y^2} - 2 \right)^2 dy$$

$$= \pi \int_1^2 \left( \frac{64}{y^4} - \frac{32}{y^2} + 4 \right) dy$$

$$= \pi \left[ -\frac{64}{3y^3} + \frac{32}{y} + 4y \right]_1^2 = \frac{20}{3} \pi \text{ units}^3$$

$$\text{44. (i) } \int \frac{d}{dx} \left( \frac{dy}{dx} \right) = \int -4x dx \Rightarrow \frac{dy}{dx} = -2x^2 + C$$

$$\frac{dy}{dx} = 0 \text{ when } x = 2, \Rightarrow C = 8$$

$$\therefore \frac{dy}{dx} = -2x^2 + 8$$

$$y = \int (-2x^2 + 8) dx = -\frac{2}{3}x^3 + 8x + K$$

$$\text{Subst. } (2, 12) \text{ gives, } K = \frac{4}{3}$$

$$\therefore y = -\frac{2}{3}x^3 + 8x + \frac{4}{3}$$

$$\text{(ii) } \frac{dy}{dx} = -2x^2 + 8, \text{ at } x = 3, \frac{dy}{dx} = -10$$

$$\frac{dy}{dt} = \frac{dy}{dx} \times \frac{dx}{dt} = -0.5 \text{ units/s, Decreasing.}$$

$$\text{45. } \int dy = \int \left( -\frac{8}{x^3} - 1 \right) dx \Rightarrow y = \frac{4}{x^2} - x + K$$

Subst. (2, 4) gives,  $K = 5$

$\therefore$  equation of the curve:  $y = \frac{4}{x^2} - x + 5$

46. (i) Subst. eq. of line into eq. of curve, we have  
 $2x^2 - 11x + 5 = 0 \Rightarrow (2x-1)(x-5) = 0$   
 $\Rightarrow x = \frac{1}{2}$  or  $5, \therefore a = 5$

(ii) Shaded area =  $\int_{\frac{1}{2}}^5 \left( (\sqrt{2x-1}) - \frac{2x-1}{3} \right) dx$   
 $= \int_{\frac{1}{2}}^5 \left( (2x-1)^{\frac{1}{2}} - \frac{2}{3}x + \frac{1}{3} \right) dx$   
 $= \left[ \frac{(2x-1)^{\frac{3}{2}}}{\frac{3}{2}} - \frac{1}{3}x^2 + \frac{1}{3}x \right]_{\frac{1}{2}}^5 = \frac{9}{4} \text{ units}^2$

47. (i)  $\frac{dy}{dx} = -\frac{18}{(2x+3)^2}$ , at  $A(3, 1), \frac{dy}{dx} = -\frac{2}{9}$   
 $\therefore$  Equation of tangent at  $A: 2x + 9y = 15$

(ii) Subst.  $x = 0$ , into eq. of  $AC$  gives  $y = 1.67$   
 $\therefore C$  is  $(0, 1.67), \Rightarrow C$  is nearer to  $B$ .

(iii) Volume =  $\pi \int_0^3 \left( \frac{9}{2x+3} \right)^2 dx$   
 $= 81\pi \int_0^3 (2x+3)^{-2} dx$   
 $= -\frac{81}{2}\pi \left[ \frac{1}{2x+3} \right]_0^3 = 9\pi \text{ units}^3$

48. (i) Subst.  $y = 0$ , into eq. of curve,  
 $x(x-2)^2 = 0 \Rightarrow x = 0$  or  $2, \therefore a = 2$

(ii)  $\frac{dy}{dx} = 3x^2 - 8x + 4 = 0 \Rightarrow (x-2)(3x-2) = 0$   
 $\Rightarrow x = 2$  or  $x = \frac{2}{3}, \therefore b = \frac{2}{3}$

(iii) Shaded area =  $\int_0^2 x(x-2)^2 dx$   
 $= \int_0^2 (x^3 - 4x^2 + 4x) dx$   
 $= \left[ \frac{x^4}{4} - \frac{4}{3}x^3 + 2x^2 \right]_0^2 = \frac{4}{3} \text{ units}^2$

(iv) For min. grad,  $\frac{d^2y}{dx^2} = 6x - 8 = 0 \Rightarrow x = \frac{4}{3}$   
 $\therefore \frac{dy}{dx} = 3\left(\frac{4}{3}\right)^2 - 8\left(\frac{4}{3}\right) + 4 = -\frac{4}{3}, \therefore m = -\frac{4}{3}$

49. (i) Equation of  $AB: y + 4x = 5$

At  $B, y = 0, \therefore B$  is  $\left(\frac{5}{4}, 0\right)$

Equation of  $AC: 4y - x = 3$

At  $C, x = 0, \therefore C$  is  $\left(0, \frac{3}{4}\right)$

(ii)  $|AC| = \sqrt{(1-0)^2 + (1-\frac{3}{4})^2} = \frac{\sqrt{17}}{4}$

(iii) Area under curve =  $\int_1^2 (x-2)^4 dx$   
 $= \left[ \frac{(x-2)^5}{5} \right]_1^2 = \frac{1}{5} \text{ unit}^2$

Shaded area = area under curve - area of  $\Delta$   
 $= \frac{1}{5} - \frac{1}{2}(1)\left(\frac{5}{4}-1\right) = \frac{3}{40} \text{ unit}^2$

50.  $y = \int \frac{6}{x^2} dx = -\frac{6}{x} + K$   
 Subst.  $(2, 9)$  gives,  $K = 12$   
 $\therefore$  equation of curve:  $y = -\frac{6}{x} + 12$

51.  $y = \int (2x+5)^{\frac{1}{2}} dx = \frac{(2x+5)^{\frac{3}{2}}}{\frac{3}{2}} + C$   
 Subst.  $(2, 5)$  gives,  $C = -4$

$\therefore$  equation of curve:  $y = \frac{(2x+5)^{\frac{3}{2}}}{3} - 4$

52. (i)  $\frac{dy}{dx} = -4x^{\frac{3}{2}} - 1$ , At  $B(4, 0), \frac{dy}{dx} = -\frac{3}{2}$   
 $\therefore$  Equation of  $BC: 2y + 3x = 12$

Put  $x = 1$ , in  $BC$  gives  $y = \frac{9}{2}, \therefore C$  is  $\left(1, \frac{9}{2}\right)$

(ii) Area under curve  $AB = \int_1^4 (8x^{\frac{1}{2}} - x) dx$   
 $= \left[ 16x^{\frac{3}{2}} - \frac{x^2}{2} \right]_1^4 = \frac{17}{2}$

Area under tangent  $BC = \frac{1}{2}(3)\left(\frac{9}{2}\right) = \frac{27}{4}$

$\therefore$  Shaded area =  $\frac{17}{2} - \frac{27}{4} = \frac{7}{4} \text{ unit}^2$

53. (i)  $\frac{dy}{dx} = -6(3-2x)^2$ , at  $x = \frac{1}{2}, \frac{dy}{dx} = -24$   
 $\therefore$  Eq. of tangent:  $y = -24x + 20$

$$(ii) \text{ Area under curve} = \int_0^{\frac{1}{2}} (3-2x)^3 dx$$

$$= \left[ -\frac{1}{8}(3-2x)^4 \right]_0^{\frac{1}{2}} = \frac{65}{8}$$

Area of trapezium under tangent

$$= \frac{1}{2} \left( \frac{1}{2} \right) (8+20) = 7$$

$$\therefore \text{ Shaded area} = \frac{65}{8} - 7 = \frac{9}{8} \text{ unit}^2$$

$$54. (i) \frac{dy}{dx} = -5(5x-6)^{-\frac{3}{2}}, \text{ At } x=2, \frac{dy}{dx} = -\frac{5}{8}$$

$$(ii) \int \frac{2}{\sqrt{5x-6}} dx = \frac{4}{5}(5x-6)^{\frac{1}{2}} + K$$

$$\int_2^3 \frac{2}{\sqrt{5x-6}} dx = \left[ \frac{4}{5}(5x-6)^{\frac{1}{2}} \right]_2^3 = \frac{4}{5}$$

$$55. (i) \frac{dy}{dx} = -8x^{-2} + 2, \text{ At } x=1, \frac{dy}{dx} = -6$$

$$\therefore \frac{dy}{dt} = -6 \times 0.04 = -0.24 \text{ units/s}$$

$$(ii) \text{ Vol.} = \pi \int_2^5 \left( \frac{8}{x} + 2x \right)^2 dx$$

$$= \pi \int_2^5 \left( \frac{64}{x^2} + 32 + 4x^2 \right) dx$$

$$= \pi \left[ -\frac{64}{x} + 32x + \frac{4}{3}x^3 \right]_2^5 = 852 \text{ units}^3$$

$$56. f(x) = \int (x^{-\frac{3}{2}} + 1) dx = -2x^{-\frac{1}{2}} + x + C$$

Subst. (4, 5) gives,  $K = 2$

$$\therefore f(x) = -2x^{-\frac{1}{2}} + x + 2$$

$$57. (i) \frac{dy}{dx} = \frac{(2x^3+2)}{\sqrt{x^4+4x+4}}, \text{ At } (0, 2), \frac{dy}{dx} = 1$$

$\therefore$  Equation of tangent:  $y-2 = x$

$$(ii) \text{ Eliminating } y, \text{ we get, } x+2 = \sqrt{x^4+4x+4}$$

$$\Rightarrow (x+2)^2 = x^4+4x+4$$

$$\Rightarrow x^2+4x+4 = x^4+4x+4$$

$$\Rightarrow x^2-x^4 = 0 \Rightarrow x=0, \text{ or } x=\pm 1$$

$$(iii) \text{ Volume} = \pi \int_{-1}^0 \left( \sqrt{x^4+4x+4} \right)^2 dx$$

$$= \pi \int_{-1}^0 (x^4+4x+4) dx$$

$$= \pi \left[ \frac{x^5}{5} + 2x^2 + 4x \right]_{-1}^0 = \frac{11}{5} \pi \text{ units}^3$$

58. (i) Subst. Line into curve, we have,

$$x^2+4x+c-8=0$$

Apply,  $b^2-4ac=0$

$$\Rightarrow (4)^2-4(c-8)=0 \Rightarrow c=12$$

(ii) Subst. Line into curve, we have,

$$x^2+4x+3=0 \Rightarrow x=-1 \text{ or } x=-3$$

$$\text{Area} = \int_{-3}^{-1} \left( (8-2x-x^2) - (2x+11) \right) dx$$

$$= \int_{-3}^{-1} (-3-4x-x^2) dx$$

$$= \left[ -3x-2x^2-\frac{x^3}{3} \right]_{-3}^{-1} = \frac{4}{3} \text{ unit}^2$$

$$59. \frac{dy}{dx} = \int (2x-1) dx \Rightarrow \frac{dy}{dx} = x^2-x+C$$

$$\text{At } x=3, \frac{dy}{dx}=0, \Rightarrow C=-6$$

$$y = \int (x^2-x-6) dx \Rightarrow y = \frac{x^3}{3} - \frac{x^2}{2} - 6x + K$$

Subst. (3, -10) gives,  $K = \frac{7}{2}$

$$\therefore y = \frac{x^3}{3} - \frac{x^2}{2} - 6x + \frac{7}{2}$$

$$\text{For max. pt. } \frac{dy}{dx} = x^2-x-6=0 \Rightarrow x=3 \text{ or } -2$$

$$\text{Subst. } x=-2 \text{ into } y \text{ gives, } y = \frac{65}{6}$$

$\therefore$  maximum point is  $(-2, 10\frac{5}{6})$

$$60. (i) \frac{dy}{dx} = \frac{1}{2\sqrt{4-x}}$$

$$\int y dx = 8x + \frac{2}{3}(4-x)^{\frac{3}{2}} + K$$

$$(ii) \text{ At } x=3, \frac{dy}{dx} = \frac{1}{2}$$

$$\text{Equation: } y-7 = \frac{1}{2}(x-3) \Rightarrow y = \frac{1}{2}(x+11)$$

(iii) Shaded area  
 = area under curve - area under tangent line  

$$= \int_0^3 (8 - \sqrt{4-x}) dx - \int_0^3 \frac{1}{2}(x+11) dx$$

$$= \left[ 8x + \frac{2}{3}(4-x)^{\frac{3}{2}} \right]_0^3 - \left[ \frac{x^2}{2} + 11x \right]_0^3$$

$$= \frac{58}{3} - \frac{75}{4} = \frac{7}{12} \text{ units}^2$$

61. The line meets the curve at  $x=3$  and  $x=7$   
 Shaded area = area under curve - area under line  

$$= \int_3^7 (-x^2 + 12x - 20) dx - \int_3^7 (2x+1) dx$$

$$= \left[ -\frac{x^3}{3} + 6x^2 - 20x \right]_3^7 - \left[ x^2 + x \right]_3^7$$

$$= \frac{164}{3} - 44 = \frac{32}{3} \text{ units}^2$$

62.  $y = x^2 + 1 \Rightarrow x^2 = y - 1$   
 Volume =  $\pi \int_1^5 (y-1) dy = \pi \left[ \frac{y^2}{2} - y \right]_1^5$   

$$= 8\pi \text{ units}^3$$

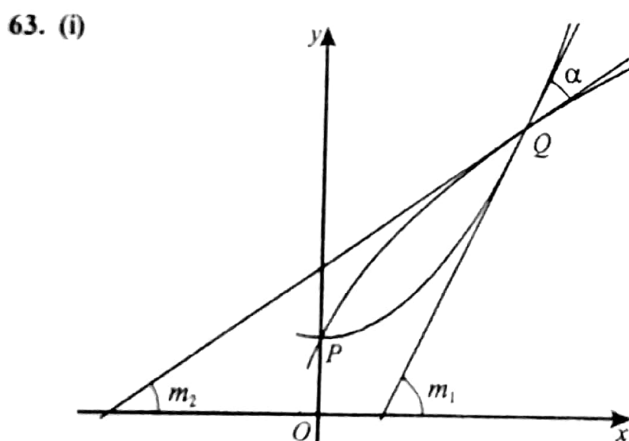

For  $y = \frac{1}{2}x^2 + 1$ , grad. at  $Q(2, 3)$ :  $\frac{dy}{dx} = 2$   
 $\Rightarrow \tan m_1 = 2 \Rightarrow m_1 = 63.4^\circ$

For  $y = (4x+1)^2$ , grad. at  $Q$ :  $\frac{dy}{dx} = \frac{2}{3}$

$\Rightarrow \tan m_2 = \frac{2}{3} \Rightarrow m_2 = 33.7^\circ$

$\therefore \alpha = m_1 - m_2 = 29.7^\circ$

(ii) Shaded area =  $\int_0^2 (4x+1)^{\frac{1}{2}} dx - \int_0^2 \left(\frac{1}{2}x^2 + 1\right) dx$   

$$= \left[ \frac{(4x+1)^{\frac{3}{2}}}{6} \right]_0^2 - \left[ \frac{x^3}{6} + x \right]_0^2$$

$$= \frac{13}{3} - \frac{10}{3} = 1 \text{ units}^2$$

64. (i)  $3\sqrt{x} = x + 2$   
 $\Rightarrow 9x = x^2 + 4x + 4 \Rightarrow x^2 - 5x + 4 = 0$   
 $\therefore x = 1$  or  $x = 4$

When  $x = 1$ ,  $y = 1 + 2 = 3$ ,  $\therefore A(1, 3)$

When  $x = 4$ ,  $y = 4 + 2 = 6$ ,  $\therefore B(4, 6)$

(ii) Shaded area =  $\int_1^4 3\sqrt{x} dx - \int_1^4 (x+2) dx$   

$$= \left[ 2x^{\frac{3}{2}} \right]_1^4 - \left[ \frac{x^2}{2} + 2x \right]_1^4 = 14 - \frac{27}{2} = \frac{1}{2} \text{ units}^2$$

65. (i)  $\frac{dy}{dx} = -12(3x+4)^{-\frac{3}{2}}$   
 At  $x = 0$ ,  $\frac{dy}{dx} = -\frac{3}{2}$ ,  $\Rightarrow$  grad. of normal =  $\frac{2}{3}$   
 $\therefore$  Equation of  $AB$ :  $y = \frac{2}{3}x + 4$   
 At  $x = 4$ ,  $y = \frac{2}{3}(4) + 4 = \frac{20}{3}$ ,  $\therefore B(4, \frac{20}{3})$

(ii) Total area  $(P+Q) = \frac{1}{2}(4)(4 + \frac{20}{3}) = \frac{64}{3} \text{ units}^2$

Area of  $P = \int_0^4 \frac{8}{\sqrt{3x+4}} dx$   

$$= \left[ \frac{16}{3} \sqrt{3x+4} \right]_0^4 = \frac{32}{3} \text{ units}^2$$

Area of  $Q = \frac{64}{3} - \frac{32}{3} = \frac{32}{3} \text{ units}^2$

66.  $f(x) = \int (5 - 2x^2) dx = 5x - \frac{2x^3}{3} + K$

Subst.  $(3, 5)$  gives,  $K = 8$

$\therefore f(x) = 5x - \frac{2}{3}x^3 + 8$

67. (i) Volume =  $\pi \int_1^2 \left(\frac{4}{2x-1}\right)^2 dx$   

$$= 16\pi \int_1^2 (2x-1)^{-2} dx$$



(ii) Grad. of tangent to curve,  $\frac{dy}{dx} = \frac{-8}{(2x-1)^2}$

Grad. of line, normal to curve =  $\frac{1}{2}$

$\Rightarrow \frac{-8}{(2x-1)^2} \times \frac{1}{2} = -1 \Rightarrow (2x-1)^2 = 4$

$\Rightarrow 2x-1 = \pm 2 \Rightarrow x = \frac{3}{2}$  or  $x = -\frac{1}{2}$

at  $x = \frac{3}{2}$ ,  $y = \frac{4}{2(\frac{3}{2}-1)} = 2$ ,

at  $x = -\frac{1}{2}$ ,  $y = \frac{4}{2(-\frac{1}{2}-1)} = -2$

Subst.  $(\frac{3}{2}, 2)$  and  $(-\frac{1}{2}, -2)$  into line, normal to the curve, gives,  $c = \frac{5}{2}$  or  $-\frac{7}{2}$

68.  $y = \int (2x+1)^{\frac{1}{2}} dx = \frac{(2x+1)^{\frac{3}{2}}}{\frac{3}{2}} + K$

Subst.  $P(4, 7)$  gives,  $K = -2$

$\therefore$  equation of curve:  $\frac{(2x+1)^{\frac{3}{2}}}{3} - 2$

69. (i)  $\frac{dy}{dx} = 6 - 6x$ , At  $x = 2$ ,  $\frac{dy}{dx} = -6$

$\therefore$  Equation of AC:  $y = -6x + 21$

Subst.  $y = 0$ , into AC gives,  $x = \frac{7}{2}$

$\therefore$  x-coordinate of C =  $\frac{7}{2}$

(ii) Area of  $\Delta$  under AC =  $\frac{1}{2} \times \frac{3}{2} \times 9 = \frac{27}{4}$  units<sup>2</sup>

Area under curve AB =  $\int_2^3 (9 + 6x - 3x^2) dx$

=  $[9x + 3x^2 - x^3]_2^3 = 5$  units<sup>2</sup>

$\therefore$  Shaded area =  $\frac{27}{4} - 5 = \frac{7}{4}$  units<sup>2</sup>

70. (i)  $\frac{dy}{dx} = 2(1+4x)^{-\frac{1}{2}}$ , At  $P(6, 5)$ ,  $\frac{dy}{dx} = \frac{2}{5}$

Gradient of PQ =  $-\frac{5}{2}$

now,  $(\frac{2}{5})(-\frac{5}{2}) = -1$ ,  $\therefore$  PQ is a normal.

(ii) Volume for curve =  $\pi \int_0^6 \left( (1+4x)^{\frac{1}{2}} \right)^2 dx$

=  $\pi [x + 2x^2]_0^6 = 78\pi$

Volume for line PQ =  $\frac{1}{3} \pi (5)^2 (2) = \frac{50}{3} \pi$

$\therefore$  Total volume =  $78\pi + \frac{50}{3} \pi = \frac{284}{3} \pi$  units<sup>3</sup>

71. (i)  $\frac{dy}{dx} = -2x(9-2x^2)^{-\frac{1}{2}}$

At  $x = 2$ ,  $\frac{dy}{dx} = -4$ ,  $\Rightarrow$  grad of normal =  $\frac{1}{4}$

$\therefore$  Equation of AP:  $4y = x + 2$

Subst.  $y = 0$ , into AP gives,  $A(-2, 0)$

Subst.  $x = 0$ , into AP gives,  $B(0, \frac{1}{2})$

Mid-point of AP =  $(\frac{-2+0}{2}, \frac{0+\frac{1}{2}}{2}) = (0, \frac{1}{4})$

(ii)  $y = \sqrt{9-2x^2} \Rightarrow x^2 = \frac{9}{2} - \frac{y^2}{2}$

For y-intercept, put  $x = 0$ ,  $\therefore y = \sqrt{9-0} = 3$

Volume =  $\pi \int_1^3 \left( \frac{9}{2} - \frac{y^2}{2} \right) dy$

=  $\pi \left[ \frac{9}{2}y - \frac{y^3}{6} \right]_1^3 = 4\frac{2}{3} \pi$  units<sup>3</sup>

72. (i)  $f'(x) = 2 - 2(x+1)^{-3}$ ,  $f''(x) = 6(x+1)^{-4}$

at  $x = 0$ ,  $f'(0) = 2 - 2 = 0$ ,

$\therefore$   $f(x)$  has a stationary point at  $x = 0$

$f''(0) = 6(0+1)^{-4} = 6 > 0$ ,  $\therefore$  minimum.

(ii)  $|AB| = \sqrt{(1+\frac{1}{2})^2 + (\frac{9}{4}-3)^2} = \frac{\sqrt{45}}{4}$  units

(iii) Area under curve AB =  $\int_{-\frac{1}{2}}^1 (2x + (x+1)^{-2}) dx$

=  $[x^2 - (x+1)^{-1}]_{-\frac{1}{2}}^1 = \frac{1}{2} + \frac{7}{4} = \frac{9}{4}$  units<sup>2</sup>

Area of trapezium under AB =  $\frac{1}{2} (\frac{3}{2})(3 + \frac{9}{4})$   
=  $\frac{63}{16}$  units<sup>2</sup>

$\therefore$  Shaded area =  $\frac{63}{16} - \frac{9}{4} = \frac{27}{16}$  units<sup>2</sup>

$$\begin{aligned}
 73. \text{ Volume} &= \pi \int_1^2 \left( \frac{12}{y^2} - 2 \right)^2 dy \\
 &= \pi \int_1^2 (144y^{-4} - 48y^{-2} + 4) dy \\
 &= \pi \left[ -\frac{48}{y^3} + \frac{48}{y} + 4y \right]_1^2 = 22\pi \text{ units}^3
 \end{aligned}$$

$$\begin{aligned}
 74. \int dy &= \int 8(5-2x)^{-2} dx \Rightarrow y = 4(5-2x)^{-1} + K \\
 \text{Subst. (2, 7) gives, } K &= 3 \\
 \therefore \text{ equation of curve: } y &= \frac{4}{(5-2x)} + 3
 \end{aligned}$$

$$\begin{aligned}
 75. \text{ Volume} &= \pi \int_0^2 \left( (x^3+1)^{\frac{1}{2}} \right)^2 dx \\
 &= \pi \int_0^2 (x^3+1) dx \\
 &= \pi \left[ \frac{x^4}{4} + x \right]_0^2 = 6\pi \text{ units}^3
 \end{aligned}$$

$$\begin{aligned}
 76. \text{ (i) At } P(1, 9), \frac{dy}{dx} &= 6+k \\
 \therefore 6+k &= 2 \Rightarrow k = -4
 \end{aligned}$$

$$\begin{aligned}
 \text{(ii) } y &= \int (6x^2 - 4x^{-3}) dx = 2x^3 + \frac{2}{x^2} + K \\
 \text{Subst. } P(1, 9) \text{ gives, } K &= 5 \\
 \therefore \text{ equation of curve: } y &= 2x^3 + \frac{2}{x^2} + 5
 \end{aligned}$$

$$77. \text{ (i) Subst. } y=0, \text{ gives, } x = \frac{1}{2}, \therefore A\left(\frac{1}{2}, 0\right)$$

$$\begin{aligned}
 \text{(ii) Area of the shaded region} \\
 &= \int_0^{\frac{1}{2}} (1-2x)^{\frac{1}{2}} dx - \int_0^{\frac{1}{2}} (2x-1)^2 dx \\
 &= \left[ -\frac{(1-2x)^{\frac{3}{2}}}{3} \right]_0^{\frac{1}{2}} - \left[ \frac{(2x-1)^3}{6} \right]_0^{\frac{1}{2}} \\
 &= \frac{1}{3} - \frac{1}{6} = \frac{1}{6} \text{ units}^2
 \end{aligned}$$

$$\begin{aligned}
 78. \int dy &= 8 \int (4x+1)^{-\frac{1}{2}} dx \Rightarrow y = 4\sqrt{4x+1} + K \\
 \text{Subst. (2, 5) gives, } K &= -7 \\
 \therefore \text{ equation of the curve is: } y &= 4\sqrt{4x+1} - 7
 \end{aligned}$$

$$\begin{aligned}
 79. \text{ (i) } \frac{dy}{dx} &= -k(kx-3)^{-2} + k = 0 \\
 \Rightarrow \frac{-k}{(kx-3)^2} + k &= 0 \Rightarrow (kx-3)^2 = 1, \\
 \Rightarrow x &= \frac{2}{k} \text{ or } x = \frac{4}{k} \\
 \frac{d^2y}{dx^2} &= 2k^2(kx-3)^{-3}
 \end{aligned}$$

$$\text{At } x = \frac{2}{k}, \frac{d^2y}{dx^2} = -2k^2, \therefore \text{Maximum}$$

$$\text{At } x = \frac{4}{k}, \frac{d^2y}{dx^2} = 2k^2, \therefore \text{Minimum}$$

$$\begin{aligned}
 \text{(ii) Volume} &= \pi \int_0^2 \left[ (x-3)^{-1} + (x-3) \right]^2 dx \\
 &= \pi \int_0^2 \left[ (x-3)^{-2} + 2 + (x-3)^2 \right] dx \\
 &= \pi \left[ -(x-3)^{-1} + 2x + \frac{(x-3)^3}{3} \right]_0^2 \\
 &= \pi \left[ \left( \frac{14}{3} \right) - \left( -\frac{26}{3} \right) \right] = \frac{40}{3} \pi \text{ units}^3
 \end{aligned}$$